

AxCIS™ Series

AxCIS Contact Image Sensor User Manual

sensors | **cameras** | frame grabbers | processors | software | vision solutions



03-032-25022-12
www.teledynedalsa.com

CAMERA
LinkHS™

 **TELEDYNE**

Notice

©2023-2025 Teledyne Digital Imaging, Inc.

All information provided in this document is believed to be accurate and reliable. Teledyne DALSA assumes no liability for the use of the products described herein. Reproduction or transmission of this manual, in whole or in part, in any form or by any means, is prohibited without prior written permission from Teledyne DALSA. Teledyne DALSA reserves the right to modify the content of this document at any time and without notice.

AxCIS, Sopera and Xtium are trademarks of Teledyne Digital Imaging.

Camera Link HS is a registered trademark of the Association for Advancing Automation.

GenICam is a trademark of the European Machine Vision Association.

Microsoft, Windows and Visual Studio are registered trademarks of the Microsoft group of companies.

All other trademarks are the property of their respective owners.

Document Date: 2025-11-10

About Teledyne DALSA, a business unit of Teledyne Digital Imaging Inc.

Teledyne DALSA is a leader in the design, manufacture, and deployment of digital imaging components and solutions for machine vision. From image sensors, cameras, smart cameras, and frame grabbers to sophisticated vision software and intelligent vision systems, our products define the top end of performance in the world's most demanding digital imaging applications.

Teledyne DALSA is also part of Teledyne Vision Solutions which offers the world's most comprehensive, vertically integrated portfolio of industrial and scientific imaging technology. Aligned under one umbrella, Teledyne DALSA, e2v CMOS image sensors, FLIR IIS, Lumenera, Photometrics, Princeton Instruments, Judson Technologies, Acton Optics, and Adimec form an unrivalled collective of expertise across the spectrum with decades of experience and best-in-class solutions.

This document does not contain information whose export/transfer/disclosure is restricted by the Canadian Export Control regulation.

Contents

AXCIS SERIES CAMERA FEATURES 2

- DESCRIPTION 2
 - CIS Optical Technology* 2
 - Models* 3
 - CIS Features* 3
 - Automatic Sensor Alignment* 3
 - Resolution* 4
 - Programmable Features* 5
 - Applications* 5
- PART NUMBERS AND SOFTWARE REQUIREMENTS 6
- PERFORMANCE SPECIFICATIONS 8
 - Industry Standard Reliability Qualifications* 10
- SUPPORTED INDUSTRY COMMUNICATIONS STANDARDS 10
 - SFP+ Modules* 11
 - Image Data Cables and Transceivers* 11
- SAFETY INSTRUCTIONS AND PRECAUTIONS 12
- MECHANICAL DRAWINGS 13
- AXCIS INSTALLATION AND SETUP FLOWCHART 25
- AXCIS MOUNTING AND INSTALLATION 26
 - Irregular or Non-Linear Target Surface* 27
- INSTALL & CONFIGURE FRAME GRABBER AND SOFTWARE 28
 - Cable Connections to Frame Grabber* 29
 - Selecting the Required Firmware Configuration* 30
- SETTING UP FOR IMAGING 32
 - Camera I / O Connectors* 32
 - Powering the Module* 33
 - Power and GPIO Connections* 34
 - Using Sopera CamExpert* 37
 - Establishing Module Communications* 39
 - Establishing Data Integrity* 42
 - Scan Direction* 43

CAMERA FEATURES 45

- PIXEL FORMAT 45
 - Sensor Saturation* 47
- MONOCHROME MODULE SPECIFIC FEATURES 48
 - Dual Exposure Mode (HDR)* 48
- COLOR MODULE SPECIFIC FEATURES 50
 - Exposure Times* 50
 - Output Formats* 50
 - Row Gains* 51
 - Color Transformation Matrices* 52
 - Automatic White Balancing* 53
 - Blue / Red Crosstalk Correction* 54
- SYNCHRONIZING TO OBJECT MOTION 56
 - Acquiring Images: Triggering the Camera* 56
- ESTABLISHING THE OPTIMAL RESPONSE 61
 - Image Response Uniformity & Flat Field Calibration* 61
 - Saving & Loading a PRNU Set Only* 62
 - Flat Field Calibration Regions of Interest* 62
- MAINTAINING IMAGE ALIGNMENT 63
 - Adjusting the Encoder (EXSYNC) Input* 63

<i>Changing Scan Direction</i>	65
<i>Angle Correction: Imaging when not Perpendicular to the Object Surface</i>	65
<i>Imaging with Non-Square Object Pixels</i>	66
USING AREA OF INTEREST (AOIS).....	67
<i>Reduce Image Data & Enhance Performance</i>	67
<i>Rules for Setting Areas of Interest</i>	68
<i>Steps to Setup Area of Interest for Each Module Section</i>	69
ADJUSTING RESPONSIVITY AND CONTRAST ENHANCEMENT.....	70
<i>Black Level</i>	70
<i>Adjusting Individual Pixels</i>	71
RESPONSE LEVELING.....	72
OPTIONAL LED ARRAY CONTROL.....	73
CUSTOMIZED LINEARITY RESPONSE (LUT).....	74
<i>How to Generate a LUT with CamExpert</i>	74
GAMMA CORRECTION FACTOR.....	77
SAVING & RESTORING CAMERA SETUP CONFIGURATIONS.....	78
<i>Active Settings for Current Operation</i>	79
<i>User Setting</i>	79
<i>Factory Settings</i>	79
<i>Default Setting</i>	79
APPENDIX A: GENICAM COMMANDS	80
CAMERA INFORMATION CATEGORY.....	81
<i>Camera Information Feature Descriptions</i>	81
<i>Built-In Self-Test Codes (BIST)</i>	82
<i>Power-Up Configuration Selection Dialog</i>	83
CAMERA CONTROL CATEGORY.....	84
<i>Camera Control Feature Descriptions</i>	85
DIGITAL IO CONTROL CATEGORY.....	88
<i>Digital IO Control Feature Descriptions</i>	88
FLAT FIELD CATEGORY.....	90
<i>Flat Field Control Feature Description</i>	90
IMAGE FORMAT CATEGORY.....	92
<i>Image Format Feature Description</i>	92
TRANSPORT LAYER CATEGORY.....	94
<i>Transport Layer Feature Descriptions</i>	94
ACQUISITION AND TRANSFER CONTROL CATEGORY.....	96
<i>Acquisition and Transfer Control Feature Descriptions</i>	96
<i>Features That Cannot Be Changed During a Transfer</i>	96
FILE ACCESS CONTROL CATEGORY.....	97
<i>File Access Control Feature Descriptions</i>	97
<i>File Access via the CamExpert Tool</i>	99
<i>CLHS File Transfer Protocol</i>	100
<i>Download a List of Camera Parameters</i>	102
APPENDIX B: TROUBLESHOOTING GUIDE	103
DIAGNOSTIC TOOLS.....	103
RESOLVING CAMERA ISSUES.....	106
<i>Communications</i>	106
<i>Image Quality Issues</i>	107
<i>Power Supply Issues</i>	109
DECLARATIONS OF CONFORMITY	110
<i>FCC Statement of Conformance for Class A</i>	110
<i>EU and UKCA Declaration of Conformity</i>	110

DOCUMENT REVISION HISTORY	111
CONTACT INFORMATION	112
SALES INFORMATION	112
TECHNICAL SUPPORT	112

AxCIS Series Camera Features

Description

This document details the camera features and operation.

Teledyne DALSA introduces a breakthrough CMOS Contact Image Sensor (CIS) format camera with unprecedented speed, responsivity and low noise.

Over time, Teledyne DALSA will release the complete range of CIS cameras from less than 300 mm to 1500 mm. The name of this product family is AxCIS, with offerings of 400, 600, 700, 800 and 1500 mm scan widths at 300, 450, 600 or 900 dpi resolution (selectable) with optional integrated white LED illumination.

Cameras longer than 400 mm incorporate multiple modules (imaging sections) each with a separate interface to the host frame grabber.

The AxCIS incorporates Teledyne DALSA's latest CMOS sensor technology in a staggered arrangement that ensures 100% image coverage without interpolation (as with butted sensors), and self-calibration capabilities to ensure image uniformity and alignment.

To establish image alignment, each module appropriately delays the image data from each sensor. Factory calibration is performed using a scan direction pixel size of 84, 56, 42 or 28 μm (depending on selected dpi) with the module optical axis perpendicular to the object surface.

These cameras have a maximum line rate of 120 kHz with up to 900 dpi resolution for any length of module.

The camera uses the Camera Link HS™ interface—the industry standard for a very high-speed fiber optic camera interface with long transmission distances and cable flexing requirements.

Teledyne DALSA's AxCIS cameras and compatible frame grabbers combine to offer a complete solution for the next generation of automatic optical inspection systems.

These cameras are recommended when there is restricted space available to locate the imaging system. Teledyne DALSA's AxCIS cameras are well suited for detecting defects at high speeds over a large field of view where the 'telocentric like' properties of the Selfoc Lens Array (SLA) are desirable for limited measurement purposes and consistent defect classification.

CIS Optical Technology

AxCIS combines a Selfoc Lens Array (SLA), a linear array of Teledyne DALSA CMOS sensors, image processing, power management and optional integrated LED illumination to provide a complete imaging solution. Industry refers to this configuration as Contact Image Sensor (CIS) technology.

CIS modules are used for applications that require short working distance and or have limited space for optical components. Not only does AxCIS provide these common CIS features, but also adds Teledyne DALSA's advanced calibration and line scan features to offer a compact solution that goes beyond current CIS products.

Models

Table 1: AxCIS Model Part Numbers

Model Type	AxCIS Part Number	Description
Monochrome	AX-FM-04B12H-00	400 mm field of view selectable dpi, maximum line rate of 120 kHz, monochrome output, Camera Link HS LC fiber optic connectors.
	AX-FM-07B12H-00	700 mm field of view, selectable dpi, maximum line rate of 120 kHz, monochrome output, Camera Link HS LC fiber optic connectors.
	AX-FM-08B12H-00	800 mm field of view, selectable dpi, maximum line rate of 120 kHz, monochrome output, Camera Link HS LC fiber optic connectors.
	AX-FM-15B12H-00	1500 mm field of view, selectable dpi, maximum line rate of 120 kHz, monochrome output, Camera Link HS LC fiber optic connectors. .
Color	AX-FC-04B06T-00	400 mm field of view, selectable dpi, maximum line rate of 60 kHz, color output, Camera Link HS LC fiber optic connectors.
	AX-FC-06B06T-00	600 mm field of view, selectable dpi, maximum line rate of 60 kHz, color output, Camera Link HS LC fiber optic connectors.
	AX-FC-08B06T-00	800 mm field of view, selectable dpi, maximum line rate of 60 kHz, color output, Camera Link HS LC fiber optic connectors.

CIS Features

- Staggered sensor arrangement ensuring no lost or interpolated pixels
- Selectable dpi: options include 300, 450, 600 or 900 dpi resolution
- Highly sensitive multiline CMOS sensors
- Up to 120 kHz line rates
- Low noise and high full well
- Bidirectionality
- Camera Link HS interface, X-Protocol, 10 Gbps, LC connectors
- Optional integrated white LED illumination
- Compact enclosure
- IP60 rating for sensor and optical cavity
- Single 24 V \pm 10% power supply

Automatic Sensor Alignment

Other CIS modules typically comprise a linear array of small sensors butted end to end to provide a large field of view. Due to the physical characteristics of the sensors, there are lost pixels at the butt joints which need to be interpolated with associated loss of image quality. To ensure 100% image coverage, the AxCIS modules use a staggered sensor approach where adjacent sensors fields of view overlap their neighbors preserving image quality.

Each sensor's physical location is accurately measured during the production calibration process where alignment parameters are sent and stored by the module for use in normal operation. The module automatically aligns each sensor's image data real time in x and y directions to form a continuous single, aligned image data. Overlap image data is removed.

Resolution

- Selectable dpi: options include 300, 450, 600 or 900 dpi resolution
- Multiple lengths feasible in 100 mm increments

Table 2: AxCIS Camera Resolutions

		1500 mm ¹		800 mm ²		700 mm ³		600 mm ⁴		400 mm	
Resolution	Pixel Size	Imaging Pixels	Pixels Output ⁵	Imaging Pixels	Pixels Output	Imaging Pixels	Pixels Output	Imaging Pixels	Pixels Output	Imaging Pixels	Pixels Output
300 dpi	84	17850	17856	9520	9536	8330	8336	7140	7168	4760	4768
450 dpi	56	26790	26832	14288	14304	12502	12512	10716	10752	7144	7152
600 dpi	42	35700	35712	19040	19072	16660	16672	14280	14336	9520	9536
900 dpi	28	53580	53664	28576	28608	25004	25024	21432	21440	14288	14304

1: 1500 mm image width is created using three 500 mm image buffers with a third of the pixel output in this table. AxCIS internally handles alignment of each 500 mm module so that only concatenation is required in frame grabber to output an aligned 1500 mm FOV image.
 2: 800 mm image width is created using two image buffers with half the pixel output in this table. AxCIS internally handles alignment of each 400 mm module so that only concatenation is required in frame grabber to output an aligned 800 mm FOV image.
 3: 700 mm image width is created using two image buffers with 4/7 and 3/7 the pixel output in this table. AxCIS internally handles alignment of each module so that only concatenation is required in frame grabber to output an aligned 700 mm FOV image.
 4: 600 mm image width is created using two image buffers with half the pixel output in this table. AxCIS internally handles alignment of each 300 mm module so that only concatenation is required in frame grabber to output an aligned 600 mm FOV image.
 5: The pixels output are rounded up to the next multiple of 32 (600 and 900 dpi) or 16 (300 and 450 dpi) to meet a CLHS requirement. Extra pixels will be black (0 DN).

Table 3: AxCIS Camera Padding Pixels (0 DN)

Resolution	1500 mm	800 mm	700 mm	600 mm	400 mm
300 dpi	5951-5952, 11903-11904, 17855-17856	4761-4768, 9529-9536	4761-4768, 8329-8336	3571-3584, 7155-7168	4761-4768
450 dpi	8931-8944, 17875-17888, 26819-26832	7145-7152, 14297-14304	7145-7152, 12505-12512	5359-5376, 10735-10752	7145-7152
600 dpi	11901-11904, 23805-23808, 35709-35712	9521-9536, 19057-19072	9521-9536	7141-7168, 14309-14336	9521-9536
900 dpi	17861-17888, 35749-35776, 53637-53664	14289-14304, 28593-28608	14289-14304	10717-10720, 21437-21440	14289-14304

Programmable Features

- Mono operates in single or dual row mode with independent exposure control useful for high dynamic range (HDR) applications
- Color operates with one exposure time for red and blue and a second exposure time for green
- Multiple areas of interest (AOIs) for data reduction
- Region of interest (ROI) for easy calibration of shading correction
- Flexible gain and offset controls
- Module angle correction
- Encoder input multiplier
- 8-bit and 12-bit operation
- Save & restore multiple user configurations
- Intensity control of optional LED arrays
- Test patterns and diagnostics

Applications

- Flat panel inspection
- Web and textile inspection
- Printed circuit board inspection
- 3D printer inspection
- High-throughput applications

Part Numbers and Software Requirements

The camera is available in the following configurations:

Table 4: Camera Models Comparison

Part Number	Maximum Resolution	Field of View	Max. Line Rates	Pixel Size	Control & Data
AX-FM-04B12H-00	900 dpi	400 mm	120 kHz single mono 60 kHz Dual Exposure mono	28x28 µm	Camera Link HS LC fiber optic
AX-FM-07B12H-00	900 dpi	700 mm	120 kHz single mono 60 kHz Dual Exposure mono	28x28 µm	Camera Link HS LC fiber optic
AX-FM-08B12H-00	900 dpi	800 mm	120 kHz single mono 60 kHz Dual Exposure mono	28x28 µm	Camera Link HS LC fiber optic
AX-FM-15B12H-00	900 dpi	1500 mm	120 kHz single mono 60 kHz Dual Exposure mono	28x28 µm	Camera Link HS LC fiber optic
AX-FC-04B06T-00	900 dpi	400 mm	60 kHz (600 dpi), 50 kHz (900 dpi) red/blue green color	28x28 µm	Camera Link HS LC fiber optic
AX-FC-06B06T-00	900 dpi	600 mm	60 kHz (600 dpi), 50 kHz (900 dpi) red/blue & green color	28x28 µm	Camera Link HS LC fiber optic
AX-FC-08B06T-00	900 dpi	800 mm	60 kHz (600 dpi), 50 kHz (900 dpi) red/blue & green color	28x28 µm	Camera Link HS LC fiber optic

Table 5: Part Numbering System

AX	- x	y	- rr	r	sss	- tt	- jj
Family	Interface	Spectrum	Width	Resolution	Line Rate	Variant	Light
AX – AxCIS	F – CLHS LC fiber	M – Mono C - Color	04-400 mm 07- 700 mm 08- 800 mm 15- 1500 mm	B- 300/450/600/900dpi	12H- 120/60 kHz mono/ HDR 06T – 50/60/100/120X3 KHz	00	W2- 2x white LEDs

Table 6: Frame Grabber

Teledyne DALSA Compatible Frame grabber	AxCIS Model
Xtium2-CLHS FX8 (OR-A8S0-FX840)	All models
Xtium2-CLHS FX8 LC (OR-A8S0-FX820)	

Table 7: Software

Software	Product Number / Version Number
Camera firmware	Embedded within camera
GenICam™ support (XML camera description file)	Embedded within camera
Sapera LT, including CamExpert GUI application and GenICam for Camera Link imaging driver	Latest version on the Teledyne DALSA Web site

Integrated lighting is available as an accessory. Each accessory is for a single LED light bar. Each AxCIS model can hold 2 LED light bars, therefore, 2 of each accessory can be ordered per AxCIS model.

LED lighting can be installed at the factory by using a -W2 (two LED light bars) in the part number. The general part number scheme for the various options is below.

Table:8 Accessories

Part Number	Description	Status
AC-LE-10004-xx	White LED light 400 mm	Ordered separately or in bundle.
AC-LE-10006-xx	White LED light 600 mm	Ordered separately or in bundle.
AC-LE-10007-xx	White LED light 700 mm	Ordered separately or in bundle.
AC-LE-10008-xx	White LED light 800 mm	Ordered separately or in bundle.
AC-LE-10015-xx	White LED light 1500 mm	Ordered separately or in bundle.
AC-CA-00424-xx-x	Power cable for CIS module	Ordered separately or in bundle.

The LED lighting has the following characteristics:

- Colour temperature: 5000 K
- CRI 80%
- Luminous Flux: ≥ 3000 lm for the 580 mm
- Luminous Efficacy: better than 193 lm/W @5000 K
- < 5% illumination variation from LED to LED position reflected from a Labertian diffusing flat surface positioned 24mm from the PCB surface

NOTE

Modules that are safety certified have the following symbol affixed:



Models with optional LED lighting are not considered UL safety certified by Intertek.

Performance Specifications

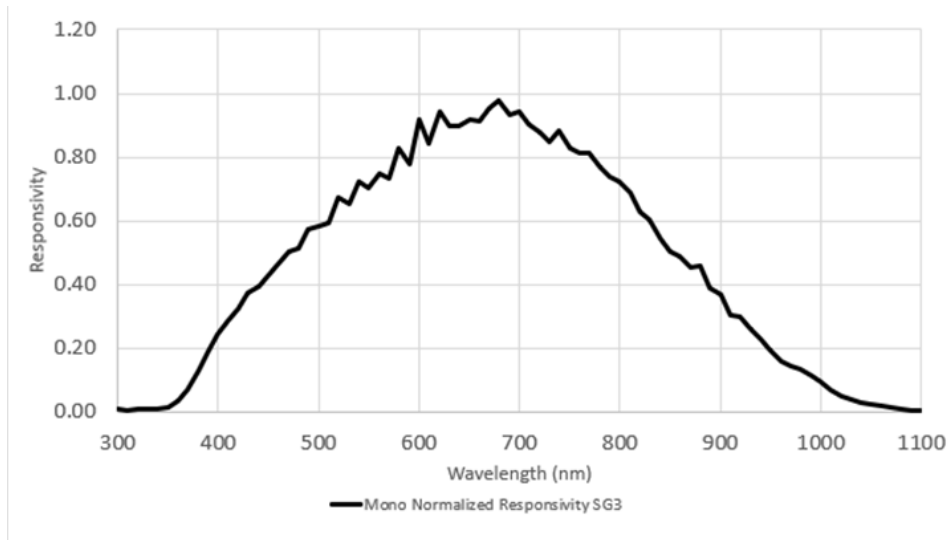

Figure 1: AxCIS Monochrome Responsivity Graph

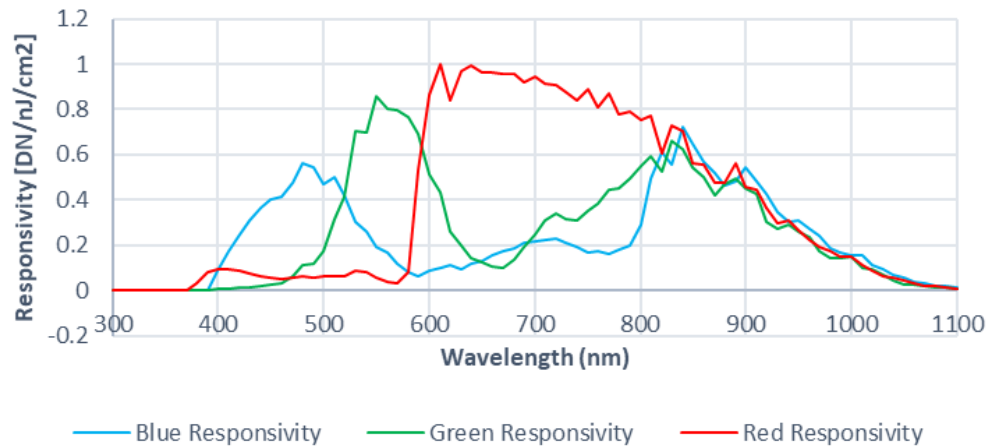

Figure 2: AxCIS Color Responsivity Graph

Table 9: AxCIS Specifications

Specification	Units	400, 700, 800 and 1500 mm (900 dpi)
Field of view (FOV)	mm	1500.125 mm – 1500 mm 800.125 mm – 800 mm 700.125 mm – 700 mm 600.125 mm – 600 mm 400.125 mm – 400 mm
Resolution	Pixels	53600 pixels – 1500 mm 28608 pixels – 800 mm 25024 pixels – 700 mm 21432 pixels – 600 mm 14304 pixels – 400 mm
Pixel Size	µm	28 µm (900 dpi)
Line Rate	kHz	120 kHz (single) 60 kHz x 2 (dual exposure) 50 kHz x 3 (color)
Minimum Line Rate	kHz	0 Hz – external trigger 300Hz – Internal trigger
Exposure Time	µsec	2.5 to 1310.7 µs
Metrology Measurement Error	µm @ 20C ambient @ 1 meter	< 65 µm
Measurement Error Over Temperature	µm per meter per Celsius	12 µm/m/C
Maximum Angle of Operation	+/- degrees	± 30 degrees
Mean Dynamic Range	dB	>70 dB
Mean Random Noise	DN rms	0.48 DN rms -8 bit 0.96 DN rms -12 bit
Integral Non-Linearity	% sat	< 1.5% sat
FPN	DN12 p-p	< 3 DN p-p
PRNU	% pk	< 1.5%
Full Well	e-	40 ke-
CTF over DoF	% @ 10 lp/mm (lines per mm)	> 40%
Weight (estimated)	Kg	10.2 kg (wo LED) – 1500 mm 12.5 kg (w LED) – 1500 mm 5.2 kg (wo LED) – 800 mm 6.3 kg (w LED) – 800 mm 5.2 kg (wo LED) – 700 mm 4.0 kg (wo LED) – 600 mm 4.9 kg (w LED) – 600 mm 2.7 kg (wo LED) – 400 mm 3.2 kg (w LED) – 400 mm
Power Consumption	W (@24v)	240 W (wo LED) – 1500 mm 320 W (w LED) – 1500 mm 100 W (wo LED) – 800 mm 167 W (w LED) – 800 mm 115 W (wo LED) – 700 mm 86 W (wo LED) – 600 mm 135 W (w LED) – 600 mm 65 W (wo LED) – 400 mm 86 W (w LED) – 400 mm
Flash Memory Size	GB	4

Dimensions (width x height x depth)		1541.8 x 100 x 75 mm – 1500 mm 841.8 x 100 x 75 mm – 800 mm 741.8 x 100 x 75 mm – 700 mm 641.8 x 100 x 75 mm – 600 mm 441.8 x 100 x 75 mm – 400 mm
Working Distance (from bottom of module)	mm	13.9 mm 14.13 mm (1500 mm model only)
Operating Temperature (ambient)	C	0 to 50°C
Operating Humidity		Non-condensing
Storage Temperature	C	-20C to 70C
Storage Humidity	%	15 to 85%
Dust Ingress Protection (optical cavity)	IP rating	IP60

All specifications measured at 25°C over a temperature range of ±10°C unless specifically stated.

Industry Standard Reliability Qualifications

Table 10: Industry Standard Reliability Qualifications

Reliability Test	Definition
Thermal Cycling Test	IPC-SM-785, IEC 60068-2-14
Temperature Humidity Cyclic Test	MIL883, IEC-60068-2-38
High Temperature Storage Test	JESD22-103A
Sequential Test	IEC 60068-2-6, IEC-60068-2-2, IEC-60068-2-78, IEC 60068-2-14
Vibration and Shock Test	IEC / DIN EN 60068-2-64 Part 2-64: Tests – Test Fh: Vibration, broadband random and guidance IEC / DIN EN 60068-2-27 Environmental testing – Part 2-27: Tests – Test Ea and guidance: Shock.

Supported Industry Communications Standards



The camera is GenICam compliant and implements a superset of the GenICam Standard Features Naming Convention specification V1.5.

This description takes the form of an XML device description file using the syntax defined by the GenApi module of the GenICam specification. The camera uses the GenICam Generic Control Protocol (GenCP V1.0) to communicate over the Camera Link HS command lane.

For more information see www.genicam.org.

AxCIS modules are Camera Link HS version 1.0 compliant. Camera Link HS is the next generation of high-performance communications standards. It is used where an industrial digital camera interfaces with a single or multiple frame grabbers and with data rates exceeding those supported by the LVDS based Camera Link standard.

For more information see www.automate.org.

SFP+ Modules

The AxCIS modules (imaging sections) come with a dual SFP+ (Small Form factor Pluggable) XCVR cage where one or two 10 Gbps XCVR modules can be added along with associated LC Fiber Optic cables as required to support image data bandwidth requirements.

NOTE

SFP+ XCVR cages are not included with the module and can be ordered separately from Teledyne DALSA or from another vendor who supplies compliant modules.

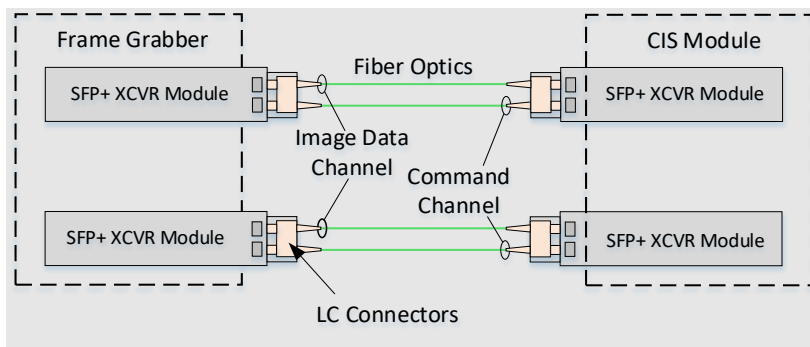

Figure 3: AxCIS CLHS Dual LC/SFP+ Connector Configuration.

The command channel is used by the frame grabber to send commands, configuration and programming data to the camera and to receive command responses, status and image data from the camera. Image data and command transmissions use CLHS X protocol (64b / 66b) at the default speed of 10 Gb/s per cable.

Image Data Cables and Transceivers

The fiber optic cables require LC connections and XCVR modules on both ends of the cable. LC is a small-form factor fiber optic connector that uses a 1.25 mm ferrule, half the size of a standard connector. These cables are in wide use in the telecommunications industry and available in many lengths.

The distance through which the data can be transmitted depends on the type of fiber optic used. Recommended fiber optic cables are types OM3 and OM4. OM4 is used for distances > 300 m, but also requires SFP+ transceiver module changes. Contact Teledyne DALSA Support for more information on recommended cables.

Table 11: LC Fiber Optic Cable Details

Category	Fiber Diameter	Mode	Max Distance
OM3	50 µm	Multimode	< 280 m
OM4	50 µm	Multimode	> 300 m

The following table is provided to support the specific fiber optic cabling needs of the user. The individual parts can be ordered from Teledyne DALSA or a third party.

Table 12: LC Fiber Optic Cable Parts

Part #	Manufacturer part#	Description
AC-CA-00419-00-R	SFP-10GSR-85 OM3LCSDX	Optical cable kit: 10m short boot fiber optic cable 2 XCVR 10G SFP+ modules

Safety Instructions and Precautions

Read these safety instructions and precautions before using the AxCIS.



Caution: Hot surface; do not touch. Product may reach temperatures which may cause burns. Wait one half hour after switching off before handling. To avoid burns wear protective gloves when handling the unit.



Caution: Risk of injury due to falling module. Product must be mounted securely to System Base before use.

- Confirm that the module's packaging is undamaged before opening it. If the packaging is damaged, please contact the related logistics personnel.
- Do not open the housing of the module. The warranty is voided if the housing is opened.
- During normal operation, maintain the module housing temperature in a range of 0 °C to +50 °C; when properly mounted, the module temperature is generally +20 °C above ambient room temperature. The module can measure its internal temperature. Use this feature to record the internal temperature of the module when it is mounted in your system and operating under the worst-case conditions. The module will stop outputting data if its internal temperature reaches +80 °C.
- Do not operate the module in the vicinity of strong electromagnetic fields. In addition, avoid electrostatic discharging, violent vibration and excess moisture.
- To clean the device, avoid electrostatic charging by using a dry, clean absorbent cotton cloth dampened with a small quantity of pure alcohol. Do not use methylated alcohol. To clean the surface of the camera housing, use a soft, dry cloth. To remove severe stains, use a soft cloth dampened with a small quantity of neutral detergent and then wipe dry. Do not use volatile solvents such as benzene and thinners, as they can damage the surface finish.
- Though this module supports hot plugging, it is recommended to power down and disconnect power to the module before adding or replacing system components.
- Ensure that all 12 pins of +24V and Power GND on the D-Sub connector are connected to the power supply before turning the camera on. Failure to do so could cause a burn. Minimum wire gauge is 22 AWG per pin. See the [26-pin High Density D-Sub Signal Details](#) section for pinout information.

NOTE

Product certifications can be found on Intertek's [ETL Listed Mark Directory](#); **models with optional LED lighting** (-W2 option) **are not considered UL safety certified.**

See the [Declarations of Conformity](#) section for FCC, EU and UKCA information.

The safety information in this section is available for download from the [AxCIS product page on the Teledyne website](#), in both English and French, as a separate document.t

Mechanical Drawings

3D stepfiles (.STP) are available for download from the Teledyne DALSA website: [AxCIS | Teledyne DALSA](#)

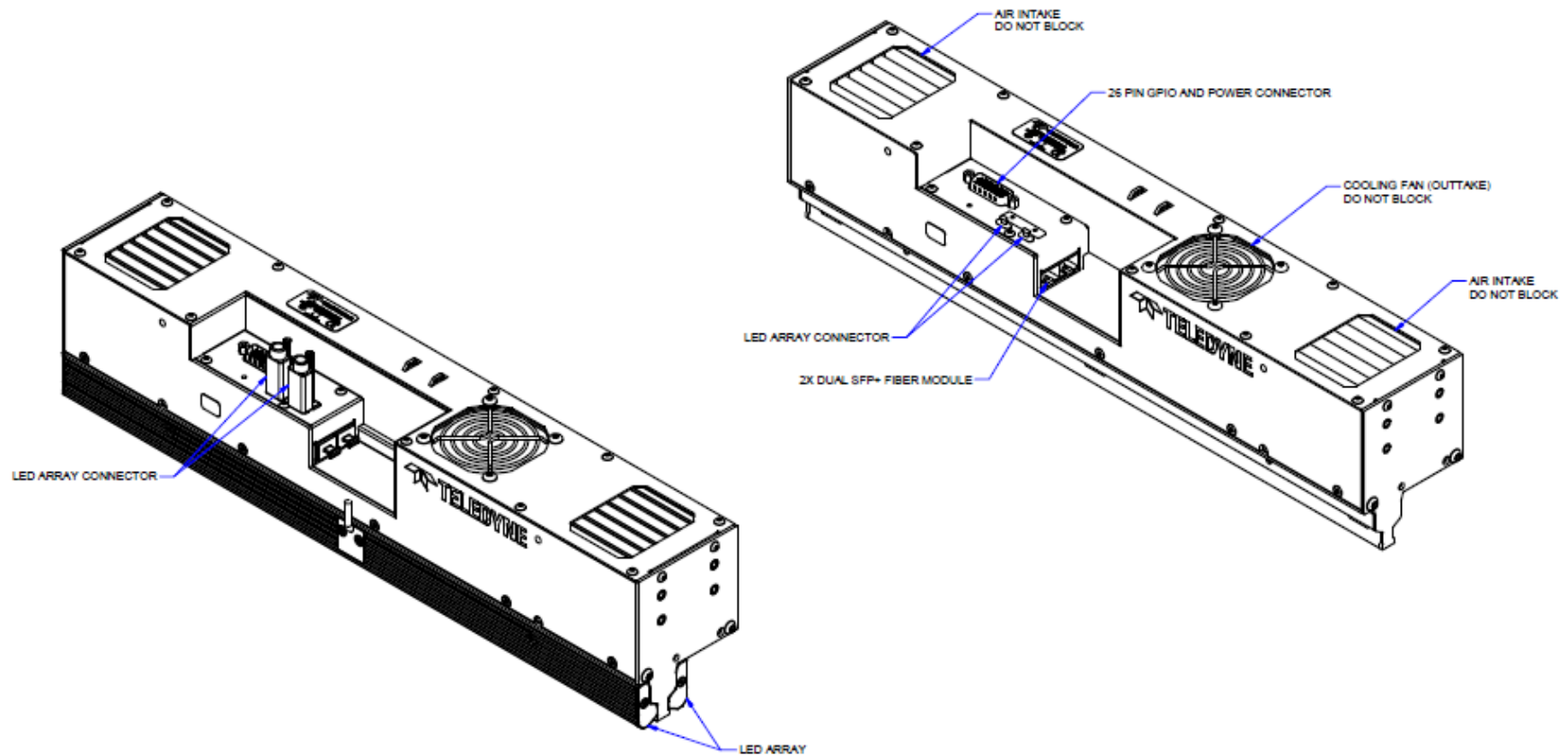

Figure 4: AX-FM-04B12A-00 & AX-FC-04B06T-00 400MM General Overview

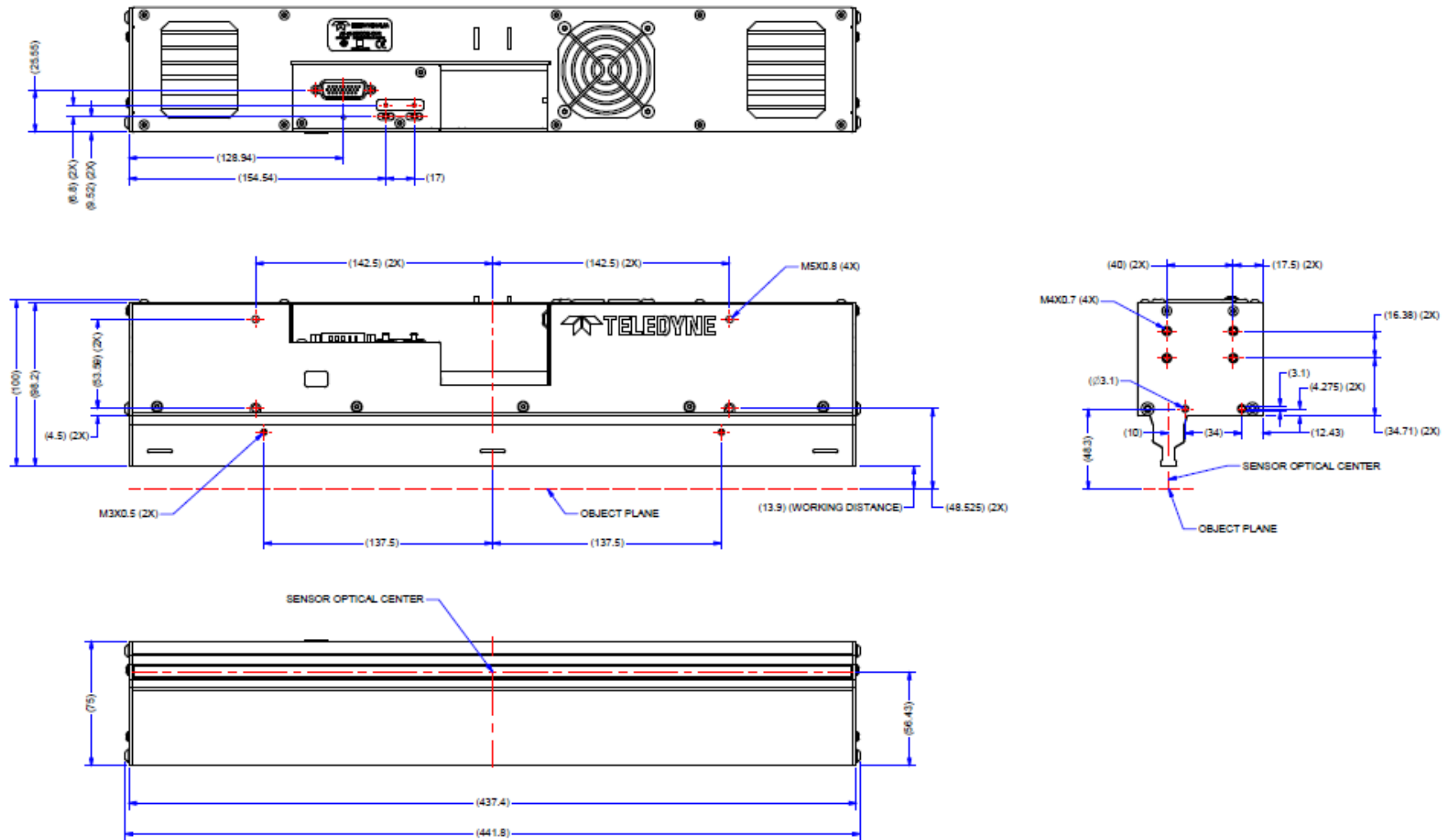

Figure 5: AX-FM-04B12A-00 & AX-FC-04B06T-00 400MM Mechanical Drawing (without optional LEDs)

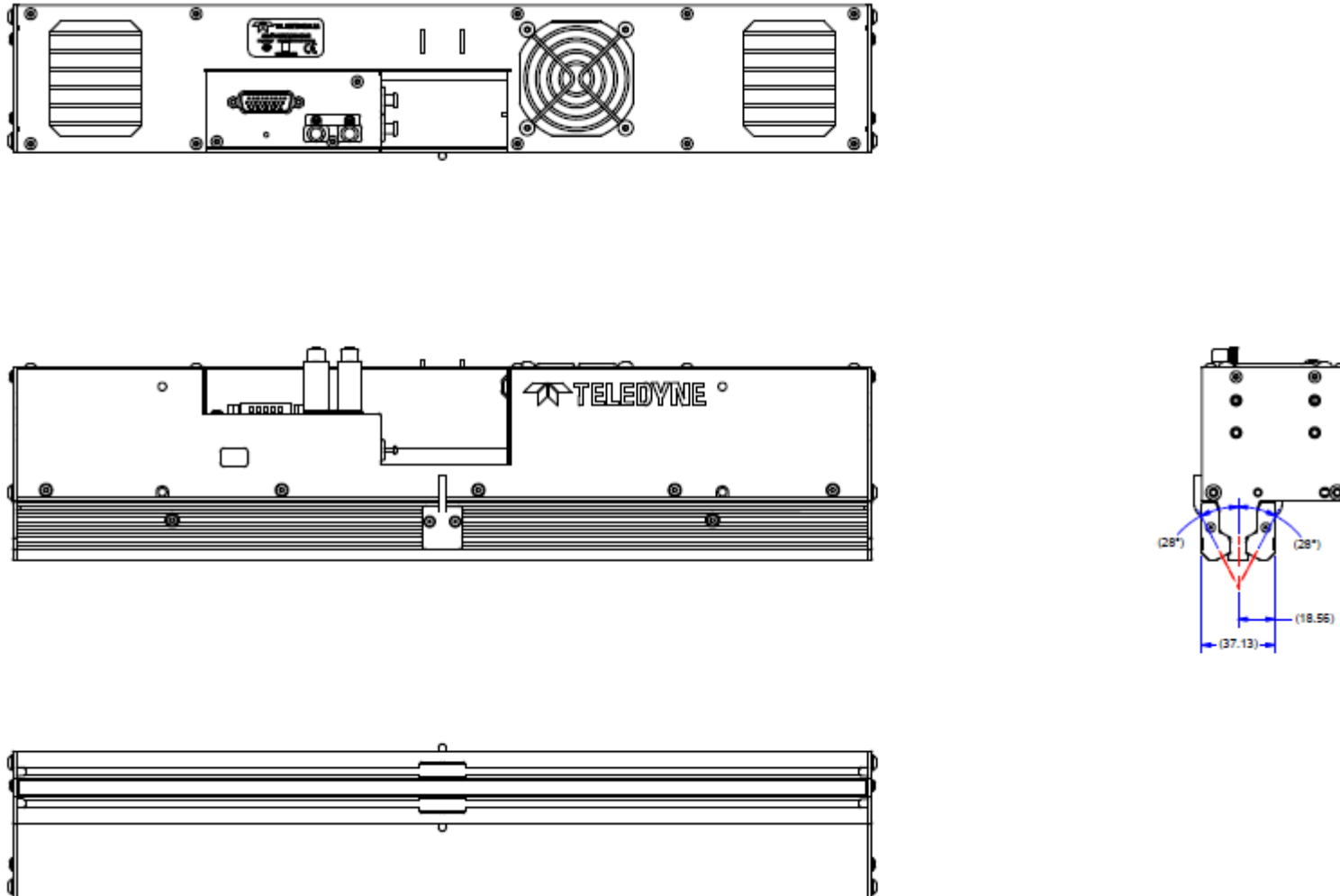

Figure 6: AX-FM-04B12A-00-W2 & AX-FC-04B06T-00-W2 400MM Mechanical Drawing (with optional LEDs)

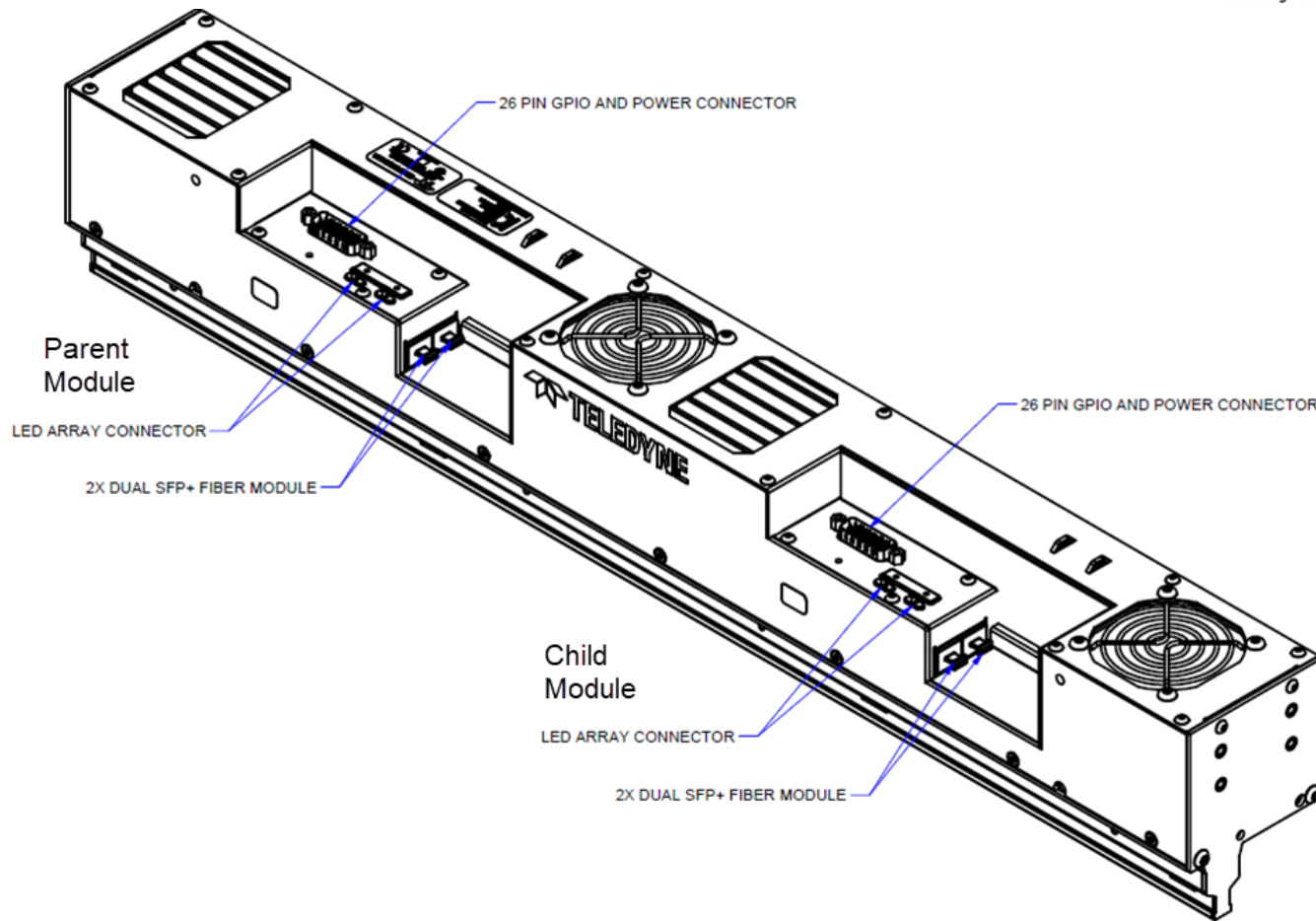

Figure 7: AX-FC-06B06T-00 600MM General Overview

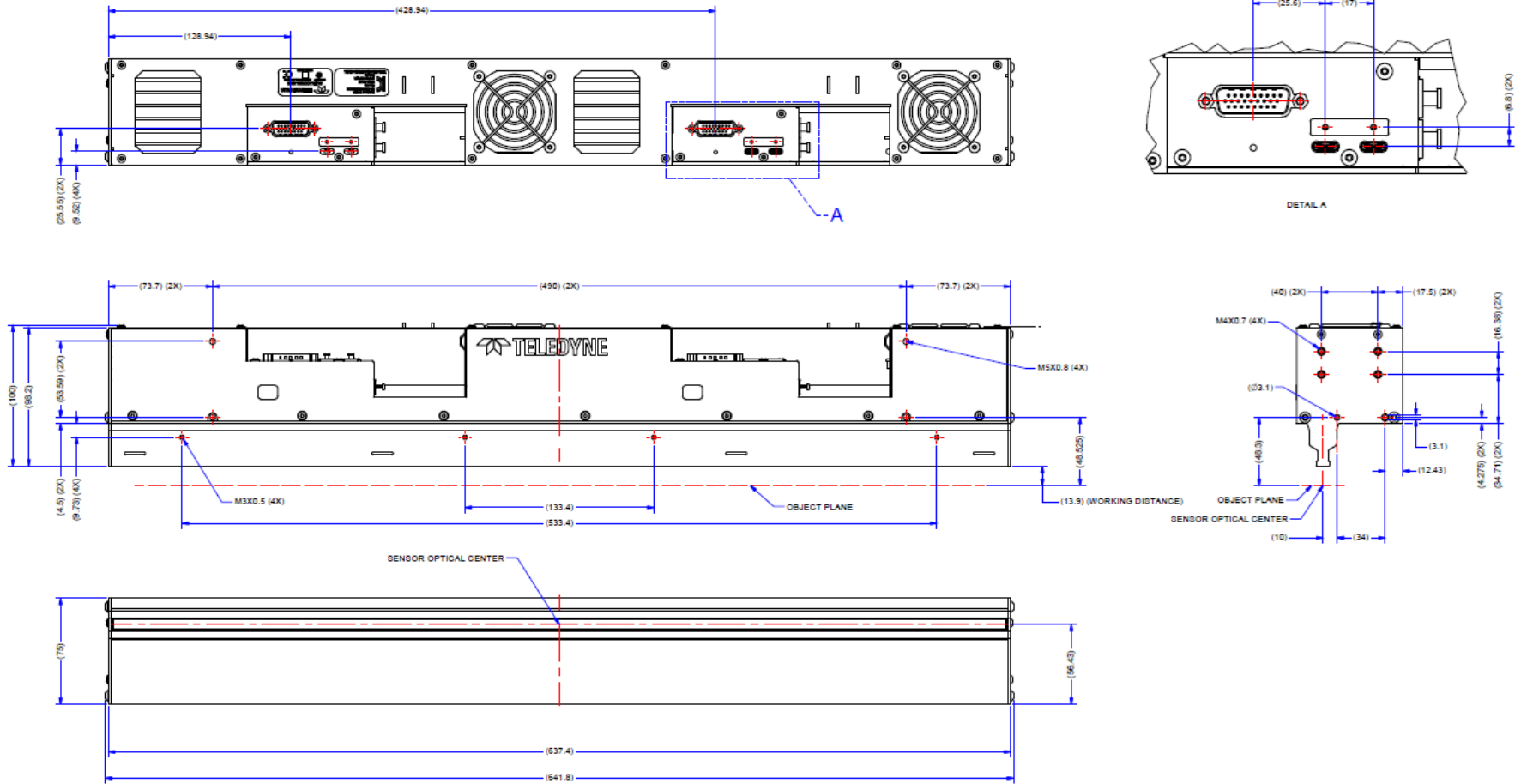

Figure 8: AX-FC-06B06T-00 600MM Mechanical Drawing (without optional LEDs)

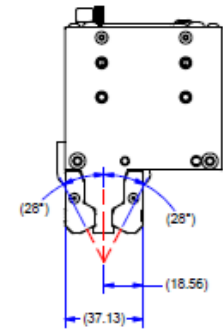
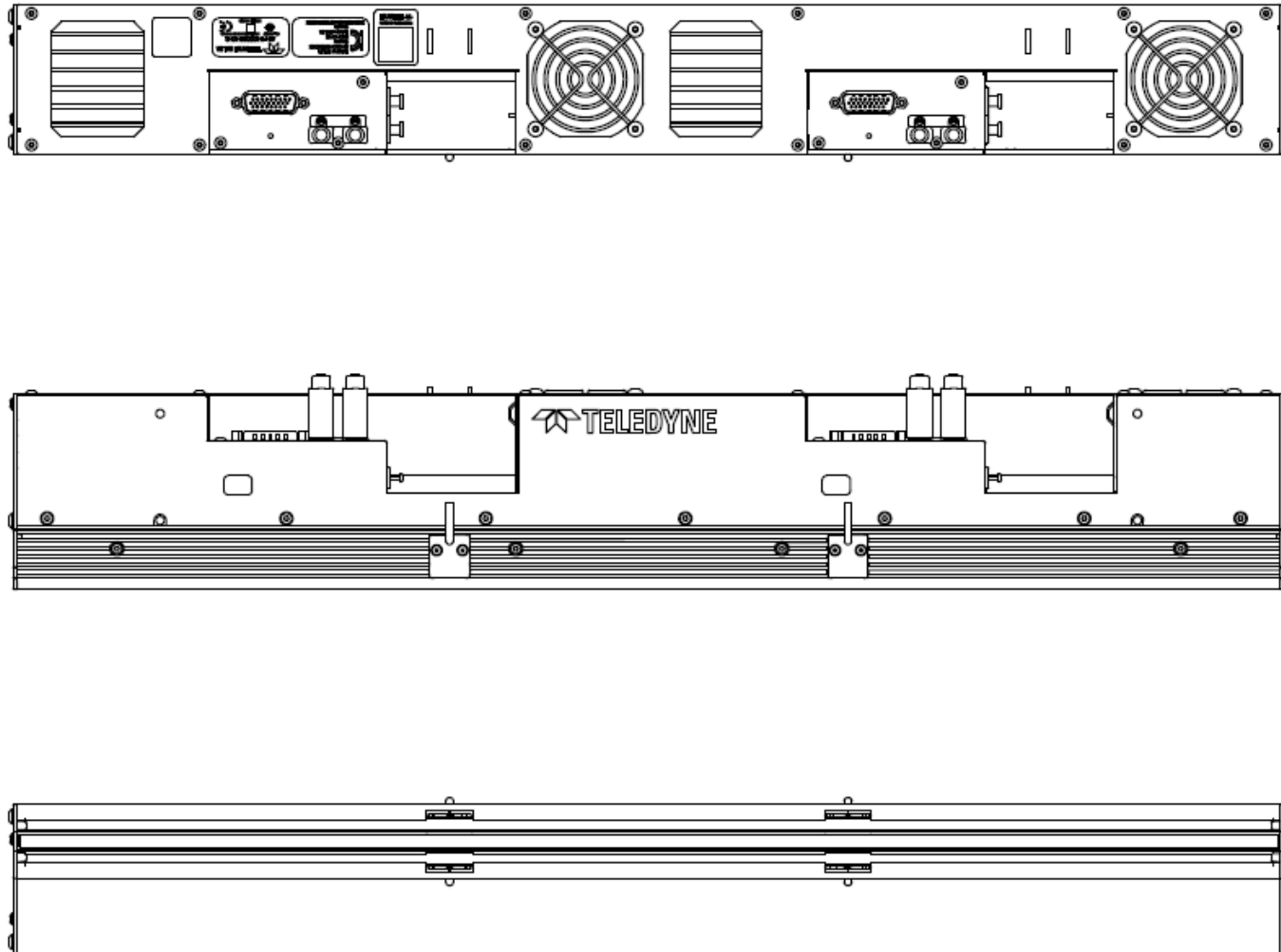

Figure 9: AX-FC-06B06T-00-W2 600MM Mechanical Drawing (with optional LEDs)

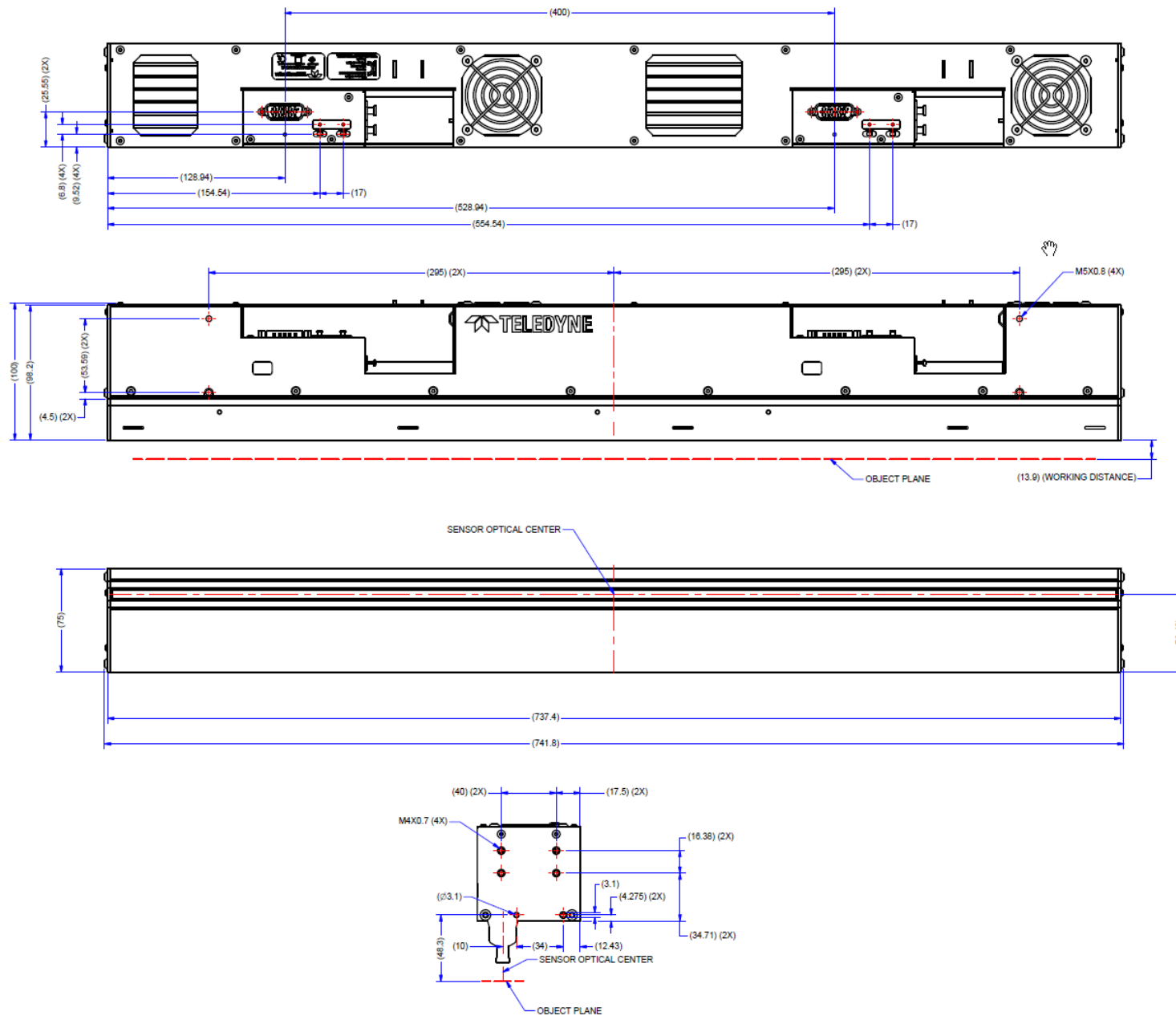

Figure 10: AX-FM-07B12H-00 700MM Mechanical Drawing

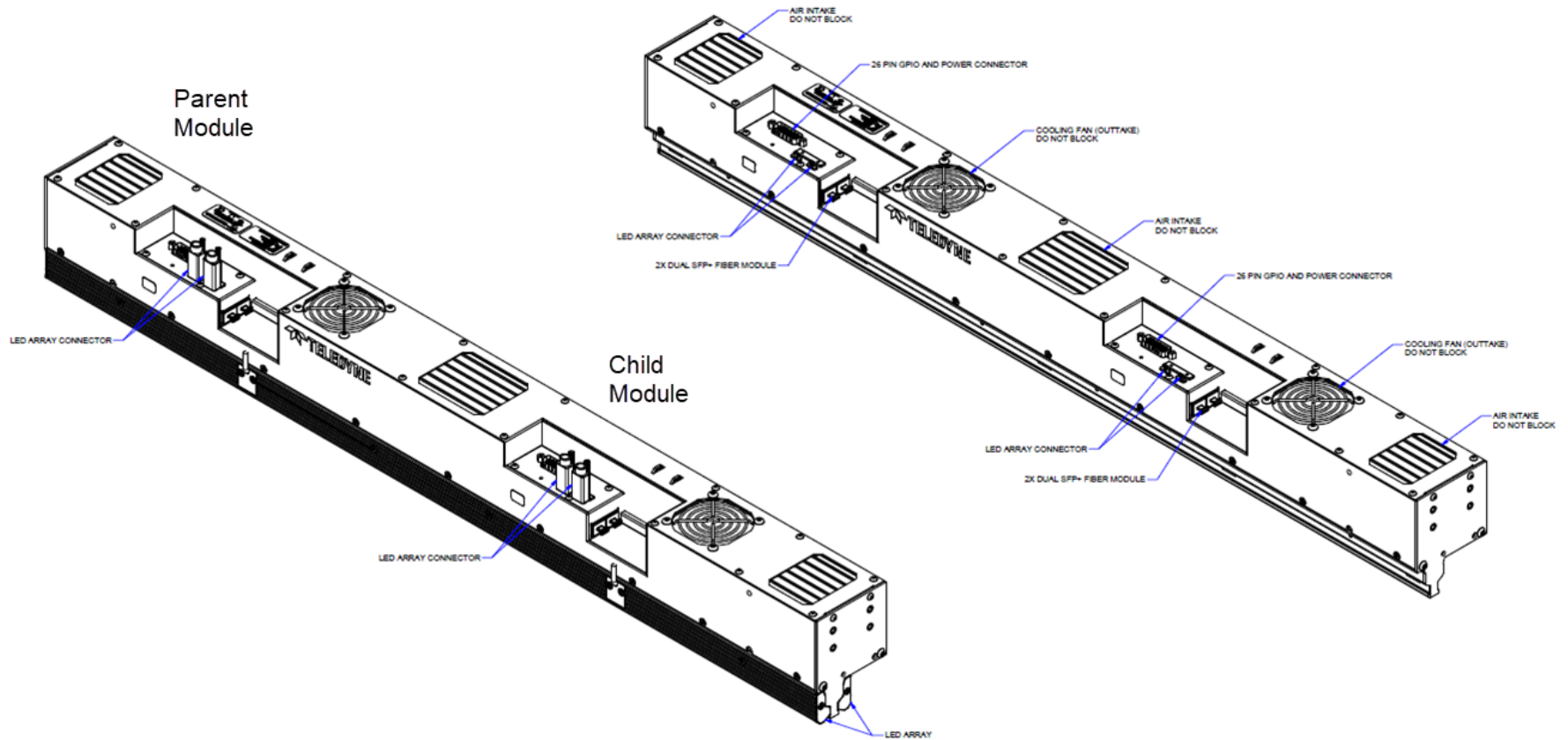

Figure 11: AX-FM-08A/B12H-00 800mm CIS Mechanical Drawing General Overview

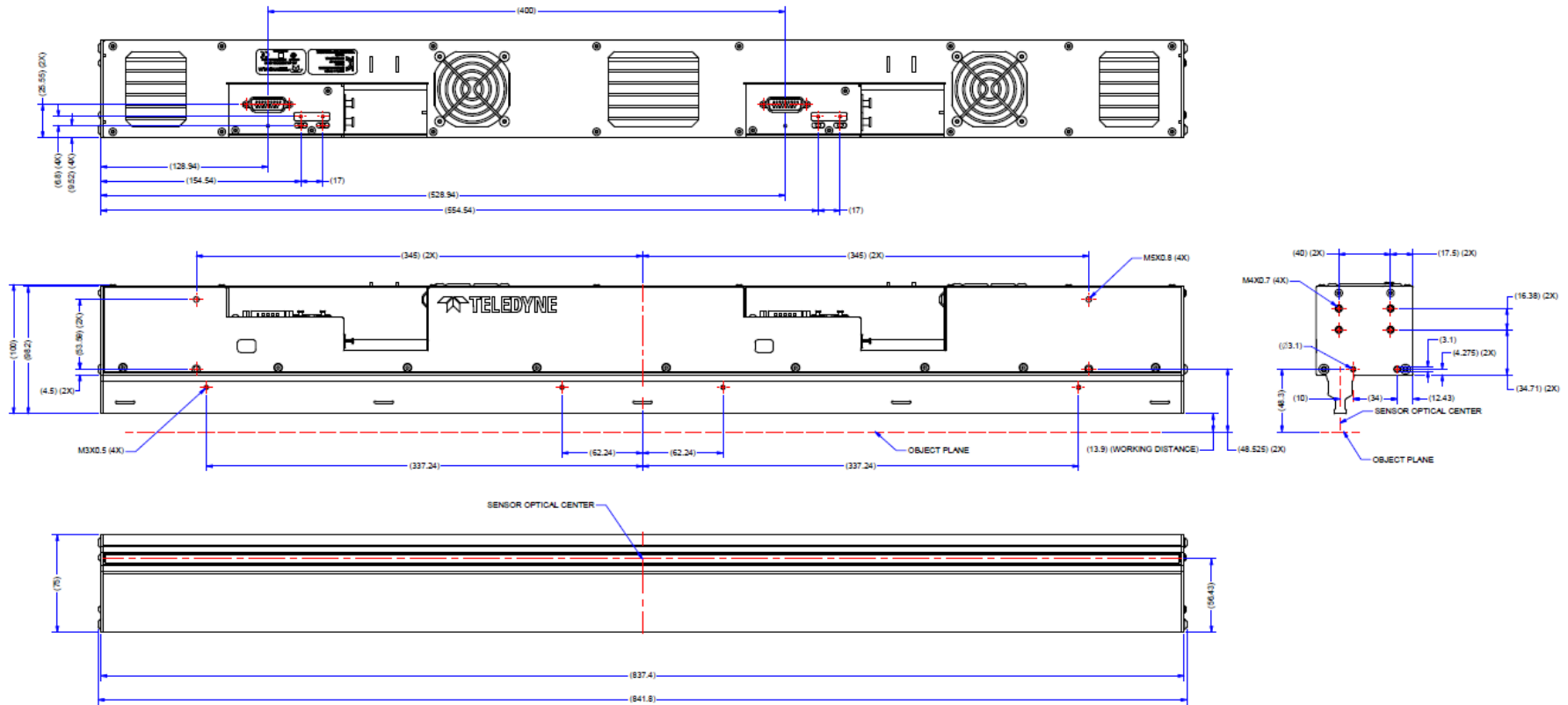

Figure 12: AX-FM-08A/B12H-00 800mm CIS Mechanical Drawing (without optional LEDs)

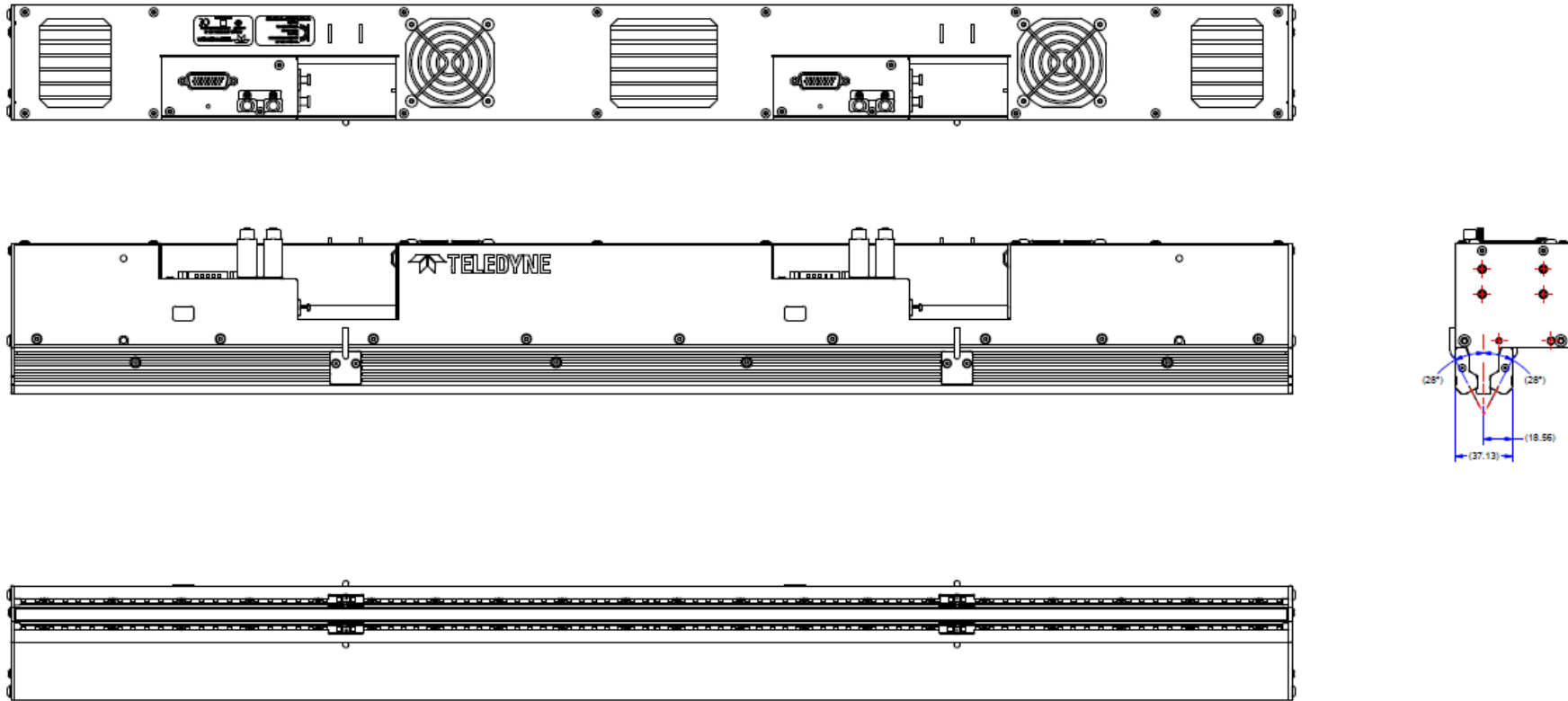

Figure 13: AX-FM-08A/B12H-00-W2 800mm CIS Mechanical Drawing (with optional LEDs)

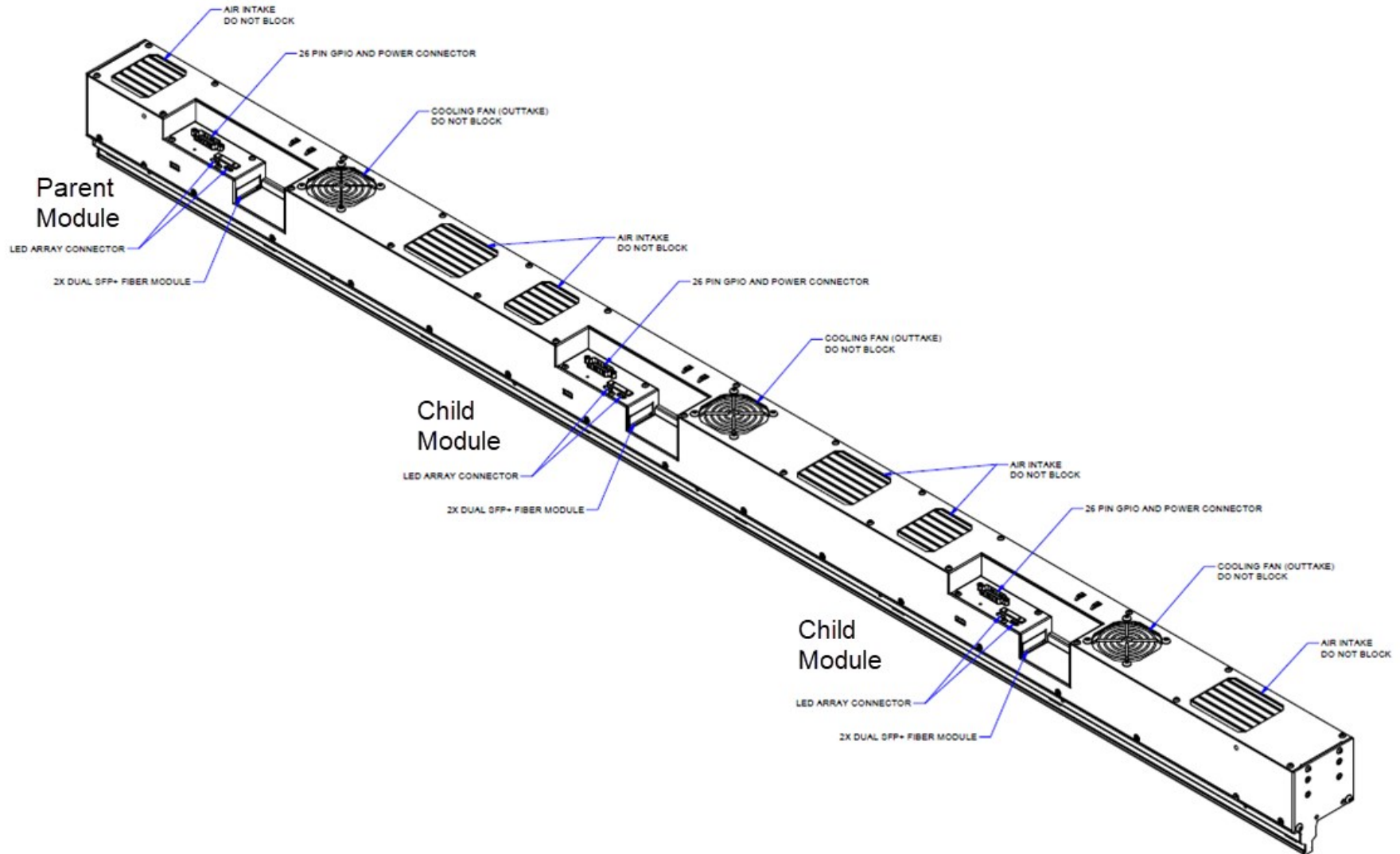

Figure 14: AX-FM-15B12H-00 1500mm CIS Mechanical Drawing General Overview

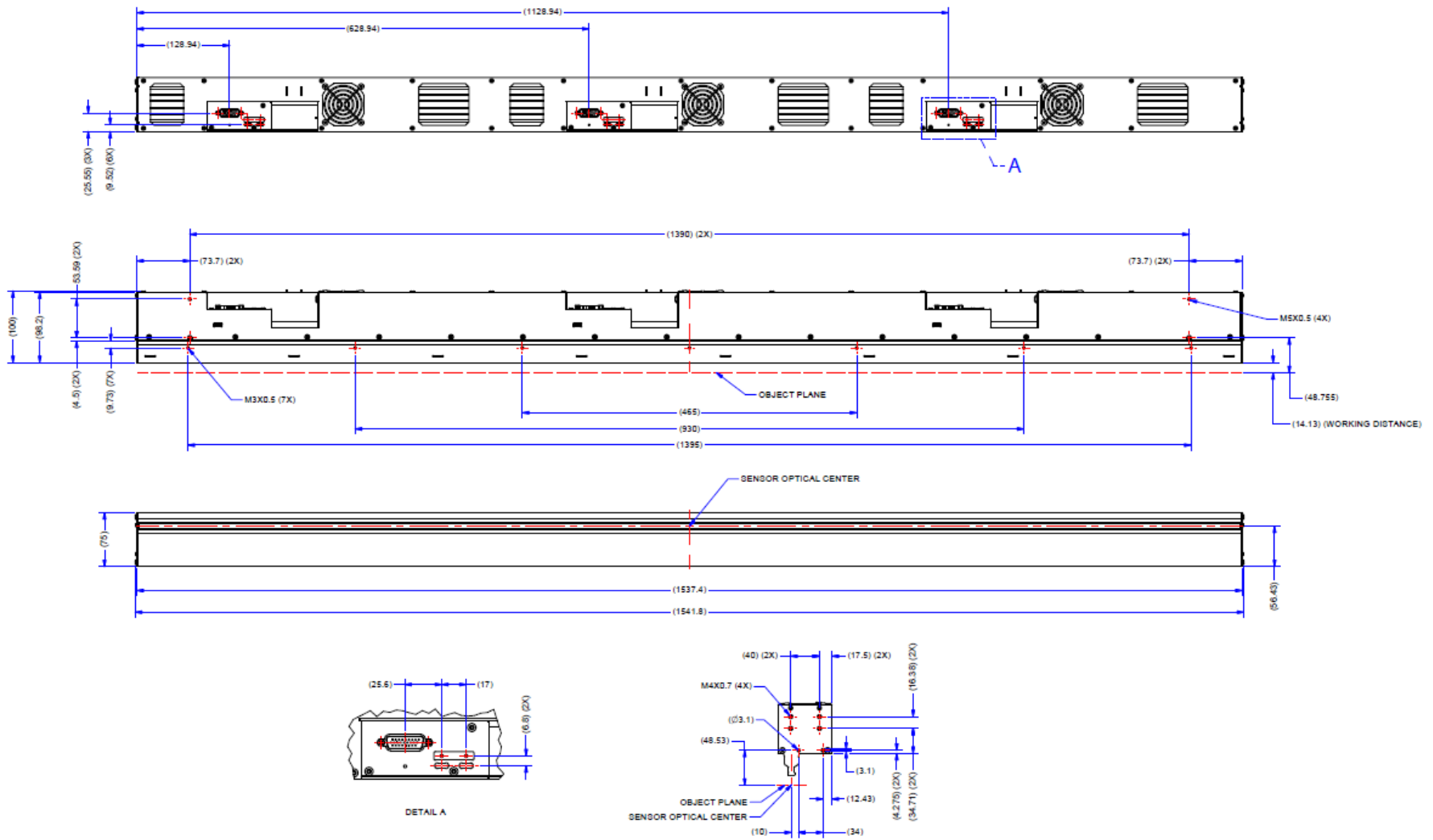
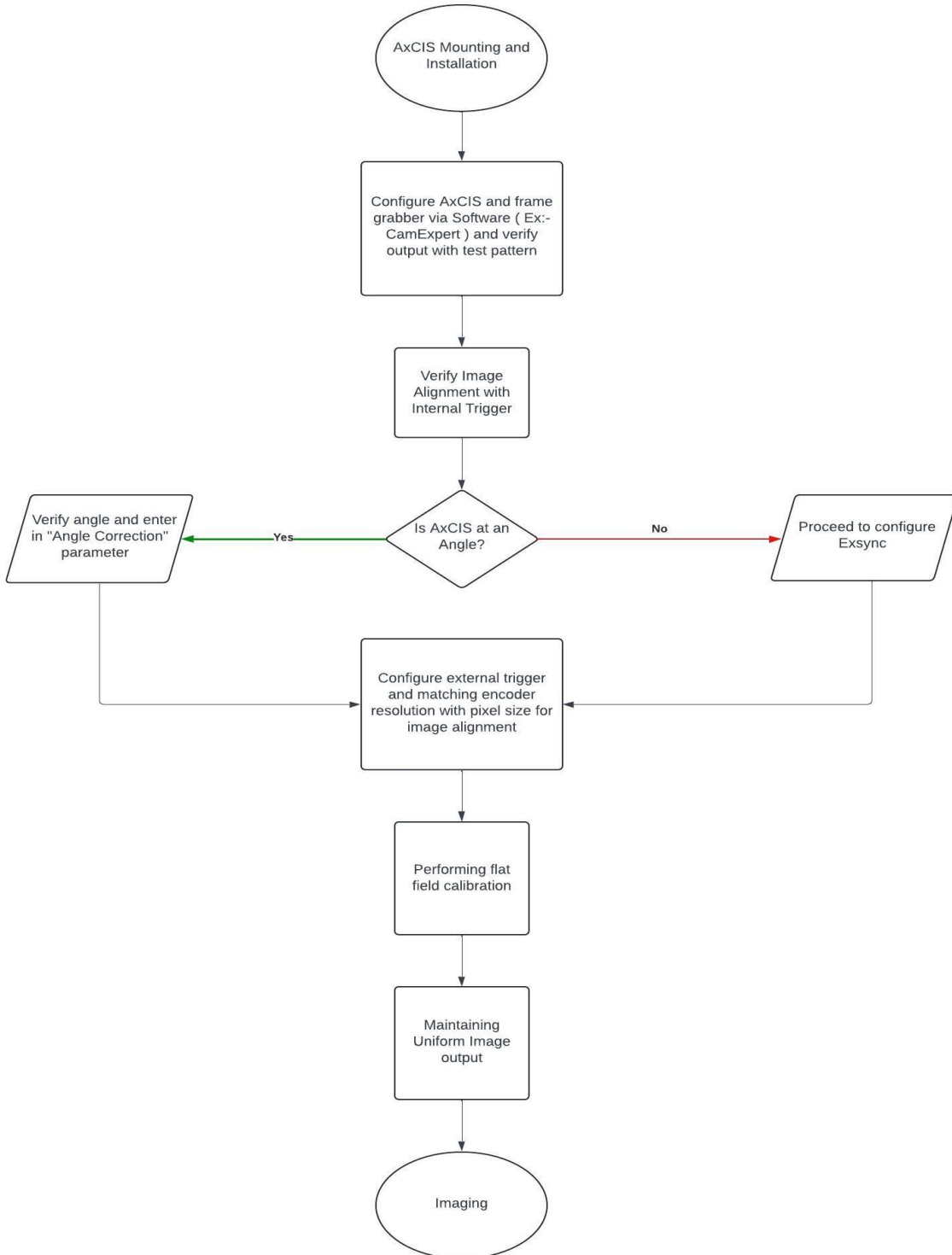

Figure 15: AX-FM-15B12H-00 1500mm CIS Mechanical Drawing (without optional LEDs)

AxCIS Installation and Setup Flowchart



AxCIS Mounting and Installation

AxCIS hardware enclosures include mounting holes on the top, bottom, and sides. Use these holes for mounting as required, considering the following steps:

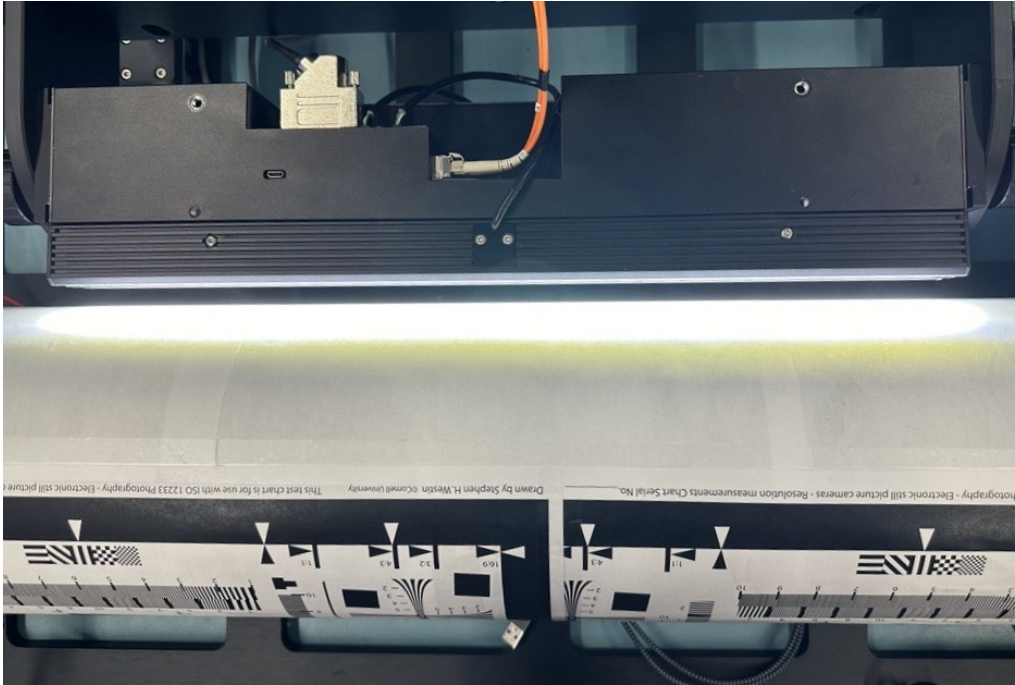

Figure 16: AxCIIS mounted parallel to target

Position the optical axis perpendicular to the target surface.

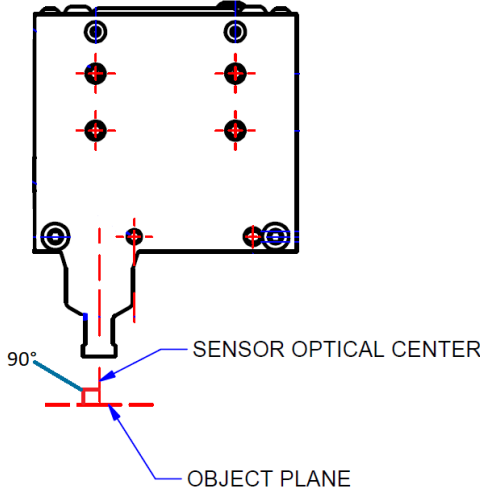

Figure 17: Optical center perpendicular to object surface

Orient the length of the module perpendicular to the direction of the object under inspection. The module's complete length must be aligned perpendicular to the width of the object's direction under inspection. This ensures that the module is correctly oriented relative to the object under inspection.

Ensure the module is parallel to the target surface and aligned along the same axis.

To get a sharp image output ensure both sides of the AxCIS are at a working distance of 13.9 mm (14.13 mm for 1500 mm model) so that the entire field of view is in focus. Incorrectly setting the working distance can result in image defocus and blurring in both horizontal (cross-scan) and vertical (in-scan) directions.

Minor adjustments to the working distance ($\pm < 0.5$ mm) can be made based on the sharpness and focus of the output image.

Irregular or Non-Linear Target Surface

If the AxCIS is mounted above a target surface that is irregular or non-linear (not flat or curved), it may not be possible to have equal working distances at both ends of the AxCIS when mounted.

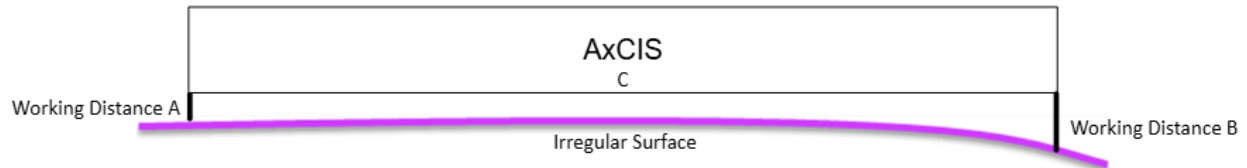

In this case, rotate the AxCIS around the center, such that the working distances are as equal as possible. Next, adjust the vertical height to obtain the best focus across the entire image plane.

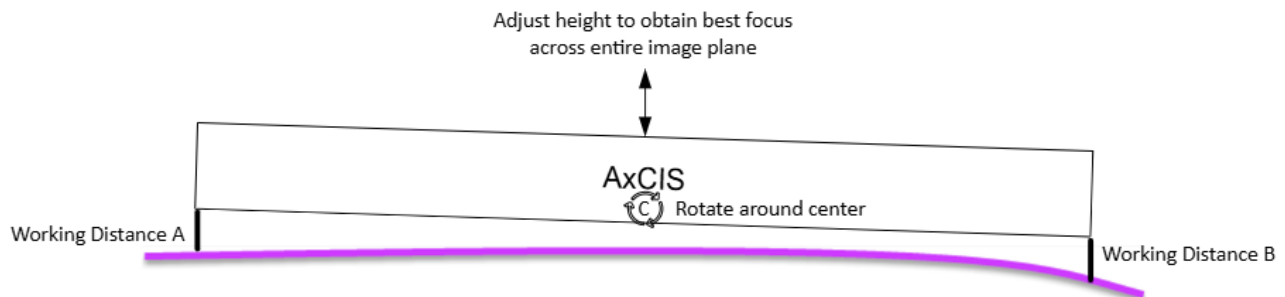

Install & Configure Frame Grabber and Software

Because of the high bandwidth of AxCIS, a compatible Teledyne DALSA frame grabber Xtium2-CLHS FX8 (OR-A8S0-FX840), or equivalent, is recommended. For more details see the Teledyne DALSA website: <http://www.teledynedalsa.com/en/products/imaging/frame-grabbers>



Figure 18: Xtium2-CLHS FX8 (OR-A8S0-FX840) CLHS Frame Grabber

A GenICam compliant XML device description file is embedded with the module firmware. It allows GenICam compliant applications to recognize the module's capabilities, once connected.

Installing Sopera LT gives you access to the CamExpert GUI, a GenICam compliant application.

The Xtium2-CLHS FX8 frame grabber four bidirectional SFP+ modules that supports up to 4 lanes and acquisition of up to 4 independent cameras. This allows a single frame grabber to connect the AxCIS 700 or 800 mm model, with each of its two modules connected with 2 LC optical cables for the maximum line rate.

The Xtium2-CLHS-FX8 LC (OR-A8S0-FX820) is also suitable but has two SFP+ modules to support 2 AxCIS modules using a single LC cable each, or a one AxCIS module using two LC cables.

The following table lists the possible AxCIS model and frame grabbers configurations.

Table 13: AxCIS Model and Frame Grabber Configurations

Frame Grabber	Configuration	AxCIS Model		
		400 mm	600 / 700 / 800 mm	1500 mm
Xtium2-CLHS FX8 (4 port)	2 CLHS cameras (Full bandwidth)	up to 2 cameras 2 LC cables / module	1 camera 2 LC cables / module	Requires 2 frame grabbers 1 camera 2 LC cables / module
	4 CLHS cameras	up to 4 cameras 1 LC cable / module	up to 2 cameras 1 LC cable / module	1 camera 1 LC cable / module
Xtium2-CLHS FX8 LC (2 port)	1 CLHS camera (Full bandwidth)	1 camera 2 LC cables / module	Requires 2 frame grabbers 1 camera 2 LC cables / module	Requires 3 frame grabbers 1 camera 2 LC cables / module
	2 CLHS cameras	up to 2 cameras 1 LC cables / module	1 camera 1 LC cables / module	Requires 2 frame grabbers 1 camera 1 LC cables / module

Cable Connections to Frame Grabber

The Parent LC fiber optic cables are connected to the frame grabber port 1 and 2; the Child to port 3 and 4. One or two LC fiber optic cables are supported; using 2 cables per module allows for higher bandwidth and corresponding higher possible maximum line rates. For 400 mm variant, one or two LC fiber optic cables can be connected to port 1 and 2.

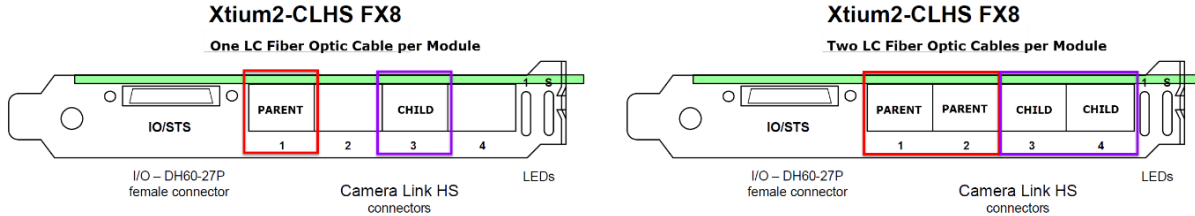
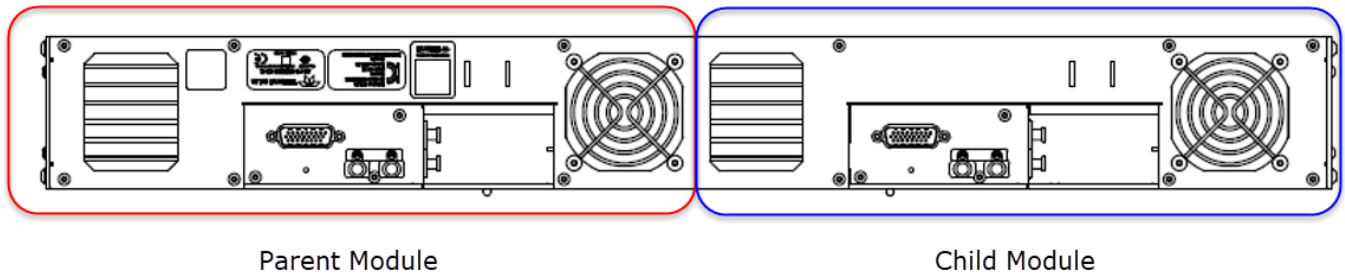

Figure 19: Xtium2-CLHS Camera Link HS Connections for AxCIS Parent & Child Modules

Parent & Child Modules

For Axcis models with multiple modules, the parent module is easily identified as child modules are always on the side next to (adjacent) the parent module's fan.



Shaft Encoder and External Triggers

Typically, shaft encoder and external triggers are connected to the frame grabber through the I/O connector using the DH40-27S cable (OR-YXCC-27BE2M1). Alternatively, triggers can also be connected directly to the camera using the GPIO pins; refer to the AxCIS user manual for more information.

Selecting the Required Firmware Configuration

To complete the installation, update the Xtium2-CLHS FX8 firmware when prompted; select Automatic to update the firmware (to default configuration) or select Manual to choose an alternate configuration). Refer to the Xtium2-CLHS FX8 documentation for complete details on the installation procedure.

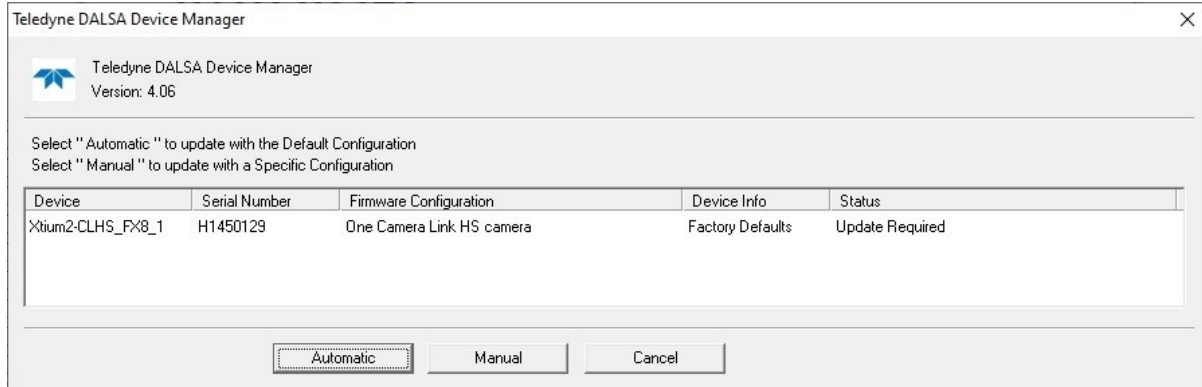

Figure 20: Teledyne DALSA Device Manager

NOTE

When using a single AxCIS module, select the default firmware configuration **One Camera Link HS camera**.

When using an AxCIS with 2 modules, such as the 700 or 800 mm version, the frame grabber must use firmware configuration Two Camera Link HS cameras.

When using 3 or 4 AxCIS modules, select Four Camera Link HS cameras (note that modules will be limited to one LC cable only).

The firmware configuration is set using the Teledyne DALSA Device Manager tool, included with the frame grabber driver installation, and available through the Windows Start menu.

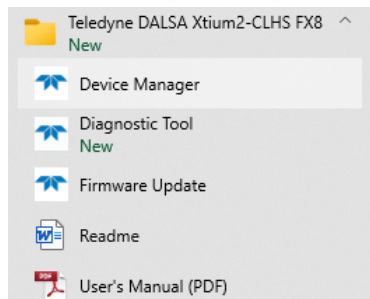

Figure 21: Teledyne DALSA Device Manager Windows Start Menu Shortcut

Setting Up for Imaging

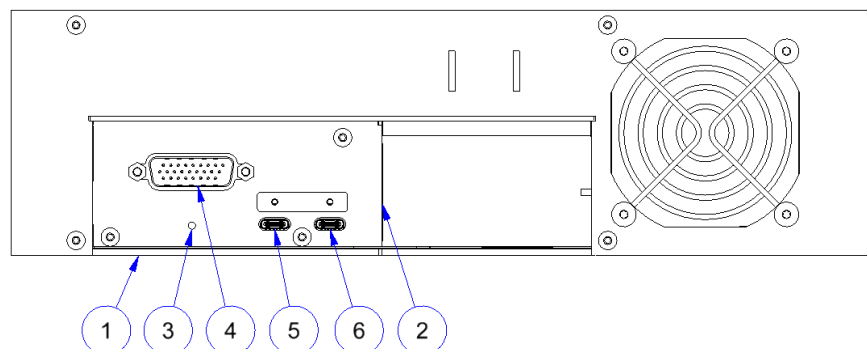

Figure 23. Module I / O Connectors

Camera I / O Connectors

- 1) USB-A Port – Factory use only.
- 2) Data and control connectors – two LC Fiber pairs.
- 3) LED status indicator.
- 4) Power and GPIO connector: +24 V DC, two Input, four Output, 26-pin HD D-Sub connector.
- 5) LED array#1 power.
- 6) LED array#2 power.

Powering the Module

WARNING

When setting up the camera's power supply follow these guidelines:

The 24V supply must be isolated from frame ground of the power supply to prevent potential ground loop issues.

- Before connecting power to the module, verify the power supply voltage.
- Apply the +24 V. Incorrect voltages may damage the camera. The allowed margin is $\pm 10\%$
- There will be no current draw and the unit will not turn on below 21.6 V
- Protect each module section with a 5-amp slow-blow fuse or circuit breaker between the power supply and the module.
- Do not use the shield on a multi-conductor cable for ground.
- Keep power leads as short as possible in order to reduce voltage drop.
- Use high quality supplies in order to minimize noise

NOTE

If your power supply does not meet these requirements, then the module performance specifications are not guaranteed.

Power and GPIO Connections

The module uses a single 26-pin high density D-Sub male connector for power, trigger and strobe signals.

26-pin High Density D-Sub Signal Details

The following figure shows the pinout identification when looking at the module's 26-pin male HD D-Sub connector. The table below lists the I/O signal connections.

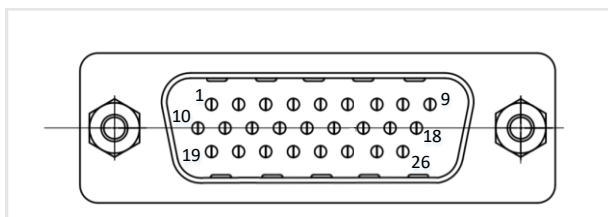

Figure 24: 26-pin high density D-Sub Pin Numbering

Table 14: 26-pin HD D-Sub Pin Assignment

Pin Number	Signal Input / Output	Signal Details	Notes
1	Input	Encoder Phase A+	RS422 Signal
2	Input	Encoder Phase A-	RS422 Signal
3	Input	Encoder Phase B+	RS422 Signal
4	Input	Encoder Phase B-	RS422 Signal
5		+24V Power	All power connections must be connected
6		+24V Power	All power connections must be connected
7		+24V Power	All power connections must be connected
8		Power Ground	All ground connections must be connected
9		Power Ground	All ground connections must be connected
10	Output	Line#1+	RS422 Signal
11	Output	Line#1-	RS422 Signal
12	Output	Line#2+	RS422 Signal
13	Output	Line#2-	RS422 Signal
14		+24V Power	All power connections must be connected
15		+24V Power	All power connections must be connected
16		+24V Power	All power connections must be connected
17		Power Ground	All ground connections must be connected
18		Power Ground	All ground connections must be connected
19	Output	Line#3+	RS422 Signal. Strobe Trigger Source: Plane1, Plane2, Both
20	Output	Line#3-	RS422 Signal. Strobe Trigger Source: Plane1, Plane2, Both
21	Output	Line#4+	RS422 Signal. Strobe Trigger Source: Plane1, Plane2, Both
22	Output	Line#4-	RS422 Signal. Strobe Trigger Source: Plane1, Plane2, Both
23		Signal Ground	Do not use for power ground
24		Reserved. Do not connect	
25		Power Ground	All ground connections must be connected
26		Power Ground	All ground connections must be connected

NOTE

For the AxCIS 700 or 800 mm, if using a shaft encoder, only a single connection (GPIO pins 1 to 4) to the Parent module is required; encoder signals are automatically transmitted to the Child module.

WARNING

All 12 pins of +24V and Power Ground must be connected to the power supply before turning the power on. Failure to do that could cause a burn. The minimum wire gauge is 22AWG per pin.

Caution: camera surface may become hot.

The wire gauge of the power cable should be at least 22 AWG per pin to accommodate a surge during power-up of at least 5 amps with a minimum voltage drop between the power supply and module sections. The module has a single +24 Volt supply per section. If there is a voltage drop between the power supply and module, ensure that the power supply voltage is at least 24 volts plus this voltage drop. The module input supply voltage can be read using CamExpert. The module will not power up below 21.6 V.

A factory 2.5 meter power cable is available (accessory part number AC-CA-00424-00-R).

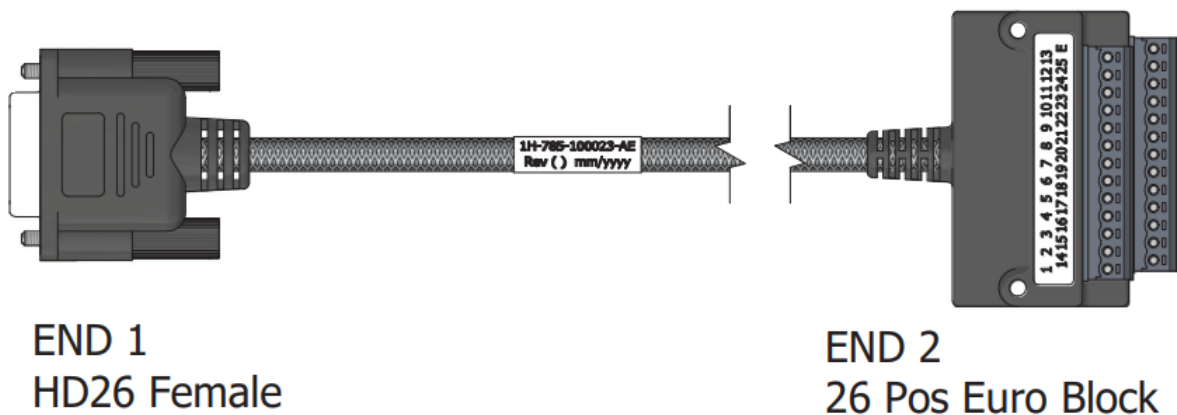

Figure 25: Cable Accessory AC-CA-00424-00-R

PINOUT		
END 1	COLOR CODE	END 2
1	BLACK	1
2	WHITE	2
3	RED	3
4	GREEN	4
5	ORANGE	5
6	BLUE	6
7	WHT/BLK	7
8	RED/BLK	8
9	GRN/BLK	9
10	ORG/BLK	10
11	BLU/BLK	11
12	BLK/WHT	12
13	RED/WHT	13
14	GRN/WHT	14
15	BLU/WHT	15
16	BLK/RED	16
17	WHT/RED	17
18	ORG/RED	18
19	BLU/RED	19
20	RED/GRN	20
21	ORG/GRN	21
22	BLK/WHT/RED	22
23	WHT/BLK/RED	23
24	NC	24
25	RED/BLK/WHT	25
26	GRN/BLK/WHT	25
HSG	SHIELD	E

Figure 26: Cable Accessory AC-CA-00424-00-R Wiring Diagram

For user's wanting to build custom cables, an available mating connector is an Amphenol CONEC (part #: 164A17019X)

To meet the requirements of CISPER xxx, FFC xxx, and IEC xxx, Teledyne DALSA recommends adding a hinged ferrite core to each power cable close to the plug as shown below. The ferrite core is required to reduce the emissions came from the power cable for safety purposes. The suggested part is Wurth 74271221 or similar. Once the part is locked on the cable, it requires a key to open again. Wurth 74271 can be bought separately to unlock the ferrite core.



Figure 27: Cable with Hinged Ferrite Core

Using Spera CamExpert

CamExpert is the camera interfacing tool supported by the Spera library. When used with an AxCIS module, CamExpert allows a user to test all AxCIS module operating modes. In addition, CamExpert can be used to save the module's user settings configuration to the module; for information on how to do so see the [Saving & Restoring Camera Setup Configurations](#) section.

CamExpert can also be used to upgrade the AxCIS module's software.

An important component of CamExpert is its live acquisition display window. This window allows verification of timing or control parameters in real-time, without need for a separate acquisition program.

The central section of CamExpert provides access to the camera features and parameters.

NOTE

The examples shown are for illustrative purposes and may not entirely reflect the features and parameters available from the module model used in your application.

CamExpert Panes

The CamExpert application uses panes to organize the selection and configuration of camera files or acquisition parameters. The main window includes 3 main panes; Device Selector, Parameters and Display.

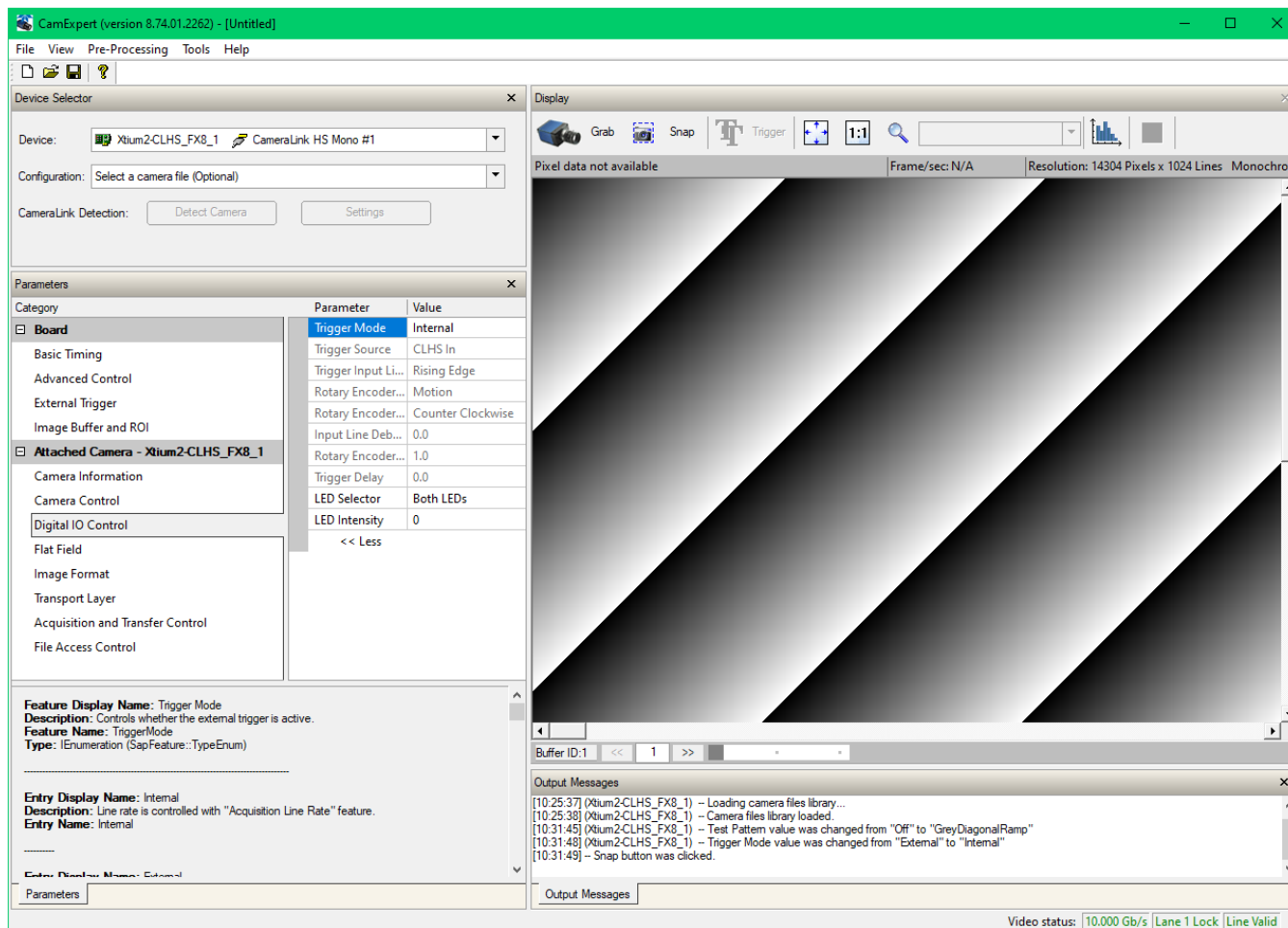



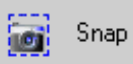
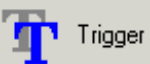

Figure 28: CamExpert Frame Grabber Control Window

Device Selector pane: View and select from any installed Spera acquisition device. Once a device is selected, CamExpert will only show acquisition parameters for that device. Optionally, select a camera file included with the Spera installation or saved previously.

Parameters pane: Allows the viewing or changing of all acquisition parameters supported by the acquisition device. CamExpert displays parameters only if those parameters are supported by the installed device. This avoids confusion by eliminating parameter choices when they do not apply to the hardware in use.

Display pane: Provides a live or single frame acquisition display. Frame buffer parameters are shown in an information bar above the image window.

Control Buttons: The display pane includes CamExpert control buttons. These are:

	<p>Acquisition control button: Click once to start live grab, click again to stop.</p>
	<p>Single frame grab: Click to acquire one frame from device.</p>
	<p>Trigger button: With the I/O control parameters set to Trigger Enabled, click to send a single trigger command.</p>
	<p>CamExpert display controls: (these do not modify the frame buffer data) Stretch image to fit, set image display to original size, or zoom the image to virtually any size and ratio.</p>
	<p>Histogram / Profile tool: Select to view a histogram or line/column profile during live acquisition or in a still image.</p>

Output Message Pane: Displays messages from CamExpert or the device driver.







At this point you are ready to start operating the camera, acquire images, set camera functions and save settings.

Establishing Module Communications

Status LED

When powering up the module, the status LED on the back will indicate one of the following conditions:

Table 15: LED States

LED State		Description
Off		Module is not powered up or is waiting for the software to start.
Constant Red		The module Built-In Self-Test (BIST) status is not good. See BIST status for diagnosis. CamExpert can be used to get the BIST value from the module (using the Power-on Status feature).
Blinking Red		The module has shut down due to the internal temperature exceeding 80°C.
Blinking Orange		Powering Up. The microprocessor is loading code.
Blinking Green		Hardware is good but the CLHS connection has not been established or has recently been broken.
Constant Green		The CLHS Link has been established and the module is ready for data transfer to begin.

Using CamExpert to Connect to an AxCIS Module

When the module's status LED state is steady green:

- CamExpert will search for installed Sapera devices.
- In the **Devices** list, the connected frame grabber and available cameras will be shown.

For the AxCIS models with two modules, CameraLink HS Mono #1 and #2 are available, which correspond to the Master and Child modules.

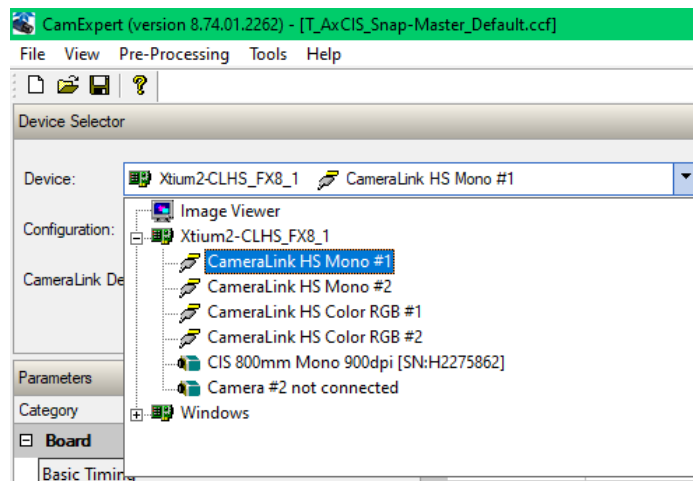

Figure 29: CamExpert Device Selector

For the color module, select CameraLink HS Color RGB #1:

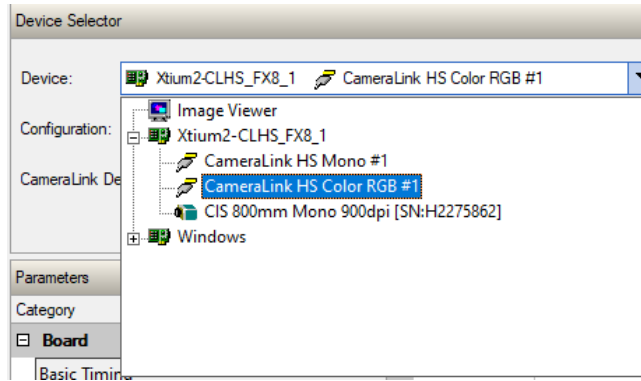

Figure 30: CamExpert Device Selector: CameraLink HS Color RGB #1

NOTE

Multiple Instances of CamExpert: Cameras longer than 400 mm incorporate multiple modules (imaging sections) each with a separate interface to the host frame grabber. For example, the 700 or 800 mm version uses 2 modules (Parent and Child). These are treated as separate modules each requiring their own CamExpert instance (CameraLink HS Mono #1 and #2). Note that models with multiple imaging modules ensure image alignment is maintained across the entire field of view.

Setting the CLHS Cable Configuration

In the camera section's Transport Layer category, set the number of LC fiber optic cables used by the module in the Next CLHS Device Configuration feature; One Cable One Lane or Two Cables One Lane.

This must be done for each module, Parent and Child, as required.

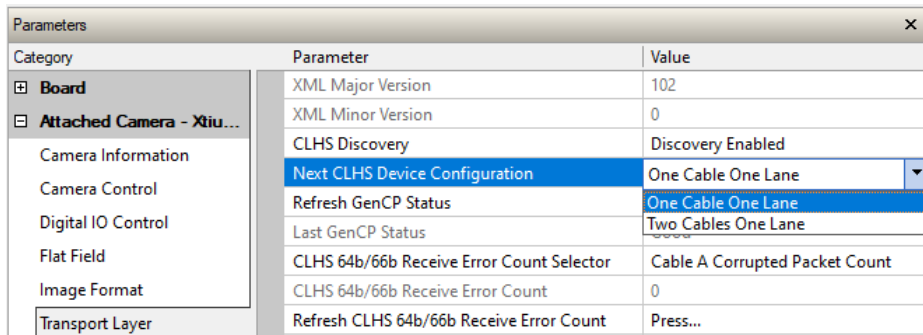

If the *Next CLHS Device Configuration* is modified, reset the camera to initiate the CLHS discovery process.

In the Board section Basic Timing category, verify that the *Data Lanes* parameter is set to the number of cables, 1 or 2. In addition, ensure that *Camera Type* is set to Linescan.

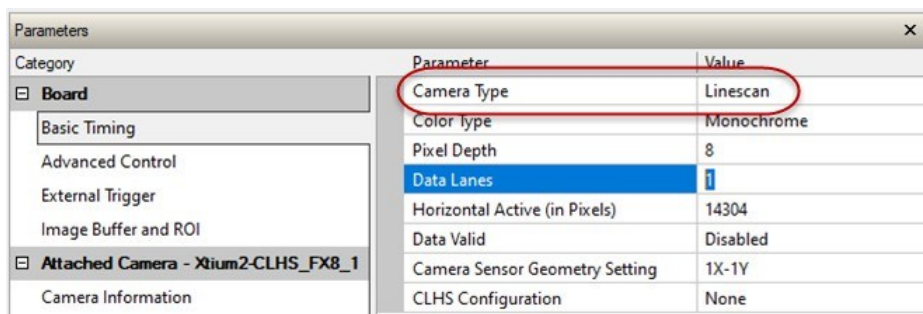

Basic Settings to Verify

In the frame grabber Basic Timing category, verify that the Camera Type is Linescan. Verify that the Color Type and Pixel Depth parameters are set according to module type (color or monochrome) Pixel Format setting.

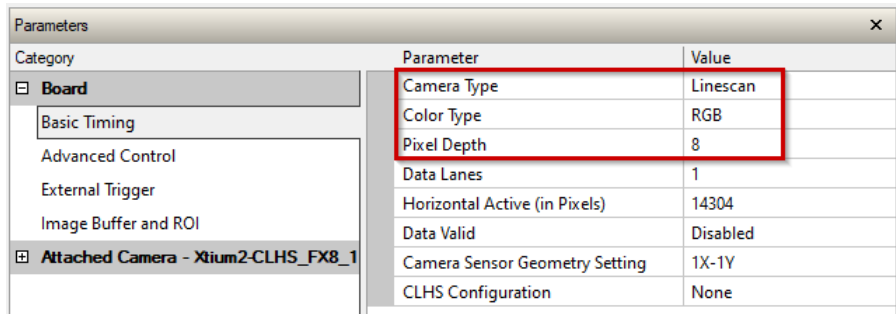

Figure 31: CamExpert Frame Grabber Basic Timing Settings

Also check that the frame grabber's Image Buffer Format is set appropriately to correspond to the module's Pixel Format.

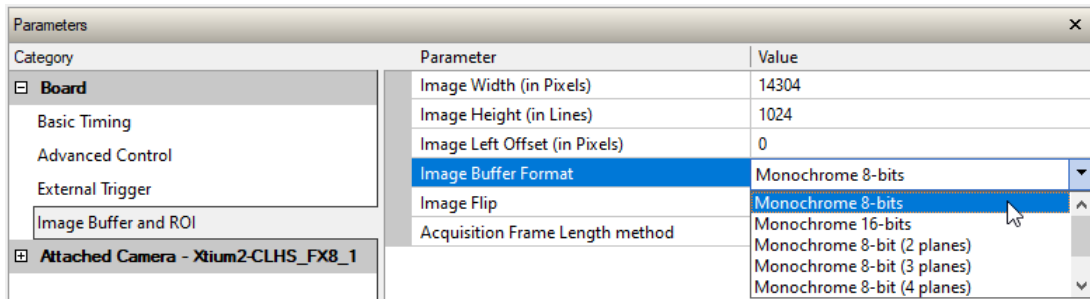

Figure 32: CamExpert Frame Grabber Image Buffer Format Feature

Establishing Data Integrity

To validate that the AxCIS is transmitting data and it is being received by the frame grabber, use the module's internal triggering. This allows for initial imaging with a static object and no encoder input is required.

In CamExpert, set the Trigger Mode feature, available in the Digital IO category, to Internal.

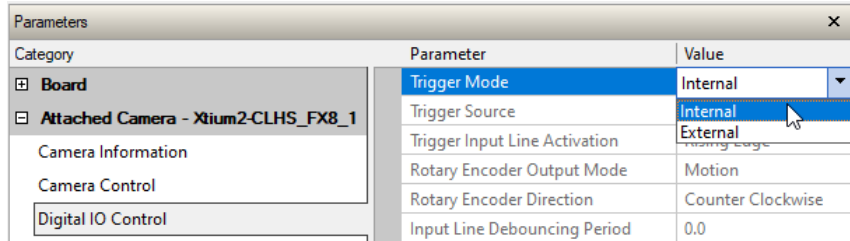

Figure 33: CamExpert Trigger Mode Feature

In the Image Format category, use the Test Pattern feature to enable the module to output a test pattern.

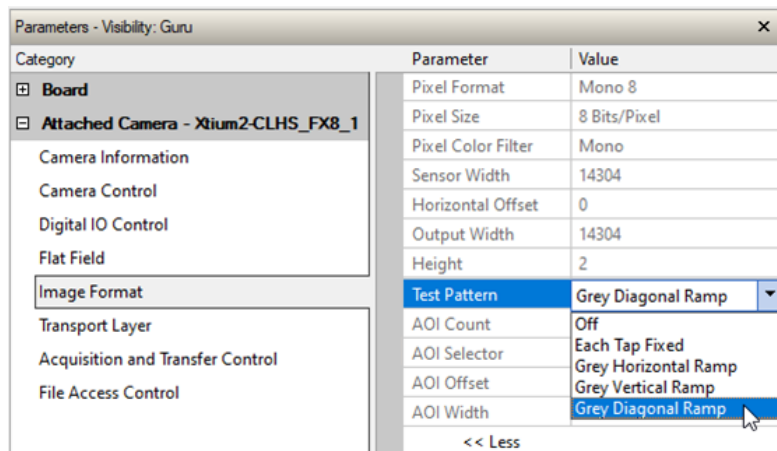

Figure 34: CamExpert Test Pattern Feature

Click **Grab** to capture, display and analyze the test pattern image to verify the integrity of the connection.

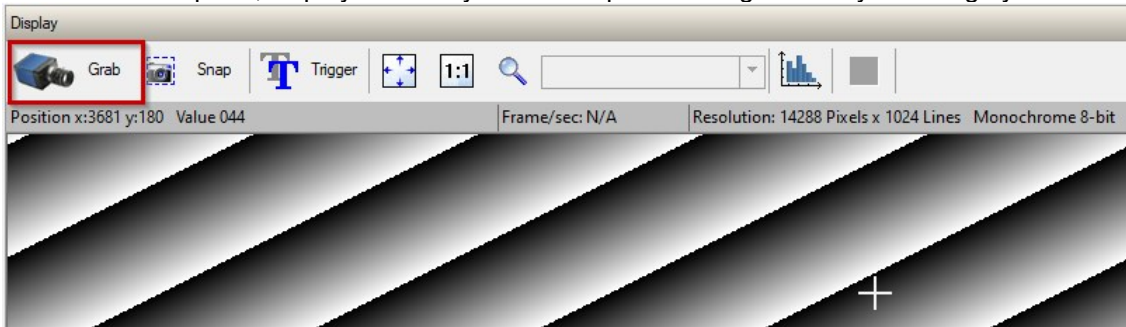
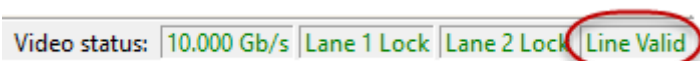
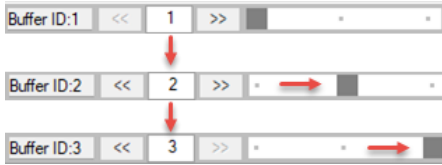

Figure 35: CamExpert Grab With Test Pattern

The Video status bar should show the Line Valid as green.



The buffer navigation pane should also toggle rapidly between Buffer IDs.



NOTE

The Test Pattern function only supports Monochrome 8-bits image format; it does not support other formats, such as Monochrome 8-bits (2 planes) used with Dual Exposure mode.

If the test pattern is not correct, check the cable connections and the frame grabber setup; refer to the Test Patterns – What Can They Indicate? section for more information on troubleshooting.

Scan Direction

The AxCIS modules require the user to indicate the direction of travel of the object being imaged.

The diagram below shows the orientation of forward and reverse with respect to the module body looking at its rear face.

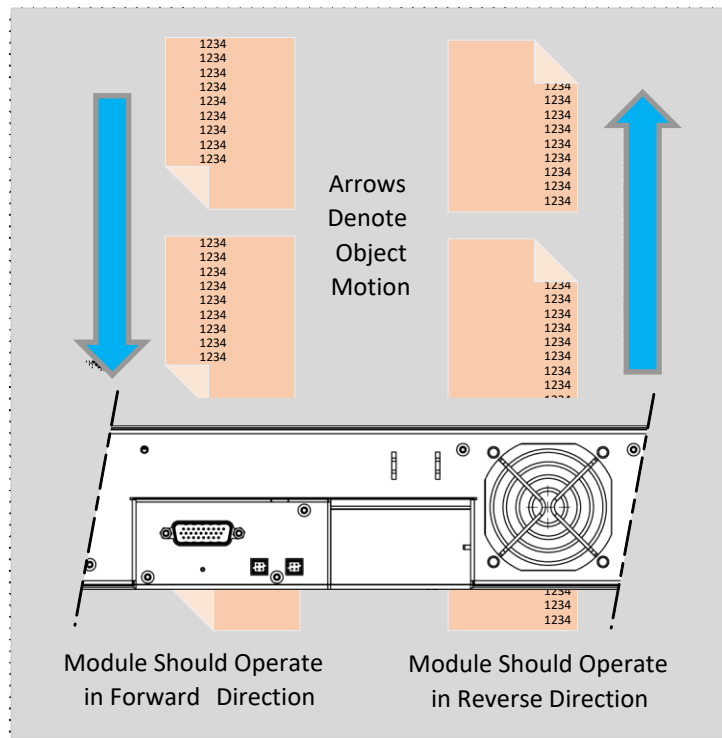

Figure 36: Example of Object Movement and Module Direction

The source of the scan direction is set using the Direction Source feature. The options are:

- **Internal:** Uses the Internal Scan Direction feature to set the direction to either Forward or Reverse.

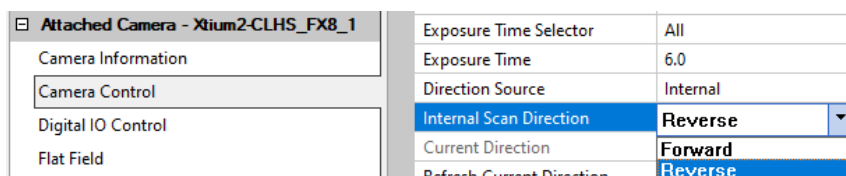

Figure 37: CamExpert Internal Scan Direction

- *Line 2*: pin 3 & 4 on the GPIO connector, or
- *Rotary Encoder*: using pins 1, 2, 3 & 4 of the GPIO connector; only available when *Trigger Source* is “RotaryEncoder” and *rotaryEncoderOutputMode* is set to “Motion”.

A correct scan direction can easily be seen in live imaging as the image appears “normal”, sharp, focused and well-aligned. If the working distance is not set properly the image will be out of focus and blur will occur in both horizontal (cross-scan) and vertical (in-scan) directions.

If scan direction shifts are seen between each of the sensor’s 25 mm field of view (see below), the scan direction is set incorrectly.

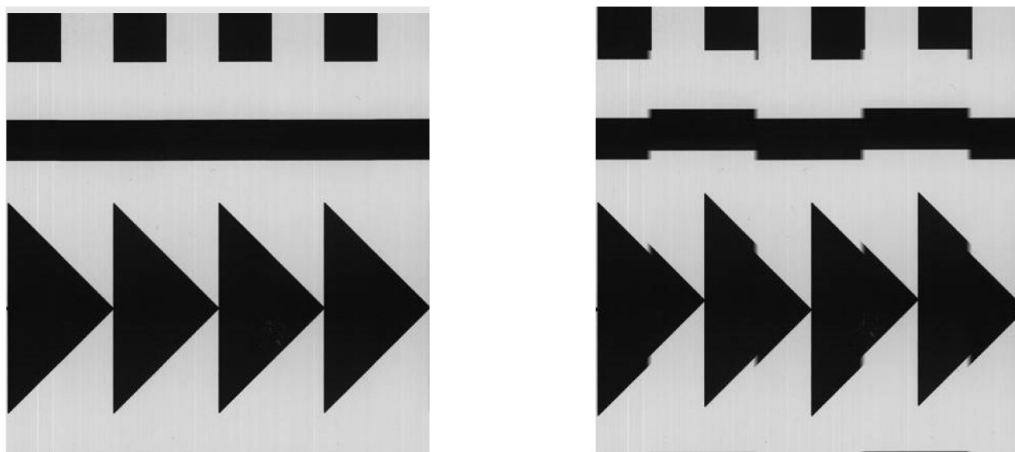

Figure 38. (Left) Image with correct scan direction. (Right) Image with incorrect scan direction.

Camera Features

This section is intended to be a progressive introduction to camera features, including explanations of how to use them effectively.

Pixel Format

See the section Image Format Category in Appendix A for GenICam features associated with this section and how to use them.

Related Features: [Pixel Format](#), [Acquisition Start](#) and [Acquisition Stop](#)

AxCIS outputs data in the following formats:

Table 16: Output Data Formats

Output Format	Camera Models	Frame Grabber Image Buffer Format
Mono8	All monochrome models	Monochrome 8-bits
Mono12	All monochrome models	Monochrome 16-bits
RGB8	All color models	RGB Planar 8-bits
RGB12	All color models	RGB Planar 16-bits

Use the [PixelFormat](#) feature, available in the Image Format category, to set the required pixel depth.

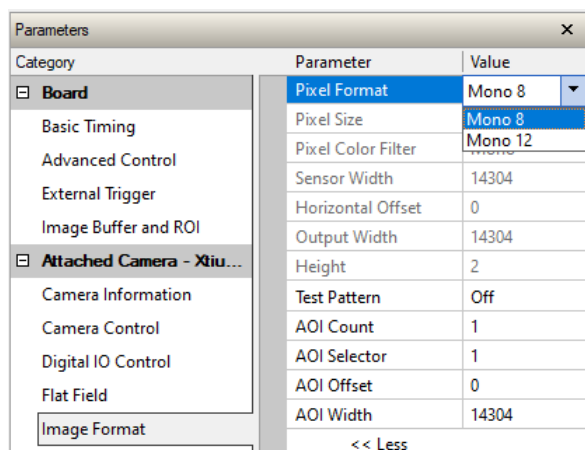

Figure 39: CamExpert Pixel Format Feature (monochrome device)

For example, to change pixel format:

- In Acquisition and Transfer Control category, click on the *Acquisition Stop* feature's field; the Acquisition Status will display "Not Acquiring".

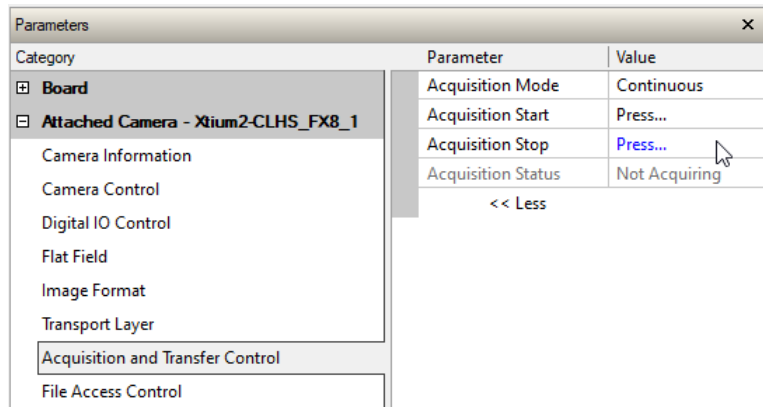

Figure 40: CamExpert Acquisition Stop Feature

- In Image Format category, set *Pixel Format* to the required format.

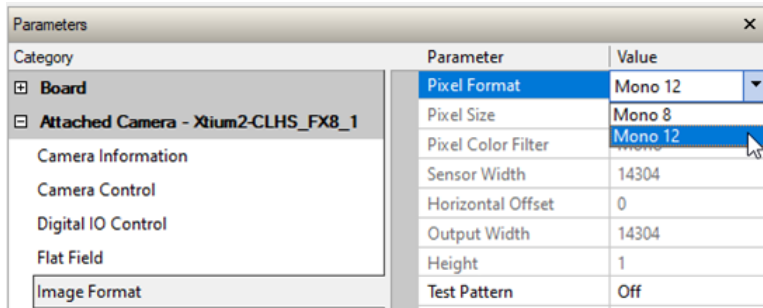

Figure 41: CamExpert Pixel Format Feature (monochrome device)

- In the host frame grabber's Basic Timing category, set *Pixel Depth* to the appropriate corresponding value.

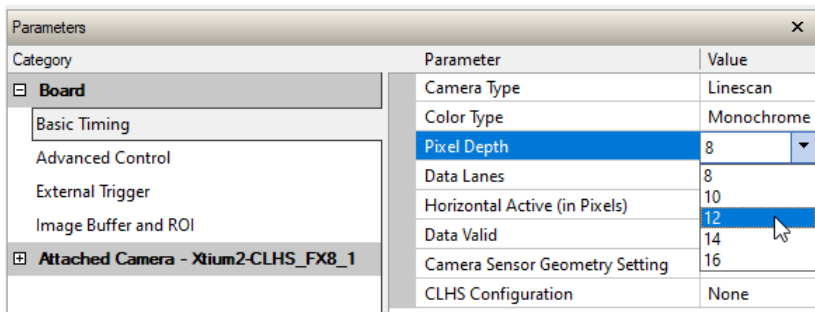

Figure 42: CamExpert Frame Grabber Pixel Depth Feature

In addition, in the Image Buffer and ROI category, verify that the *Image Buffer Format* is set to the appropriate corresponding format.

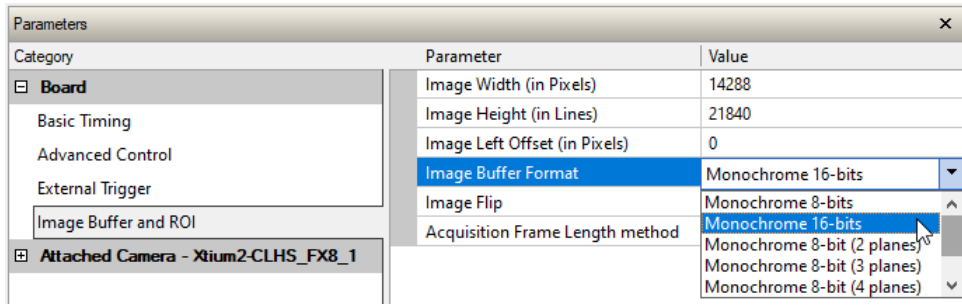

Figure 43: CamExpert Frame Grabber Image Buffer Format Feature (monochrome models)

- In the camera's Acquisition and Transfer Control category, click on the *Acquisition Start* feature's field; the Acquisition Status will display "Acquiring".

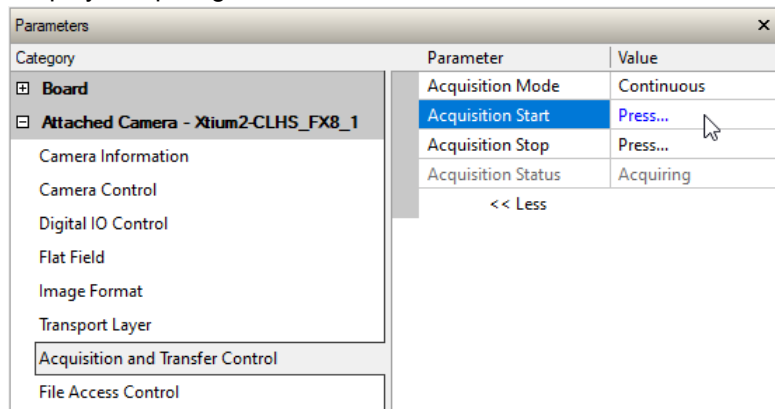

Figure 44: CamExpert Acquisition Start Feature

Sensor Saturation

The sensor has a saturation point $2^n - 2$, where n is bit depth.

For example, in 8-bit mode, the saturation point is $2^8 - 2 = 256 - 2 = 254$ DN. In 10 bit mode, the saturation point is $2^{10} - 2 = 1024 - 2 = 1022$ DN.

The data sent out from the camera can only be in two formats: 8-bit or 12-bit. Therefore, in 10-bit mode data sent to the framegrabber is automatically converted to 12-bit format. A conversion from 10 bit to 12 bit is equivalent to a multiplication by 4. This has no negative impact on the image or the data, but the observed pixel values will increment in steps of 4. This also results in a saturation of $1022 * 4 = 4088$ DN.

Monochrome Module Specific Features

Dual Exposure Mode (HDR)

Some inspection applications may have areas where specific features must be identified that have very bright and very dark areas within the same field of view. Optimizing for the bright areas may result in too much noise to detect features in dark areas and optimizing for the dark areas may result in saturating the image in bright areas.

The AxCIS module has a dual exposure mode that can overcome these opposing requirements by imaging with a long exposure time for one row while concurrently imaging with a short exposure with the second row. The long exposure time row can be configured to detect the desired features in the dark areas while the short exposure can be configured to detect features in the bright areas.

To set up dual exposure mode see the *Exposure Mode*, *Exposure Time* and *Exposure Time Selector* features, which are available in the Camera Control category.

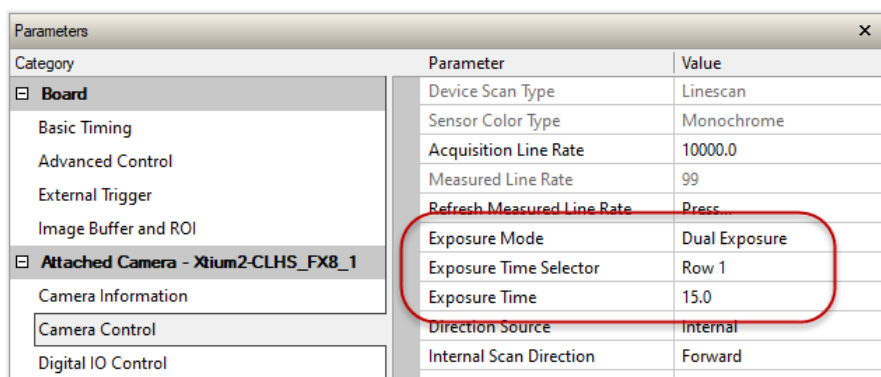

Figure 45: CamExpert Exposure Features

The maximum exposure time is dictated by the period of the line rate. The minimum exposure times is 2 μ s. Therefore, the dynamic range from dark to bright areas can be very large as dictated by the line rate and available illumination intensity.

The long and short exposure time rows are output from the module separately, one after the other, and captured by the frame grabber as two image planes that can be processed separately or appropriately combined by the user to meet their specific needs.

Since two rows are being processed in dual exposure mode, the maximum line rate is half that with normal monochrome imaging, that is, 60 kHz maximum.

The two rows are spatially separated in the scan direction. However, the module ensures the long and short exposure time images are aligned.

If the module is at an angle or the encoder resolution is not 84 μ m (300 dpi), 56 μ m (450 dpi), 42 μ m (600 dpi) or 28 μ m (900 dpi), use the *Angle Correction* and/or the *Encoder Resolution* features to enter the system configuration to ensure image alignment.

NOTE

For monochrome models, when **Dual Exposure** mode is enabled (set using the Exposure Mode feature), the module outputs data to the frame grabber in a 'planar' format; the corresponding lines are output separately one after the other.

For color models dual exposure mode is not available; however separate exposure times can be set for the Red / Blue and Green rows (see the Color Module Specific Features section).

When using Dual Exposure mode, set the frame grabber's Image Buffer Format, available in the Image Buffer and ROI category, to Monochrome 8-bit (2 planes) for Mono8 or Monochrome 16-bit (2 planes) for Mono12.

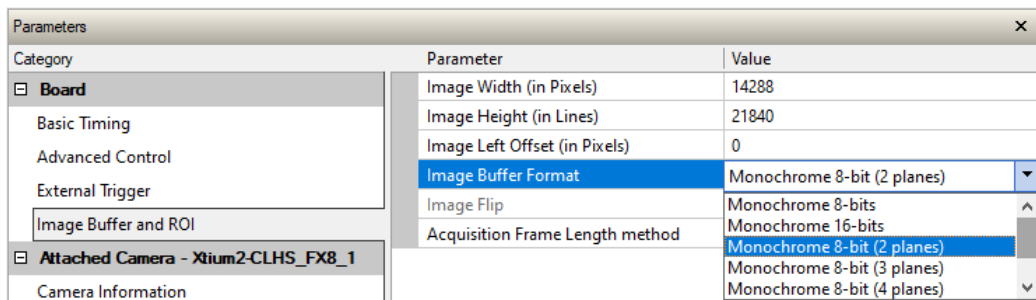

Figure 46: CamExpert Frame Grabber Image Buffer Format: Dual Exposure Mode

In CamExpert, the image buffer plane to display can be selected using the drop-down list:

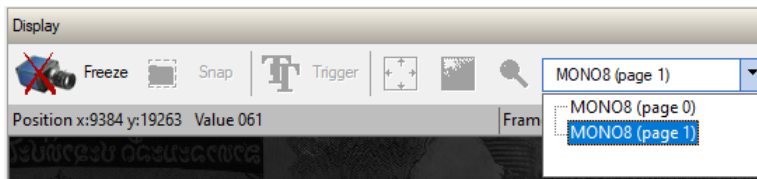

Figure 47: CamExpert Image Buffer Plane Selector

Refer to the frame grabber documentation for further details on selecting input and output pixel formats.

NOTE

Pixel Format, and associated features, can only be changed when the image transfer to the frame grabber is stopped. Refer to the Acquisition and Transfer Control Category in the appendix for details on stopping and starting the acquisition.

Color Module Specific Features

The AxCIS color sensor has 3 rows of 14 um pixels for blue, green and red:

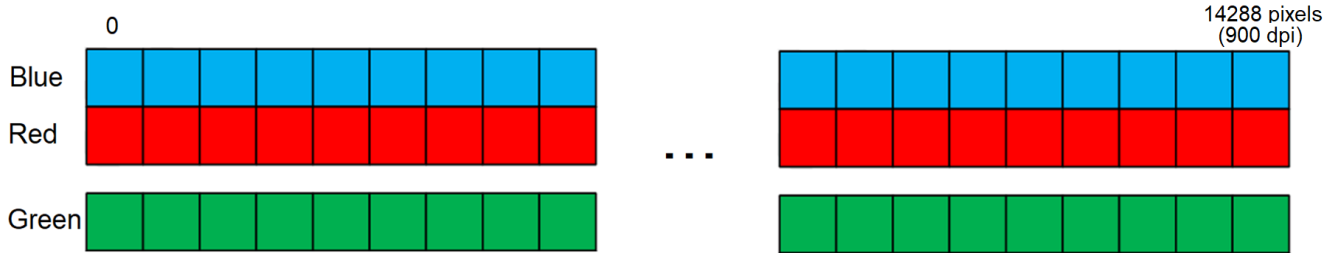

Figure 48: AxCIS Color Sensor Rows

Exposure Times

The AxCIS color model supports separate exposure times for the Red / Blue rows and Green row; use the [Exposure Time Selector](#), available in the Camera Control category, to select either Red / Blue or Green, then set the [Exposure Time](#) feature to the required exposure.

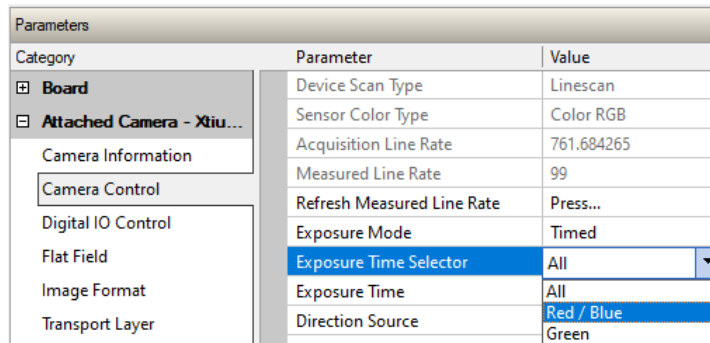

Figure 49: CamExpert Exposure Time Selector

Output Formats

Supported output formats are RGB8 Planar or RGB12 Planar, depending on the selected [PixelFormat](#).

In the frame grabber Basic Timing category, set the Color Type to RGB.

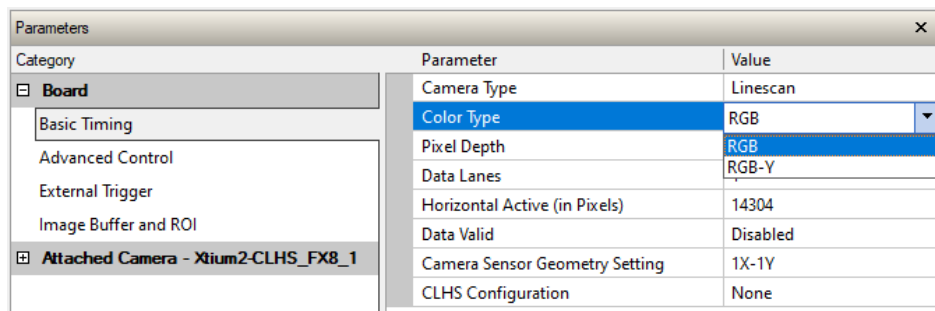

Figure 50: CamExpert Frame Grabber Color Type

In the frame grabber Image Buffer and ROI category, set the Image Buffer Format to either RGB Planar 8-bits, or RGB Planar 16-bits for RGB12 pixel format.

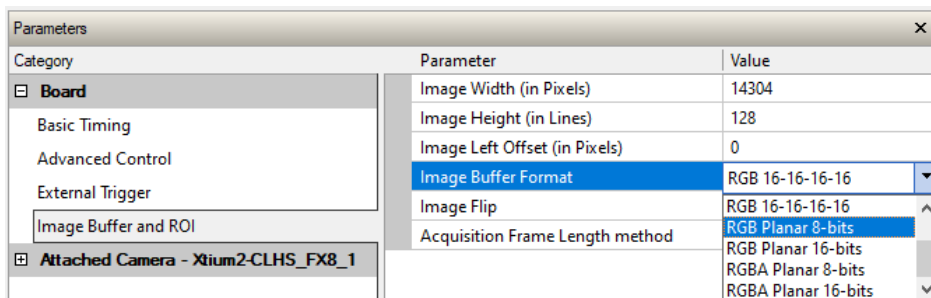

Figure 51: CamExpert Frame Grabber Image Buffer Format

Row Gains

Each color row can have its own gain applied. Use the Row Selector feature, available in the Camera Control category, to choose an individual row or All Rows, then use the Row Gain feature to specify the gain value.

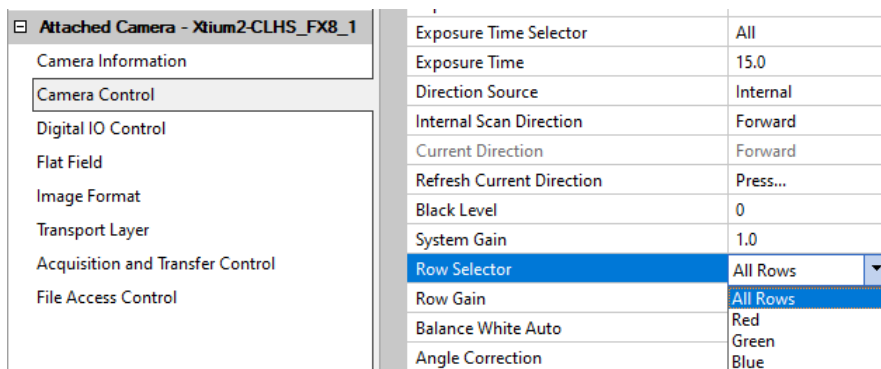

Figure 52: CamExpert Row Selector Feature

Color Transformation Matrices

The RGB values output by the camera depend on the spectral responsivity of the camera and on the color temperature of the light source. For example, with a light that is more blue than red, the blues will be brighter and the reds dimmer. AxCIS color modules include color transformation matrices (3x4) for color correction. Three different matrices can be saved, allowing for different lighting environments. Applying a matrix transform to the RGB data from the sensor performs this colour correction. The transform is represented by the following equation:

$$\begin{bmatrix} Red_{out} \\ Green_{out} \\ Blue_{out} \end{bmatrix} = \begin{bmatrix} Gain00 & Gain01 & Gain02 \\ Gain10 & Gain11 & Gain12 \\ Gain20 & Gain21 & Gain22 \end{bmatrix} \cdot \begin{bmatrix} Red_{in} \\ Green_{in} \\ Blue_{in} \end{bmatrix} + \begin{bmatrix} Offset1 \\ Offset2 \\ Offset3 \end{bmatrix}$$

The following features, available in the Camera Control category, allow the user to modify these matrices if necessary.

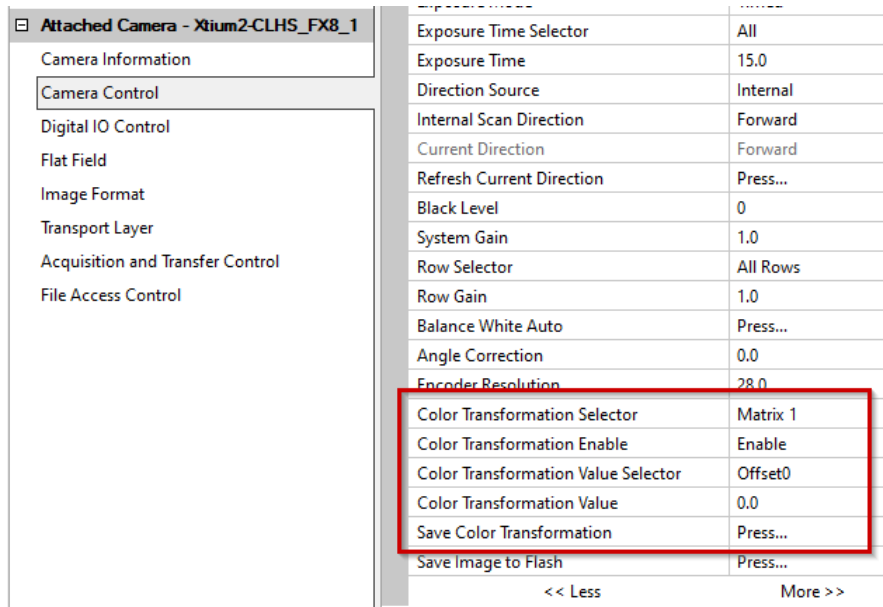
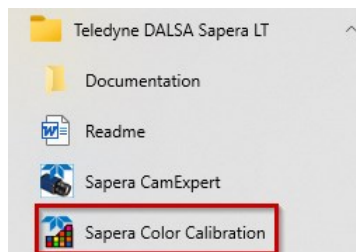

Figure 53: CamExpert Row Color Transformation Features

Use the Color Transformation Selector to choose the matrix to modify, then use the Color Transformation Value Selector to choose the coefficient to modify by setting its Color Transformation Value. When modifications are completed, click the Save Color Transformation field. Use the Color Transformation Enable feature to select whether to apply the selected matrix.

The color transformation matrix uses a custom file format *.ccor. Sapera LT includes the Sapera Color Calibration tool which allows for the creation of color transformation matrices using a Gretag-Macbeth color chart and a specified illuminant. Refer to the tool documentation for information on how to generate a matrix.



The generated .ccor file can then be uploaded to the AxCIS color module using the File Access Control dialog:

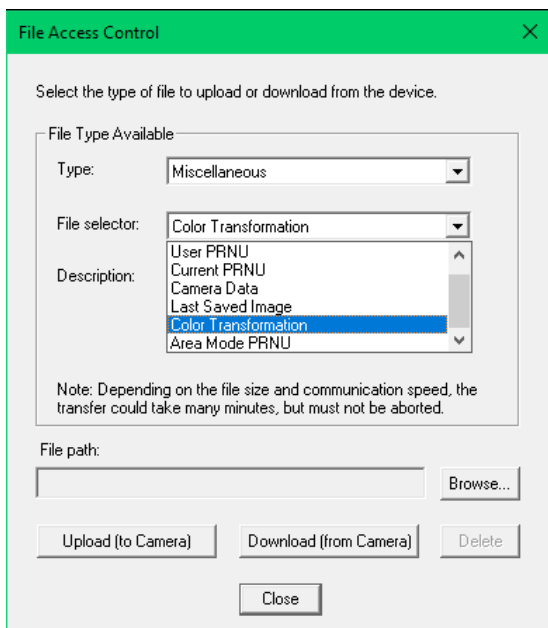

Figure 54: CamExpert File Access Control Dialog

NOTE

The factory color transformation matrix is enabled by default. This matrix was generated using the optional LED lighting; if a different light source is used, it is recommended to generate a new matrix for this light source.

Automatic White Balancing

The *Balance White Auto* feature, available in the Camera Control category, is used to calculate the RGB gain adjustments, which are then applied to subsequent snaps or grabs. Click "Press..." to execute the automatic white balance function. The reference color component is automatically selected so that the minimum component's gain becomes 1.00. Automatic white balancing operates under the assumption of a color neutral scene.

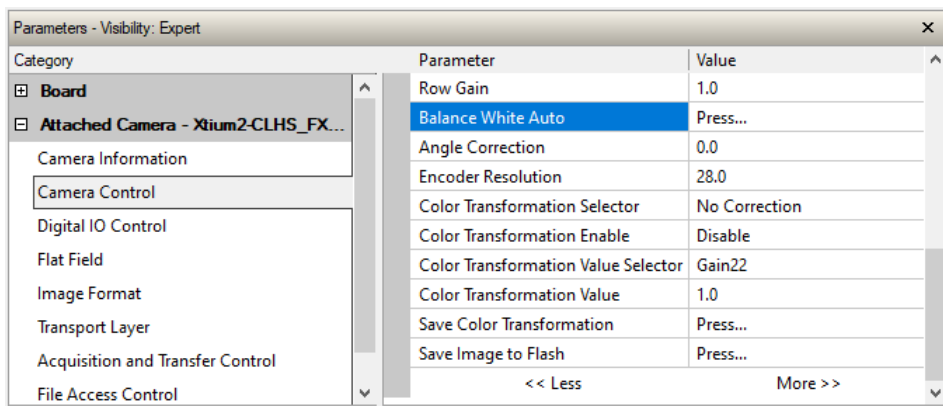

Figure 55: CamExpert Balance White Auto Feature

NOTE

Computer monitors have wide variations in displaying color. Users should consider using professional monitors which have factory calibrated fixed presets conforming to sRGB or AdobeRGB color spaces.

Blue / Red Crosstalk Correction

Crosstalk is the unintended influence of pixels from one color channel on the response of pixels in another channel. Crosstalk may also result when the camera is mounted at an angle due to the changes in the angle of incident photons on the pixel structure.

In AxCIS color modules, this effect is most noticeable as an odd/even pattern in the green row as red and blue light affect alternating pixels. This is seen in the green row output as variations in the responsivity between even and odd rows. The image below illustrates how crosstalk from red and blue pixels affects the intensity of green pixels.

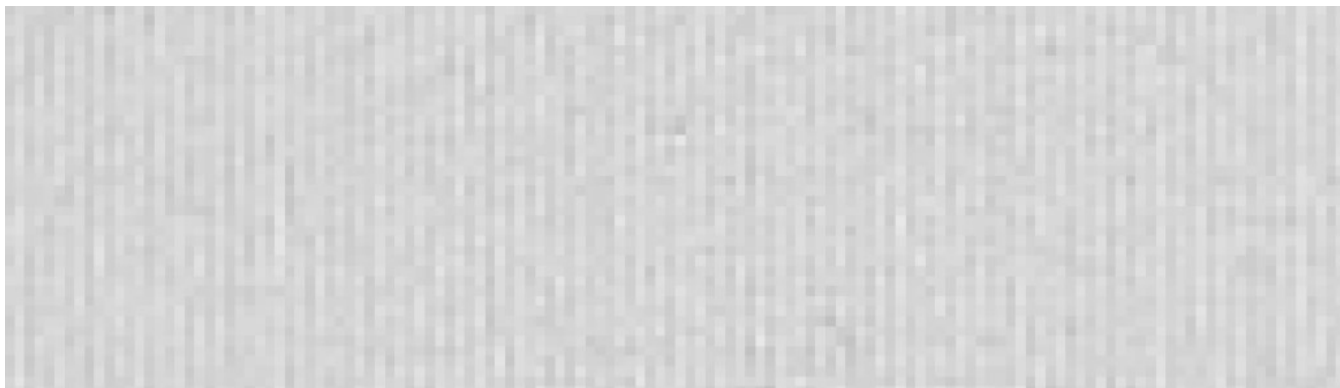

Figure 56: Red / Blue Crosstalk Artifacts in Green Row

At 900 dpi, green pixels experience only minor interference from adjacent red and blue pixels. This effect is negligible and is automatically corrected by the internal algorithm.

At 600 dpi, crosstalk becomes more pronounced due to how the different sensor rows are grouped to form pixels; green pixels are influenced by multiple red and blue neighbors.

To compensate for this effect, the Blue Crosstalk and Red Crosstalk features, available in the Camera Control category, can be adjusted to provide a uniform response.

Attached Camera - Xtiu...	Parent Child Gain	1.0
Camera Information	Refresh Parent Child Gain	Press...
Camera Control	Balance White Auto	Press...
Digital IO Control	Angle Correction	0.0
Flat Field	Encoder Resolution	85.400002
Image Format	Blue Crosstalk	0.0261
	Red Crosstalk	0.0449

NOTE

The Blue Crosstalk and Red Crosstalk features are only available when the Resolution feature (available in the Image Format category) is set to 600 dpi.

Crosstalk Calibration

In most cases, the default calibration will remove most of the crosstalk. However, if the angle of incident light with respect to the sensor changes, the crosstalk correction values may need to be adjusted.

It is recommended to calibrate the crosstalk by using the following steps:

1. Configure the camera with all corrections off (crosstalk, flatfield, color correction).
2. Capture a dark image, a red image under red illumination, and a blue image under blue illumination.
3. Subtract the dark image from the red image and the blue image, then measure the average of the odd Green columns and the average of the even Green pixels in the dark-subtracted red and blue images.
4. On the blue channel of the dark-subtracted blue image, average all pixels and save as B.
5. On the red channel of the dark-subtracted red image, average all pixels and save as R.
6. Calculate the blue crosstalk correction value with the average of the G_{even} and the average of the G_{odd} pixels in the dark-subtracted blue image:

$$\text{Blue Crosstalk correction value} = \frac{\text{abs}(\text{avg}G_{\text{even}} - \text{avg}G_{\text{odd}})}{B} \times 100$$

7. Calculate the red crosstalk correction value with the average of the G_r and the average of the G_b pixels in the dark-subtracted red image:

$$\text{Red Crosstalk correction value} = \frac{\text{abs}(\text{avg}G_{\text{even}} - \text{avg}G_{\text{odd}})}{R} \times 100$$

Enter these values for the Blue Crosstalk and Red Crosstalk.

NOTE

If red and blue illumination are not available, the Blue Crosstalk and Red Crosstalk values can be adjusted manually and the resulting image analyzed until a suitable color correction is determined.

Synchronizing to Object Motion

Acquiring Images: Triggering the Camera

Related Features: [Trigger Mode](#), [Trigger Source](#), [Trigger Activation](#)

Several different methods can be used to trigger image acquisition in the camera:

Internal Trigger

The simplest method is to set the [Trigger Mode](#) feature, available in the Digital IO Control category, to “Internal”.

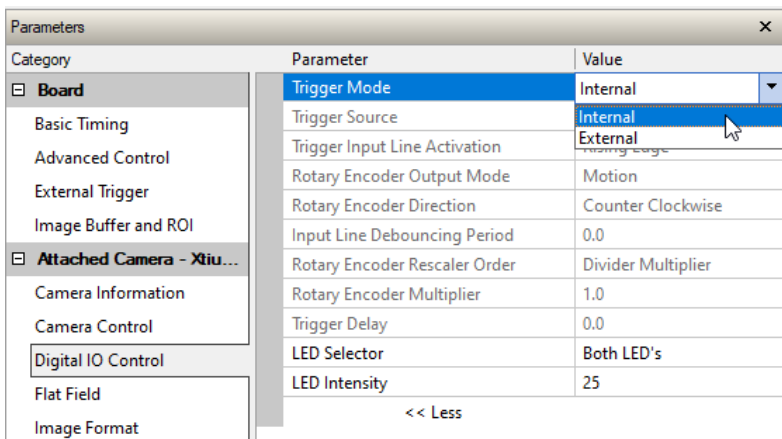

Figure 57: CamExpert Trigger Mode Feature

This results in the camera being triggered by an internal timer, which can be adjusted using the [Acquisition Line Rate](#) feature. This is useful when setting up the camera with a static image.

NOTE

If the object is moving, the internal line rate must match the object speed in mm/sec divided by the selected pixel size of 0.084 mm (300 dpi), 0.056 mm (450 dpi), 0.042 mm (600 dpi) or 0.028 mm (900 dpi) to ensure correct alignment of the sensors' images.

External Triggers

When the Trigger Mode feature is set to “External”, the camera triggers come from a source selected through the Trigger Source feature.

The available sources for the triggers are:

- **CLHS In:** from the Camera Link HS frame grabber
- **Line 1:** pins 1 & 2 (Phase A) of the AxCIS GPIO connector
- **Rotary Encoder:** pins 1, 2, 3 & 4 of the AxCIS GPIO connector

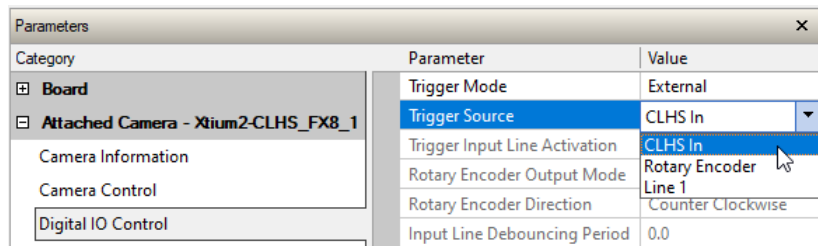

Figure 58: CamExpert Trigger Source Feature

When using Line 1 or Rotary Encoder as the trigger source, the Trigger Input Line Activation feature determines the edge that triggers the camera.

Options are: *Rising Edge, Falling Edge, Any Edge.*

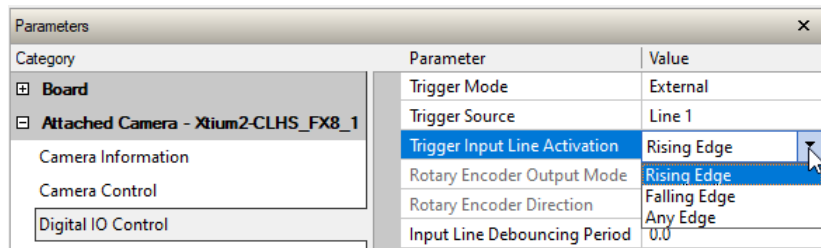

Figure 59: CamExpert Trigger Input Line Activation Feature

When using *Any Edge* be careful that the time between edges does not exceed the maximum line rate of the module. If the line rate is exceeded edges will be ignored.

When using CLHS In, the encoder signal from the frame grabber input is routed to the trigger input of the module via the Camera Link HS data cable.

Use the frame grabber Advanced Control features to set the Line Sync Source for the line trigger. For the Line Trigger Method Setting use Method 2.

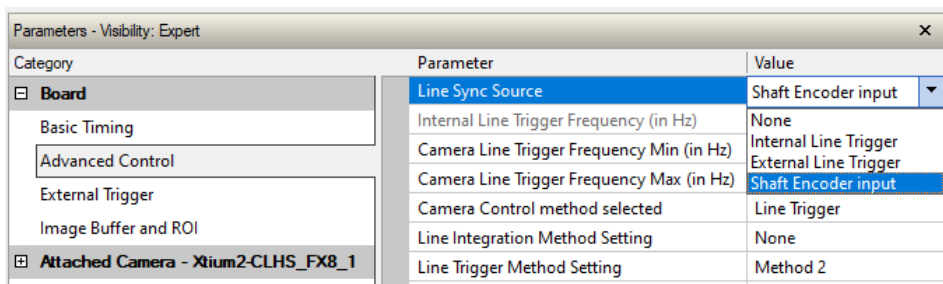

Figure 60: CamExpert Frame Grabber Line Sync Source Feature

If using a frame trigger, set the External Trigger category features as required for the trigger.

The screenshot shows the 'Parameters' dialog box with a tree view on the left and a table of parameters on the right. The tree view is expanded to 'Attached Camera - Xtium2-CLHS_FX8_1' and then to 'External Trigger'. The table lists various parameters and their values.

Parameter	Value
External Trigger	Enable
External Trigger Detection	Rising Edge
External Trigger Level	RS-422
External Trigger Source	External Trigger #1
External Trigger Minimum Duration (in us)	0
Frame Count per External Trigger	1
External Trigger Delay	0
External Trigger Delay Time Base	Nanoseconds
External Trigger Ignore Delay	0
Shaft Encoder Direction	Ignored
Shaft Encoder Edge Drop	0
Shaft Encoder Edge Multiplier	1
Shaft Encoder Order	Device Specific
Shaft Encoder Averaging Enable	Disabled
Shaft Encoder Averaging Pulses (2^N)	1
Shaft Encoder Averaging Period Minimum (in ns)	10000
Shaft Encoder Averaging Period Maximum (in ns)	1000000
External Line Trigger Detection	Rising Edge
External Line Trigger Source	Automatic

Figure 61: CamExpert Frame Grabber External Trigger Feature Category

Line Rate and Synchronization

A continuous stream of encoder trigger pulses, synchronized to the object motion, establishes the line rate. The faster the object's motion is, the higher the line rate. The module can accommodate triggers up to its specified maximum frequency as dictated by the exposure time. If the maximum frequency is exceeded, the module will continue to output image data at the maximum specified. The result will be that some trigger pulses will be missed and there will be an associated distortion (compression and sensor misalignment in the scan direction) of the image data. When the line rate returns to or below the maximum specified, then normal imaging will be reestablished.

Maximum Line Rate

The maximum achievable line rate is determined by the number of cables installed, *Resolution* (selected dpi), *Pixel Format* and *Exposure Mode* settings.

Table 17: Standard Models: Maximum Line Rates

Pixel Format	Exposure Mode	# LC Cables	Maximum Line Rate			
			Per Module	900 dpi	600 dpi	450 dpi
Mono 8 (8-bit)	Timed	2	120192 Hz	120000 Hz	120000 Hz	120000 Hz
		1	60024 Hz	113000 Hz	120192 Hz	120000 Hz
	Dual Exposure	2	60024 Hz	60000 Hz	120192 Hz	60000 Hz
		1	30012 Hz	56000 Hz	60024 Hz	60000 Hz
Mono 12 (12-bit)	Timed	2	80000 Hz	120000 Hz	60000 Hz	120000 Hz
		1	50000 Hz	75000 Hz	60000 Hz	120000 Hz
	Dual Exposure	2	25000 Hz	60000 Hz	50000 Hz	60000 Hz
		1	25000 Hz	25000 Hz	50000 Hz	60000 Hz
RGB 8 (RGB Planar 8-bits)	Timed	2	50000 Hz x 3	60000 Hz x 3	60000 Hz x 3	120000 Hz x 3
		1	25000 Hz x 3	37894 Hz x 3	50000 Hz x 3	60000 Hz x 3
RGB 12 (RGB Planar 16-bits)	Timed	2	33333 Hz x 3	50000 Hz x 3	60000 Hz x 3	60000 Hz x 3
		1	16666 Hz x 3	25000 Hz x 3	33700 Hz x 3	50000 Hz x 3

*AxCIS's maximum line rate values shown here are theoretical. These line rates were achieved using an Xtium2-CLHS FX8 frame grabber (part #: OR-A8S0-FX840) with the CamExpert application as a system setup. The maximum achievable line rate depends on the number of LC cables per module (for example, the 700 or 800 mm camera has 2 modules and the 1500 mm camera has 3 modules) and imaging system (including CPU) used. Depending on your setup, lower line rates may be experienced. The maximum line rate is also limited by the exposure time. For example, to achieve 120 kHz the exposure time must be less than 6.12 μ s.

NOTE

Lower dpi enables higher possible line rates.

For advice on your setup and achieving higher line rates, contact [Teledyne DALSA customer support](#).

Internal Trigger Mode Minimum Line Rate

The minimum line rate for internal trigger is 300 Hz. The modules include special features to prevent accumulation of dark current at very low and stopped line rates. External trigger mode does not have this limit and can trigger down to 0Hz.

Measuring Line (Trigger) Rate

Related Features: [Measured Line Rate](#), [Refresh Measured Line Rate](#)

The *Measured Line Rate* feature reads the actual line (trigger) rate being applied, externally or internally, to the camera.

In CamExpert, in the Camera Control Category, pressing the [Refresh Measured Line Rate](#) field returns the current measured line rate.

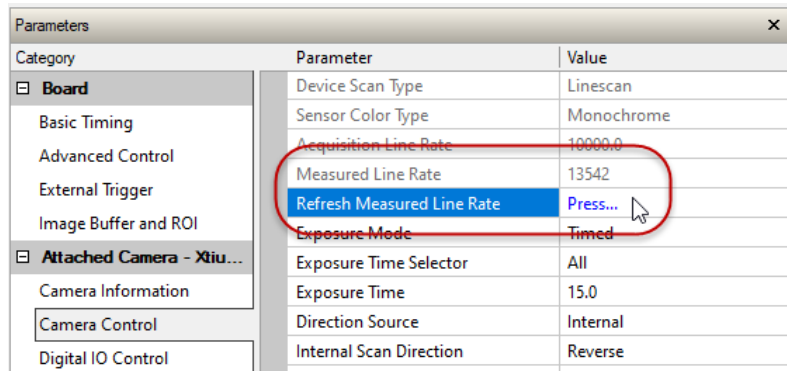

Category	Parameter	Value
Board	Device Scan Type	Linescan
	Sensor Color Type	Monochrome
	Acquisition Line Rate	10000.0
	Measured Line Rate	13542
	Refresh Measured Line Rate	Press...
	Exposure Mode	Timed
Attached Camera - Xiu...	Exposure Time Selector	All
	Exposure Time	15.0
	Direction Source	Internal
	Internal Scan Direction	Reverse

Figure 62: CamExpert Refresh Measured Line Rate Feature

Establishing the Optimal Response

An important AxCIS module performance characteristic is its responsivity and associated noise level at the system's maximum line rate with the required illumination configuration.

Responsivity and noise performance can be assessed using a stationary, plain white diffusing target using the optional LED illumination.

NOTE

To accurately evaluate the module's real-life performance, it is important that the setup is representative of the final system configuration.

The ideal test setup meets the following conditions:

- The correct working distance is established to ensure the setup is in focus.
- The illumination configuration and intensity are equivalent to that planned of the inspection system.
- The module is operated with an exposure time that will allow the maximum line rate of the system to be achieved. The module's internal line rate generator and exposure control can be used for a stationary target.
- The stationary target should not have a texture, such as paper grain.

Image Response Uniformity & Flat Field Calibration

See the section [Flat Field Category](#) in Appendix A for GenICam features associated with this section and how to use them.

Related Features: [Flat Field Correction Mode](#), [Calibrate FPN](#), [Calibrate PRNU](#), [Calibration Algorithm](#), [Flat Field Calibration Target](#), [Clear Coefficients](#), [Row Selector](#)

The sensor pixel responses, illumination intensity profile and the Selfoc Lens Arrays (SLA) transmission characteristics may cause variations in the image response over the field of view.

The module can compensate for optical non-uniformities by using flat field calibration.

- When performing Flat Field (PRNU) calibration, the module should be imaging a front illuminated white target or rear bright field illumination source. The optical setup should be as per the inspection system, including correct working distance, illumination intensity, spectral content and illuminator beam structure.
- Flat field calibration should be performed when the camera temperature has stabilized.
- Flat field calibration adjusts all pixels to have the same value as the peak pixel value or target level, as per the calibration mode selected.
- If the flat field calibration is set to a target level that is lower than the peak value and the system gain is set to a low value, then it is possible that the sensor will maximize its output before the camera's output reaches 255 DN. This can be seen when a portion of the output stops increasing before reaching 255 DN with increasing illumination and the PRNU deteriorates. This effect can be resolved by decreasing the light level or exposure control time.

Following a flat field calibration, all pixels should be at their un-calibrated peak value or target value. Changing gain values now allows the user to make refinements to the operating responsivity level.

NOTE

The best flat field calibration can be achieved by performing it at the mid DN level of the working range used in the operation. Any flat field error associated with residual non-linearity in the pixel will be halved as compared to performing a calibration at the peak value of the operating range. A simple way of performing this is to reduce exposure time to half what is used in the operation in order to get the mid DN level for flat field calibration. Once complete, return the exposure time to its original setting.

Those areas of the image where high roll-off is present will show higher noise levels after flat field calibration due to the higher gain values of the correction coefficients. Flat field calibration can only compensate for up to an 8:1 variation. If the variation exceeds 8:1 then the line profile after calibration will include pixels that are below the uncalibrated peak level.

NOTE

AxCIS has many different modes of operation. It is strongly recommended that the camera be flat fielded for the intended mode of operation and scan direction.

Saving & Loading a PRNU Set Only

See the [Flat Field Category](#) in Appendix A for GenICam features associated with this section and how to use them.

Related Features: [PRNU Current Active Set](#), [Save Calibration](#), [Load Calibration](#)

A user set includes all the “settings” (for example, gain, line rate), FPN (Fixed Pattern Noise) and PRNU (Photo Response Non-Uniformity) coefficients. These three features let you save/load just the PRNU coefficients. Loading a complete user set takes approximately 1 second while loading only the user PRNU coefficients takes less than 200 milliseconds.

Use the User PRNU Set Selector parameter to select the set you want to save or load. There are 17 sets available—16 user and 1 factory.

The *Factory Set* is read-only and contains all ones. Loading the Factory Set is a good way to clear the user PRNU.

Save the current user PRNU coefficients using the “Save User PRNU Set” command. Load the user PRNU coefficients from the set specified using the “User PRNU Set Selector” and the “Load User PRNU Set” command features.

Flat Field Calibration Regions of Interest

See the section [Flat Field Category](#) in Appendix A for GenICam features associated with this section and how to use them.

Related Features: [Flat Field Calibration Offset X](#), [Flat Field Calibration Width](#)

There are occasions when the module’s field of view includes areas that are beyond the material to be inspected.

This may occur when module images off the edge of a panel or web or when an inspection system is imaging multiple lanes of material. The edge of the material or area between lanes may not be illuminated in the same way as the areas of inspection and, therefore, will cause problems with a flat field calibration.

The module can accommodate these “no inspection zones” by defining a Region of Interest (ROI) where flat field calibration is performed. Image data outside the ROI is ignored by the flat field calibration algorithm. The ROI is selected by the user and with the pixel boundaries defined by the pixel start address and pixel width and then followed by initiating flat field calibration for that region. Once set, another ROI can be defined and flat field calibrated.

Maintaining Image Alignment

Adjusting the Encoder (EXSYNC) Input

Image alignment is assured when the encoder (EXSYNC) pulses occur every 84 μm (300 dpi), 56 μm (450 dpi), 42 μm (600 dpi) or 28 μm (900 dpi) of object travel.

The user may find it inconvenient to accurately create 84, 56, 42 or 28 μm encoder (EXSYNC) resolution, but may have another encoder source available at a different resolution. This can be accommodated by using the module's *Rotary Encoder Multiplier* feature, available in the Digital IO category, which multiplies the incoming period from 0.009x to 100x as required to achieve the desired resolution.

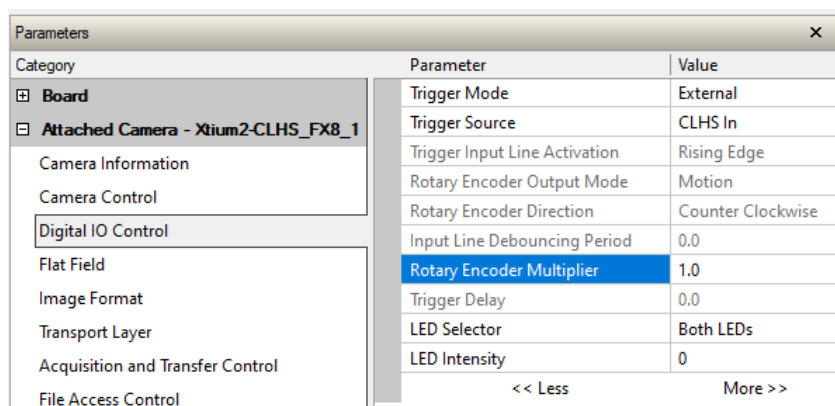

Figure 63: CamExpert Rotary Encoder Multiplier Feature

Users may find the *Rotary Encoder Multiplier* feature easier to use to adjust the shaft encoder pulses than to use the board's shaft encoder multiply/drop methods. However, either technique can be used, or a combination of the features.

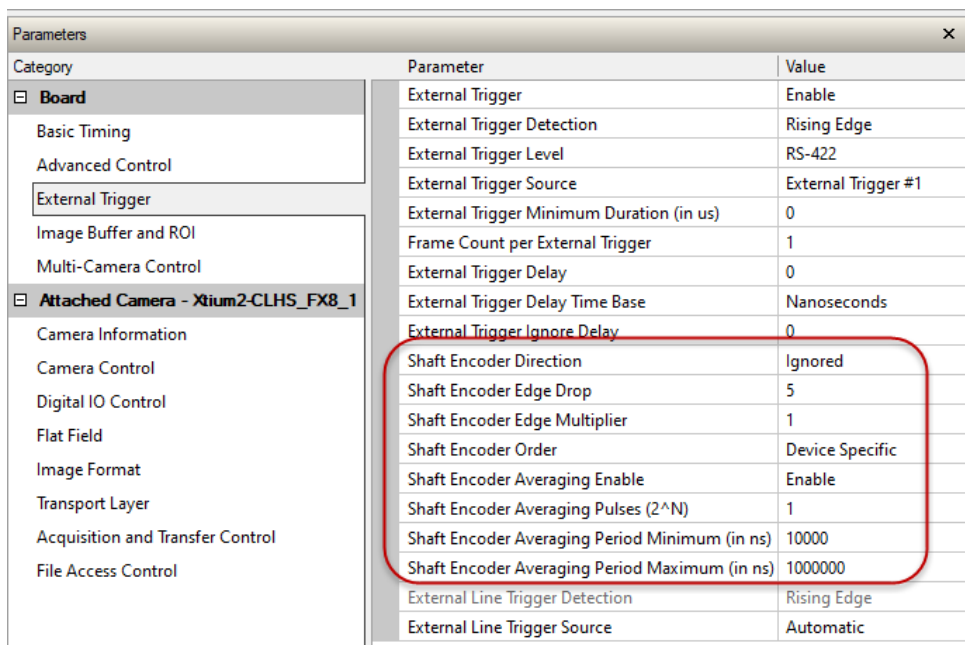

Figure 64: CamExpert Frame Grabber Shaft Encoder Features

The frame grabber establishes the desired encoder resolution by a multiply-drop function if the pulse rate is low or a drop-multiply function if the pulse rate is high. This is set using the board's Shaft Encoder Order parameter.

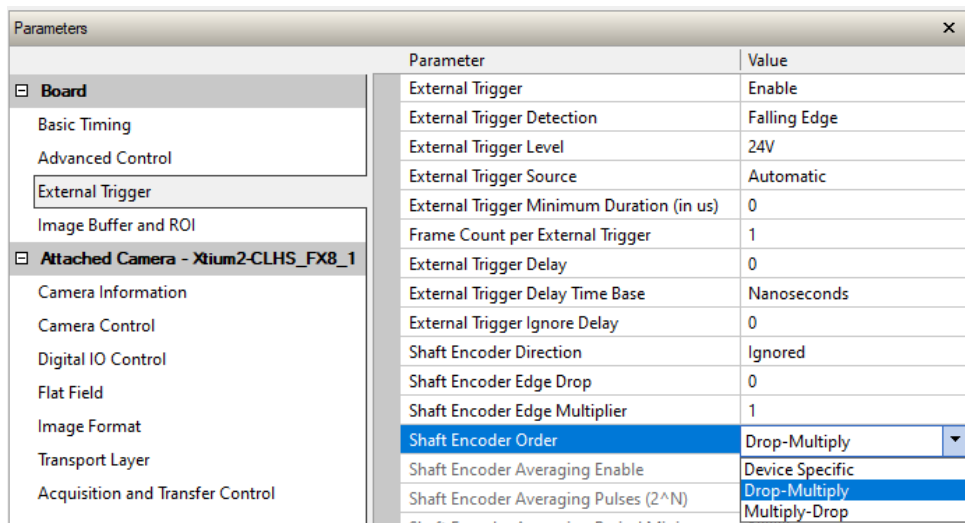

Figure 65: CamExpert Frame Grabber Shaft Encoder Order Feature

The Shaft Encoder Edge Multiplier can be 1, 2, 4, 8, 16 or 32x.

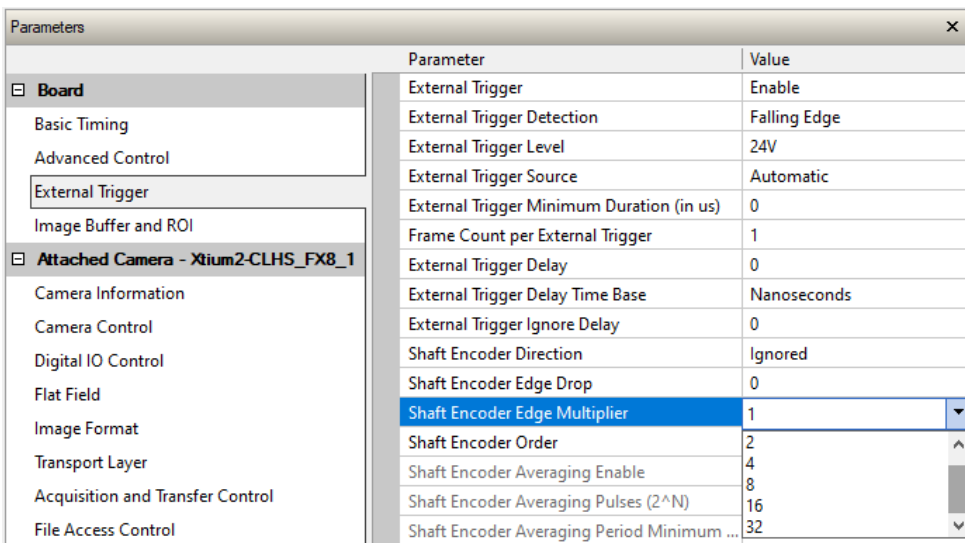

Figure 66: CamExpert Shaft Encoder Edge Multiplier Feature

The Shaft Encoder Edge Drop values can range from 0 - 254.

NOTE

Remember to enter the object pixel size using the Encoder Resolution feature if it deviates from 84 µm (300 dpi), 56 µm (450 dpi), 42 µm (600 dpi) or 28 µm (900 dpi).

For more details on adjusting the shaft encoder refer to the Application Note for Multiplier Divider available from the Teledyne DALSA website at [App Notes | Teledyne DALSA](#).

Changing Scan Direction

Some inspection systems require that the scan direction change at regular intervals. For example, scanning a panel forwards, coming to a stop and then scanning backward as the camera's field of view is progressively indexed over the entire panel.

It is necessary for the system to over-scan the area being imaged by at least 128 encoder pulses (EXSYNC) before the direction is changed. This ensures that valid data will be generated on the return path as the module's field of view reaches the area to be inspected. The direction change time between forward and reverse is < 100 ms.

Angle Correction: Imaging when not Perpendicular to the Object Surface

Related Feature: [Angle Correction](#), [Acquisition Start](#) and [Acquisition Stop](#)

To obtain optimum imaging performance, the module may need to be angled away from perpendicular to the object surface. This changes the stagger distance between the sensor images, which affects the module's alignment algorithms. AxCIS images do not suffer from parallax issues when the module is at an angle, as with standard camera/lens configurations, due to the optical properties of the SLA.

Alignment can be restored by using the Angle Correction feature to specify the module's angle away from perpendicular; the module adjusts the alignment parameters accordingly to ensure an aligned image.

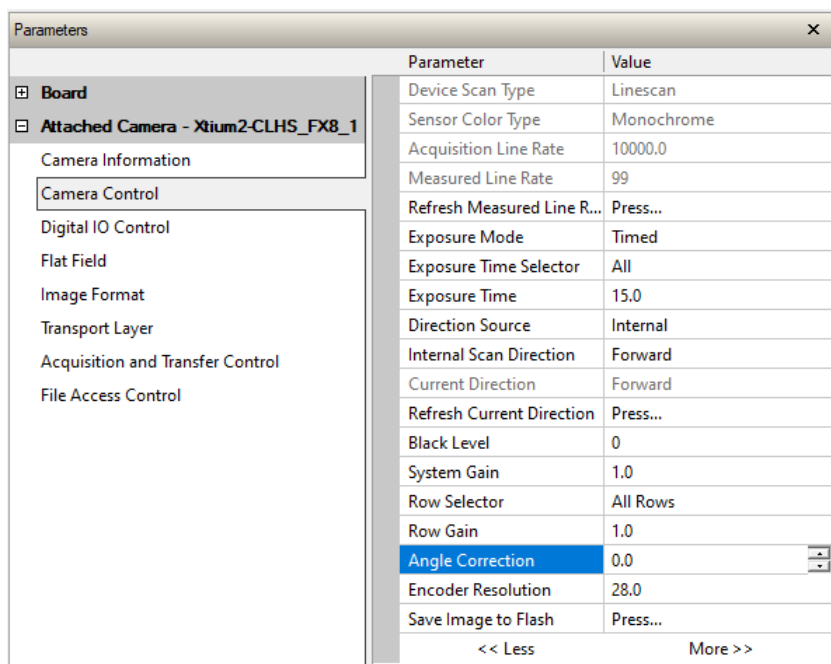

Figure 67: CamExpert Angle Correction Feature

The adjustment is not sensitive to whether the angle is positive or negative. Large angle correction (>30°) may result in MTF degradation therefore image quality should be evaluated. .

NOTE

Acquisition must be stopped to access the [Angle Correction](#) feature; use the [Acquisition Stop](#) feature to do so. The default object pixel value is 84 µm (300 dpi), 56 µm (450 dpi), 42 µm (600 dpi) or 28 µm (900 dpi); only larger object pixel sizes can be entered. Use the [Acquisition Start](#) feature to restart acquisition.

Imaging with Non-Square Object Pixels

Related Features: [Encoder Resolution](#), [Acquisition Start](#) and [Acquisition Stop](#)

In some applications the speed of the object and/or the available light may force the use of an object pixel size greater than 84 µm (300 dpi), 56 µm (450 dpi), 42 µm (600 dpi) or 28 µm (900 dpi). For example, if the inspection system is using a larger pixel to accommodate a faster web speed or achieve a longer integration time.

Since the *maximum web speed* = *maximum line rate* x [encoder resolution](#) (object pixel size), the larger pixel size allows for longer integration times.

Use the [Encoder Resolution](#) feature, available in the Camera Control category, to enter the object pixel size.

NOTE

Acquisition must be stopped to access the [Encoder Resolution](#) feature; use the [Acquisition Stop](#) feature to do so. The default object pixel value is 84 µm (300 dpi), 56 µm (450 dpi), 42 µm (600 dpi) or 28 µm (900 dpi); only larger object pixel sizes can be entered.

The screenshot shows the CamExpert software interface. On the left, a tree view under 'Attached Camera - Xtium2-CLHS_FX8_1' has 'Camera Control' selected. The main panel displays a list of camera parameters. The 'Encoder Resolution' parameter is highlighted in blue and set to 28.0. Below the list, the feature's metadata is shown:

Exposure Time Selector	All
Exposure Time	6.0
Direction Source	Internal
Internal Scan Direction	Reverse
Current Direction	Reverse
Refresh Current Direction	Press...
Black Level	0
System Gain	2.0
Row Selector	All Rows
Row Gain	1.0
Sensor Selector	0
Sensor Gain	1.0
Response Levelling Trigger	Press...
Angle Correction	0.0
Encoder Resolution	28.0
Vertical Offset	0.0

Feature Display Name: Encoder Resolution
Description: The distance traveled by the object for each encoder pulse.
Feature Name: encoderResolution
Type: IFloat (SapFeature::TypeDouble)

Values:
Min: 28
Max: 200
Inc: 0.1

Figure 68: CamExpert Encoder Resolution Feature

Using Area of Interest (AOIs)

Reduce Image Data & Enhance Performance

See the section Image Format Category and Acquisition and Transfer Control Category in Appendix A for GenICam features associated with this section and how to use them

Related Features: [AOI Count](#), [AOI Selector](#), [AOI Offset](#), [AOI Width](#), [AcquisitionStart](#), [AcquisitionStop](#) and [AcquisitionStatus](#)

If the module's field of view includes areas that are not needed for inspection (also refer to the [Flat Field Calibration Region of Interest](#) section) then the user may want to ignore this unwanted image data.

Eliminating unwanted image data reduces the amount of information the host computer needs to process. When using 12-bit output data, this can increase the maximum allowable line rate due to CLHS bandwidth limits.

A module section can accommodate up to four AOIs. Image data outside the AOIs is discarded. Each AOI is user selected and its pixel boundaries defined. The module assembles the individual AOI's into one contiguous image line with a width equal to the sum of the individual AOIs.

The frame grabber needs to be adjusted to accommodate the smaller overall image width. As the host computer defines the size of each individual AOI, it can extract and process each individual AOI from the single larger image.

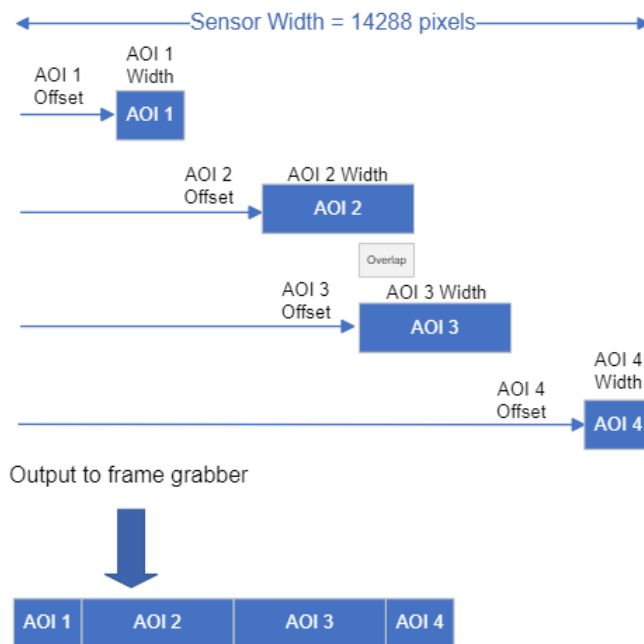

Figure 69: AOI Output to Frame Grabber

NOTE

Each module section is effectively a separate CLHS connection with its own controls, four AOIs are available for each module. That is, a 400 mm model has one module and a 700 or 800 mm model has two modules.

Rules for Setting Areas of Interest

The rules are dictated by how image data is organized for transmission over the available CLHS data lanes. The camera enforces these rules, truncating entered values where necessary.

Table 18: AOI Specifications

Module Resolution	Number AOIs per Module	Step Size	Minimum AOI Width	Maximum AOI Width (pixels)	AOI Offset (pixels)
300	0 - 4	16 pixels	48 pixels (sum of all AOIs >= 512 pixels)	4768	0-4720
450				7152	0-7104
600 dpi		32 pixels	96 pixels (sum of all AOIs >= 1024 pixels)	9536	0 - 9440
900 dpi				14304	0- 14208

- Up to 4 AOIs can be specified using the step size and minimum widths for the selected dpi, respecting the minimum total of all AOI widths summed together.
- Overlapping AOIs are allowed.
- AOIs are concatenated together in numerical order and sent to the frame grabber starting at column zero. If the AOI count is reduced to less than the current AOI count, the AOI selector will be changed to the largest of the new AOI count available.
- Maximum 8 kB per CLHS lane.
- Offset and width for individual AOI's will "push" one another.
- AOI's only affect one another by limiting the maximum width.
For example, in a 400 mm module, if an AOI has offset 0, width 9536, and the offset is changed to 4096, then the width will be "pushed" to 5440.

NOTE

AOI parameters can only be changed when image transfer to the frame grabber is stopped. Refer to the Acquisition and Transfer Control Category in the appendix for details on stopping and starting the acquisition.

Steps to Setup Area of Interest for Each Module Section

1. Plan your AOIs.
2. Stop acquisition, using the *Acquisition Stop* feature. In CamExpert this feature is available in the Acquisition and Transfer Control category:

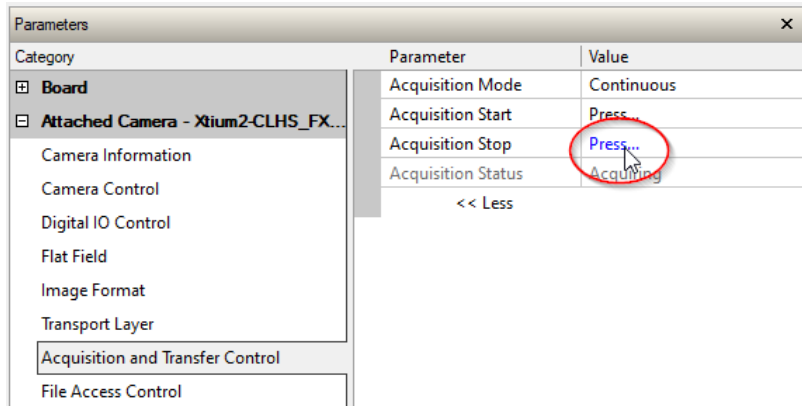

Figure 70: CamExpert Acquisition Stop Feature

The *Acquisition Status* feature displays the current status as *Acquiring* or *Not Acquiring*.

3. Set the number of AOIs using the AOI Count Horizontal (*multipleROICount*) feature.
4. In CamExpert, AOI related features are available in the Image Format category:

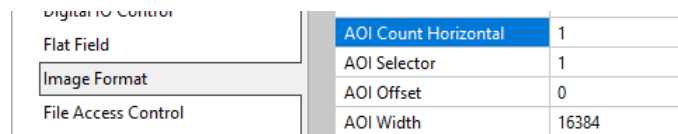

Figure 71: CamExpert AOI Features

5. Select the first AOI and set the offset and width. If the other AOIs are large you may need to select them first and reduce their widths.
6. Repeat for each AOI in turn.
7. Start acquisition, using the Acquisition Start feature.

Adjusting Responsivity and Contrast Enhancement

See the section Camera Control Category in Appendix A for GenICam features associated with this section and how to use them.

Related Features: [Row Selector](#), [System Gain](#), [Black Level](#)

It is best for module performance to always use the maximum exposure time possible based on the maximum line rate of the inspection system and any margin that may be required to accommodate illumination degradation. However, it will be necessary to adjust the responsivity to achieve the desired output level from the module. The module has row gain and black level (offset) features that can be used to adjust the module's responsivity.

Gain and black level settings are applied as follows:

$$DN_{out} = ((DN_{in} + \text{Black Level}) * \text{Row Gain}) * \text{System Gain}$$

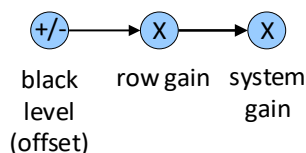

Figure 72: Black Level, Row Gain and System Gain Processing Chain

Row gain adjustment can be applied to all sensor array output rows or selectively each row; if the *Exposure Mode* feature is set to *Timed*, only one row is available. In Dual exposure mode, two rows are available where each can have a separate row gain value. Row gains can be adjusted from 1 to 4.99x. The *System Gain* feature can be adjusted from 1 to 7.99x.

When an image contains no useful dark image data below a specific threshold, then it may be beneficial to increase the contrast of the image.

Black Level

The module has a black level (offset) feature that allows a specified level to be added or subtracted from the image data.

Negative values can be used to eliminate dark areas of no interest. The gain feature can then be used to return the peak image data to near output saturation with the result being increased image contrast. First, determine the offset value to subtract from the image with the current gain setting. Then set this as a negative offset value and apply additional gain to achieve the desired peak image data values.

Positive values can be used to eliminate black clipping of image data. This can be useful when measuring dark noise performance.

Adjusting Individual Pixels

See the section Flat Field Category in Appendix A for GenICam features associated with this section and how to use them.

Related Features: Multiply Pixel PRNU Pixel, Multiply Pixel PRNU Value, Multiply Pixel PRNU

If the module window gets contaminated by a particle, it may alter the responsivity of pixels in that location. Access to cleaning or executing a flat field calibration may not be feasible on an active production line and therefore an alternative means to correct the responsivity of those pixels is required.

These features select the pixel, set a gain value, and then apply it where the current PRNU coefficient for that pixel will be multiplied by the value.

If the results are acceptable, the modified PRNU set can be saved.

If the result was not acceptable, the inverse can be applied: for example, if 1.1 was applied and needs to be undone, then multiply by $1 / 1.1 = 0.91$

The valid multiplier value range is 0.5 to 2.

NOTE

To enable the Multiply Pixel PRNU Pixel, Multiply Pixel PRNU Value, Multiply Pixel PRNU features the AOI Count must be set to 1 and the AOI Width must be set to the maximum image width of 14304.

AOI parameters can only be changed when image transfer to the frame grabber is stopped. Refer to the Acquisition and Transfer Control Category in the appendix for details on stopping and starting the acquisition.

Response Leveling

Analog circuitry, as present in all types of sensors and associated analog to digital converters, may have a tendency to change their characteristics over temperature. This could cause a small change in the response from sensor to sensor. Sensor to sensor response leveling can be automatically performed by the module.

Related Features: [Response Levelling Trigger](#), [Response Levelling Offset X](#), [Response Levelling AOI Width](#)

Response leveling can be performed while imaging, however, when leveling is applied, a small disturbance in the image may occur. The user can initiate when this occurs using the response leveling trigger. The object being imaged must be moving when Response Leveling is performed. The faster the motion, the quicker it completes as it involves averaging multiple lines.

To perform this in CamExpert, click the [Response Levelling Trigger](#) field, available in the Camera Control category.

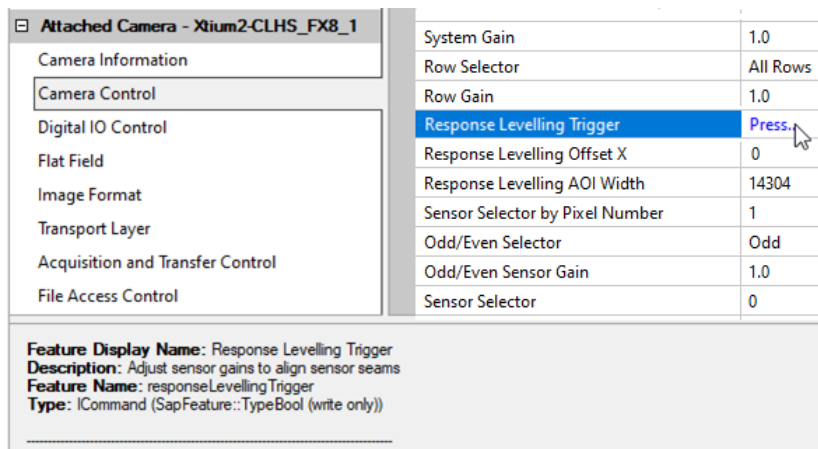

Figure 73: CamExpert Response Levelling Trigger Feature

For the response leveling trigger to be effective, the following considerations must be taken into account:

- Correction is limited to pixels within the 50-220 DN range. Response levelling can be performed on an AOI within the image by setting the [Response Levelling Offset X](#) and [Response Levelling AOI Width](#).
- Only activate the Response Levelling Trigger when the inspection target is within the field of view.
- Response leveling will not be effective if the image is not aligned and there are vertical stagger issues. Any out-of-focus or Exsync synchronization issues causing vertical stagger must be resolved first for response leveling to be effective.

NOTE

To be effective, there should be no saturated pixels and reasonably bright image content, response leveling cannot function with a very dark image. Correction is limited to pixels within the 50-220 DN range: **If any pixels in the FOV are outside this range response leveling will not be executed.**

However, in dual exposure mode, this may occur where high dynamic range images are required. For example, the user has set a long and short integration time where the row with the long integration time may have saturated pixels. The module is capable of accommodating this scenario; however, the short integration time row should still have no saturated pixels.

Optional LED Array Control

The module can accommodate optional integrated white LED arrays, one on each side of the image line.

Related Features: [LED Selector](#), [LED Intensity](#)

The LED intensity can be adjusted from 100% down to 0% (off). The LED arrays can be adjusted independently or together as controlled by the [LED Selector](#) feature, available in the Digital IO Control category.

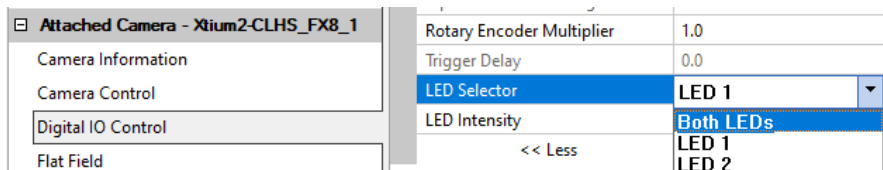

NOTE

As with all LEDs, output degrades over extended periods of use, typically by 50% over 50,000 hours. Therefore, it is recommended LED intensity is set to give some room for adjustment to accommodate this degradation.

Users can replace the LED arrays if degradation over time exceeds acceptable levels.

Customized Linearity Response (LUT)

See the section [Flat Field Category](#) for GenICam features associated with this section and how to use them.

Related Features: [lutMode](#) and [gammaCorrection](#)

The camera allows the user to access a LUT (Look Up Table) to customize the linearity of how the camera responds. This can be done by uploading a LUT to the camera using the file transfer features, or by using the Gamma Correction feature.

NOTE

These features may only be useful in applications that use the frame grabber's Mono Image Buffer Format. (See section [Changing Output Pixel Format](#).)

Gamma correction value can be adjusted by the user at any time; see section [Gamma Correction Factor](#).

When the LUT is enabled, there is no change in maximum line rate or amount of data output from the camera. The LUT can be used with any mode of the camera. Further, when the LUT is enabled, it is recommended that the fixed Offset available in the Camera Control category be set to zero.

To upload a LUT, use *File Access Control Category > Upload / Download File > Settings* and select *Look Up Table* to upload a file.

The file format is described in 03-084-20133 Linea Binary File Format which can be obtained from Teledyne DALSA Technical Support. This document also includes Excel spreadsheet examples.

How to Generate a LUT with CamExpert

CamExpert can be used to create a LUT file. The camera uses a 12-bit in/12-bit out LUT (even if the camera is outputting an 8-bit image). CamExpert can be configured to create a 12-bit in/16-bit out LUT - the camera will convert it to the required format.

To generate a LUT

1. Open CamExpert (version 8.40 or higher).
2. Under Board, set Basic Timing > Pixel Depth to 12.

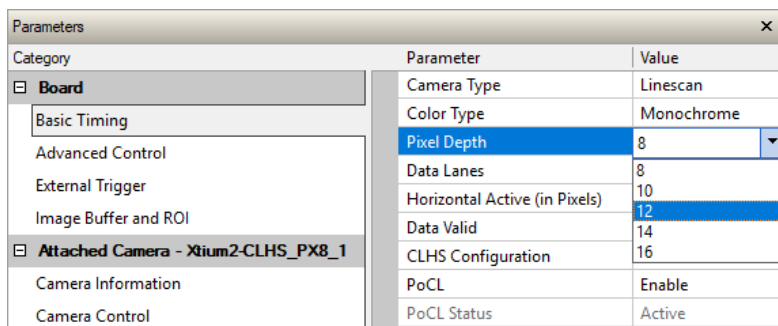

3. Under Board, set Image Buffer and ROI > Image Buffer Format to *Monochrome 16-bits*.

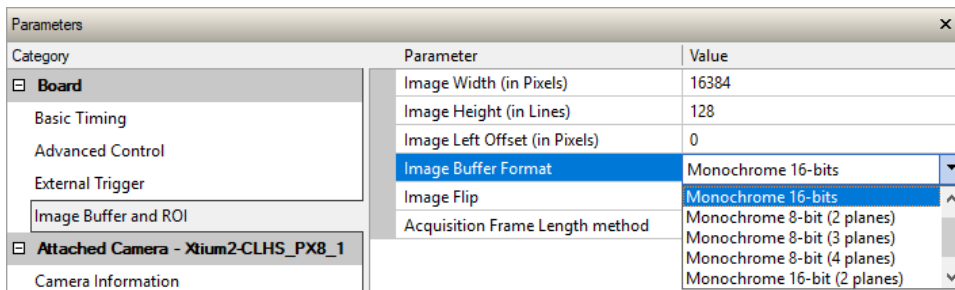

- In CamExpert's menu bar, select Pre-Processing > Lookup Table, then
 - select **Enable**
 - select **Setting**.

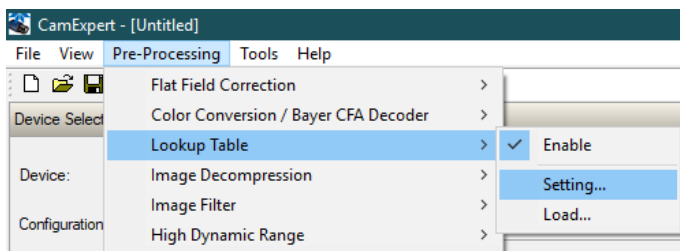

- In the Lookup Table dialog, under the **Value** column, select the output LUT by scrolling through the different options. Configure any required parameters (for example, Gamma correction requires a Correction factor).

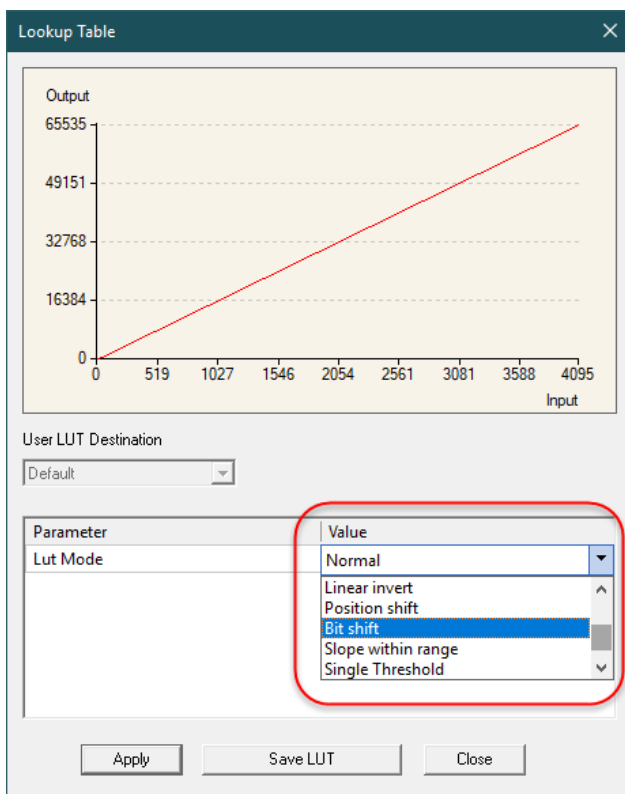

- Click **Save LUT** to create a LUT file.

7. This file can be loaded into the camera using the File Access features. It is saved with the current Load/Save Configuration user set; ensure that a user set and not the factory set is selected, otherwise the upload will fail.
8. Deselect the Lookup Table > Enable.
9. Return the Board parameters to original settings :
 - Basic Timing > Pixel Depth = 8
 - Image Buffer and ROI > Image Buffer = 8-bits.

IMPORTANT

- The frame grabber must be configured mono 12-bits in, 16-bits out.
- In the Parameters pane, a frame grabber feature must be selected, not a camera feature.
- The Lookup table must be enabled to be created but should be disabled to use the camera LUT.

Gamma Correction Factor

The following graphic shows LUT output data as a function of the gamma correction factor programmed by the user. The Gamma Correction feature is available in the Flat Field category.

Parameters		Parameter	Value
Category			
Board		Flat Field Correction Mode	On
Attached Camera - Xtium2-CLHS_FX8_1		Clear Coefficients	Press...
Camera Information		Calibration Algorithm	Set Target
Camera Control		Flat Field Calibration Target	12
Digital IO Control		Flat Field Calibration Offset X	0
Flat Field		Flat Field Calibration Width	14304
Image Format		Calibrate FPN	Press...
Transport Layer		Row Selector	All Rows
Acquisition and Transfer Control		Calibrate PRNU	Press...
File Access Control		Output LUT Mode	Gamma Correction
		Gamma Correction	1.733

Figure 74: CamExpert Gamma Correction Feature

Gamma Correction is enabled by default. An 8-bit LUT is shown as an example and importantly the graphic is not to scale.

- As Gamma Correction is reduced in value to the minimum allowed, the nonlinear output of acquisition data through the LUT effectively boosts low value data.
- As Gamma Correction is increased in value to the maximum allowed, the nonlinear output of acquisition data through the LUT effectively reduces low value data.

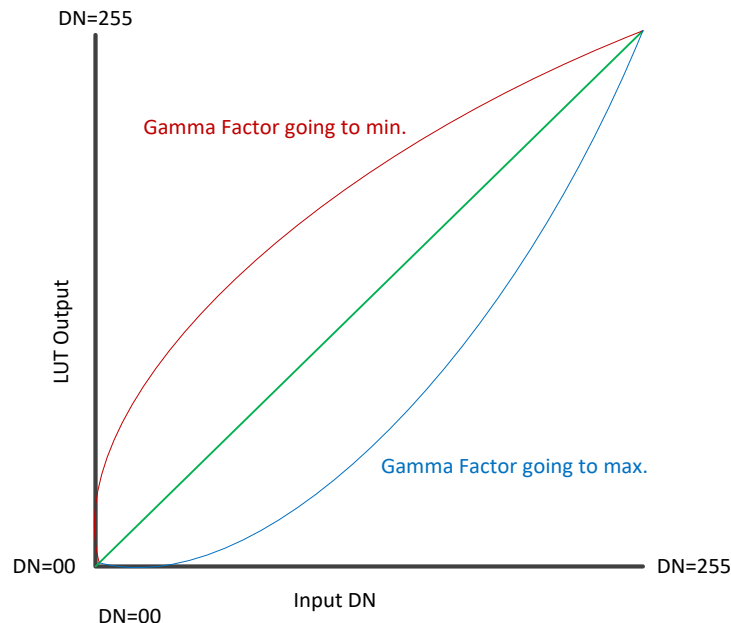

Figure 75: Gamma Correction 8-bit LUT Example

Saving & Restoring Camera Setup Configurations

See the [Camera Information Category](#) section in Appendix A for GenICam features associated with this section and how to use them.

Related Features: [UserSetSelector](#), [UserSet1 thru UserSet16](#), [UserSetDefaultSelector](#), [UserSetLoad](#), [UserSetSave](#)

An inspection system may use multiple illumination, resolution and responsivity configurations in order to cover the different types of inspection it performs. The module includes 16 user sets where module setup information can be saved to and restored from—either at power up or dynamically during inspection.

The settings active during the current operation can be saved (and thereby become the user setting) using the user set save feature.

A previously saved user setting (User Set 1 to 16) or the factory settings can be restored using the user set selector and user set load features.

Either the factory setting or one of the user settings can be selected as the default setting, by selecting the set in the user set default selector (Camera Power-up configuration option in the Power-up configuration dialog accessed from the Camera Information category). The set selected is the default setting and is the set that is loaded and becomes active when the module is reset or powered up.

The relationship between these four settings is illustrated in

Figure 76. Relationship Between Camera Settings:

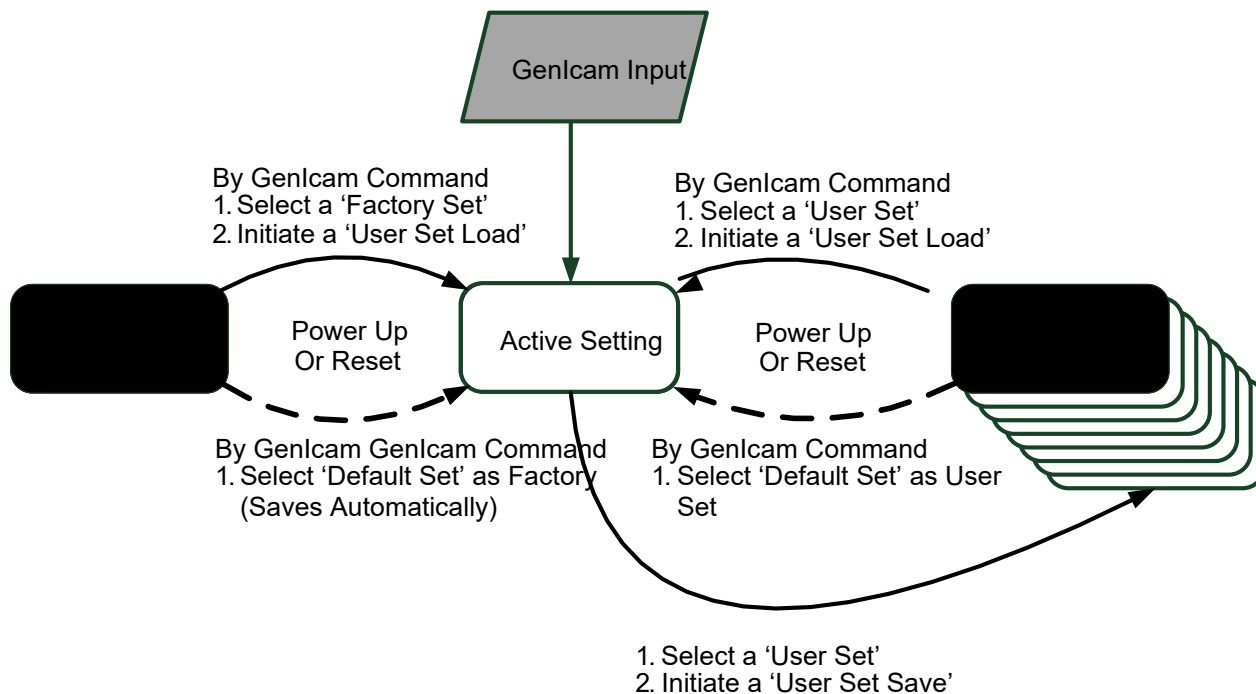

Figure 76. Relationship Between Camera Settings

Active Settings for Current Operation

Active settings are those settings used while the camera is running and include all unsaved changes made by GenICam input to the settings.

These active settings are stored in the module's *volatile* memory and will be lost and cannot be restored if the module resets, is powered down or loses power during operation.

To save these settings so that they can be restored next time you power up the modules or to protect against losing them in the case of power loss, you must save the current settings using the user set save parameter. Once saved, the current settings become the selected user set.

User Setting

The user setting is the saved set of camera configurations that you can customize, resave, and restore. By default, the user settings are shipped with the same settings as the factory set.

The command `UserSetSave` saves the current settings to non-volatile memory as a user set. The module automatically restores the user set configured as the default set when it powers up.

To restore a saved user set, set the user set selector to the set you want to restore and then select the user set load parameter.

Factory Settings

The factory setting is the modules settings that were shipped with the module and which load during the camera's first power-up. To load or restore the original factory settings, at any time, select the factory setting parameter and then select the user set load parameter.

NOTE

By default, the user settings are set to the factory settings.

Default Setting

Either the factory or one of the user settings can be used as the default setting, by selecting the set to use in the user set default selector. The chosen set automatically becomes the default setting and is the set loaded when the camera is reset or powered up.

Appendix A: GenICam Commands

This appendix lists the available GenICam camera features. The user may access these features using the CamExpert interface or equivalent GUI.

Features listed in the description table but tagged as *Invisible* are typically reserved for Teledyne DALSA Support or third-party software usage, and not typically required by end user applications.

The following feature tables describe these parameters along with their view attributes and in which version of the device the feature was introduced. Additionally, the Device Version column will indicate which parameter is a member of the DALSA Features Naming Convention (using the tag **DFNC**), versus the GenICam Standard Features Naming Convention (SFNC tag not shown).

In the CamExpert panes, parameters in gray are read only, either always or due to another parameter being disabled. Parameters in black are user set in CamExpert or programmable via an imaging application. Sopera LT includes an example program (CameraFeatures.exe) that demonstrates how to access features using the Sopera LT SDK.

The **B/W & Color** column (when present) indicates whether a feature applies to monochrome or color via a symbol. Absence of a symbol indicates a common feature.

NOTE

CamExpert examples are for illustrative purposes and may not entirely reflect the features and parameters available from the model used in your application.

Camera Information Category

Camera information can be retrieved via a controlling application. Parameters such as camera model, firmware version, etc. are read to uniquely identify the connected camera. These features are typically read-only.

The Camera Information Category groups information specific to the individual camera. In this category the number of features shown is identical whether the view is Beginner, Expert, or Guru.

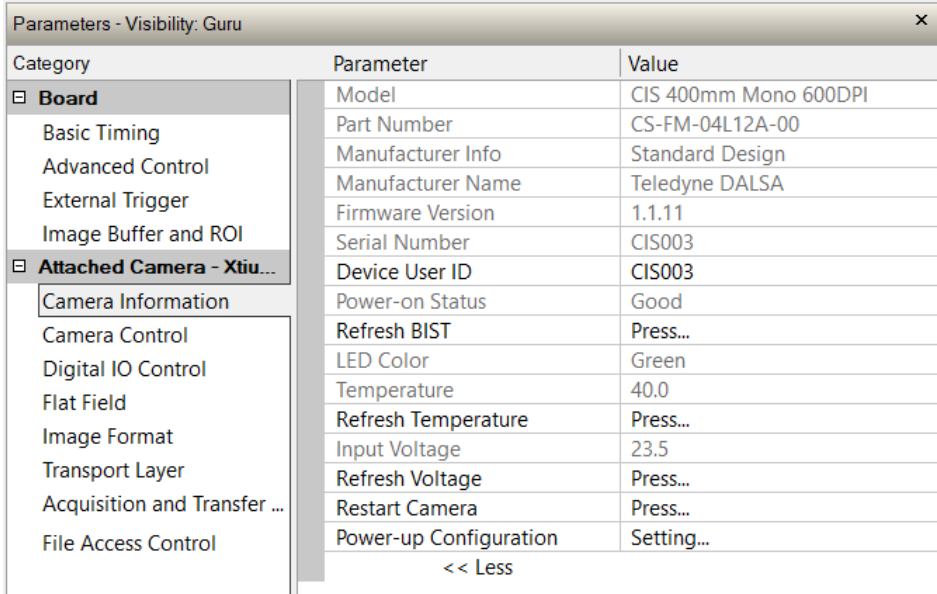

Figure 77 Example CamExpert Module Information Panel

Camera Information Feature Descriptions

Display Name	Feature	Description	View
Model	DeviceModelName	Displays the device model name. (RO)	Beginner
Part Number	deviceManufacturesPartNumber	Displays the device vendor part number. (RO)	Beginner DFNC
Manufacturer Info	DeviceManufacturerInfo	This feature provides extended manufacturer information about the device. Indicates if it is a standard product or a custom camera (RO)	Beginner
Manufacturer Name	DeviceVendorName	Displays the device vendor name. (RO)	Beginner
Firmware Version	DeviceVersion	Displays the device firmware version. This tag will also highlight if the firmware is a beta or custom design. (RO)	Beginner
Serial Number	DeviceID	Displays the device's factory set camera serial number. (RO)	Beginner
Device User ID	DeviceUserID	Feature to store user-programmable identifier of up to 31 characters. The default factory setting is the camera serial number. (RW)	Beginner
Power-on Status	deviceBISTStatus	Determine the status of the device using the 'Built-In Self Test' (BIST). Possible return values are device-specific. (RO) See Built-In Self-Test Codes for status code details.	Beginner DFNC
Refresh BIST	deviceBIST	Command to perform an internal test which will determine the device status. (W)	Beginner DFNC

Display Name	Feature	Description	View
LED Color <i>Off</i> <i>Red</i> <i>Green</i> <i>Waiting for EXSYNC</i> <i>Thermal Shutdown</i> <i>Looking for link</i> <i>Busy</i>	deviceLEDColorControl <i>Off</i> <i>Red</i> <i>Green</i> <i>Fast_Green</i> <i>Medium_Red</i> <i>Slow_Green</i> <i>Medium_Orange</i>	Select the mode of the Status LED on the back of the module <i>Off</i> <i>BIST error.</i> <i>Operational.</i> <i>4 Hz Green.</i> <i>2 Hz Red.</i> <i>1 Hz Green.</i> <i>2 Hz Orange.</i>	Beginner DFNC
Temperature	DeviceTemperature	Displays the internal operating temperature of the camera, in Celsius. (RO)	Beginner DFNC
Refresh Temperature	refreshTemperature	Press to update <i>DeviceTemperature</i> .	Beginner DFNC
Input Voltage	deviceInputVoltage	Displays the input voltage to the camera at the power connector (RO)	Beginner DFNC
Refresh Voltage	refreshVoltage	Press to update <i>deviceInputVoltage</i> .	Beginner DFNC
Restart Camera	DeviceReset	Soft reset of the module	Beginner SFNC
Power Up Configuration		Detailed in Dialog Box by initiating Settings...	
Power-on User Set <i>Factory Set</i> <i>UserSet1</i>	UserSetDefaultSelector <i>Factory</i> <i>UserSet1 to UserSet16</i>	Selects the camera configuration set to load and make active on camera power-up or reset. The camera configuration sets are stored in camera non-volatile memory. (RW) <i>Load factory default feature settings</i> <i>Select the user defined configuration set as the Power-up Configuration. 16 user sets are available.</i>	Beginner
Current User Set <i>Factory Set</i> <i>UserSet 1</i>	UserSetSelector <i>Factory</i> <i>UserSet1 to UserSet16</i>	Selects the camera configuration set to load feature settings from or save current feature settings to. Points to which user set (1-16) or factory set that is loaded or saved when the UserSetLoad or UserSetSave command is used. The Factory set contains default camera feature settings and is read-only. (RW) <i>Select the default camera feature settings saved by the factory</i> <i>Select the User-defined Configuration space to save to or load from features settings previously saved by the user. 16 user sets are available.</i>	Beginner
Load User Set	UserSetLoad	Loads the camera configuration set specified by the User Set Selector feature, to the camera and makes it active. (W)	Beginner
Save User Set	UserSetSave	Saves the current camera configuration to the user set specified by the User Set Selector feature. The user sets are located on the camera in non-volatile memory. (W)	Beginner

Built-In Self-Test Codes (BIST)

In the Camera Information screen shot example above, the Power-On Status is showing "Good", indicating that the camera powered up without any problems. Descriptions of all BIST codes are available in the [Built-In Self-Test Codes](#) section.

Power-Up Configuration Selection Dialog

CamExpert provides a dialog box which combines the GenICam features used to select the camera's power-up state and for the user to save or load a camera state as a specific user set that is retained in the camera's non-volatile memory.

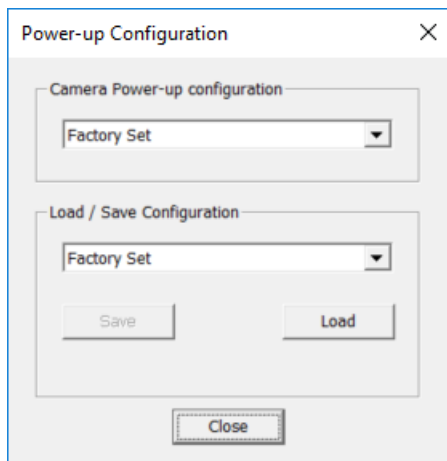

Figure 78: CamExpert Power-Up Configuration Dialog

Camera Power-up Configuration

The first drop-down list selects the camera configuration set to load on power-up (see [UserSetDefaultSelector](#) feature). The user chooses the factory data set or from one of 16 available user-saved states.

User Set Configuration Management

The second drop list allows the user to change the camera configuration any time after a power-up (see the [UserSetSelector](#) feature). To reset the camera to the factory configuration, select *Factory Set* and click Load. To save a current camera configuration, select User Set 1 to 16 and click Save. Select a saved user set and click Load to restore a saved configuration.







Camera Control Category

The camera control category, as shown by CamExpert, groups control parameters such as line rate, exposure time, scan direction, and gain.

Category	Parameter	Value
Board Basic Timing Advanced Control External Trigger Image Buffer and ROI Attached Camera - Xiu... Camera Information Camera Control Digital IO Control Flat Field Image Format Transport Layer Acquisition and Transfer C... File Access Control	Device Scan Type	Linescan
	Sensor Color Type	Color RGB
	Acquisition Line Rate	10000.0
	Measured Line Rate	32594
	Refresh Measured Line Rate	Press...
	Exposure Mode	Dual Exposure
	Exposure Time Selector	All
	Exposure Time	2.0
	Direction Source	Internal
	Internal Scan Direction	Reverse
	Current Direction	Reverse
	Refresh Current Direction	Press...
	Black Level	0
	System Gain	1.0
	Row Selector	All Rows
Row Gain	1.78418	
Response Levelling Trigger	Press...	
Response Levelling Offset X	0	
Response Levelling AOI Width	4768	
Sensor Selector by Pixel Numb...	1	
Odd/Even Sensor Selector	Odd	
Odd/Even Sensor Gain	1.0	
Sensor Selector	0	
Sensor Gain	1.0	
Vertical Offset	0.0	
Skew	0.0	
Balance White Auto	Press...	
Angle Correction	0.0	
Encoder Resolution	84.0	
Blue Crosstalk	0.0261	
Red Crosstalk	0.0449	
Sensor Seam Management	Stitched	
External Encoder Jitter Filter	Off	
Color Transformation Selector	Matrix 1	
Color Transformation Enable	Enable	
Color Transformation Value Sel...	Offset0	
Color Transformation Value	-0.01577	
Save Color Transformation	Press...	
Fast Response Levelling Trigger	Press...	
Save Image to Flash	Press...	

Figure 79: Camera Control Features

Camera Control Feature Descriptions

B/W Color	Display Name	Feature	Description	View
	Device Scan Type <i>Linescan</i>	DeviceScanType <i>Linescan</i>	Used to set the camera scanning mode. Only standard line scan mode is available. <i>Linescan sensor.</i>	Beginner
	Sensor Color Type <i>Monochrome</i>	sensorColorType <i>Monochrome</i>	Used to set the sensor color type mode. Only monochrome is available. <i>Monochrome sensor.</i>	Beginner DFNC
	<i>Color RGB</i>	<i>CFA_RGB</i>	<i>Color RGB sensor.</i>	
	Acquisition Line Rate	AcquisitionLineRate	Specifies the camera internal line rate, in Hz when Trigger mode set to internal. Note that any user entered value is automatically adjusted to a valid camera value. If necessary, the exposure time will be decreased to fit within the line time. Minimum internal line rate is 300 Hz.	Beginner
	Measured Line Rate	measuredLineRate	Specifies the line rate provided to the camera by either internal or external source. (RO)	Beginner DFNC
	Refresh Measured Line Rate	refreshMeasuredLineRate	Press to show the current line rate provided to the camera by either internal or external sources.	Beginner DFNC
	Exposure Mode	ExposureMode	Sets the type of exposure mode.	Beginner
	<i>Timed</i>	<i>Timed</i>	<i>Single row exposure mode</i>	
	<i>Dual Exposure</i>	<i>DualExposure</i>	<i>Dual row exposure mode</i>	
	Exposure Time Selector	exposureTimeSelector	Used to select which exposure time is being set.	Beginner DFNC
	<i>All</i>	<i>All</i>	<i>Default to 'ALL' in timed mode or selects both Row1 and Row 2 to set the desired exposure time.</i>	
	<i>Row 1</i>	<i>Row1</i>	<i>Selects Row 1 to set the desired exposure time.</i>	
	<i>Row 2</i>	<i>Row2</i>	<i>Selects Row 2 to set the desired exposure time.</i>	
	<i>Red / Blue</i>	<i>RedBlue</i>	<i>Selects the Red and Blue row to set the desired exposure time.</i>	
	<i>Green</i>	<i>Green</i>	<i>Selects Green row to set the desired exposure time.</i>	
	Exposure Time	ExposureTime	Sets the exposure time in µsec to the desired value. Note that any user entered value is automatically adjusted to a valid camera value. If necessary, the line rate will be decreased to match the exposure time.	Beginner
	Direction Source	sensorScanDirectionSource	Direction determined by value of:	Beginner DFNC
	<i>Internal</i>	<i>Internal</i>	<i>SensorScanDirection</i>	
	<i>Line 2</i>	<i>GPIO2</i>	<i>Pin 6 (Low: forward, high: reverse). Available when TriggerSource is not Encoder.</i>	
	Internal Scan Direction	sensorScanDirection	When <i>ScanDirectionSource</i> is set to Internal, determines the direction of the scan.	Beginner DFNC
	<i>Forward</i>	<i>Forward</i>	<i>Forward scan direction.</i>	
	<i>Reverse</i>	<i>Reverse</i>	<i>Reverse scan direction.</i>	
	Current Direction	currentDirection	Used to read what the current direction (RO).	Beginner DFNC
	Refresh Current Direction	refreshCurrentDirection	Updated the current direction to what is currently active.	Beginner DFNC
	Black Level	BlackLevel	Controls the black level as an absolute physical value. This represents a DC offset applied to the video signal, in DN (digital number) units. The value may be positive or negative.	Beginner
	System Gain	systemGain	Gain multiplier applied to all pixels.[1:7.99].	Beginner

B/W Color	Display Name	Feature	Description	View
	Row Selector	GainSelector	Used to select which gain value is being set.	Beginner DFNC
	<i>All</i>	<i>All</i>	<i>Default to 'ALL' in timed mode or selects both Row1 and Row 2 to set the desired gain.</i>	
	<i>Row 1</i>	<i>Row1</i>	<i>Selects Row 1 to set the desired gain.</i>	
	<i>Row 2</i>	<i>Row2</i>	<i>Selects Row 2 to set the desired gain.</i>	
	<i>Red</i>	<i>Red</i>	<i>Selects Red row to set the desired gain.</i>	
	<i>Green</i>	<i>Green</i>	<i>Selects Green row to set the desired gain.</i>	
	<i>Blue</i>	<i>Blue</i>	<i>Selects Blue row to set the desired gain.</i>	
	Row Gain	Gain	Sets the gain as per the gain selector setting. [1:4.99]	Beginner
	Response Levelling Trigger	responseLevellingTrigger	Initiates the response leveling process.	Guru DFNC
	Response Levelling Offset X	responseLevellingOffsetX	Specifies the horizontal offset, in pixels, for the response levelling operation.	Beginner DFNC
	Response Levelling AOI Width	responseLevellingAOIWidth	Specifies the width, in pixels, of the AOI on which to perform the response levelling operation.	Beginner DFNC
	Sensor Selector by Pixel Number	SensorSelectByPixel	Determines the Sensor Selector value by entering a pixel number. For example, entering the pixel value 5896 automatically sets the Sensor Selector feature to 7.	Guru DFNC
	Odd/Even Selector	sensorOddEvenSelect	Selects which set of sensors to apply the odd or even gain to.	Guru DFNC
	<i>Odd</i>	<i>Odd</i>	<i>Gain is applied to all odd numbered sensors.</i>	
	<i>Even</i>	<i>Even</i>	<i>Gain is applied to all even numbered sensors.</i>	
	Odd/Even Sensor Gain	sensorOddEvenGain	Gain multiplier applied to all odd or even sensors.	Guru DFNC
	Sensor Selector	gainSensorSelector	Selects which sensor gain is set within the module. Set "0" for all sensors. Each sensor covers 298 (300 dpi), 447 (450 dpi), 595 (600 dpi) and adjacent pixels 893 (900 dpi).	Guru DFNC
	Sensor Gain	sensorGain	Sets the sensor gain for the selected sensor.	Guru DFNC
	Vertical Offset	sensorVerticalOffset	Vertical offset applied to selected sensor for current direction, in pixels. Vertical offset can only be applied to individual sensors (that is, it cannot be applied globally to all sensors and is disabled when Sensor Selector = 0).	Guru DFNC
	Vertical Offset Reset	sensorVerticalOffsetReset	Resets any vertical offsets applied to sensors to zero for current direction.	Guru DFNC
	Skew	sensorSkew	Skew applied to each sensor. Value is different in each direction.	Guru DFNC
	Balance White Auto	BalanceWhiteAuto	Click <i>Press</i> to perform an automatic white balancing operation. This adjusts color gains such that the average of each color is the same as the average of the brightest color.	Beginner
	Blue Crosstalk	blueCrosstalk	Corrects crosstalk effect of blue in green channel.	Beginner
	Red Crosstalk	redCrosstalk	Corrects crosstalk effect of red in green channel.	Beginner
	Angle Correction	angleCorrection	Specifies the module angle to the optical axis.	Beginner DFNC
	Encoder Resolution	encoderResolution	Specifies the object pixel size. That is, the distance traveled by the object for each encoder pulse.	Beginner DFNC
	Sensor Seam Management	overlapCorrection	Selects the method to use for smoothing the seams between sensors.	Guru DFNC
	<i>Off</i>		<i>Overlap correction off.</i>	
	<i>Stitched</i>	<i>Overlap</i>	<i>Sensors are stitched together with no other corrections</i>	
	<i>Blended</i>	<i>Weighted</i>	<i>Sensors are stitched together and seams are blended</i>	

B/W Color	Display Name	Feature	Description	View
	External Encoder Jitter Filter	ExSyncSmoothing	Enable this feature if you are seeing artifacts when using an external trigger with excessive jitter. It will average the ex sync pulses to provide consistency to the trigger	Guru
	Color Transformation Selector	ColorTransformationSelector	Selects the color transformation matrix to enable or adjust.	Expert
	<i>No Correction</i>	<i>NoCorrectionMatrix</i>	<i>No color transformation is applied.</i>	
	<i>Matrix 1</i>	<i>Matrix1</i>	<i>Color transformation matrix 1 is selected.</i>	
	<i>Matrix 2</i>	<i>Matrix2</i>	<i>Color transformation matrix 2 is selected.</i>	
	<i>Matrix 3</i>	<i>Matrix3</i>	<i>Color transformation matrix 3 is selected.</i>	
	Color Transformation Enable	ColorTransformationEnable	Sets the enable state for color correction using the currently selected color transformation matrix.	Beginner
	<i>Enable</i>	<i>True</i>	<i>Color transformation is enabled.</i>	
	<i>Disable</i>	<i>False</i>	<i>Color transformation is disabled.</i>	
	Color Transformation Value Selector	ColorTransformationValueSelector	Selects the Gain factor or Offset of the Transformation matrix to access in the selected Color Transformation module.	Expert
	<i>Offset0</i>	<i>Offset0</i>	<i>Red offset.</i>	
	<i>Gain00</i>	<i>Gain00</i>	<i>Red-Red gain.</i>	
	<i>Gain01</i>	<i>Gain01</i>	<i>Red-Green gain.</i>	
	<i>Gain02</i>	<i>Gain02</i>	<i>Red-Blue gain.</i>	
	<i>Offset1</i>	<i>Offset1</i>	<i>Green offset.</i>	
	<i>Gain10</i>	<i>Gain10</i>	<i>Green-Red gain.</i>	
	<i>Gain11</i>	<i>Gain11</i>	<i>Green-Green gain.</i>	
	<i>Gain12</i>	<i>Gain12</i>	<i>Green-Blue gain.</i>	
	<i>Offset2</i>	<i>Offset2</i>	<i>Blue offset.</i>	
	<i>Gain00</i>	<i>Gain00</i>	<i>Blue-Red gain.</i>	
	<i>Gain01</i>	<i>Gain01</i>	<i>Blue-Green gain.</i>	
	<i>Gain02</i>	<i>Gain02</i>	<i>Blue-Blue gain.</i>	
	Color Transformation Value	ColorTransformationValue	Represents the value of the selected element (Gain or Offset coefficient) inside the transformation matrix.	Beginner
	Save Color Transformation	colorTransformationSave	Saves the current color transformation matrix.	Beginner DFNC
	Fast Response Levelling Trigger	previousResponseLevellingTrigger	Adjust sensor gains to align sensor seams, using the algorithm from firmware before version 81.	Guru DFNC
	Save Image to Flash	saveLastImageToFlash	Captures the current line and saves it to the cameras Flash memory as a TIFF file that can be retrieved using the File Access Control Features. <i>Can be used to compare the saved and transmitted image line data to help with debugging, if necessary.</i>	Beginner DFNC

Digital IO Control Category

The camera's Digital IO Control category is used to configure the camera's GPIO pins and LED lights.

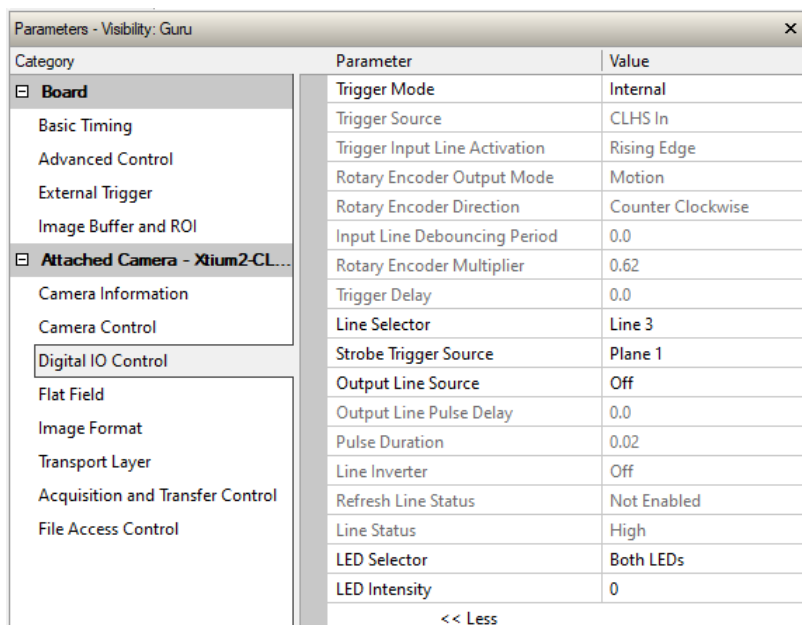

Figure 80 Digital I/O Control Panel

Digital IO Control Feature Descriptions

Display Name	Feature	Description	View
Trigger Mode	TriggerMode	Determines the source of trigger to the camera.	Beginner
<i>Internal</i>	<i>Internal</i>	<i>Line rate is controlled with AcquisitionLineRate feature.</i>	
<i>External</i>	<i>External</i>	<i>Trigger comes from CLHS (frame grabber) or GPIO.</i>	
Trigger Source	TriggerSource	Determines the source of external trigger.	Beginner
<i>CLHS In</i>	<i>CLHS</i>	<i>Source of trigger is from the frame grabber over CLHS.</i>	
<i>Rotary Encoder</i>	<i>Encoder</i>	<i>Trigger source is from the two shaft encoder inputs.</i>	
<i>Line 1</i>	<i>GPIO1</i>	<i>Trigger source is from Line 1 of the GPIO connector.</i>	
Trigger Input Line Activation	TriggerActivation	Determines which edge of a input trigger will activate on	Beginner
<i>Rising Edge</i>	<i>RisingEdge</i>	<i>The trigger is considered valid on the rising edge of the line source signal (after any processing by the line inverter module).</i>	
<i>Falling Edge</i>	<i>FallingEdge</i>	<i>The trigger is considered valid on the falling edge.</i>	
<i>Any Edge</i>	<i>AnyEdge</i>	<i>The trigger is considered valid on any edge.</i>	
Rotary Encoder Output Mode	rotaryEncoderOutputMode	Specifies the conditions for the Rotary Encoder interface to generate a valid Encoder output signal.	Beginner DFNC
<i>Position</i>	<i>Position</i>	<i>Triggers are generated at all new position increments in the selected direction. If the encoder reverses no trigger events are generated until it has again passed the position where the reversal started.</i>	
<i>Motion</i>	<i>Motion</i>	<i>The triggers are generated for all motion increments in either direction.</i>	

Display Name	Feature	Description	View
Rotary Encoder Direction	rotaryEncoderDirection	Specifies the phase which defines the encoder forward direction. This feature is used when the Rotary Encoder Output Mode is set to <i>Position</i> .	Beginner DFNC
<i>Counter Clockwise</i>	<i>CounterClockwise</i>	<i>Inspection goes forward when the rotary encoder direction is counter clockwise (phase A is ahead of phase B).</i>	
<i>Clockwise</i>	<i>Clockwise</i>	<i>Inspection goes forward when the rotary encoder direction is clockwise (phase B is ahead of phase A).</i>	
Input Line Debouncing Period	lineDebouncingPeriod	Specifies the minimum delay before an input line voltage transition is recognizing as a signal transition.	Beginner DFNC
Rotary Encoder Multiplier	rotaryEncoderFractionalMultiplier	Specifies a multiplication factor for the rotary encoder output pulse generator.	Beginner DFNC
Trigger Delay	TriggerDelay	Specifies the delay in microseconds (μ s) to apply after the trigger reception before activating it.	Beginner
Line Selector	LineSelector	Selects a GPIO output line to configure.	Beginner
Strobe Trigger Source	StrobeTrigger	Selects the plane to output on the selected GPO.	Guru
<i>Plane 1</i>	<i>Plane 1</i>	<i>Plane 1.</i>	
<i>Plane 2</i>	<i>Plane 2</i>	<i>Plane 2.</i>	
<i>Both</i>	<i>Both</i>	<i>Both plane 1 and 2.</i>	
Output Line Source	outputLineSource	GPIO 3-6 outputs controlled.	Beginner DFNC
<i>Off</i>	<i>Off</i>	<i>Line output not controlled.</i>	
<i>On</i>	<i>On</i>	<i>Line output controlled</i>	
Output Line Pulse Delay	outputLinePulseDelay	Sets the delay (μ s) before the output line pulse duration signal.	Beginner DFNC
Pulse Duration	outputLinePulseDuration	Sets the width (duration) of the output line pulse in microseconds (μ s).	Beginner DFNC
Line Inverter	LineInverter	Controls whether to invert the polarity of the selected input or output line signal.	Beginner
<i>Off</i>	<i>Off</i>	<i>Leave signal unchanged.</i>	
<i>On</i>	<i>On</i>	<i>Invert line signal.</i>	
Refresh Line Status	refreshLineStatus	Refresh Line Status feature.	Beginner DFNC
Line Status	LineStatus	Returns the current state of the selected input line.	Expert
<i>Low</i>	<i>Low</i>	<i>Line is low.</i>	
<i>High</i>	<i>High</i>	<i>Line is high.</i>	
LED Selector	ledSelector	Specified which LED array intensity is adjusted	Beginner DFNC
<i>Both LEDs</i>	<i>Both</i>	<i>Both LED's are adjusted to the desired intensity.</i>	
<i>LED 1</i>	<i>led1</i>	<i>LED1 is adjusted to the desired intensity.</i>	
<i>LED 2</i>	<i>led2</i>	<i>LED2 is adjusted to the desired intensity.</i>	
LED Intensity	ledIntensity	Specifies the selected LED intensity. Ranges from 0 (off) to 100.	Beginner DFNC

Flat Field Category

The Flat Field controls, as shown by CamExpert, group parameters used to control the FPN and PRNU calibration process.

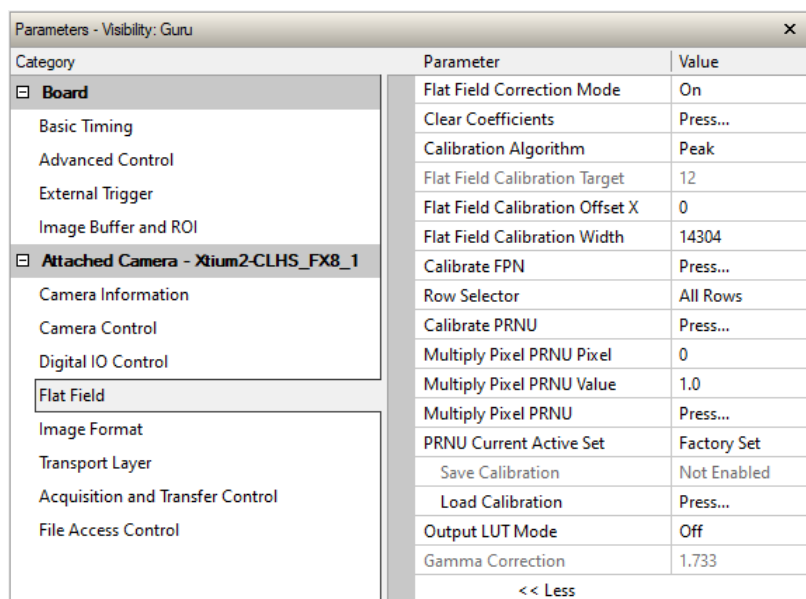

Figure 81: Flat Field Panel

Flat Field Control Feature Description

Display Name	Feature	Description	View
Flat Field Correction Mode <i>Off</i> <i>On</i>	flatfieldCorrectionMode <i>Off</i> <i>On</i>	<i>FPN and PRNU correction disabled.</i> <i>FPN and PRNU correction enabled.</i>	Beginner DFNC
Clear Coefficients	flatfieldCalibrationClearCoefficient	Reset all FPN to 0 and all PRNU coefficients to 1.	Beginner DFNC
Calibration Algorithm <i>Peak</i> <i>Target</i>	flatfieldCorrectionAlgorithm <i>Peak</i> <i>Target</i>	Selection between two different PRNU algorithms. <i>Calculation of PRNU coefficients to bring all pixels to the peak.</i> <i>Calculation of PRNU coefficients based on target (bring all pixels to target value).</i>	Beginner DFNC
Flat Field Calibration Target	flatfieldCalibrationTarget	Sets the target value for the "Calibrate PRNU" feature.	Beginner DFNC
Flat Field Calibration Offset X	flatfieldCalibrationROIOffsetX	Set the starting point of a region of interest where a flat field calibration will be performed.	Beginner DFNC
Flat Field Calibration Width	flatfieldCalibrationROIWidth	Sets the width of the region of interest where a flat field calibration will be performed.	Beginner DFNC
Calibrate FPN	flatfieldCalibrationFPN	Initiates the FPN calibration process.	Beginner DFNC
Row Selector	flatfieldCalibrationColorSelector	Specify which sensor rows to perform PRNU calibration on, all or individual colors.	Beginner DFNC
Calibrate PRNU	flatfieldCalibrationPRNU	Initiates the PRNU calibration process.	Beginner DFNC
Multiply Pixel PRNU Pixel	flatfieldMultiplyPixelPRNUSelector	Selects the pixel location to modify.	Guru DFNC
Multiply Pixel PRNU Value,	flatfieldMultiplyPixelPRNUValue	The multiplier value to adjust the pixel PRNU correction value.	Guru DFNC
Multiply Pixel PRNU	flatfieldMultiplyPixelPRNU	Initiates the correction of the pixels PRNU value.	Guru DFNC

Display Name	Feature	Description	View
PRNU Current Active Set <i>Factory Set</i> <i>User Set 1 (1 thru 16)</i>	flatfieldCorrectionCurrentActiveSet <i>Factory Set</i> <i>UserSet1 (1 thru 16)</i>	Selects the User PRNU set to be saved or loaded. <i>Factory set can only be loaded.</i> <i>Only the PRNU values are saved or loaded which is much faster than saving or loading the full Factory or User set.</i>	Guru DFNC
Save Calibration	flatfieldCalibrationSave	Saves the User PRNU set specified by <i>flatfieldCorrectionCurrentActiveSet</i> to the camera.	Guru DFNC
Load Calibration	flatfieldCalibrationLoad	Loads the User PRNU set specified by <i>flatfieldCorrectionCurrentActiveSet</i> to the camera and makes it active.	Guru DFNC
Output LUT Mode	lutMode	Sets the mode of the Output LUT.	
<i>Off</i>	<i>Off</i>	<i>Output LUT is disabled.</i>	
<i>Gamma Correcton</i>	<i>Gamma</i>	<i>Output LUT uses gamma correction.</i>	
<i>User Defined</i>	<i>UserDefined</i>	<i>Output LUT defined by user file.</i>	
Gamma Correction	gammaCorrection	Sets the gamma correction factor (that is, inverse gamma). The gamma correction factor is applied as an exponent of the original pixel value.	

Image Format Category

The camera's Image Format controls, as shown by CamExpert, group parameters used to configure camera pixel format, image cropping and test pattern generation features.

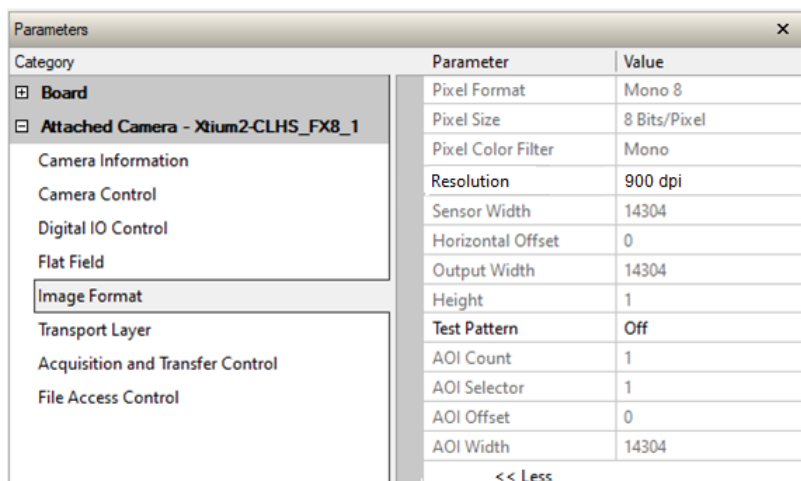





Figure 82: Image Format Panel

Image Format Feature Description

B/W Color	Display Name	Feature	Description	View
	Pixel Format <i>Mono8</i> <i>Mono12</i>	PixelFormat <i>Mono8</i> <i>Mono12</i>	Output image pixel coding format of the sensor. <i>Available bit depths for monochrome. Lower bit depths allow for higher line rates.</i>	Beginner
	<i>RGB 8</i> <i>RGB 12</i>	<i>RGB8_Planar</i> <i>RGB12_Planar</i>	<i>Available bit depths for color. Lower bit depths allow for higher line rates.</i>	
	Pixel Size <i>8-Bits/Pixel</i> <i>12-Bits/Pixel</i>	PixelSize <i>Bpp8</i> <i>Bpp12</i>	Total size in bits of an image pixel. Read-only. <i>8-Bits / Pixel.</i> <i>12-Bits / Pixel.</i>	Guru
	Pixel Color Filter <i>Mono</i>	PixelColorFilter <i>None</i>	Indicates the type of color filter used in the camera. Read only. <i>No pixel color filter when pixel format is Monochrome.</i>	Beginner
	<i>Color RB-GRB</i>	<i>RGB_RB_GRB</i>	<i>Pixel color filter is RB-GRB</i>	
	Resolution 300 DPI 450 DPI 600 DPI 900 DPI	Resolution DPI_300 DPI_450 DPI_600 DPI_900	Sets the module resolution, in dpi. 300 dpi. 450 dpi. 600 dpi. 900 dpi.	Beginner
	Horizontal Offset	OffsetX	Output image horizontal offset from the origin. This is zero for color cameras. Read only	Beginner
	Output Width	Width	Horizontal width of the pixels output. Read only	Beginner
	Height	Height	Height of the image provided by the device (in object pixels). Read only.	Beginner

Test Pattern	TestImageSelector	<p>Selects the type of test image that is sent by the camera. For more information on using test patterns, refer to the Test Patterns – What Can They Indicate? section.</p> <p>Note. Grey images are displayed so that any bit error will immediately be apparent as a color.</p> <p><i>Selects sensor video to be output</i></p> <p><i>Selects a grey scale value that is increased every 512 pixels.</i></p> <p><i>Selects a grey scale ramp.</i></p> <p><i>Selects a grey scale ramp progressively for each row.</i></p> <p><i>Selects a combination of horizontal and vertical raps to form a diagonal grey scale.</i></p>	Beginner
<p><i>Off</i></p> <p><i>Each Tap Fixed</i></p> <p><i>Grey Horizontal Ramp</i></p> <p><i>Grey Vertical Ramp</i></p> <p><i>Grey Diagonal Ramp</i></p>	<p><i>Off</i></p> <p><i>EachTapFixed</i></p> <p><i>Grey Horizontal Ramp</i></p> <p><i>Grey Vertical Ramp</i></p> <p><i>Grey Diagonal Ramp</i></p>		
AOI Count	multipleROICount	Specifies the number of AOIs output.	Beginner DFNC
AOI Selector	multipleROISelector	Select the AOI to control when setting the AOI Offset and AOI Width.	Beginner DFNC
AOI Offset	multipleROIOffsetX	Location of the start of the AOI to be output. Multiple of 32.	Beginner DFNC
AOI Width	multipleROIWidth	<p>Width of the AOI, in pixels. Minimum is 96 per lane.</p> <p>For example, if there is only one AOI spread across the 5 lanes then the minimum is $5 \times 96 = 480$.</p> <p>Maximum of the sum of AOI width's is the sensor width. For example, for a 9536 pixel module, if there are two AOIs with the first 6,144 pixels wide, then the second can be no wider than 3392 pixels.</p>	Beginner DFNC

Transport Layer Category

The Transport Layer category, as shown by CamExpert, groups features related to the CLHS connection.

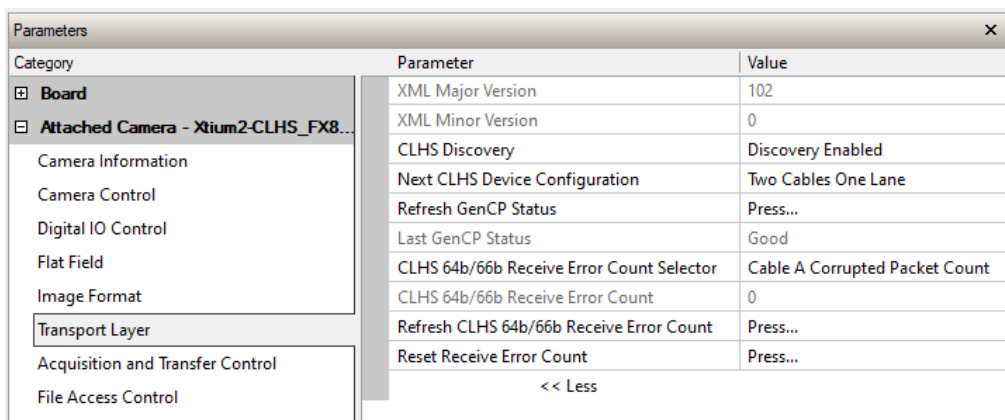

Figure 83: Transport Layer Panel

Transport Layer Feature Descriptions

Display Name	Feature	Description	View
XML Major Version	DeviceManifestXMLMajorVersion	Together with DeviceManifestXMLMinorVersion specifies the GenICam™ feature description XML file version. (RO)	Beginner
XML Minor Version	DeviceManifestXMLMinorVersion	Together with DeviceManifestXMLMajorVersion specifies the GenICam™ feature description XML file version. (RO)	Beginner
CLHS Discovery	clhsDiscovery	Selects whether the camera needs to be commanded to send image data after power up. Disable CLHS Discovery if not implemented in the frame grabber. <i>CLHS transmitters are enabled immediately on power up.</i> <i>CLHS transmitters are enabled after sending Acquisition start.</i>	Beginner DFNC
<i>Discovery Disabled</i> <i>Discovery Enabled</i>	<i>DiscoveryDisable</i> <i>DiscoveryEnable</i>		
Next CLHS Device Configuration	clhsNextDeviceConfig	When the camera is next powered up, the specified CLHS lane configuration will be set for the camera.	Beginner DFNC
<i>One Cable One Lane</i> <i>Two Cables One Lane</i>	<i>OneCableOneLane</i> <i>TwoCablesOneLane</i>		
Refresh GenCP Status	refreshGenCPStatus	Press to update the GenCP Status.	Beginner DFNC
Last GenCP Status	genCPStatus	If a feature read or write returns that it fails, read this feature to get the actual reason for the failure Returns the last error. Reading this feature clears it. Sopera only.	Beginner DFNC

CLHS 64b/66b Receive Error Count Selector	clhsErrorCountSelector	Select the error to count	Guru DFNC
<i>Cable A Corrupted Packet Count</i>	<i>CorruptedPacketCntA</i>	<i>Count of corrupted packets on cable A.</i>	
<i>Cable A Corrected Packet Count</i>	<i>CorrectedPacketCntA</i>	<i>Count of corrected packets on cable A.</i>	
<i>Cable B Corrupted Packet Count</i>	<i>CorruptedPacketCntB</i>	<i>Count of corrupted packets on cable B.</i>	
<i>Cable B Corrected Packet Count</i>	<i>CorrectedPacketCntB</i>	<i>Count of corrected packets on cable B.</i>	
CLHS 64b/66b Receive Error Count	clhsErrorCount	CLHS 64b/66b Receive Error Count	Guru DFNC
Refresh CLHS 64b/66b Receive Error Count	clhsErrorCountRefresh	Refresh the selected <i>clhsErrorCount</i> value.	Guru DFNC
Reset Receive Error Count	clhsErrorCountReset	Reset the selected <i>clhsErrorCount</i> value to 0.	Guru DFNC

Acquisition and Transfer Control Category

The Acquisition and Transfer controls, as shown by CamExpert, have parameters used to configure the optional acquisition modes of the device.

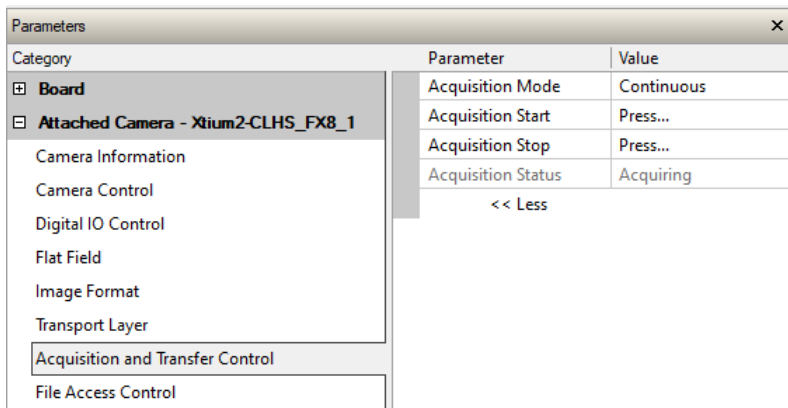

Figure 84: Acquisition & Transfer Control Panel

Acquisition and Transfer Control Feature Descriptions

Display Name	Feature	Description	View
Acquisition Mode <i>Continuous</i>	AcquisitionMode <i>Continuous</i>	The device acquisition mode defines the number of frames to capture during an acquisition and the way it stops <i>Only continuous mode is currently available.</i>	Beginner
Acquisition Start	AcquisitionStart	Commands the camera to start sending image data. (WO)	Beginner
Acquisition Stop	AcquisitionStop	Commands the camera to stop sending image data at the end of the current line (WO)	Beginner
Acquisition Status <i>Acquiring</i> <i>Not Acquiring</i>	AcquisitionStatus <i>Acquiring</i> <i>NotAcquiring</i>	Reads the acquisition state. <i>Currently acquiring and sending image data.</i> <i>Currently not acquiring or sending image data.</i>	Beginner

Features That Cannot Be Changed During a Transfer

The following features cannot be changed during an acquisition or when a transfer is connected.

Feature Group	Features Locked During a Spera Transfer
<u>CAMERA INFORMATION</u>	NA
<u>CAMERA CONTROL</u>	NA
<u>I/O CONTROL</u>	NA
<u>COUNTER AND TIMER CONTROL</u>	NA
<u>IMAGE FORMAT CONTROL</u>	PixelFormat AOI functions
<u>ACQUISITION AND TRANSFER CONTROL</u>	NA
<u>FILE ACCESS CONTROL</u>	NA

File Access Control Category

The File Access control in CamExpert allows the user to quickly upload and download various data files to/from the connected camera. The supported data files for the camera include firmware updates and Flat Field coefficients.

NOTE

Communication performance when reading and writing large files can be improved by stopping image acquisition during the transfer.

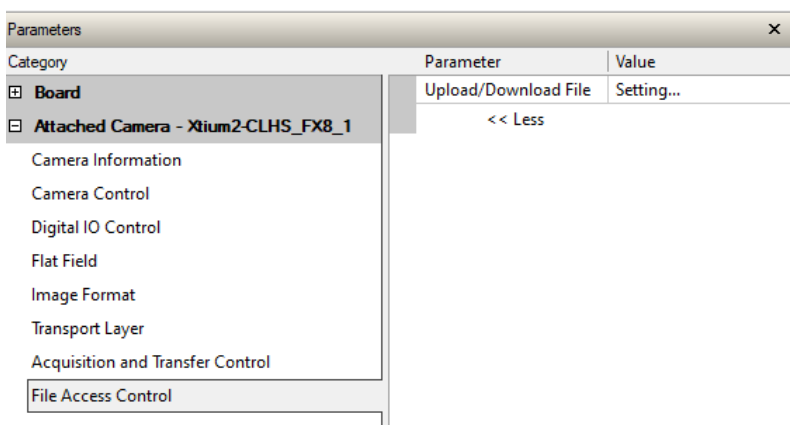



Figure 85: File Access Control Panel

File Access Control Feature Descriptions

BW Color	Display Name	Feature	Description	View
	File Selector	FileSelector	Selects the file to access. The files which are accessible are listed in the XML:	Beginner
	<i>All Firmware</i>	<i>Firmware1</i>	<i>Upload micro code, FPGA code & XML as a single file to the camera which will execute on the next camera reboot cycle.</i>	
	<i>User Set</i>	<i>User_Set</i>	<i>Use UserSetSelector to specify which user set to access.</i>	
	<i>Output LUT</i>	<i>Output_LUT</i>	<i>Use UserSetSelector to specify which LUT to access.</i>	
	<i>User PRNU</i>	<i>User_PRNU</i>	<i>Use UserSetSelector to specify which user PRNU to access.</i>	
	<i>User FPN</i>	<i>User_FPN</i>	<i>Use UserSetSelector to specify which user FPN to access.</i>	
	<i>Current PRNU</i>	<i>Cur_PRNU</i>	<i>Accesses the PRNU coefficients that are currently being used by the camera (not necessarily saved).</i>	
	<i>Camera_Data</i>	<i>CameraData</i>	<i>Download camera information and send for customer support.</i>	
	<i>Color Transformation</i>	<i>ColorTransform</i>	<i>Color transformation matrices.</i>	
	File Operation Selector	FileOperationSelector	Selects the operation for the selected file in the device. This operation is executed when the File Operation Execute feature is called.	Guru
	<i>Open</i>	<i>Open</i>	<i>Select the Open operation - executed by FileOperationExecute.</i>	
	<i>Close</i>	<i>Close</i>	<i>Select the Close operation - executed by FileOperationExecute.</i>	
	<i>Read</i>	<i>Read</i>	<i>Select the Read operation - executed by FileOperationExecute.</i>	

BW Color	Display Name	Feature	Description	View
		<i>Write</i>	<i>Write</i> <i>Select the Write operation - executed by FileOperationExecute.</i>	
	File Operation Execute	FileOperationExecute	Executes the operation selected by File Operation Selector on the selected file.	Guru
	File Open Mode	FileOpenMode	Selects the access mode used to open a file on the device. <i>Select READ only open mode</i> <i>Select WRITE only open mode</i>	Guru
		<i>Read</i> <i>Write</i>		
	File Access Buffer	FileAccessBuffer	Defines the intermediate access buffer that allows the exchange of data between the device file storage and the application.	Guru
	File Access Offset	FileAccessOffset	Controls the mapping offset between the device file storage and the file access buffer.	Guru
	File Access Length	FileAccessLength	Controls the mapping length between the device file storage and the file access buffer.	Guru
	File Operation Status	FileOperationStatus	Displays the file operation execution status. (RO).	Guru
	<i>Success</i>	<i>Success</i>	<i>The last file operation has completed successfully.</i>	
	<i>Invalid Parameter</i>	<i>InvalidParameter</i>	<i>An invalid parameter was passed to the last feature called.</i>	
	<i>Write Protect</i>	<i>WriteProtect</i>	<i>Attempt to write to a read-only (factory) file.</i>	
	<i>File Not Open</i>	<i>FileNotOpen</i>	<i>The file has not been opened yet.</i>	
	<i>File Too Big</i>	<i>FileTooBig</i>	<i>The file is larger than expected.</i>	
	<i>File Invalid</i>	<i>FileInvalid</i>	<i>The last file operation has completed unsuccessfully because the selected file is not present in this camera.</i>	
	File Operation Result	FileOperationResult	For Read or Write operations, the number of successfully read/written bytes is returned. (RO)	Guru
	File Size	FileSize	Represents the size of the selected file in bytes.	Guru

File Access via the CamExpert Tool

Click **Setting** to show the File Access Control dialog box.



Figure 86: File Access Control Tool

From the Type drop menu, select the file type that will be uploaded to the camera or downloaded from the camera.

From the File Selector drop menu, select the file to be uploaded or downloaded.

To upload a file, click **Browse** to open a typical Windows Explorer window.

- Select the specific file from the system drive or from a network location.
- Click **Upload (to Camera)** to execute the file transfer to the camera.

Alternatively, click **Download (from Camera)** and then specify the location where the file should be stored.

Firmware changes require that the camera be powered down and then back up. When the firmware update is successfully completed, a message box is displayed to reset the camera.

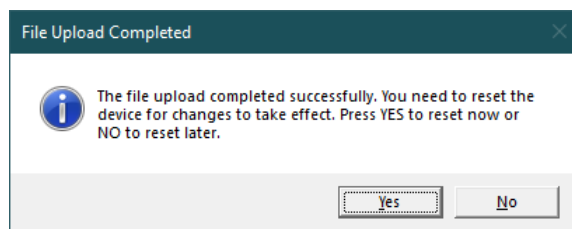

Figure 87: File Upload Completed Message Box

CAUTION

Do not interrupt the file transfer by powering down the camera or closing CamExpert.

CLHS File Transfer Protocol

If you are not using CamExpert to perform file transfers, pseudo-code for the CLHS File Transfer Protocol is as follows.

Download File from Camera

1. Select the file by setting the FileSelector feature.
2. Set the FileOpenMode to Read.
3. Set the FileOperationSelector to Open.
4. Open the file by setting FileOperationExecute to 1.
This is a read-write feature - poll it every 100 ms until it returns 0 to indicate it has completed.
5. Read FileOperationStatus to confirm that the file opened correctly; A return value of 0 is success. Error codes are listed in the XML.
6. Read FileSize to get the number of bytes in the file.
7. From FileAccessBuffer.Length you will know that maximum number of bytes that can be read through FileAccessBuffer is 988.
For Offset = 0 While ((Offset < FileSize) and (Status = 0)) Do
 - Set FileAccessOffset to Offset.
 - Set FileAccessLength to min (FileSize - Offset, FileAccessBuffer.Length), the number of bytes to read.
 - Set the FileOperationSelector to Read.
 - Read the file by setting FileOperationExecute to 1 and poll until 0 and complete.
 - Read FileOperationStatus to confirm the read worked
 - Read FileOperationResult to confirm the number of bytes read
 - Read the bytes from FileAccessBuffer
 - Write bytes read to host file.
8. Next Offset = Offset + number of bytes read.
9. Set the FileOperationSelector to Close.
10. Close the file by setting FileOperationExecute to 1 and poll until 0 and complete.
11. Read FileOperationStatus to confirm the close worked.

Upload File to Camera

1. Select the file by setting the *FileSelector* feature.
2. Set the *FileOpenMode* to Write.
3. Set the *FileOperationSelector* to Open.
4. Open the file by setting *FileOperationExecute* to 1. This is a read-write feature - poll it every 100 ms until it returns 0 to indicate it has completed.
5. Read *FileOperationStatus* to confirm that the file opened correctly; a return value of 0 is success. Error codes are listed in the XML.
6. Read *FileSize* to get the maximum number of bytes allowed in the file.
7. Abort and jump to Close if this is less the file size on the host.
8. From *FileAccessBuffer.Length* you will know that maximum number of bytes that can be written through *FileAccessBuffer* is 988.
9. For Offset = 0 While ((Offset < Host File Size) and (Status = 0)) Do
 - Set *FileAccessOffset* to Offset.
 - Set *FileAccessLength* to min (Host File Size - Offset, *FileAccessBuffer.Length*), the number of bytes to write.
 - Read the next *FileAccessLength* bytes from host file.
 - Write the bytes to *FileAccessBuffer*.
 - Set the *FileOperationSelector* to Write.
 - Write to the file by setting *FileOperationExecute* to 1 and poll until 0 and complete.
 - Read *FileOperationStatus* to confirm the write worked.
 - Read *FileOperationResult* to confirm the number of bytes written.
10. Next Offset = Offset + number of bytes written.
11. Set the *FileOperationSelector* to Close.
12. Close the file by setting *FileOperationExecute* to 1 and poll until 0 and complete.
13. Read *FileOperationStatus* to confirm the close worked.

Download a List of Camera Parameters

For diagnostic purposes you may want to download a list of all the parameters and values associated with the camera.

- Go to File Access Control.
- Click on Settings.
- In the “Type” drop down box select “Miscellaneous.”
- In the “File selector” drop down box select “CameraData.”
- Click “Download”.
- Save the text file and send the file to Teledyne DALSA customer support.

File Access Control

Select the type of file to upload or download from the device.

File Type Available

Type: Miscellaneous

File selector: Camera Data

Description: Camera Data - This is a text file, please ensure that it has a ".txt" file name extension.

Note: Depending on the file size and communication speed, the transfer could take many minutes, but must not be aborted.

File path:

Browse...

Upload (to Camera) Download (from Camera) Delete

Close

Appendix B: Troubleshooting Guide

Diagnostic Tools

Camera Data File

The modules data file includes the operational configuration and status of the camera

This text file can be downloaded from the camera and forwarded to Teledyne DALSA Technical Customer support team to aid in diagnosis of any reported issues. See the Saving & Restoring Camera Setup Configurations section for details on downloading the Camera Data file.

Voltage & Temperature Measurement

The module can measure the input supply voltage at the power connector and the internal temperature. Both of these features are accessed using the CamExpert > Camera Information tab. Press the associated refresh button for a real-time measurement.

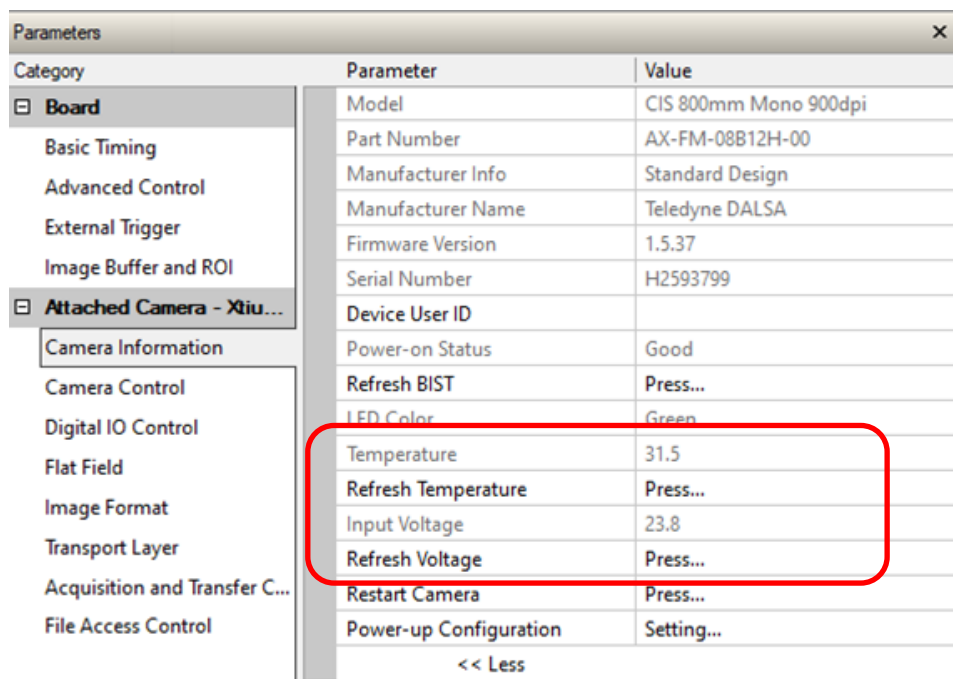

Category	Parameter	Value
Board	Model	CIS 800mm Mono 900dpi
	Part Number	AX-FM-08B12H-00
	Manufacturer Info	Standard Design
	Manufacturer Name	Teledyne DALSA
	Firmware Version	1.5.37
	Serial Number	H2593799
	Device User ID	
	Power-on Status	Good
	Refresh BIST	Press...
	LED Color	Green
Attached Camera - Xti...	Temperature	31.5
	Refresh Temperature	Press...
	Input Voltage	23.8
	Refresh Voltage	Press...
	Restart Camera	Press...
	Power-up Configuration	Setting...
	<< Less	

Figure 88: CamExpert Voltage & Temperature Features

Test Patterns – What Can They Indicate?

The module can generate fixed test patterns that may be used to determine the integrity of the CLHS communications beyond the Lock status. The test patterns give the user the ability to detect bit errors using an appropriate host application. This error detection would be difficult, if not impossible, using normal image data.

NOTE

Gray images are displayed so that any bit error is immediately apparent as brighter or darker pixels in the image.

There are four test patterns that can be selected using the Test Pattern feature, available in CamExpert in the Image Format category.

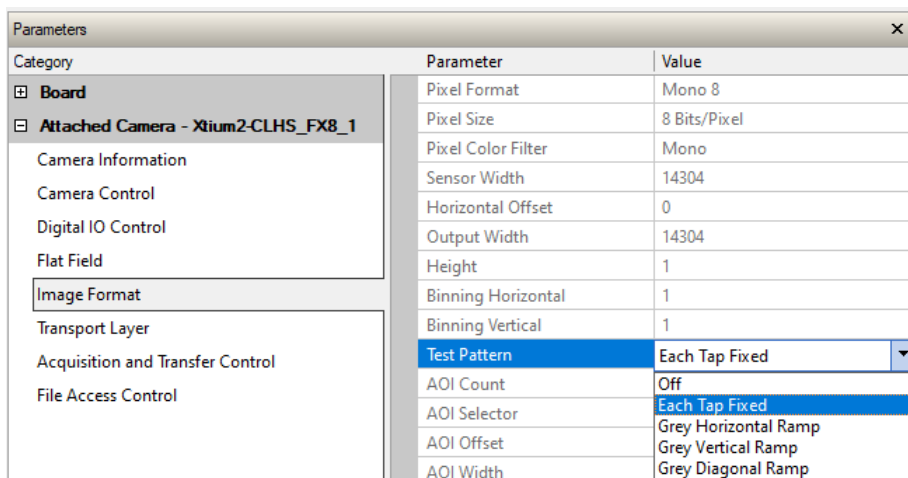

Figure 89: CamExpert Test Pattern Feature

They have the following format when using 8-bit data:

Test Pattern	Output Image
<p>Each Tap Fixed</p> <p>Starting at 64 increases in by 4 steps every 512 pixels ending in 188.</p>	
<p>Grey Horizontal Ramp</p> <p>2 horizontal ramps starting at 00H increase by 01H every 32 pixels.</p>	
<p>Grey Vertical Ramp</p> <p>Vertical ramp starting with 1st row 5, next row 12, and incrementing by 3 every line</p>	
<p>Grey Diagonal Ramp</p> <p>Add horizontal and vertical ramps</p>	

Built-In Self-Test Codes

The Built-In Self-test (BIST) codes are located in the Camera Information category under Power-on Status. If the Power-on-Status is not "Good" a hexadecimal code is displayed.

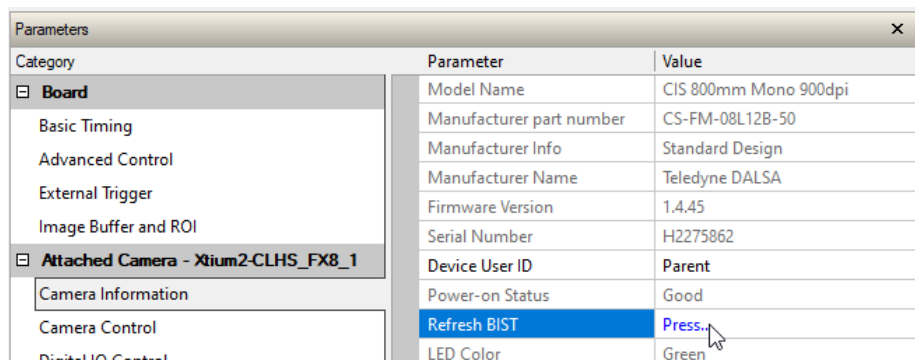

None of these should occur in a properly functioning module except OVER_TEMPERATURE.

OVER_TEMPERATURE occurs if the ambient temperature is too high where there is insufficient air circulation or heat sinking. The user can recover from OVER_TEMPERATURE by letting the camera cool down.

The user can recover from NO_USER_SETTINGS/FPN/PRNU by trying to saving settings, but is an unlikely event.

Table 19: Built-In Self-Test (BIST) Codes

Name	Hex Position
I2C	0x00000001
FPGA_NO_INIT	0x00000002
FPGA_NO_DONE	0x00000004
SENSOR_SPI	0x00000008
ECHO_BACK	0x00000010
FLASH_TIMEOUT	0x00000020
FLASH_ERROR	0x00000040
NO_FPGA_CODE	0x00000080
NO_COMMON_SETTINGS	0x00000100
NO_FACTORY_SETTINGS	0x00000200
OVER_TEMPERATURE	0x00000400
NO_USER_FPN	0x00001000
NO_USER_PRNU	0x00002000
CLHS_TXRDY_RETRY	0x00004000
INVALID_UPGRADE	0x00008000
NO_USER_SETTINGS	0x00010000
NO_FACT_FF	0x00400000
NO_FATFS	0x00800000
IN_FACTORY_PARTITION	0x01000000

Status LED

A single red / green LED is located on the back of the module to indicate status; refer to the [Status LED](#) section for a description of the LED states. The Status LED state is also available using the [LED Color](#) feature, available in CamExpert in the Camera Information category.

Resolving Camera Issues

Communications

No Camera Features when Starting CamExpert

If the camera's CamExpert is opened and no features are listed, then the camera may be experiencing lane lock issues.

While using the frame grabber in CamExpert you should be able to see a row of status indicators below the image display area that indicates the status of the CLHS communications. These indicators include seven lane lock status and a line valid (LVAL) status.

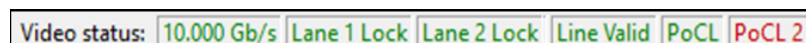

If the status for one or more lane locks is red, then there is likely an issue with the CLHS SFP+ connectors at the module and/or frame grabber. Verify that the connectors are fully engaged and locked in place and ensure that you are also using the recommended cables.

No LVAL

If the LVAL status is red and all lane locks are green, then there may be an issue with the module receiving the encoder pulses.

In CamExpert, in the module's Digital IO Control category, set the Trigger Mode to Internal and set the Acquisition Line Rate feature, in the Camera Control category, to the maximum that will be used.

The trigger signal from the frame grabber will not be used and the LVAL status should now be green. This will confirm the integrity of the image data portion of the CLHS cabling and connectors.

From the camera's **CamExpert > Digital I / O Control** tab, select External Trigger Mode.

From the Frame Grabber CamExpert > Advanced tab, select the Line Sync Source to be Internal Line Trigger and the Internal Line Trigger frequency to the maximum that will be used.

The trigger source is now being generated by the frame grabber and the LVAL status should be green. This will confirm the integrity of the General Purpose I / O portion of the CLHS cabling and connectors.

From the Frame Grabber CamExpert > Advanced tab, select the Line Sync Source to be External Line Trigger and select the Line Trigger Method to Method 2 under the same tab.

From the Frame Grabber CamExpert > External Trigger tab, select External Trigger to be enabled. If LVAL status turns red, check the following:

- Is the transport system moving such that encoder pulses are being generated?
- Has the encoder signal been connected to the correct pins of the I/O connector of the frame grabber? See the Xtium2-CLHS frame grabber user manual for details.
- Do the encoder signal levels conform to the requirements outlined in the Xtium2-CLHS frame grabber user manual?

Image Quality Issues

Vertical Lines Appear in Image after Calibration

The purpose of flat field calibration is to compensate for pixel response variations and imperfections in the illumination profiles by creating a uniform response. When performing a flat field calibration, the camera must be imaging a flat white target that is illuminated by the actual lighting used in the application. Though the module compensates for illumination imperfections, it also compensates for imperfections such as dust, scratches, paper grain, etc., in the white reference. After the white reference is removed and the camera images the material to be inspected, any white reference imperfections will appear as vertical stripes in the image. If the white reference had imperfections that caused dark features, there will be a bright vertical line during normal imaging. Similarly, bright features will cause dark lines. It can be very difficult to achieve a perfectly uniform, defect-free white reference. The following two approaches can help in minimizing the effects of white reference defects:

- Move the white reference closer to or further away from the object plane such that it is out of focus. This can be effective if the illumination profile changes minimally when relocating the white reference.
- If the white reference must be located at the object plane, then move the white reference in the scan direction or sideways when flat field calibration is being performed. The module averages several thousand lines when capturing calibration reference images, thereby averaging out any small imperfections.

Over Time, Pixels Developing Low Response

When flat field calibration is performed using a white reference, as per the guidelines in the user manual, all pixels should achieve the same response. However, over time dust in the module windows may reduce the response of some pixels.

If the dust particles are small, they may have only a minor effect on responsivity, but still create vertical dark lines that interfere with defect detection and that need to be corrected. Window cleaning is required.

Because repeating the flat field calibration with a white reference or cleaning may not be practical with the module installed in the system, the module has a feature where the flat field coefficients can be downloaded to the host PC and adjusted using a suitable application, such as Microsoft Excel; see the section [File Access Control Category](#) for details.)

If the location of the pixel returning a low response can be identified from the image, then the correction coefficient of that pixel can be adjusted, saved as a new file, and then uploaded to the camera; thereby correcting the image without performing a flat field calibration.

See the File Access via the CamExpert Tool for details on downloading and uploading camera files using CamExpert.

Smear & Distorted Images

To achieve a well-defined image, the staggered sensor outputs are delayed in a manner that matches the motion of the image across the sensor.

This synchronization is achieved by sending an external synchronization (EXSYNC) signal to the module, where one pulse is generated when the object moves by the size of one object pixel; refer to the [TriggerMode](#) feature.

Any transport motion that is not correctly reflected in the EXSYNC pulses will cause image distortion in the scan direction.

The following subsections discuss causes of poor image quality resulting from the EXSYNC signal not accurately reflecting the object motion.

Vertically Staggered Images

When accurate synchronization is not achieved, the image will have a vertical stagger in pixel sections of 297 (300 dpi), 447 (450 dpi) 595 (600 dpi) and 893 (900 dpi) in the scan direction.

If the EXSYNC pulses are coming too fast, then the image will appear stretched in the machine direction. If the pulses are too slow, then the image will appear compressed.

Check the resolution of the encoder used to generate the EXSYNC pulses, along with the size of the rollers, pulleys, gearing, etc. to ensure that one pulse is generated for one pixel size of travel of the object. Use the EXSYNC multiplier feature to adjust the pulses if the encoder cannot produce the desired pixel size.

It is also important that the direction of image travel across the sensor is matched to the module's scan direction, as set by the user; refer to the *Scan Direction* feature for more information.

If the scan direction is incorrect, then the image will have a significant staggered appearance and in the scan direction. Changing the scan direction to the opposite direction should resolve this problem.

Refer to the C section for more information on how to determine the correct direction orientation for the camera.

NOTE

The Selfoc Lens Array (SLA) used in the module does not have the reversing effect on motion as with regular lenses. That is, if an object passes the module from left to right, the image also will pass from left to right.

Randomly Compressed Images

It is possible that when the scan speed nears the maximum allowed, based on the exposure time used, the image will be randomly compressed and possibly staggered for short periods in the scan direction.

This is indicative of the inspection systems transport mechanism dynamics causing momentary over-speed conditions. The module can tolerate very short durations of over-speed, but if it lasts too long, then the camera can only maintain its maximum line rate, and some EXSYNC pulses will be ignored, resulting in the occasional compressed staggered image.

Over-speeding may be due to inertia and/or backlash in the mechanical drive mechanism, causing variations around the target speed.

The greater the speed variation, the lower the target speed needs to be to avoid over-speed conditions. If the speed variation can be reduced by eliminating the backlash in the transport mechanism and/or optimizing the motor controller characteristics, then a higher target speed will be achievable.

Distorted Image when Slowing Down Changing Direction

The module must align the rows in a fashion that accurately follows the object motion.

When the scan direction changes, then the process must reverse to match the reversed image motion across the sensor. Only when all delayed rows have received will the correct image be output correctly.

Power Supply Issues

For safe and reliable operation, the module input supply must be within +24V DC. $\pm 10\%$.

The power supply to the module should be suitably current limited, as per the current specifications.

Assume a worst-case power consumption at 150% current rating for the breaker or fuse.

NOTE

The camera will not start to draw current until the input supply is above approximately 20V and 200 ms has elapsed. If the power supply stabilizes in less than 200 ms, then inrush current will not exceed normal operating current.

It is important to consider how much voltage loss occurs in the power supply cabling to the camera, particularly if the power cable is long and the supply is operating at +24V -10% where the current draw is highest.

Reading the input supply voltage as measured by the camera will give an indication of the supply drop being experienced.

The module tolerates "hot" unplugging and plugging, though not recommended. Connect all supplies before turning the supply on.

The module has been designed to protect against accidental application of an incorrect input supply, up to reasonable limits.

With the following input power issues, the status LED will be OFF:

- The module protects against the application of voltages above approximately +28 V. If the overvoltage protection threshold is exceeded, then power is turned off to the camera's internal circuitry. The power supply must be recycled to recover camera operation. The input protection circuitry is rated up to an absolute maximum of +30 V. Beyond this voltage, the camera may be damaged.
- The camera protects against the accidental application of a reverse input supply up to a maximum of -30 V. Beyond this voltage, the camera may be damaged.
- The module does not power-up below approximately 20 V.

Declarations of Conformity

Copies of the Declarations of Conformity documents are available on the product page on the [Teledyne DALSA website](#) or by request.

FCC Statement of Conformance for Class A

This equipment complies with Part 15 of the FCC rules. Operation is subject to the following conditions:

1. The product may not cause harmful interference; and
2. The product must accept any interference received, including interference that may cause undesired operation.

This equipment has been tested and found to comply with the limits for a Class A digital device, pursuant to part 15 of the FCC Rules. These limits are designed to provide reasonable protection against harmful interference when the equipment is operated in a commercial environment. This equipment generates, uses, and can radiate radio frequency energy and, if not installed and used in accordance with the instruction manual, may cause harmful interference to radio communications. Operation of this equipment in a residential area is likely to cause harmful interference in which case the user will be required to correct the interference at his own expense.

Changes or modifications not expressly approved by the party responsible for compliance could void the user's authority to operate the equipment.

This equipment is intended to be a component of a larger industrial system.

EU and UKCA Declaration of Conformity

Teledyne DALSA declares that this product complies with applicable standards and regulations.

Changes or modifications not expressly approved by the party responsible for compliance could void the user's authority to operate the equipment.

This product is intended to be a component of a larger system and must be installed as per instructions to ensure compliance.

Document Revision History

Revision	Description	Date
00	Preliminary Version	Jan 10, 2023
01	Added features to adjust individual pixel PRNU values	Feb 6, 2023
02	Updated pin out on I/O D-sub	Sept 20, 2023
03	800 mm Production Release	Oct 18, 2023
04	400 mm Production Release	Dec 12, 2023
05	General update for latest release.	Mar 8, 2024
06	400 mm Color Production Release. Table 4 – add additional resolutions 300/450/600/900dpi. All models support 4 resolutions in August 2024.	July 4, 2024
07	Updated Response Levelling features, LUT section. Added 1500mm model.	October 4, 2024
08	Added 700mm model, LED specifications and safety information.	January 17, 2025
09	Updated power dissipation, LED specifications and safety information.	January 23, 2025
10	Updated safety information. Added LED option for 1500mm model.	March 25, 2025
11	Added 600mm color model.	June 27, 2025
12	Added 800mm color model, short boot optical cable, crosstalk correction.	November 10, 2025

Contact Information

Sales Information

Visit our web site:	www.teledynevisionsolutions.com
Email:	info@teledynevisionsolutions.com

Canadian Sales	Canadian Sales
Teledyne DALSA — Head office 605 McMurray Road Waterloo, Ontario N2V 2E9 Canada Tel: +1 519-886-6000 Fax: +1 519-886-8023	Teledyne DALSA — Montreal office 880 Rue McCaffrey Saint-Laurent, Quebec H4T 2C7 Canada Tel: +1 514-333-1301 Fax: +1 514-333-1388
USA Sales	European Sales
Teledyne DALSA — Billerica office 700 Technology Park Drive Billerica, MA 01821 USA Tel: +1 978-670-2000 Fax: +1 978-670-2010 sales.americas@teledynedalsa.com	Teledyne DALSA GMBH Lise-Meitner-Str. 7 82152 Krailling (Munich) Germany Tel: +49 89-89545730 Fax: +49 89-895457346 sales.europe@teledynedalsa.com
Asia Pacific Sales	China Sales
Teledyne DALSA Asia Pacific Ikebukuro East 6F 3-4-3 Higashi Ikebukuro, Toshima-ku Tokyo, 170-0013 Japan Tel: +81 3-5960-6353 Fax: +81 3-5960-6354 sales.asia@teledynedalsa.com	Teledyne DALSA Asia Pacific Room 904, Block C, Poly West Bund Center 275 Rui Ping Road Shanghai 200032 China Tel: +86 21-60131571 sales.asia@teledynedalsa.com

Technical support

Submit any support question or request via our web site.

Technical support form via our web page: Support requests for imaging product installations, Support requests for imaging applications	https://www.teledynevisionsolutions.com/support/support-center/
Camera/sensor support information	
Product literature and driver updates	