

GoMax[®] ORIN / ORIN+

SMART 3D VISION ACCELERATORS

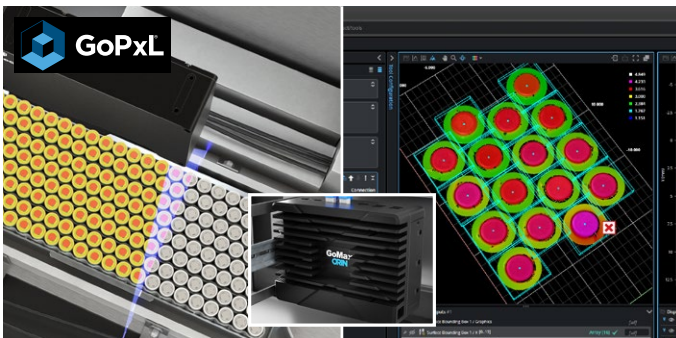

Powered by **NVIDIA[®] Jetson Orin™**



EV Battery Cell Inspection with GoMax Acceleration in GoPXL

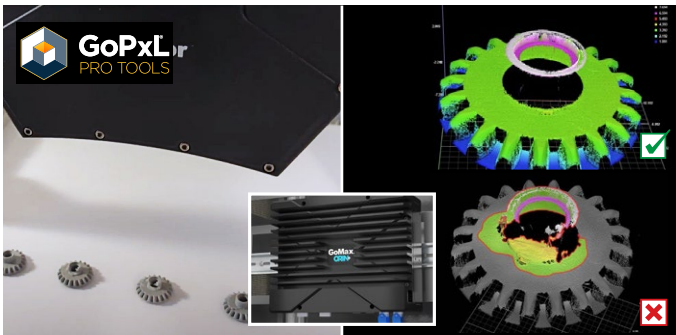

Gear inspection with GoPXL Anomaly Detector running on GoMax ORIN+

The new GoMax ORIN smart 3D vision accelerators provide higher levels of performance to support increasingly demanding machine vision inspection requirements.

- Easy to set up, power, and run using a web browser interface
- Dedicated edge device with no additional drivers or OS maintenance
- Deployed with Gocator snapshot and line confocal sensors to increase scan rates
- Used in multi-sensor alignment installations to reduce cycle time
- Delivers multi-core CPU and powerful GPU to accelerate both traditional and AI-based inspection tools in a compact, fanless format
- Provides up to >2X faster acceleration than GoMax NX
- Runs GoPXL IIoT Vision Inspection Software

PLUG. PLAY. ACCELERATE.

Simply connect GoMax ORIN to any Gocator sensor and use the intuitive Gocator web browser-based interface to activate sensor acceleration. GoMax ORIN and ORIN+ provide multiple network interfaces that allow for easy acceleration of multi-sensor systems without the need for Ethernet switches.

POWERED BY NVIDIA[®] JETSON ORIN™ PROCESSING ARCHITECTURE

The base GoMax ORIN model leverages the NVIDIA[®] Jetson Orin™ NX system-on-module with 100 TOPS (Tera Operations Per Second) of performance for challenging applications that require accelerated single and multi-sensor data processing. The more powerful ORIN+ model leverages the NVIDIA[®] Jetson AGX Orin™ system-on-module that delivers server-class processing capability and up to 200 TOPS of advanced performance for deploying AI-based solutions.

SUPERCHARGED DATA PROCESSING POWER

GoMax ORIN and ORIN+ are compact, fanless, and easy-to-use smart embedded devices that enhance data processing power in real-time (including data generation, 3D measurement, and PLC/robot communication), minimizing cycle times and increasing overall inspection performance so you can achieve optimal results in heavy data processing applications.

SUPPORTS GOPXL ANOMALY DETECTOR

GoPXL Anomaly Detector is LMI's 3D defect detection solution that relies on traditional and AI-based tools in GoPXL to solve challenging applications in the production of parts for the automotive, food, building materials, tire, and many other industries. Users can train and deploy the solution all onboard GoMax without relying on cloud or additional GPU for initial and subsequent model training.

GoMax Specifications	GoMax ORIN	GoMax ORIN+
GPU Platform	NVIDIA Jetson Orin NX	NVIDIA Jetson AGX Orin
Dimensions (L x W x H) (mm)	180 x 136 x 75	210 x 164 x 74
Weight (kg)	2.5	2.9
Operating Temperature (°C)	-15 - 60	-20 - 55
Certifications	CE, FCC, UKCA, KCC, RoHS, Reach	CE, FCC, UKCA, KCC, RoHS, Reach
Mounting	DIN rail, Wall mounting	DIN rail, Wall mounting
CPU	8-core NVIDIA Arm® Cortex®-A78AE v8.2 64-bit CPU 2MB L2 + 4MB L3	12-core NVIDIA Arm® Cortex®-A78AE v8.2 64-bit CPU 3MB L2 + 6MB L3
Performance (Tera Operations Per Second)	100	200
GPU	Ampere, 1024 CUDA cores, 32 Tensor cores	Ampere, 1792 CUDA cores, 56 Tensor cores
Memory	16 GB LPDDR5 onboard	32 GB LPDDR5 onboard
Storage (non-volatile)	128 GB SSD	512 GB SSD
Ethernet Ports	5x GigE	4x GigE
Power (Max draw is without PoE)	12-24 VDC, max 25W	12-24 VDC, max 40W
Power Connector	Phoenix (2-pin terminal block)	Phoenix (2-pin terminal block)
Use Cases	Sensor and measurement tool acceleration, Anomaly Detector training	Sensor and measurement tool acceleration, demanding Anomaly Detector training

ORIN

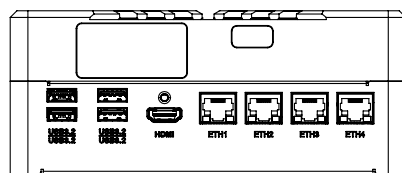
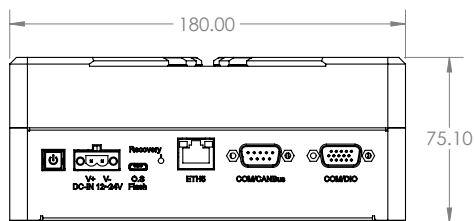
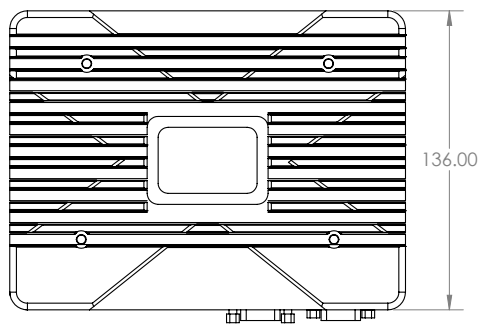

ORIN+

