

LED Lighting Digital Control Units

CD-VA Series Total 4 Models

Compact and Multifunctional DC Input Type Control Units

Compact size for easier handling (actual size)



Output Channels

2/4-channel
(max. 16 channels*)

*With 4 control units connected

Lighting Output

2-channel: 100 W
4-channel: 200 W
(max. 50 W/channel)

Communication Method

Ethernet
Parallel
USB
RS-232C*

*Using parallel terminals

Power Input

24 VDC Input

PWM control

Variable-voltage control

Strobe overdrive



▶ Total 4 models in the lineup



Model name	Number of channels	Lighting output	Ethernet communication
CD-VA10024-2P	2 channels	Max. 100 W	–
CD-VA20024-4P	4 channels	Max. 200 W	–
CD-VA10024-2PE	2 channels	Max. 100 W	○
CD-VA20024-4PE	4 channels	Max. 200 W	○

CD-VA Series

Features

- ▶ Lighting output of **100 W** with 2 channels and **200 W** with 4 channels available (Max 50W for each channel)
- ▶ **Up to 4 units** can be connected via infrared communication
- ▶ **3 intensity control methods** can be set by channel
- ▶ Clear and visible display screen and high operability

Compact design with balanced operability and functionality

Clear and visible display screen

Liquid crystal display, supporting English and Japanese.

High operability

Divided into dial, LAMP, and MODE buttons for simple operation.

Supports Ethernet communication (CD-VA10024-2PE / CD-VA20024-4PE)

Supports DHCP for automatic acquisition of information such as IP addresses. Just connect a LAN cable to launch communication.



CD-VA20024-4PE

Infrared communication between units

Since units communicate with one another via infrared, cables are not required. Up to 4 units can be connected, for up to 16 channels in use. Setting copy function applies settings to each channel.

Equipped with general-purpose output terminal

Use general-purpose output terminals in parallel communication for checking lighting status, error outputs, etc.

Equipped with USB connector (USB Type-C)

Just connect a PC with a USB cable to use the dedicated application.

Lighting Control Functions

Full range of control functions in compact housing

1

Supports 3 Intensity Control Methods

Select the intensity control method suitable to the inspection conditions.

PWM control

Variable-voltage control

Strobe overdrive

2

Up to 4 Units Connectable

The use of infrared communication allows for up to 4 units to be connected cable-free. Multiple units can be controlled through external communication with one main unit.



3

Sequence Control

Maximum 16 steps of pattern lighting can be set.

Example of 4-step setup

	0	1	2	3
L1				●
L2			●	
L3		●		
L4	●			

● : Lt

4

Recipe Setting Function

Up to 16 lighting setting parameters can be saved.

Parameters are set for each channel

Register up to **16** recipes



Supports 3 Intensity Control Methods

Choose the control method for each channel between general PWM (pulse width modulation), variable-voltage control suited to line scan camera inspections, and strobe overdrive allowing brighter lighting.

One control unit supports various inspection conditions.

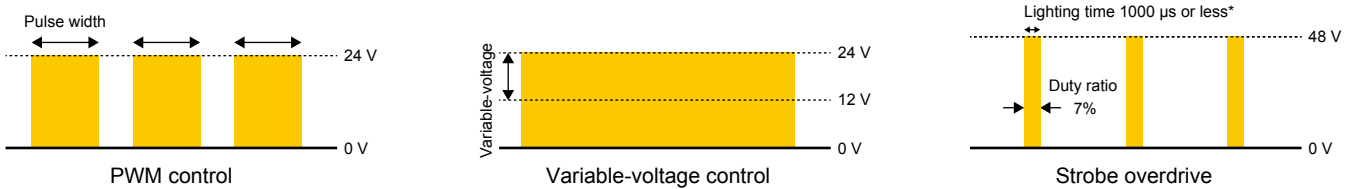

* Operates when lighting time is 1,000 μs or less. When the lighting time is set in units of ms, the strobe overdrive does not operate. Operation is at normal voltage (24 V).

Variable-voltage control dimmer range

Dimmer range can be switched between 2 levels. Select in accordance with lighting characteristics or applications.

Variable-voltage range: LOW/12 to 24 V

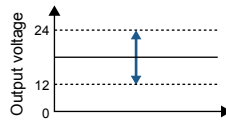

Variable-voltage range: HIGH/18 to 24 V

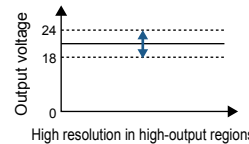

Depending on the characteristics of the lighting in use, the dimming value when lighting starts may vary and lights may turn ON even at a dimming value of 0.

Up to 4 Units Connectable

Maximum **16-channel** control is available*1

*1: With 4 units of the 4-channel model connected

Up to 4 units can be connected to control via infrared communication.

For example, with four units of the 4-channel type connected, the lighting parameters can be set for up to 16 channels.

External control cables for each unit are unnecessary as the parent unit can control settings on the connected units. By using the setting copy function, setting can be easily reflected to each channel, allowing for reduced workload.



Caution: For ON/OFF control via trigger input, individual connection to control unit and control is required.

Control to expansion units

Only the main unit can control the connected expansion units. Setting controls on an expansion unit does not apply the same changes to the main unit and the other expansion units.



Ethernet communication
Parallel communication
RS-232C communication

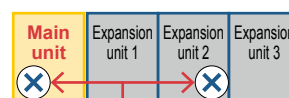

Ethernet communication
Parallel communication
RS-232C communication

Can also be connected with the Optex FA OPPX Series.



* When using CD-VA as a main unit, OPPX Series, FALUX sensing+ function is unavailable.

Sequence Control

Program up to 16 steps of ON input for a pattern of light emission with desired intensity and emission time. For example, when using 4-quadrant bar lights or segmented lights to illuminate from multiple directions, the emission patterns for each channel can be stored and switched ON/OFF by trigger input.

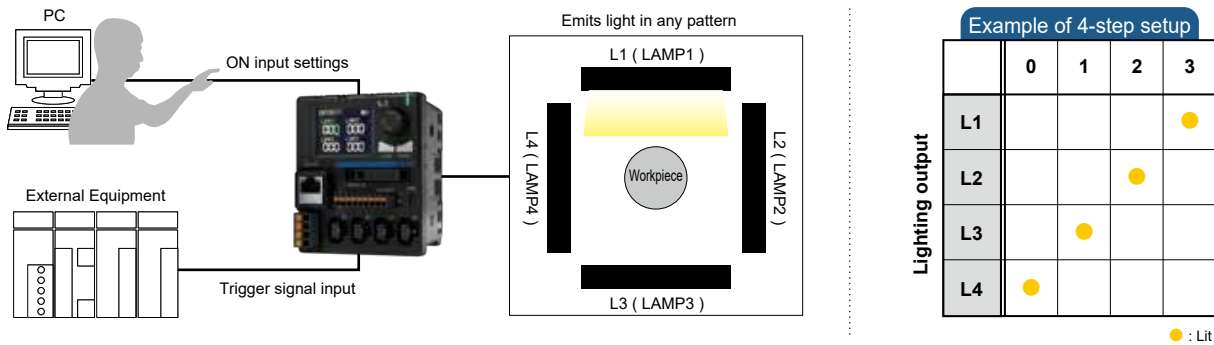

Sequence control application examples

Photometric stereo imaging

The workpiece is illuminated and imaged from 4 directions. It is possible to generate images that highlight only the unevenness or extract only the pattern by using the differences of each captured image.

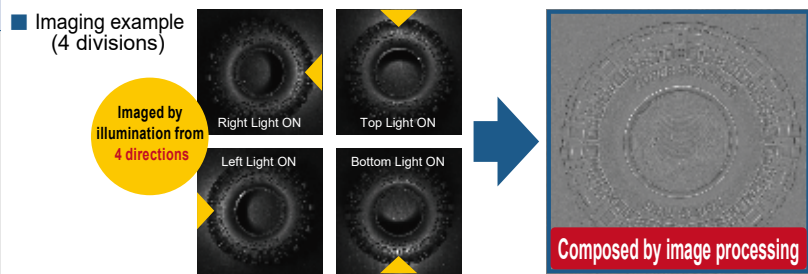

Recipe Setting Function

Up to 16 lighting setting parameters can be saved

Parameter settings such as intensity values for each channel and other inspection-specific parameter settings can be registered in advance, allowing for easy setting changes simply by recalling recipes.

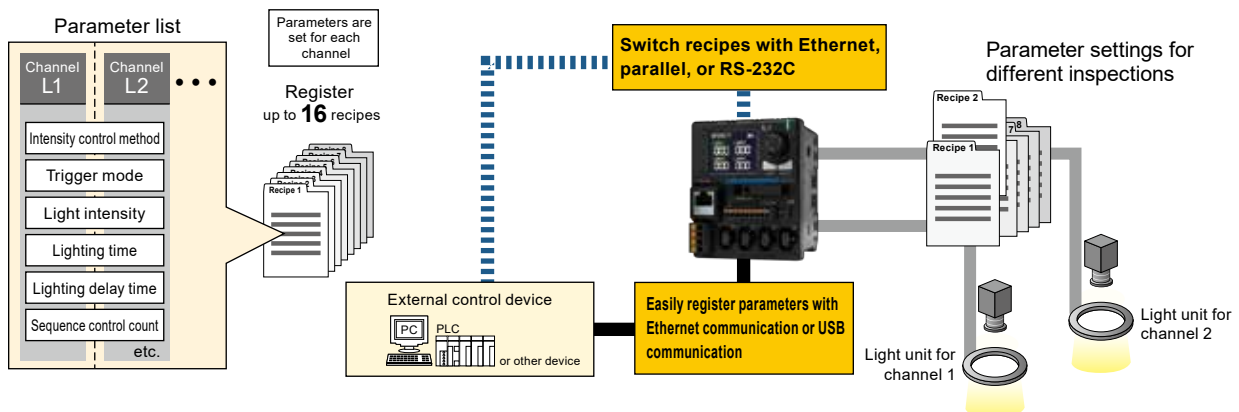

Trigger Input Assignment Function

Control ON/OFF of multiple lights with 1 trigger input. Change assignments even after wiring.

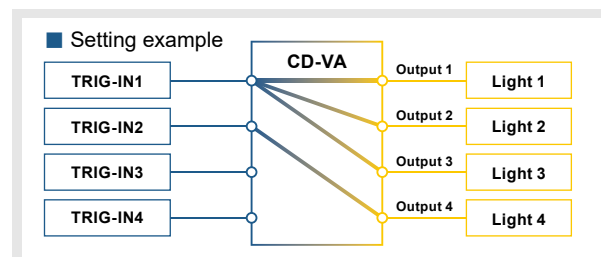

External Signal Connection Example

(Both NPN and PNP connections are supported and logic switching is possible.)

NPN connection (sink connection)

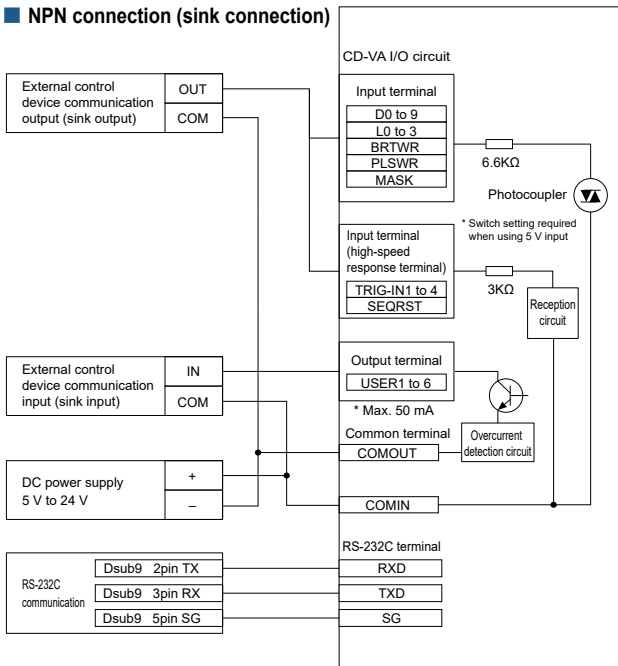

PNP connection (source connection)

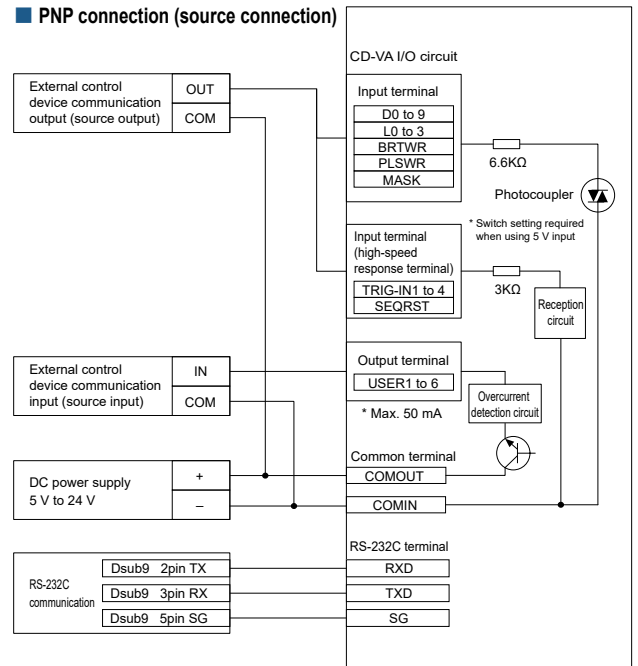

Enhanced Status Confirmation Functions

Status of the control unit and light (errors, ON/OFF, etc.) can be confirmed using the output**1 function

*1 There are two output systems: parallel and trigger pin.

Usage example: Trigger input ready status confirmation

Output ON: each channel can accept a trigger input. Output OFF: light in operation (ON, strobe, etc.).

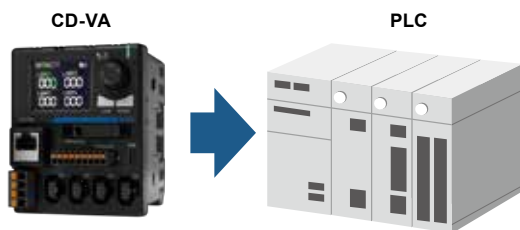

Operation	Output
Trigger input ready	ON
Trigger input will not be accepted while light is on	OFF

Output timing example

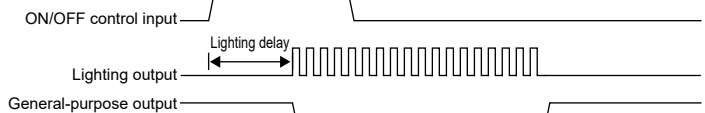

USB connector (Type-C) for data communication with a PC even while connected to external control devices

USB connection image

Check settings and verify operation using the CD-VA dedicated app (utility software).

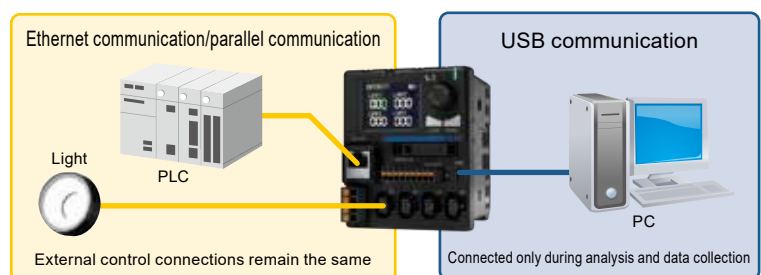

Common Specifications

Model name		CD-VA10024-2P	CD-VA20024-4P	CD-VA10024-2PE	CD-VA20024-4PE
Input voltage		24 VDC ±10%			
Lighting method		Continuous lighting, strobe lighting (overdrive when emission time is 1000 µs or less)			
Drive method		Constant-voltage system			
Intensity control method		PWM control (frequency: 100 kHz, 130 kHz), variable-voltage control			
Number of channels		2 channels	4 channels	2 channels	4 channels
Applicable light units (rated)		24 VDC light units 2 channels total: 100W (1 channel 50 W or less)	24 VDC light units 4 channels total: 200W (1 channel 50 W or less)	24 VDC light units 2 channels total: 100W (1 channel 50 W or less)	24 VDC light units 4 channels total: 200W (1 channel 50 W or less)
Lighting output voltage	PWM mode	24 VDC			
	Strobe mode ^{*1 *2}	48 VDC <small>*1 Automatically switches to 24 VDC drive when strobe emission time exceeds 1 ms.</small>			
	Variable-voltage mode	LOW: 12 to 24 V, HIGH: 18 to 24 V			
Lighting output current	Strobe mode ^{*3}	5.0 A/channel (duty 7%)			
Strobe emission time	PWM frequency: 100 kHz	Lighting time: 10 µs to 9,990 µs (10 µs steps), 1 ms to 999 ms (1 ms steps)			
	PWM frequency: 130 kHz	Lighting time: 7.7 µs to 7684.6 µs (7.7 µs steps), 1 ms to 999 ms (1 ms steps)			
	Lighting cycle limit	Duty 7% (requires cycle of 14.3x or more pulse width)			
External control method		USB communication (full-speed, Type-C connector), parallel communication, RS-232C communication		Ethernet communication (10BASE-T/100BASE-TX), USB communication (full-speed, Type-C connector), parallel communication, RS-232C communication	
Communication interface	USB	Serial communication via virtual COM port			
	RS-232C	4800 / 9600 / 19200 / 38400 / 57600 / 115200 bps			
	Ethernet	UDP, TCP, DHCP Client			
Operating environment		Temperature: 0 to 40°C, humidity: 20 to 85% RH (no condensation)			
Storage environment		Temperature: -20 to 60°C, humidity: 20 to 85% RH (no condensation)			
Cooling method		Natural air cooling			
Vibration resistance		10 to 55 Hz, double amplitude 1.5 mm, X, Y, Z directions 2 hours each			
Impact resistance		Approx. 10 G, X, Y, Z directions 3 times each			
Degree of protection		IP20 (IEC 60529)			
Environmental regulations		RoHS, REACH			
Compatible standards		CE, UKCA (Non-compliant with KC)			
Material/surface processing		Polycarbonate			
Weight		260 g	360 g	260 g	360 g
Accessories		Hardware manual x1, trigger connector x1, power connector x1			

*2 See the URL below for the combinations of LED lighting available when using strobe overdrive.

<https://www.ccs-grp.com/support/matching/check/>

*3 Overdrive is unavailable in variable-voltage mode.

■ 24 VDC power supply capacity

The 24 VDC control unit should be selected according to the total power consumption of the light used, based on the graph to the right.

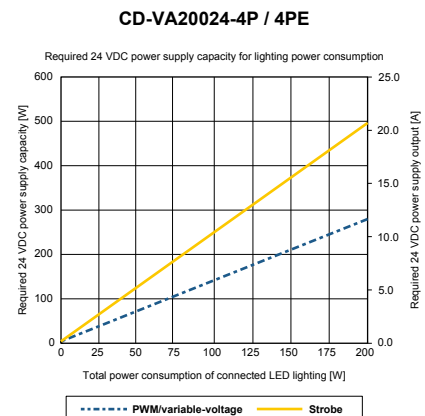
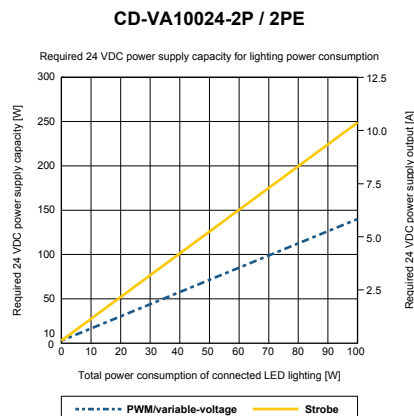

Note: When using with other devices, select a control unit depending on the device characteristics, leaving sufficient margin (approx. 2x) compared to the graph.

Options (sold separately)

* For details, including compliance with environmental regulations, please contact your local sales office.

Trigger cable

Model name: OP-ECBX9-3

* This product comes with 9 wires/set.

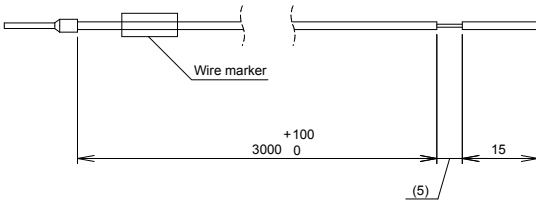

Wire marker numbers	Signal name	Wire color
1	Trigger input 1	Brown
2	Trigger input 2	Red
3	Trigger input 3	Orange
4	Trigger input 4	Yellow
5	Sequence reset input	Green
6	Input COM	Blue
7	General-purpose output 1	Violet
8	General-purpose output 2	Gray
9	Output COM	White

External control cable

Model name: OP-ECBX32-3

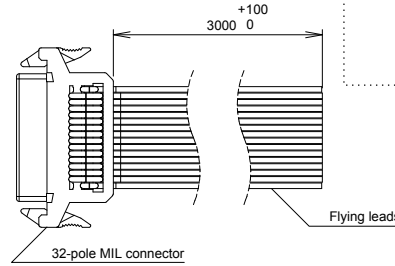

PIN No.	Signal name	Wire color	PIN No.	Signal name	Wire color	PIN No.	Signal name	Wire color
1	Dimming bit 0	Brown	12	Lamp switching 1	Red	23	General-purpose output 2	Violet
2	Dimming bit 0	Red	13	Lamp switching 2	Orange	24	General-purpose output 3	Gray
3	Dimming bit 0	Orange	14	Lamp switching 3	Yellow	25	General-purpose output 4	White
4	Dimming bit 0	Yellow	15	Dimming value write	Green	26	General-purpose output 5	Black
5	Dimming bit 0	Green	16	Input COM	Blue	27	General-purpose output 6	Brown
6	Dimming bit 0	Blue	17	RS-232C reception input	Brown	28	Output COM	Red
7	Dimming bit 0	Violet	18	RS-232C sending output	Red	29	Trigger input 1	Orange
8	Dimming bit 0	Gray	19	RS-232C common terminal	Orange	30	Trigger input 2	Yellow
9	Dimming bit 0	White	20	Lighting time write	Yellow	31	Trigger input 3	Green
10	Dimming bit 0	Black	21	Write mask	Green	32	Trigger input 4	Blue
11	Lamp switching 0	Brown	22	General-purpose output 1	Blue			

Ferrite core

Model name: OP-NFT-13S

Recommended installation location: Lighting output cable termination of CD-VA

Dimensions(mm)

CD-VA20024-4PE (with Ethernet communication)

* All models have the same external dimensions

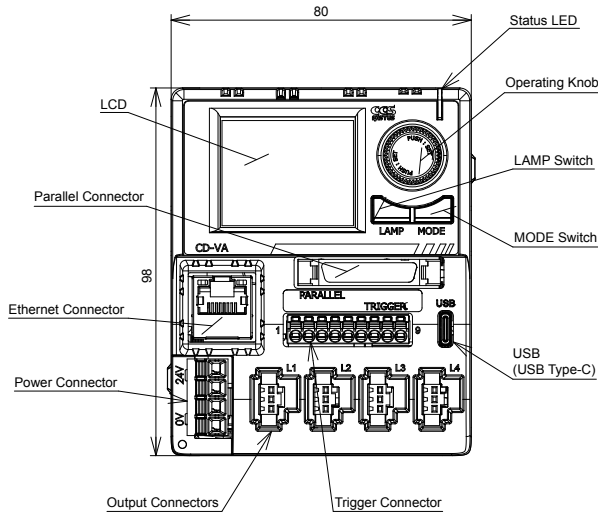

* CD-VA10024-2PE has 2 output connectors.

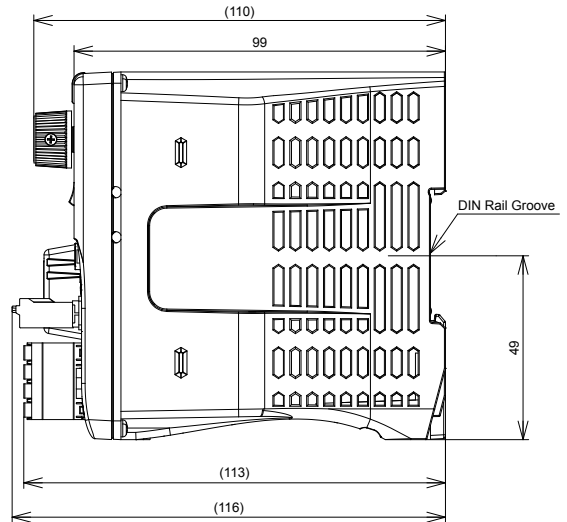

CD-VA10024-2P/CD-VA20024-4P (without Ethernet communication)

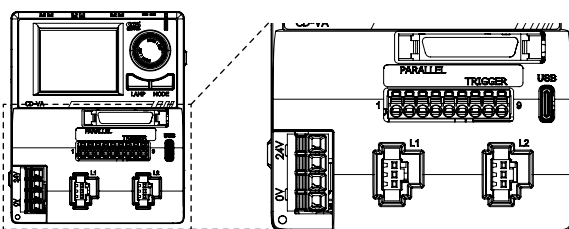

* CD-VA20024-4P has 4 output connectors.

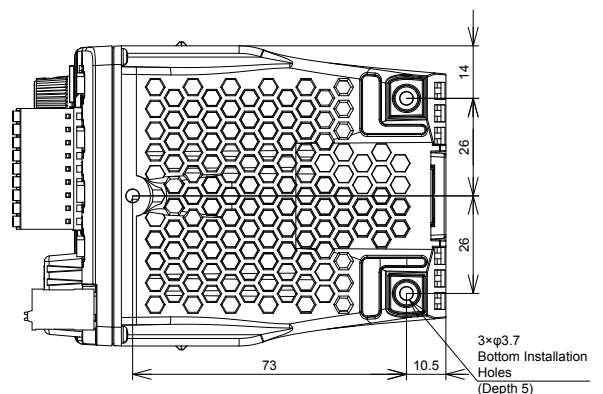

Setting Application CD-VA Dedicated App (Utility Software)

A dedicated app to easily set lighting parameters can be downloaded from the website.

<https://www.ccs-grp.com/products/series/386>

Set each channel's dimming value and ON/OFF control, as well as sequence control, recipe setting, ON/OFF input assignment, etc. The app also monitors operation status.

Setting screen



Sequence control setting screen



Recipe setting screen



Lighting operation status monitoring screen

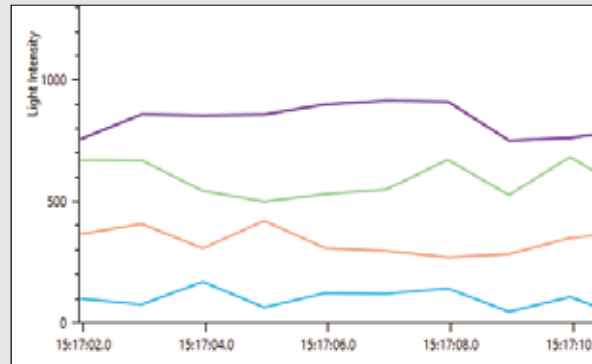
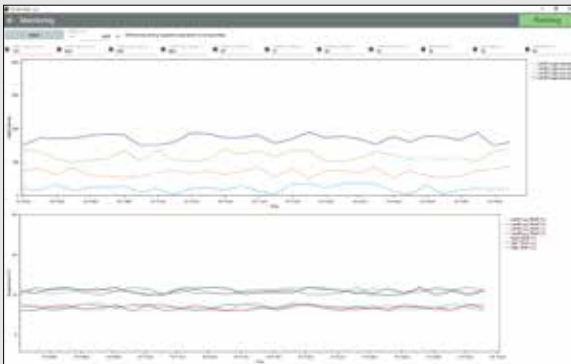

For more information about this product,
please refer to the hardware manual and operation manual.

< Downloadable from the web page > <https://www.ccs-grp.com/products/series/386>

■ "CCS" and "LIGHTING SOLUTION" are registered trademarks or trademarks of CCS Inc.

Notes

- To ensure proper and safe use of the product, please read the Instruction Guide completely before using the product.
- The design and specifications of this product are subject to change without notification for the purpose of product improvement.

 **CCS Inc.**

Headquarters (Kyoto, Japan)
TEL: +81-75-415-8284, FAX: +81-75-415-8316
E-mail: sales@ccs-inc.co.jp
<http://www.ccs-grp.com/>

CCS Asia PTE. LTD. (Singapore)
TEL: +65-6363-1180, FAX: +65-6363-1236
E-mail: sales@ccs-asia.com.sg
<http://www.ccs-asia.com.sg/>

CCS China Inc. (Shenzhen)
TEL: +86-755-8279-0477, FAX: +86-755-8279-0478
E-mail: ccschina@ccs-inc.co.jp
<https://www.ccs-chn.com>

CCS America, Inc. (USA)
TEL: +1-781-272-6900, FAX: +1-781-272-6902
E-mail: info@ccsamerica.com
<https://www.ccsamerica.com/>

CCS MV (Thailand) Co., Ltd.
TEL: +66-(0)2-779-1051, FAX: +66-(0)2-779-1054
E-mail: sales@ccs-asia.com.sg
<http://www.ccs-asia.com.sg/>

Taiwan Office
TEL: +886-2-2581-7676, FAX: +886-2-2581-7662
E-mail: taiwan-tr@ccs-inc.co.jp

CCS Europe N. V. (Belgium)
TEL: +32-(0)2-333-0080, FAX: +32-(0)2-333-0081
E-mail: info@ccseu.com

CCS MV (Malaysia) Sdn. Bhd.
TEL: +604-611-6656
E-mail: sales-msia@ccs-asia.com.sg
<http://www.ccs-asia.com.sg/>

CCS KOREA Inc.
TEL: +82-31-360-3656
E-mail: ccskorea@ccs-inc.co.jp