

# TR-RC120 LED Lighting Controller

Issue 009



User manual

## Copyright and disclaimer notice

Except as prohibited by law:

All hardware, software and documentation is provided on an 'as is' basis. This information is for guidance only. Installers must perform their own risk assessment specific to each installation.

It is essential that the users ensure that the operation of the product is suitable for their application.

The users must ensure that incorrect functioning of this equipment cannot cause any dangerous situation or significant financial loss to occur.

Deliberate acts of endangerment and vandalism are not covered by this document and must be considered by the installer.

While care has been taken in the preparation of this document Gardasoft Vision Ltd will not accept any liability for consequential loss of any kind except those required by law.

All trademarks acknowledged. This document is Copyright - 2021 Gardasoft Vision Ltd.

## EC conformity declaration

The EC Certificate of Conformity is available from Gardasoft Vision Ltd on request  
Issue status of this document: Issue 0067 (September 2021)

---

---

# Contents

<b>1</b>	<b>Getting started</b>	<b>5</b>
1.1	TR-RC120 features - a summary	5
1.2	GigE Vision™	5
<b>2</b>	<b>Safety precautions</b>	<b>6</b>
2.1	Heat	6
2.2	Electrical	6
2.3	General	6
2.4	Installation guidance (disclaimer)	7
<b>3</b>	<b>Sicherheitsvorkehrungen</b>	<b>7</b>
3.1	Hitze	7
3.2	Elektrik	7
3.3	Allgemeines	8
3.4	Haftungsausschluss	8
<b>4</b>	<b>Mesures de sécurité</b>	<b>8</b>
4.1	Chaleur	8
4.2	Électricité	9
4.3	Général	9
4.4	Clause de non-responsabilité	9
<b>5</b>	<b>Mounting the TR-RC120</b>	<b>9</b>
5.1	Environmental considerations	10
<b>6</b>	<b>Connecting the TR-RC120</b>	<b>10</b>
6.1	Power	11
6.2	Lighting output	11
6.3	Trigger input	11
6.4	Ethernet	12
6.5	Connectors (general)	12
<b>7</b>	<b>General description</b>	<b>13</b>
7.1	Pulse and duty cycle limits	13
7.2	Triggering	14
7.2.1	<i>Trigger input options</i>	14
7.2.2	<i>Internal trigger</i>	15
7.3	SafeSense	15
7.4	SafePower	16
7.5	Light characterisation	16
7.6	Current adjust	16
7.7	Flags	17
7.8	Fault detection	17

---

---

7.9	Factory settings	17
<b>8</b>	<b>Ethernet address</b>	<b>18</b>
8.1	IP address	18
8.1.1	<i>DHCP</i>	19
8.1.2	<i>Fixed IP address</i>	19
8.2	Automatic sensing	19
<b>9</b>	<b>Web page configuration</b>	<b>20</b>
9.1	Main page	20
9.2	Configuration page	20
9.3	General setup page	22
<b>10</b>	<b>Configuration commands</b>	<b>22</b>
10.1	Lighting setup	22
10.2	Front panel commands	23
10.2.1	<i>Startup</i>	23
10.2.2	<i>Setting the light rating</i>	24
10.2.3	<i>Setting up continuous output</i>	24
10.2.4	<i>Setting up switched output</i>	25
10.2.5	<i>Setting up pulsed operation</i>	26
10.2.6	<i>Setting time periods</i>	27
10.2.7	<i>Setting the internal trigger timer</i>	27
10.2.8	<i>Using the key lock</i>	28
10.2.9	<i>Viewing the trigger status</i>	29
10.2.10	<i>Viewing the output current</i>	29
10.3	Ethernet commands	30
10.3.1	<i>Ethernet communication</i>	30
10.3.2	<i>Command structure</i>	30
10.3.3	<i>General commands</i>	32
10.3.4	<i>Lighting commands</i>	35
10.4	Command summary	37
<b>11</b>	<b>TR-RC120 reference information</b>	<b>38</b>
11.1	Specifications and ratings	38
11.2	Restrictions	39
11.2.1	<i>Continuous mode</i>	39
11.2.2	<i>Switched mode</i>	39
11.2.3	<i>Pulse mode</i>	39
11.3	Event codes	39
11.4	Error codes	40

---

## 1 Getting started

Before you use this product, make sure that you have read and understood Section 2, "Safety precautions" (oder Abschnitt 3, "Sicherheitsvorkehrungen", ou Section 4, "Mesures de sécurité") and Section 11, "TR-RC120 reference information", and that you have checked the TR-RC120 fulfils your requirements.

**Mount** the TR-RC120 (see Section 5, "Mounting the TR-RC120") and **connect** it up as required (see Section 6, "Connecting the TR-RC120").

**Set up** the TR-RC120 for the desired operation as described in Section 10, "Configuration commands", or Section 10.2, "Front panel commands".

We recommend that you visit [www.gardasoft.com](http://www.gardasoft.com) for application notes on this range of products.

There is also a support web page there, which has information on trouble-shooting problems.

### 1.1 TR-RC120 features - a summary

The TR-RC120 product is a single channel LED lighting controller for use in machine vision applications. It can deliver 2A in pulse mode.

The TR-RC120 has Ethernet connectivity and may be controlled through its own web pages and, using trinit<sup>™</sup> technology, allows the control of your illumination system (if it is trinit<sup>™</sup> enabled).

The TR-RC120 automatically senses and sets up trinit<sup>™</sup> enabled lights on connection. It has SafeSense<sup>™</sup> which allows the controller to automatically sense the characteristics of your lights which are not trinit<sup>™</sup> enabled. The TR-RC120 also has SafePower<sup>™</sup> which ensures low heat dissipation and the ability to deliver higher currents with no need for heat sinking.

### 1.2 GigE Vision<sup>™</sup>

The TR-RC120 is GigE Vision compatible. This means that any compatible GigE Vision client image processing software allows the user to view and change controller settings. GigE Vision is an industry standard protocol running on Ethernet which provides easy configuration and control of cameras and other devices.



The TR-RC120 is the first non-streaming device to become available (at the time of writing), so some packages may not support non--streaming devices yet. If your package does not work with the TR-RC120, then please inform the manufacturer or Gardasoft.

## 2 Safety precautions

Read this before using the TR-RC120. Always observe the following safety precautions. If in doubt, contact Gardasoft Vision Ltd. The following symbols are used in this guide:



**Warning:** Read the instructions to understand the possible hazards.



**Warning:** Surface may get hot.



**Warning:** Possible hazardous voltage.

Where these symbols appear in the manual, refer to the text for the precautions to be taken.

### 2.1 Heat



Ensure the TR-RC120 is mounted correctly (see Section 5, “Mounting the TR-RC120”), and that you do not exceed any of the ratings for the unit (see Section 11.1, “Specifications and ratings”).

At its maximum ratings, the TR-RC120’s enclosure can exceed 65°C which is sufficient to cause a burn if touched. Place in a position where personnel cannot accidentally touch it and ensure there is a free flow of air around the unit.

### 2.2 Electrical



The TR-RC120 produces high energy pulses. Take care to connect the outputs correctly and protect the output wiring and load from any short-circuits. When switched off, energy remains stored in the TR-RC120 for about 15 seconds.

The TR-RC120 does not have complete tracking isolation of input and output.

Transients caused by inductive loads must be suppressed externally to the TR-RC120.

**Warning:** This is a Class A product. Its use in residential areas may cause radio interference, and such use should be avoided unless special measures are taken by the user to restrict emissions to a level that allows the reception of broadcast transmissions.

### 2.3 General



The TR-RC120 must not be used in an application where its failure could be a danger to personal health or damage to other equipment.

If the equipment is used in a manner not specified by the manufacturer, the protection provided by the equipment may be impaired.

## 2.4 Installation guidance (disclaimer)

This information is for guidance only. Installers must perform their own risk assessment specific to each installation. While Gardasoft Vision Ltd has taken every care in the preparation of this advice, Gardasoft Vision Ltd accepts no liability for damages of any kind except those required by law.

Deliberate acts of endangerment and vandalism are not covered by this document and must be considered by the installer.

## 3 Sicherheitsvorkehrungen

Bitte lesen Sie dieses Dokument, bevor Sie die TR-RC120 verwenden. Beachten Sie immer die folgenden Sicherheitshinweise. Bei Fragen wenden Sie sich an Gardasoft Vision Ltd. Die folgenden Symbole werden in dieser Anleitung verwendet:



**Warnung:** Lesen Sie die Hinweise, um eine mögliche Gefahr zu verstehen.



**Warnung:** Oberfläche kann heiß werden.



**Warnung:** Mögliche gefährliche Spannung.

Wenn diese Symbole in dieser Anleitung erscheinen, finden Sie im beistehenden Text die zu ergreifenden Vorsichtsmaßnahmen.

### 3.1 Hitze



Stellen Sie sicher, dass die TR-RC120 ordnungsgemäß montiert wurde (siehe Abschnitt 5, "Mounting the TR-RC120") und dass Sie keinen der Werte für diese Einheit überschreiten (siehe Abschnitt 11.1, "Specifications and ratings").

Bei ihren Maximalwerten kann das Gehäuse der TR-RC120 mehr als 65°C erreichen und folglich bei Berührung Verbrennungen verursachen. Positionieren Sie sie an einem Ort, an dem sie nicht aus Versehen von Personal berührt werden und an dem die Luft um die Einheit zirkulieren kann.

### 3.2 Elektrik



Die TR-RC120 produziert energiereiche Pulse. Achten Sie darauf, die Ausgänge korrekt anzuschließen und die Ausgangsverdrahtung und die Verbraucher vor Kurzschlüssen zu schützen. Nach dem Ausschalten wird die Energie noch etwa 15 Sekunden lang in der TR-RC120 gespeichert.

Die TR-RC120 verfügt über keine vollständige Nachlauf-Isolierung des Einund Ausgangs.

Spannungsspitzen am TR-RC120 aufgrund von induktiven Ladungen müssen extern unterdrückt werden.

**Warnung:** Dies ist ein Produkt der Klasse A. Es kann bei Benutzung im Wohnbereich Funkstörungen verursachen. Aus diesem Grund wird von einer derartigen Nutzung abgeraten, sofern vom Benutzer keine besonderen Maßnahmen ergriffen wurden, um die Emissionen auf ein Niveau zu begrenzen, das den Empfang von Rundfunksendungen erlaubt.

### 3.3 Allgemeines



Die TR-RC120 darf nicht in Bereichen verwendet werden, in denen bei Ausfall eine Gefahr von Personen- oder Sachschäden besteht. Wenn das Gerät nicht entsprechend den Herstellerangaben eingesetzt wird, kann der durch das Gerät bereitgestellte Schutz beeinträchtigt werden.

### 3.4 Haftungsausschluss

Diese Angaben dienen lediglich der Orientierung. Der Monteur muss für jede Installation eine eigene spezifische Risikobewertung durchführen. Gardasoft Vision hat bei der Zusammenstellung dieser Empfehlungen größtmögliche Sorgfalt walten lassen. Gardasoft Vision übernimmt über das gesetzlich erforderliche Maß hinaus keine Haftung für Schäden aller Art.

Vorsätzliche Gefährdungen und Vandalismus werden von diesem Dokument nicht abgedeckt und sind vom Monteur zu berücksichtigen.

## 4 Mesures de sécurité

Veillez lire la notice avant d'utiliser le TR-RC120. Respectez toujours les mesures de sécurité qui suivent. En cas de doute, contactez Gardasoft Vision Ltd. Les symboles suivants sont utilisés dans ce manuel:



**Attention:** Lisez les instructions pour comprendre quels sont les risques éventuels.



**Attention:** La surface peut devenir chaude.



**Attention:** Risque d'électrocution.

Veillez vous référer aux consignes du manuel pour connaître les précautions à suivre au regard de ces symboles.

### 4.1 Chaleur



Assurez-vous que le TR-RC120 est monté correctement (voir Section 5, "Mounting the TR-RC120") et que vous ne dépassez pas les charges pour l'unité (voir Section 11.1, "Specifications and ratings").

À ces charges maximales, le boîtier du TR-RC120 peuvent dépasser 65°C, ce TR-RC120 qui est suffisant pour occasionner des brûlures en

cas de contact. Assurez-vous que le personnel ne peut pas y toucher accidentellement et que l'air circule autour de l'unité.

## 4.2 Électricité



Le TR-RC120 produit de fortes pulsations énergétiques. Assurez-vous que les sorties sont bien connectées et que les fils de sortie et les charges sont bien à l'abri d'éventuels courts circuits. Une fois l'appareil éteint, l'énergie résiduelle reste stockée dans le TR-RC120 pendant environ 15 secondes.

Le TR-RC120 ne dispose pas de système complet d'isolation des entrées et sorties.

Les transitoires causés par les charges inductives doivent être supprimés à l'extérieur du TR-RC120.

Attention : Ce produit est de catégorie A. Son utilisation en zone résidentielle peut causer des interférences radio, et devra alors être évitée sauf si des mesures spéciales ont été prises par l'utilisateur pour restreindre les émissions à un niveau permettant la réception des transmissions radiodiffusées.

## 4.3 Général



Le TR-RC120 ne doit pas être utilisé dans une situation où toute panne de celui-ci mettrait en danger la santé des personnes ou risquerait d'endommager d'autres équipements.

Si l'appareil est utilisé d'une manière différente de celle recommandée par le fabricant, la protection offerte par l'appareil pourra en être altérée.

## 4.4 Clause de non-responsabilité

Ces informations sont seulement à titre indicatif. Les installateurs doivent établir leur propre évaluation de risques pour chaque installation. Gardsoft Vision a préparé minutieusement ces conseils, mais Gardasoft Vision décline toute responsabilité concernant les dommages de toute nature à l'exception de ceux requis par la loi.

Les actes malveillants d'endommagement et de vandalisme ne sont pas couverts par ce document et doivent être pris en compte par l'installateur.

## 5 Mounting the TR-RC120

Mount the TR-RC120 unit vertically or horizontally on the DIN rail to allow the display to be read easily (see overleaf).

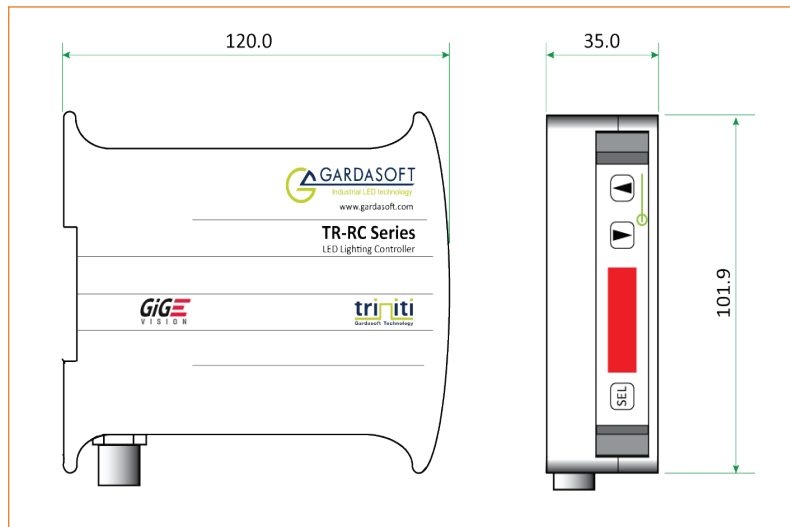

## 5.1 Environmental considerations

If the average output power exceeds 15W, the TR-RC120 must be mounted vertically to allow air to pass through it. Leave 25mm clear either side of the TR-RC120 to aid cooling.

The TR-RC120 has an ingress rating of IP20 and it should be sited so that water or dirt cannot enter the unit.

## 6 Connecting the TR-RC120

Refer to Section 11, RC1xx reference information for the ratings of the connections. The TR-RC120's connections are shown below:

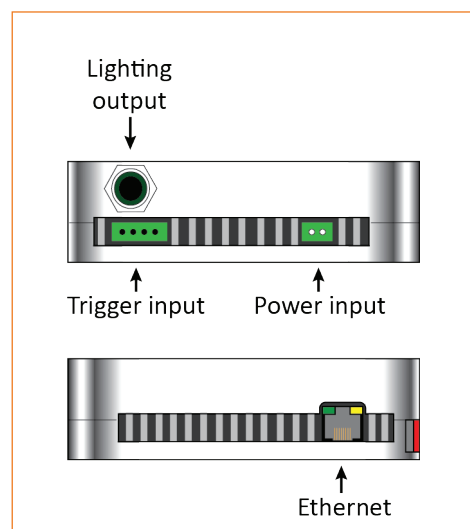

## 6.1 Power

Any power supply derived from mains electricity must have a Safety Extra Low Voltage (SELV) output. Route low voltage wiring to the TR-RC120 controller separately from mains electricity wiring. If this is not possible, make sure the low voltage wiring has an insulation rating that is appropriate or supplementary insulation is used. The connections are shown below:

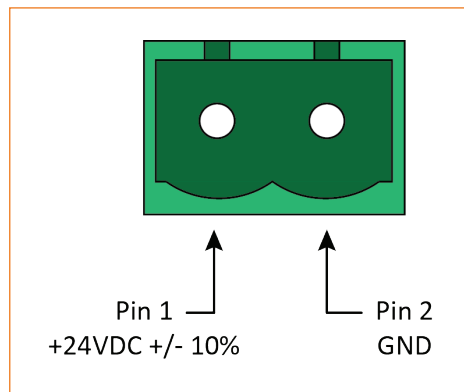

## 6.2 Lighting output

The lighting output socket incorporates the trinito sense lines. Before you connect a light that is not trinito enabled to the output, ensure you have set the current or voltage rating for the light. See Section 10.1, "Lighting setup" for more information about this.

The lighting output connections and trinito sense lines must not be commoned to any other controllers or grounded in any way. The connections are shown below:

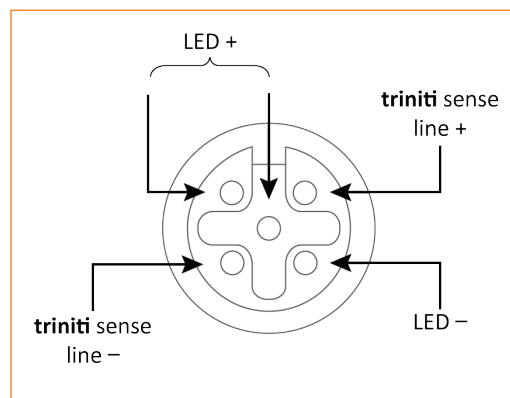

## 6.3 Trigger input

The trigger input is a Smart Input; it accepts a range of trigger sources with minimal extra circuitry. Refer to Section 7.2.1, "Trigger input options" for further information.

**Note:** The Smart Input is not isolated, it is ground referenced to the power supply negative connection.

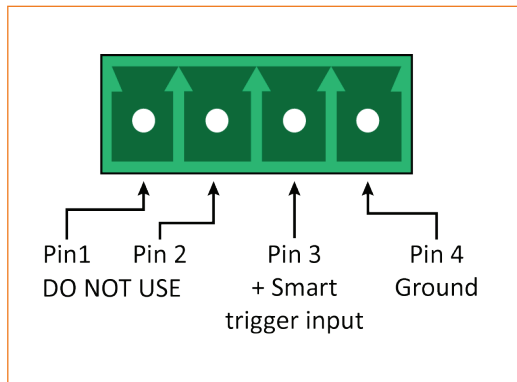

In operating environments where there is a high level of radiated electrical noise, use a shielded cable for the trigger input as shown below:

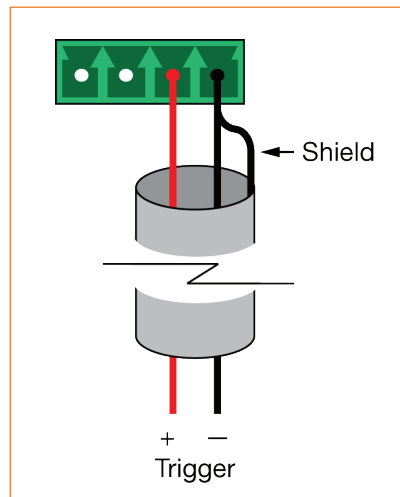

## 6.4 Ethernet

The RJ45 connector fitted to the TR-RC120 requires a straight-through cable to connect to a network switch, hub or router. The connection is 10Base-T and operates at 10Mbits per second.

## 6.5 Connectors (general)

The connectors required to mate with the TR-RC120 controller's connectors are as follows:

Connector	Description	Supplier/Part number
Power input	Würth 351 series 2 way screw terminal free socket	Würth 69135100002 Farnell 164-1952 Newark 19P1467
Trigger input	Würth 361 series 4 way screw terminal free socket	Würth 69136110004 Farnell 184-1351 Newark 16T1571

Connector	Description	Supplier/Part number
Lighting output	TE Connectivity M12 5 pole straight cable mount circular connector, male contacts	TE 1838277-3 RS 669-3412

## 7 General description

Three modes of operation are provided for the light output:

**Continuous** – the output is constant, but variable between 0% and 100% in steps of 0.1%.

**Pulse (strobe)** – the output is pulsed once per trigger. The delay from trigger to pulse, the pulse duration and the brightness can all be set.

**Switched** – the trigger input can be used to switch the output current on and off.

The set-up is non-volatile, so the TR-RC120 resumes the same operation after a power cycle.

### 7.1 Pulse and duty cycle limits

The output is off by default. Upon being triggered, the TR-RC120 pulses to the output after a delay. The delay, pulse width, re-trigger delay, and pulse intensity are all configurable (see Section 9, “Web page configuration”, or Section 10.3.4, “Lighting commands”, or Section 10.2, “Front panel commands”).

In pulse and switched modes, the brightness can be set up to 1000% of its rating for short periods and low duty cycles. To avoid damage to the lighting, the TR-RC120 limits the duty cycle by ignoring triggers that are too soon after the previous trigger. The maximum pulse width and duty cycles are shown below:

Output brightness	Maximum pulse width	Maximum duty cycle
0 to 100%	100ms	100%
101% to 200%	30ms	30%
201% to 300%	10ms	20%
301% to 500%	2ms	10%
501% to 1000%	1ms	5%

So for example, if the brightness is set to 250%, then the TR-RC120 does not allow pulses greater than 10ms long. With 10ms pulses, any trigger

occurring within the next 50ms is ignored as the duty cycle would be greater than 20%.

The TR-RC120 pulsed current cannot exceed 2.0A, so for a lighting rating of 0.2A, 1000% brightness is possible. For 0.5A lighting rating the maximum brightness is 400%.

## 7.2 Triggering

Trigger pulses should have a minimum pulse width of 2µs. You can set the sense of the TR-RC120 trigger input. Do this by setting the P flag from the front panel (see Section 10.2, “Front panel commands”), the web page (see Section 9, “Web page configuration”) or the **RE** command (see Section 10.3.3, “General commands”). The effect of setting the P flag is summarised below:

Mode	Flag state	Effect
Continuous	Unused	Output is on.
Switched	P Flag = 1	Output is <b>off</b> when trigger is off. Output is <b>on</b> when trigger is on.
	P Flag = 0	Output is <b>on</b> when trigger is off. Output is <b>off</b> when trigger is on.
Pulsed	P Flag = 1	Pulse is triggered on rising edge.
	P Flag = 0	Pulse is triggered on falling edge.

**Note:** The P Flag inverts the sense of the trigger.

### 7.2.1 Trigger input options

You can connect the following types of trigger to the Smart Input:

#### 3V to 24V voltage source

Any voltage between 0V and 0.9V is taken as logic 0.

Any voltage between 3V and 24V is taken as logic 1.

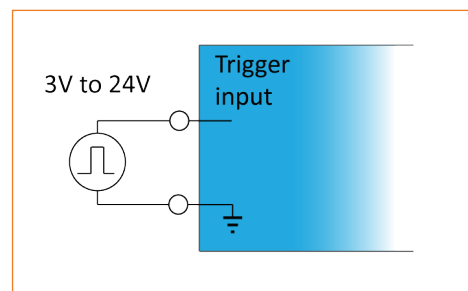

#### TTL signal

You can connect a TTL signal to the TR-RC120's input. However, a 3.3V TTL signal only works if it can drive 8kΩ without dropping below 2.7V.

If the P flag is set to '1', the TR-RC120 output turns on when the TTL driver goes HIGH. To reverse this, set the P flag to '0' (see Section 7.2, “Triggering”).

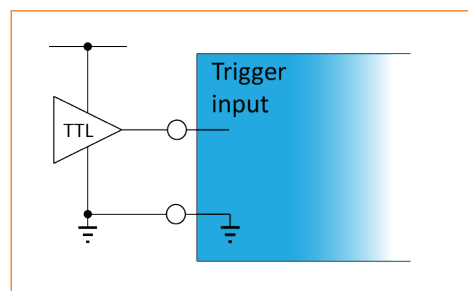

### NPN signal

You can connect an NPN open collector drive to the TR-RC120's input. Use the connections shown opposite.

If the P flag is set to '1', the TR-RC120 output turns on when the driving transistor turns on. To reverse this, set the P flag to '0' (see Section 7.2, "Triggering").

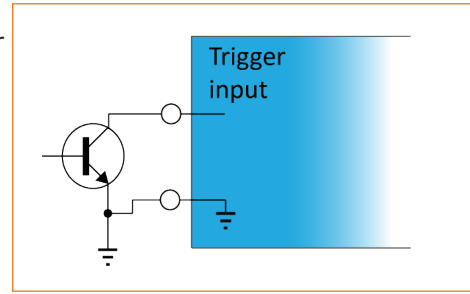

### Opto-coupler

You can connect an opto-coupler as an NPN drive to the TR-RC120's input. This prevents a 'ground-loop' and reduces spurious triggering in high-interference environments.

If the P flag is set to '1', the TR-RC120 output turns on when the driving transistor turns on. To reverse this, set the P flag to '0' (see Section 7.2, "Triggering").

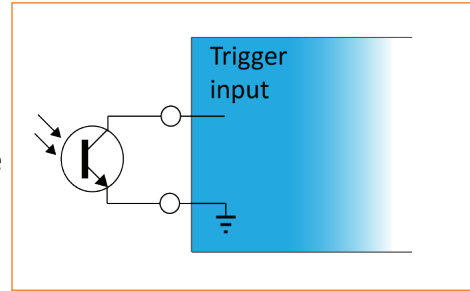

### PNP signal

You can connect a PNP open collector drive to the TR-RC120's input. Use the connections shown opposite. The PNP transistor should not pull up to more than 24V.

If the P flag is set to '1', the TR-RC120 output turns on when the driving transistor turns on. To reverse this, set the P flag to '0' (see Section 7.2, "Triggering").

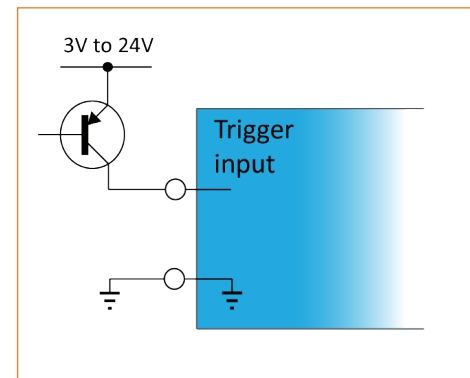

## 7.2.2 Internal trigger

You can set the TR-RC120 to generate its own trigger pulses. The period of these pulses can be set in increments of 100µs from approximately 10ms to 5000ms.

You can set the RC1xx to produce a single pulse for testing purpose. This is set by either a **TR1** command (see Section 10.3.3, "General commands") or using the web page Trigger button (see Section 9, "Web page configuration").

## 7.3 SafeSense

The SafeSense feature of the TR-RC120 operates automatically. After setting the rating for the light, the TR-RC120 senses the light on connection for its type and characteristics. The unit does not need to sense the light

again unless the light has changed or the TR-RC120 has been power-cycled.

For further information on this feature, see the application note, APP936 – SafeSense Technology, available from [www.gardasoft.com](http://www.gardasoft.com).

## 7.4 SafePower

The TR-RC120's SafePower needs no intervention from the user for its operation. The advantages of SafePower are:

- » Heat dissipation in the controller is very low
- » The load voltage can be higher than the supply voltage
- » High continuous currents can be output with a reduced need for heatsinking

For further information on this feature, see the application note, APP966 – SafePower Technology, available from [www.gardasoft.com](http://www.gardasoft.com).

## 7.5 Light characterisation

You can reduce the time it takes for your TR-RC120 controller to reach high accuracy in time-critical machine vision systems when changing from one overdrive brightness setting to another. This can be done by instructing the controller to make current and voltage measurements up to a customer specified brightness limit when the light is characterised. This is called the characterisation limit. The measured overdrive voltage and current relationship is stored in the TR-RC120 and allows it to respond much more rapidly to new overdrive parameters up to that limit.

When a light is detected, the characteristics of the light are measured up to the brightness set for the characterisation limit. It is not essential to set this value and it can be left at 200 (meaning 200% brightness). The feature can also be turned off by setting this value to 0.

You can change the characterisation limit brightness through the TR-RC120's web pages (see Section 9, "Web page configuration") or by command (see Section 10.3.4, "Lighting commands").

## 7.6 Current adjust

The current adjust feature provides a more accurate and repeatable output current. After setting an output current, the controller continually measures the actual current and adjusts the output to maintain the target current. This will compensate for any inaccuracies such as temperature drift in the controller.

If the output current is less than 100mA, the adjustments the feature imposes can have a significant effect on the lighting brightness. If some flickering is seen, it is recommended that the current adjust feature is turned off.

Current adjust can be turned on and off from the TR-RC120's web pages (see Section 9, "Web page configuration") or by using the **RE** command (see Section 10.3.3, "General commands").

## 7.7 Flags

You can set flags on the TR-RC120 controller to alter its operation. They can be set from the unit's front panel, the web page or through the **RE** command (see Section 10.3.3, "General commands"). The following configuration flags are available:

**E Flag** – Enables or disables fault detection. Error checking is enabled as the default setting.

**P Flag** – Sets the trigger input active high or active low. The default setting is active high. Refer to Section 7.2.1, "Trigger input options" for a detailed description of the settings.

**S Flag** – Sets the SafeSense feature of the TR-RC120. When cleared it removes the SafeSense light detection and the controller assumes a light is connected. The default setting is for SafeSense to be enabled. This flag cannot be used when the light is set according to its voltage rating. The S flag cannot be changed from the TR-RC120's front panel.

## 7.8 Fault detection

The TR-RC120 can detect a range of errors when connected to a light. The displayed error codes are shown below with their reasons.

Error	Reason
<b>PO</b>	Internal power dissipation too high. Output turned off.
<b>OP</b>	Output current to lighting is too low. The light is open circuit or there is not enough supply voltage for the requested current.
<b>Sh</b>	Output voltage is too low. The TR-RC120 detects that the output is short-circuited.
<b>HI</b>	The voltage required for the lighting has increased too much. Check for ageing of the light or a failed LED.
<b>LO</b>	The voltage required for the lighting has decreased too much. Check for ageing of the light or a failed LED.

**Note:** When the output current falls below 100mA, some fault detection is disabled. Press **SEL** to cancel the error and allow the TR-RC120 to sense the light again.

## 7.9 Factory settings

You can clear the TR-RC120 configuration to return it to its factory settings: The lighting rating is cleared and the light does not illuminate.

Clear the configuration from the front panel by pressing and holding **SEL** and ▼ for about 5 seconds, until **COL** is displayed. You can also clear the

configuration by using the **CL** command (see Section 10.3.3, “General commands”).

You can start the TR-RC120 from a powered down state (cold boot) with the front panel keypad locked; this process removes the keypad lock.

## 8 Ethernet address

You may need to ask your network administrator for advice about setting up the Ethernet connection.

The application note APP923 – Troubleshooting Ethernet problems is available from [www.gardasoft.com/Downloads](http://www.gardasoft.com/Downloads).

The Ethernet set up of the TR-RC120 is not affected by cold-booting the controller.

### 8.1 IP address

The TR-RC120 needs an Internet Protocol (IP) address to communicate over Ethernet. There are two ways to get an IP address; either programmed into the unit or using DHCP.

For DHCP mode, the TR-RC120 acquired its IP address, subnet mask, and gateway address from the DHCP server. Otherwise the RC120 has a fixed IP address, subnet mask, and gateway address.

DHCP mode or the IP address can be set or read using the GardasoftMaint program available from [www.gardasoft.com](http://www.gardasoft.com).

The GardasoftMaint window is shown below:

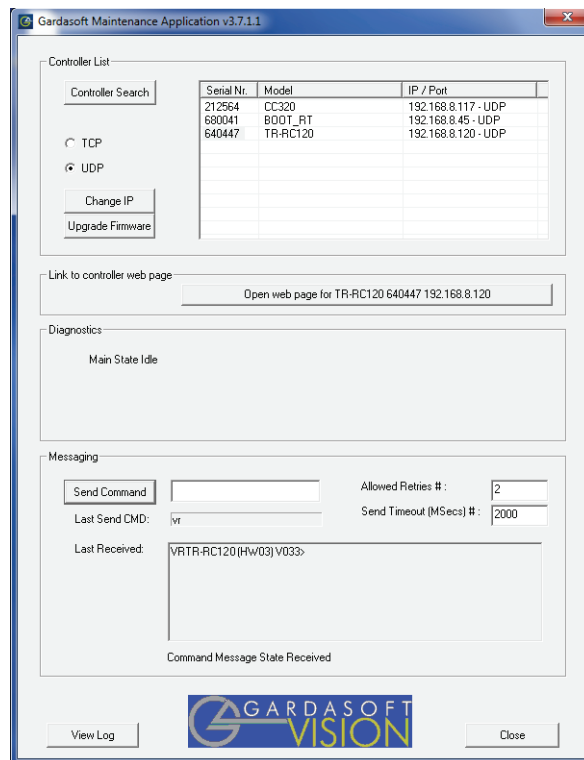

GardasoftMaint allows you to view the controllers on your network, change their IP addresses and upgrade their firmware if it becomes necessary. In the messaging section of GardasoftMaint, you can communicate with your controller using the commands explained in Section 10.3.3, “General commands” and Section 10.3.4, “Lighting commands”. You can also open the selected controller’s web pages at the click of a button. For more information about the TR-RC120’s web pages, see Section 9, “Web page configuration”.

### 8.1.1 DHCP

Most networks use a DHCP server. If there is a PC on the network, you may be able to find out whether a PC on the same network uses DHCP as follows:

- i. Right-click the Windows 10™ icon at the left of your PC’s task bar.
- ii. Select **Network Connections**.
- iii. in the Status pane, click on **View your network properties**.
- iv. DHCP enabled will be set to ‘yes’ if DHCP is in use.

You can find out what IP address is being used by a PC at any time by following the steps below:

- i. Right-click the Windows 10™ icon at the left of your PC’s task bar.
- ii. Select **Network Connections**.
- iii. In the left hand pane, click on **Ethernet**.
- iv. Click on your network icon under *Ethernet*.

Your IP address will be given as the ‘IPV4 address’.

### 8.1.2 Fixed IP address

When using a fixed IP address, you must ensure that you use an IP address that is not being used by any other device on the network. It is usual to keep the first three numbers of the IP address the same as other devices and to change only the last number. For example, if you have a network consisting of a PC (IP address 192.168.1.35) and two TR-RC120s, they could be allocated addresses 192.168.1.201 and 192.168.1.202.

## 8.2 Automatic sensing

The TR-RC120 sends out a message on three events:

- » On power up,
- » When an IP address is received or renewed by DHCP, and
- » When an enquiry message is received

On the first two events, the message is broadcast. On the third it is a reply to a single IP address.

An enquiry message is a UDP packet from source port 30310, destination port 30311 with the message body 'Gardasoft Search' (8-bit ASCII, 16 characters).

The message output by the TR-RC120 is a UDP packet from source port 30311, destination port 30310. It is formatted as:

```
Gardasoft,TR-RC120,000000,111111111111,22222222
```

(8-bit ASCII, 44 characters), where:

000000 is the serial number of the unit

111111111111 is the MAC address in 6 HEX bytes

22222222 is the IP address in 4 HEX bytes

For example, for TR-RC120 serial number 12345, IP address 192.168.1.103, MAC address 00.0B.75.01.80.99 the packet comprises:

```
Gardasoft,TR-RC120,012345,000B75018099,C0A80167
```

## 9 Web page configuration

You can set up the TR-RC120 through its own internal web pages. After locating your controller on your network, click the **Open webpage...** button in GardasoftMaint to take you directly to the TR-RC120's web pages. You can also type the controller's IP address (displayed in GardasoftMaint) into your web browser, which will display the Main page. GardasoftMaint software is available from [www.gardasoft.com](http://www.gardasoft.com).

### 9.1 Main page

The main page (shown below) is the first to open when you access the TR-RC120's web pages. This gives the controller's hardware and firmware revision levels and the serial number. It also tells you the power being dissipated and the TR-RC120's internal temperature.

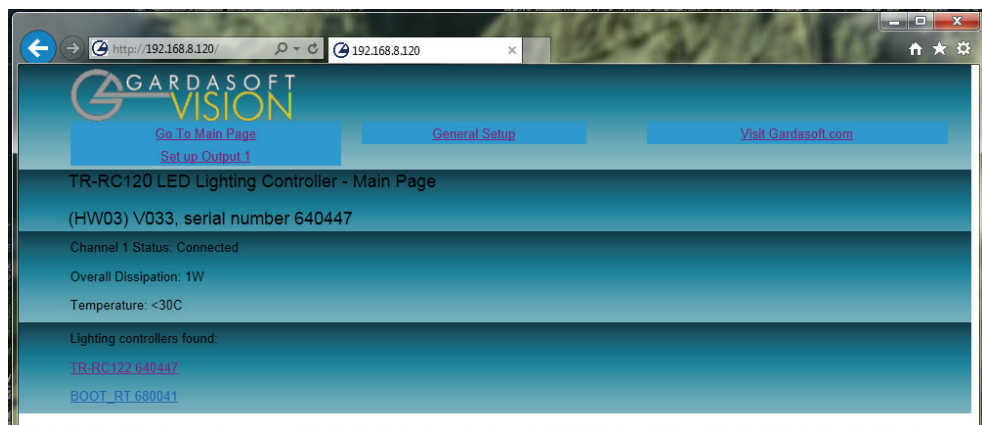

### 9.2 Configuration page

The configuration page allows you to set up the lighting parameters,

view the light data, and view the measurements the TR-RC120 makes during operation. To refresh this page it is important that you click the **Refresh** button on the web page (\*) rather than on your web browser. When configuration changes are submitted, the URL includes the new configuration, so refreshing the page re-submits the URL.

You can set the mode (continuous, pulsed, or switched), the light's brightness and pulse settings. You must click the **Submit** button to effect any changes you make.

Click the **Refresh** button at the bottom of the screen to update the measurements being taken.

The configuration page is shown below:

The screenshot displays the web interface for the TR-RC120 LED Lighting Controller. The browser address bar shows the URL `http://192.168.8.120/channel.c`. The page features the Gardasoft Vision logo and navigation buttons for 'Go To Main Page', 'Set up Output 1', 'General Setup', and 'Visit Gardasoft.com'. The main content area is titled 'TR-RC120 LED Lighting Controller - Channel 1 Configuration' and includes the hardware ID '(HW03) V033, serial number 640447'. The configuration section contains several input fields and checkboxes: Mode (set to 'Continuous'), Trigger (set to 'Trigger 1'), Brightness (%) (50.0), Characterised up to (%) (0.0), Brightness 2 (Selected Mode) (%) (0.0), Pulse Delay (1.000ms), Pulse Width (1.000ms), Retrigger Delay (10.00ms), and Flags (Error Detect, Pos Trigger, Autosense Enabled, and Current adjust, all checked). A 'Submit' button is provided to save changes. Below this is the 'Triniti™ Light Data' section, which lists various parameters such as Triniti Status (Triniti Chip connected), Light Manufacturer (SVL), Light Model (GRD-L300 Red), Light Serial Number (00000), Light Lifetime (0 Hours), Light On Time (0 Hours), Sensor Temperature (25.0°C), Triniti Current Rating (0.500A), Triniti Chip Serial Number (1000000), and Triniti Chip SW Version (100). A 'Submit' button is also present for this section. The final section shows real-time measurements: Status (Connected), Dissipation (1.3W), Measured Current (0.248A), Supply Voltage (24.3V), SafePower(TM) Voltage (16.8V), Lighting Voltage (12.0V), Expected Voltage (11.9V), Voltage Drop (5.3V to 5.2V), Duty Cycle (100.0%), and Trigger Count (0, TRIG1 = 0). A 'Refresh' button is located at the bottom of this section, accompanied by a red asterisk icon.

### 9.3 General setup page

On the general setup page (shown below), you can set a password for the TR-RC120 and send it commands. Refer to Section 10.3.3, “General commands” or Section 10.3.4, “Lighting commands” for the commands you can use to operate the TR-RC120.

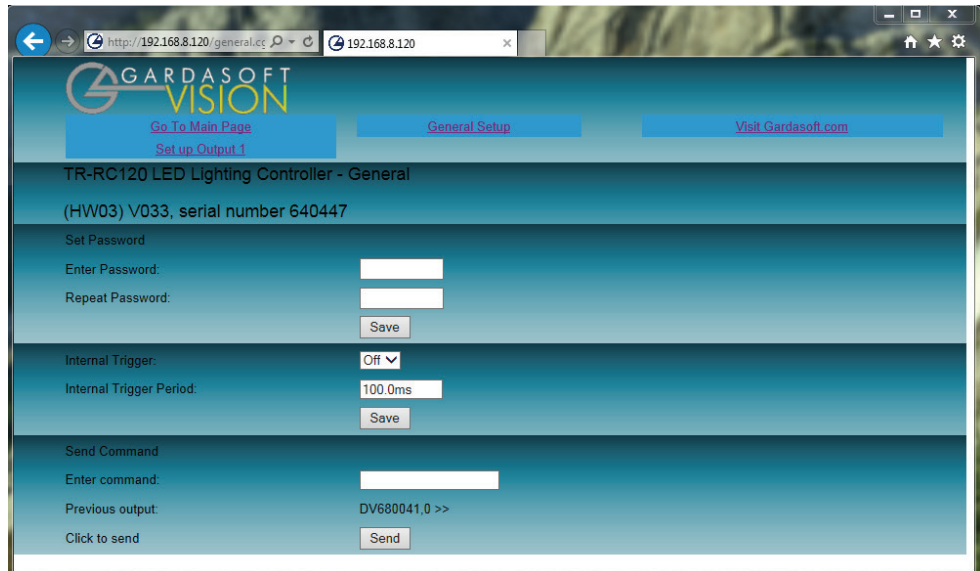

## 10 Configuration commands

In addition to configuring the TR-RC120 using its web page interface, you can configure it from the front panel or using the Ethernet connection. Both of these methods are described in this section along with general information about setting up lights.

### 10.1 Lighting setup

Lighting units have a rating, given in current or voltage, that produces 100% brightness continuously. The TR-RC120 controller is compatible with current or voltage rated lights.

If you connect a trinita enabled light, its ratings are set up by the TR-RC120 automatically. Otherwise you must enter the rating for the light before connecting it to the controller, or if you replace it with a different type of light.

Always consult the labelling on the lamp or the datasheet for its rating. Where a voltage and current rating are quoted, use the voltage to set up the controller. Where a voltage and power rating are quoted, use the voltage rating. In all other cases use the current rating. If the light is not rated, use the current rating from the LED datasheet.

The current rating can be set from 0.01A to 2A in steps of 0.01A. The voltage rating can be set from 12V to 24V in steps of 1V.

When a voltage rated light is connected, the TR-RC120 automatically senses the current rating of the light.

Both voltage and current rated lights are driven with a constant current. This provides better brightness stability and allows the TR-RC120 to prevent the light being over-driven.

## 10.2 Front panel commands

Using the front panel keypad, you can set the configuration, set a key lock code so unauthorised users cannot change any settings, set the internal trigger timer, view trigger status, and set the voltage or current rating.

The TR-RC120 features a protective clear plastic cover over the display and push-buttons. With this cover open, the operation of the unit is unaffected by static discharges up to 2kV. With the protective cover closed, the EMC requirements of EN61326 are fully met. The unit is therefore suitable for initial setting up with the cover open. However, the cover should be closed when in use.

### 10.2.1 Startup

On power-up, the TR-RC120 displays **b** for 5 seconds, followed by **8.8.8** to show the display is working correctly. The product name is then displayed; **TR-**, then **RC1**, and **20**, and then **2** to indicate the maximum current rating. The firmware version number is then displayed, for example **068**, and then the unit is ready for operation.

When the TR-RC120 is not being configured, the display shows the status of the lighting output as shown below:

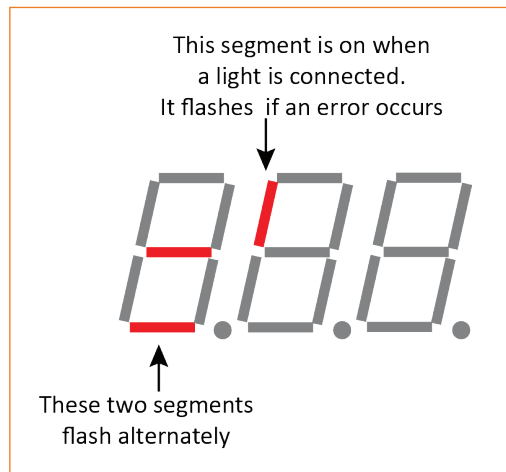

The TR-RC120 displays an error if a light is connected but no rating specified.

To configure the TR-RC120 from the front panel, press and hold **SEL** for 1 second. **CH1** is displayed. You can then use the **▲** and **▼** keys to scroll through the menu, pressing the **SEL** button to access the required set up as shown in the table overleaf:

Display	Select to:
<b>CH1</b>	To set up an output channel.
<b>Eth</b>	Set up Ethernet access.
<b>LOC</b>	Set up a key lock.
<b>tES</b>	Factory test. Do not use.
<b>FrE</b>	Set up the internal trigger.
<b>trg</b>	View the trigger status.
<b>UAL</b>	View the output current.
<b>rAt</b>	Set the lighting rating.

### 10.2.2 Setting the light rating





Press and hold **SEL** for 1 second and follow the keystrokes below:





	<p><b>CH1</b> is displayed. Use the ▲ and ▼ buttons to scroll to <b>rAt</b>.</p>
	<p>Press the <b>SEL</b> button.</p>
	<p>Use the ▲ and ▼ buttons to select the method you require to set the rating of the light: <b>Cur</b> for current and <b>Vol</b> for voltage. Press the <b>SEL</b> button.</p>
	<p>Use the ▲ and ▼ buttons to set the current in Amps and the voltage in Volts. Press the <b>SEL</b> button.</p>
	<p>The light's rating is set up.</p>





### 10.2.3 Setting up continuous output

Press and hold **SEL** for 1 second and follow the keystrokes below:

	<p><b>CH1</b> is displayed. Press the <b>SEL</b> button.</p>
	<p>Use the ▲ and ▼ buttons to select <b>SCo</b> (other options displayed are <b>SPu</b> and <b>SON</b>). Press the <b>SEL</b> button.</p>

    **bri** is displayed. Press the **SEL** button.





    Use the **▲** and **▼** buttons to select the required brightness from 1% to 99%. Press the **SEL** button.





    Use the **▲** and **▼** buttons to set the Error Detect flag: **F E** is enabled, **F-E** is disabled. Press the **SEL** button.





    Continuous output is set up.





### 10.2.4 Setting up switched output





Press and hold **SEL** for 1 second and follow the keystrokes below:





    **CH1** is displayed. Press the **SEL** button.

    Use the **▲** and **▼** buttons to select **SO<sub>n</sub>** (other options displayed are **SP<sub>u</sub>** and **SC<sub>o</sub>**). Press the **SEL** button.

    **bri** is displayed. Press the **SEL** button.

    Use the **▲** and **▼** buttons to select the required brightness from 1% to 999%. Press the **SEL** button.

    Use the **▲** and **▼** buttons to set the Trigger flag: **F P** is enabled, **F-P** is disabled. Press the **SEL** button.

    Use the **▲** and **▼** buttons to set the Error Detect flag: **F E** is enabled, **F-E** is disabled. Press the **SEL** button.

    Switched output is set up.

## 10.2.5 Setting up pulsed operation

Press and hold **SEL** for 1 second and follow the keystrokes below:

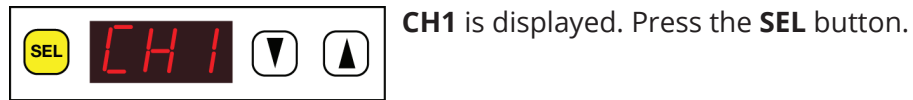

**CH1** is displayed. Press the **SEL** button.

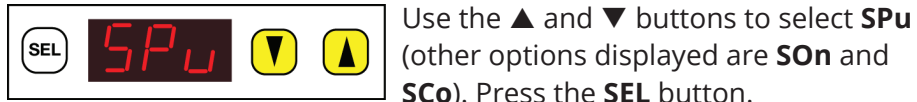

Use the **▲** and **▼** buttons to select **SPu** (other options displayed are **SO<sub>n</sub>** and **SCo**). Press the **SEL** button.

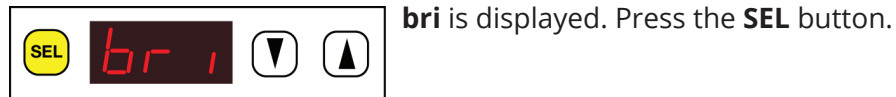

**bri** is displayed. Press the **SEL** button.

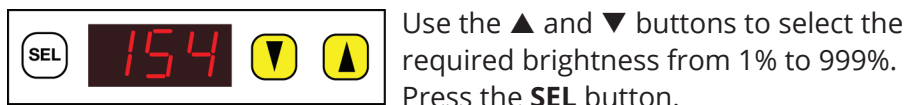

Use the **▲** and **▼** buttons to select the required brightness from 1% to 999%. Press the **SEL** button.

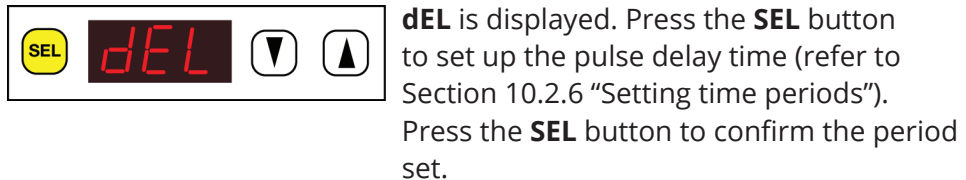

**dEL** is displayed. Press the **SEL** button to set up the pulse delay time (refer to Section 10.2.6 "Setting time periods"). Press the **SEL** button to confirm the period set.

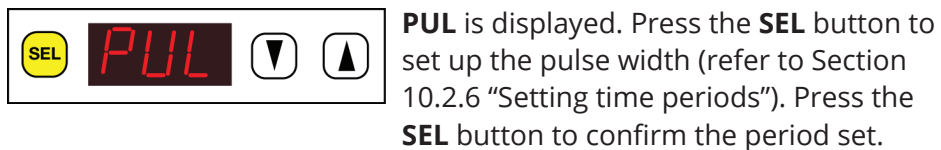

**PUL** is displayed. Press the **SEL** button to set up the pulse width (refer to Section 10.2.6 "Setting time periods"). Press the **SEL** button to confirm the period set.

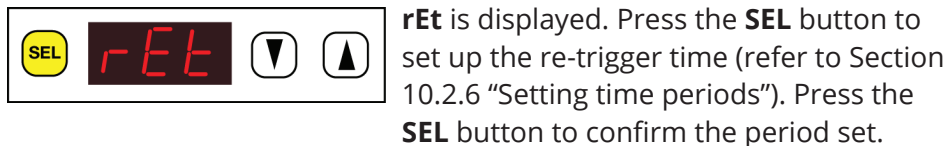

**rEt** is displayed. Press the **SEL** button to set up the re-trigger time (refer to Section 10.2.6 "Setting time periods"). Press the **SEL** button to confirm the period set.

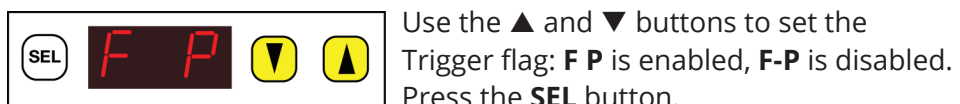

Use the **▲** and **▼** buttons to set the Trigger flag: **F P** is enabled, **F-P** is disabled. Press the **SEL** button.

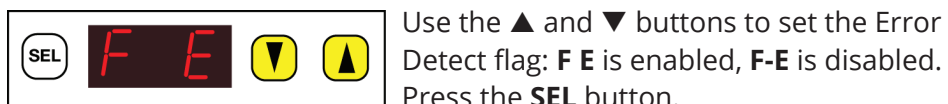

Use the **▲** and **▼** buttons to set the Error Detect flag: **F E** is enabled, **F-E** is disabled. Press the **SEL** button.

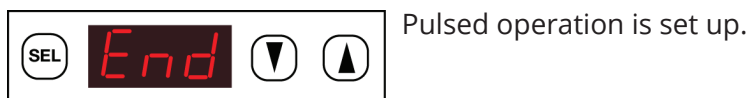

Pulsed operation is set up.

**Note:** If you set the brightness to more than 100%, the pulse width is limited to a safe value as described in Section 7, "General description".

### 10.2.6 Setting time periods

When the TR-RC120 requires you to enter a numeric value, the right hand digit flashes to indicate you can use the ▲ and ▼ keys to change the value.

To set pulse delay, re-trigger and pulse width values a scheme is used where the exponent (power of ten) of the value is set. The exponent values are as follows:

Exponent value	Number format	Range of values
E-2	9.99	Values are displayed in seconds from 10ms to 5 seconds in steps of 10ms.
E-3	999.	Values are displayed in milliseconds from 1ms to 999 ms in steps of 1ms.
E-4	99.9	Values are displayed in milliseconds from 0.1ms to 99.9 ms in steps of 0.1ms.

Follow the keystrokes below to enter numerical data into the TR-RC120 using the scheme shown.



**E-2** is displayed. Press the **SEL** button.



Use the ▲ and ▼ buttons to select the required value in steps of 10ms. Press the **SEL** button.



Use the ▲ and ▼ buttons to scroll to **E-3** to enter time values from 1ms to 999ms. Press the **SEL** button.



Use the ▲ and ▼ buttons to select the required value in steps of 1ms. Press the **SEL** button.



Use the ▲ and ▼ buttons to scroll to **E-4** to enter time values from 0.1ms to 99.9ms. Press the **SEL** button.



Use the ▲ and ▼ buttons to select the required value in steps of 0.1ms. Press the **SEL** button.

### 10.2.7 Setting the internal trigger timer

You can set an internal trigger timer when the TR-RC120 is in pulse mode. When set, the TR-RC120 triggers with the same delay and pulse width already set up as described in Section 10.2.5, "Setting up pulsed operation". External triggering remains enabled.

Ensure the TR-RC120 is set to pulsed operation. To set the period of the internal trigger timer, press and hold **SEL** for 1 second, and follow the keystrokes below:

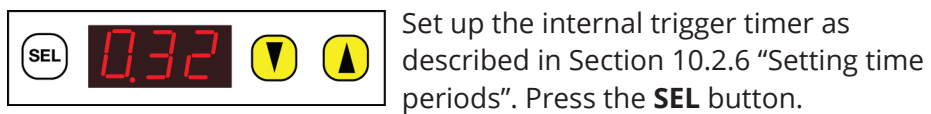
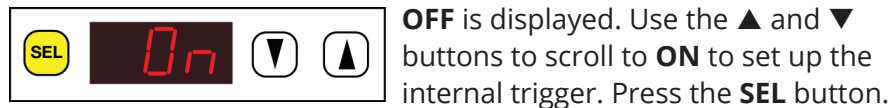
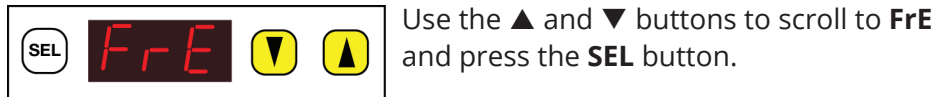
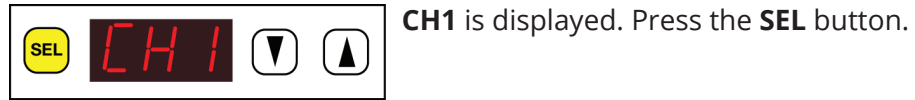

### 10.2.8 Using the key lock

You can lock the TR-RC120 front panel keypad so unauthorised users cannot change the configuration. To do this you can set a numeric code from 0 to 255, which provides moderate protection.

To lock the keypad, press and hold **SEL** for 1 second and follow the keystrokes below:

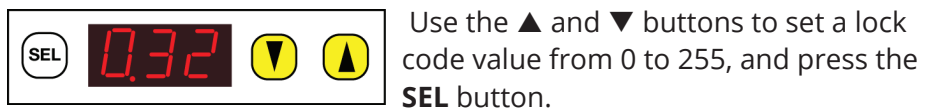
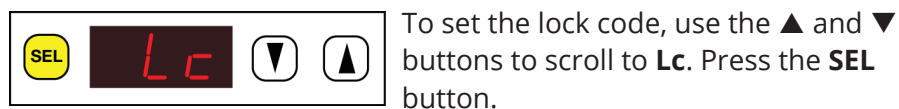
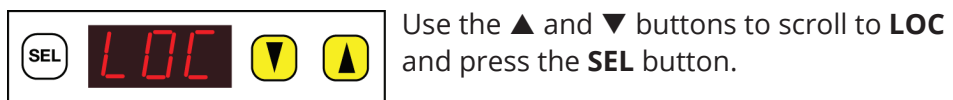
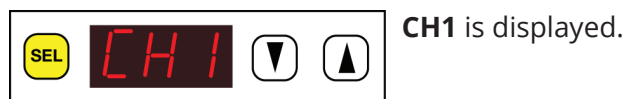

**Note:** Setting a lock code does not prevent a cold boot of the TR-RC120. A cold boot clears the lock code.

To unlock the keypad, press and hold **SEL** for 1 second and follow the keystrokes below:

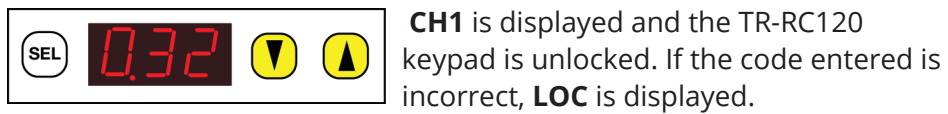
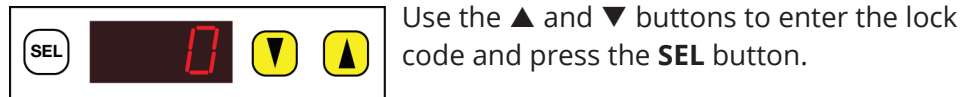
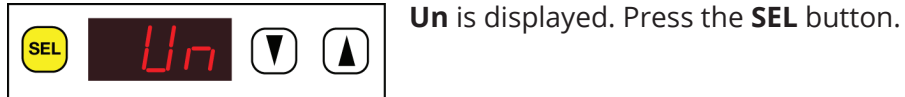

### 10.2.9 Viewing the trigger status

You can view the trigger input status and whether the light is pulsing when the TR-RC120 is set to pulse or switched mode. To do this, press and hold **SEL** for 1 second and **CH1** is displayed. Use the **▲** and **▼** keys to scroll to **trg** and press **SEL**. The display shown below appears:

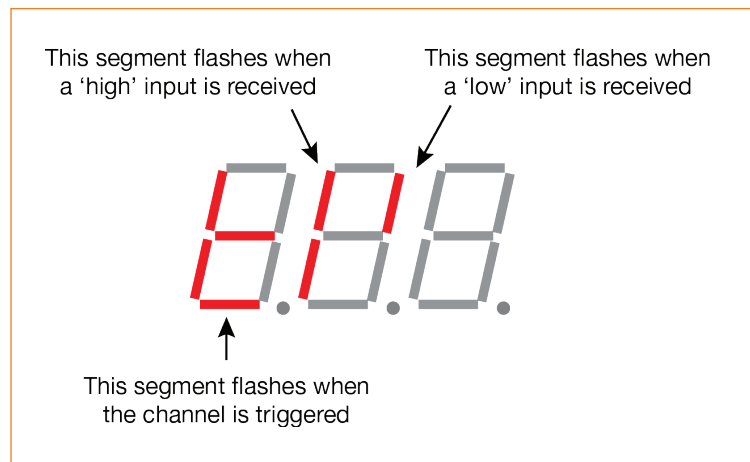

### 10.2.10 Viewing the output current

You can view an approximate measure of the output current from the TR-RC120 front panel. The current measurement is updated roughly once per second, but this can be slower when the TR-RC120 is set to pulsed operation.

To view the output current, press and hold **SEL** for 1 second and follow the keystrokes overleaf:

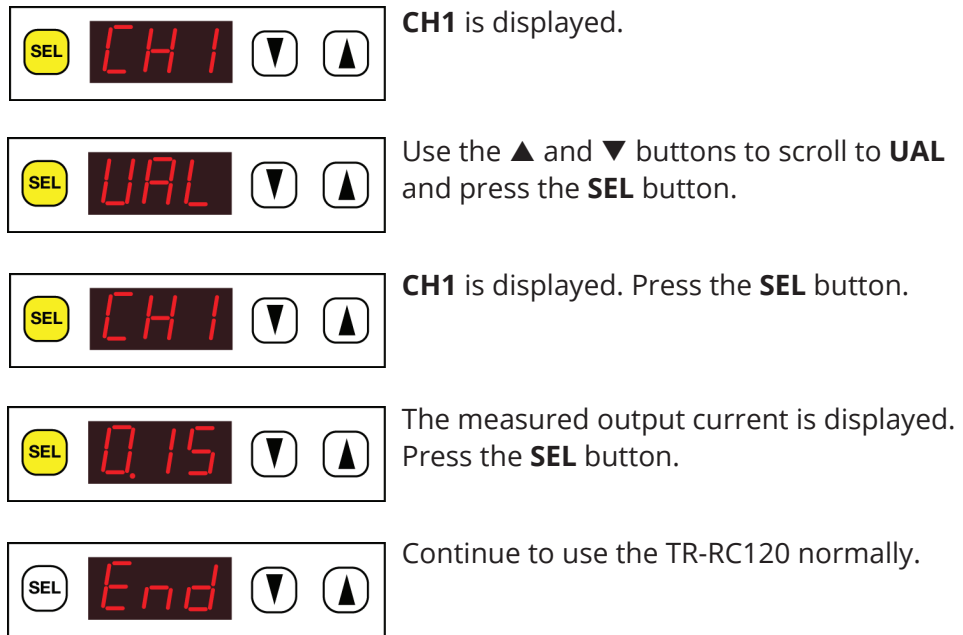

### 10.3 Ethernet commands

You can configure the TR-RC120 through the Ethernet connection using UDP or TCP/IP. You can download GardasoftMaint from [www.gardasoft.com/Downloads](http://www.gardasoft.com/Downloads), which allows you to send commands to configure your TR-RC120.

#### 10.3.1 Ethernet communication

Command lines can be sent from a client using TCP or UDP packets. They should be sent to destination port 30313. The source port can be set to anything, but 30312 is recommended.

Only one TCP connection can be active at any time.

A carriage return (ASCII 13) character should be sent to terminate the command line in case multiple packets get joined together.

#### 10.3.2 Command structure

Commands are sent by the host (a PC connected to the network). The command is returned by the TR-RC120, together with any reply generated by that command, in UDP or TCP/IP packets followed by <LF><CR>.

The last character sent is the > prompt. Once this has been received, the host knows the command has been completed.

For example, sending the **VR** command might get the reply below:

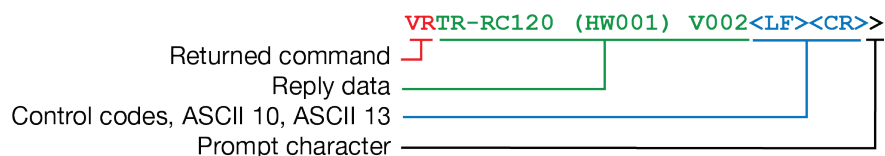

If there is an error, a typical reply might be:

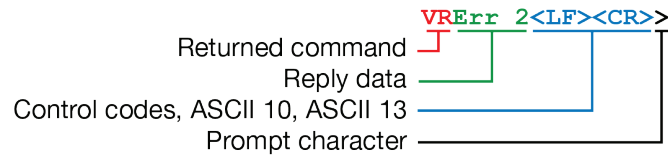

We recommend the host waits for the > prompt before sending the next command; UDP communications are not guaranteed to arrive, so the host software must be able to deal with lost messages.

When an error occurs, the host may request a reply message to be sent to it by using the **GT** command.

Multiple commands can be entered on one line by separating them with a semi-colon (;). The TR-RC120 replies to the commands individually, separating them with <LF><CR> and adding the > prompt after the final command reply.

All commands comprise a code of two letters followed by any parameter necessary. All spaces in the command are ignored.

Numeric parameters are separated by a comma (,). Time periods are specified in milliseconds by default, but you can add 's', 'ms', or 'us' to the parameter to specify seconds, milliseconds, or microseconds. Current is specified in amps by default, but you can add 'A' or 'mA' to the parameter to specify amps or milliamps.

**Note:** All parameters are specified in the 'USA/UK' format, where a half is written as '0.5' and not '0,5'. Examples of acceptable parameters are shown below:

0.1	0.1 milliseconds
200us	200 microseconds
0.1s	0.1 seconds
100mA	100 milliamps
2.45A	2.45 Amps
2.3	2300 milliamps, 2.3 Amps

### 10.3.3 General commands

Any changes you make using Ethernet commands are not saved permanently until you send the **AW** command.

#### Report the RC120 firmware version

This command returns the firmware version running on the TR-RC120. For example, typing:

**VR** returns

```
TR-RC120 (HW101) V001
```

#### Save the settings to memory

**AW**

This command saves the settings to non-volatile memory. If you power cycle the TR-RC120 before sending the **AW** command, all changes are lost and the unit returns to the values set before the last **AW** command.

#### Set the option flags

This command sets the flags for error detection, trigger sense, and SafeSense:

**RE1,m**

Where **m** = flags as follows:

bit 1 =	0	E flag set (error detection enabled)
	1	E flag cleared (error detection disabled)
bit 2 =	0	P flag set (positive triggers)
	1	P flag cleared (negative triggers)
bit 3 =	0	Autosense set (controller waits for light to be connected)
	1	No Autosense (controller assumes light is connected)
bit 6 =	1	Enable current adjust
		Disable current adjust

**Note:** Bit 0 is the least significant bit.

#### Set the internal trigger

These commands control the internal trigger. When set, the output is triggered using an internal trigger signal. Type in:

**TT0** to disable the internal trigger

**TT1** to enable the internal trigger using the period last set

**TT1,p** to enable the internal trigger and set the period.

Where:

**p** = trigger period in milliseconds (10ms to 5s).

**Note 1:** The **TT1** command does not disable external triggers.

**Note 2:** This setting can be saved to non-volatile memory using the **AW** command.

To view the status of the internal trigger, type in:

**ST0**

A typical reply to this command might be:

```
TM1, TP20.00ms
```

Where:

TM = Trigger status. 1 is **on**, 0 is **off**

TP = Trigger period

### Show configuration

This command shows the configuration of the TR-RC120. Type in:

**ST**

A typical reply to this command might be:

```
CH1, MD0, S50.0, 0.0, DL1.000ms, PU1.000ms, RT  
0.0us, IP1, FL0, CS0.000A, RA0.000A
```

Where:

CH	Channel number; this is always 1.
MD	Mode: 0 = continuous, 1 = pulsed, 2 = switched.
S	Percentage brightness: 50.0 = 50%; the second part is always 0.0.
DL	Pulse delay.
PU	Pulse width.
RT	Re-trigger delay.
IP	Always return IP1.
FL	Flags set using the <b>RE1</b> command.
CS	Current rating of the light after being sensed successfully by SafeSense.
RA	Configured voltage or current rating of the light set by the <b>VL</b> command.

---

## Clear configuration

### CL

This command clears the configuration and lighting ratings, and turns the output off. The results of any **VL**, **RU**, **RP**, **RS**, **RW**, **RT**, **RE**, **TT**, and **AW** commands are cleared.

## Simulate an input trigger

### TR1

This command simulates an input trigger. If the TR-RC120 is in pulse mode, it pulses the output once.

## Enable Ethernet messages

This command enables or disables Ethernet messages. Type in:

### GTm

Where:

**m** = 0 to disable Ethernet messages, and

**m** = 1 to enable Ethernet messages.

When Ethernet messages are enabled, any error reports are sent to the most recent UDP or TCP/IP address from which a command has been received. These messages take the form:

### Evtc,e

Where:

**c** = 1 for events concerning the light output, otherwise 0

**e** = the event value (see Section 11.3, "Event codes")

## Clear any errors

Use this command to read the last event or error code when Ethernet messaging has been disabled:

### GR

Any error displayed on the TR-RC120 is cleared. If this was a lighting error, the unit resumes auto-sensing. If there are no outstanding events or errors, the '>' prompt is returned.

## Set/Clear the webpage password

This command sets the web page password. Up to six characters can be chosen. Type in:

### EYasc1,asc2,asc3,asc4,asc5,asc6

Where:

**asc1** to **asc6** are decimal ASCII values for the letters of your password

For example, a value of 65 is 'A', 66 is 'B' and so on up to 90 for 'Z'.

**Note:** When you use this password to access the TR-RC120 through the web page, you must use the actual characters and not the ASCII values. Use upper case characters and do not enter commas or spaces.

### Disable the keypad

You may find it necessary to lock the front panel keypad to prevent any unauthorised changes to the settings to the TR-RC120. To disable the keypad, type in the following command:

**KBd,c**

Where:

- d** = 0 to enable the keypad.
- d** = 1 to disable the keypad, but allow the unlock code to be entered on the keypad.
- d** = 2 to disable the keypad and disallow the unlock code to be entered on the keypad.
- c** = the unlock code, which must be a number from 0 to 255.

You can still access the TR-RC120's settings using Ethernet commands and through its web pages. The settings of this command are restored after a power cycle.

## 10.3.4 Lighting commands

### Set the rating of a light

This command sets the current or voltage rating of the light:

**VL1,v,c**

Where:

- v** = voltage rating (12 to 24).
- c** = current rating (10mA to 2A).

**Note:** If the light is current rated, set the voltage rating to 0; if it is voltage rated, set the current rating to 0.

### Set continuous mode

This command sets the output to continuous mode and allows the brightness to be set:

**RS1,s**

Where:

**s** = brightness as a percentage (0 to 100).

### Set pulse mode

This command sets the output to pulse on a trigger input:

**RT1,p,d,s,r**

Where:

**p** = pulse width in milliseconds (0.1 to 100).

**d** = delay from the trigger pulse in milliseconds (0 to 100).

**s** = brightness setting in percent (0 to 999).

**r** = re-trigger delay in milliseconds ( 0.1 to 999). This parameter is optional and if not set, the minimum allowed re-trigger time is set.

**Note:** An error message is returned if the brightness setting requires a greater current than the maximum current output or if the combination of pulsed width and brightness is not allowed under the limitations of the unit.

### Set switched mode

This command sets the output to switched mode and allows the brightness to be set:

**RW1,s,w,r**

Where:

**s** = brightness setting in percent (0 to 999)

**w** = typical pulse width in ms (optional)

**r** = likely period in ms (optional)

The **w** and **r** parameters are optional and should only be used when the expected pulse width is >100ms and/or the period is >5 seconds. **w / r** gives the expected duty cycle.

### Set automatic sensing of light characteristics

Sets the maximum brightness to be used when automatically sensing the characteristics of the light connected.

**PQ1,0**

**PQ1,m**

**PQ**

Where:

**m** = maximum expected brightness (50% to 999%)

Setting **m** = 0 turns off automatic sensing. The **PQ** command returns the current maximum brightness for automatic sensing.

## 10.4 Command summary

Command	Example	Effect
AW	AW	Save changes.
CL	CL	Clear configuration.
GT	GT1	Enable Ethernet messages.
GR	GR	Clear any error conditions.
EY	EY65,66	Set web page password to 'AB'.
VR	VR	Read the firmware version.
VL	VL1,0,0.5	Set the light to 0.5A.
RS	RS1,65	Set the unit to 65% brightness continuously.
RW	RW1,50	Set the unit to 50% switch mode.
RT	RT1,3,4,50	Set the unit to 3ms pulses, delayed by 4ms, at 50% brightness.
RE	RE1,6	Set the unit to ignore lighting errors and make its trigger input active low.
TT	TT1,100	Set the internal trigger to operate every 100ms.
KB	KB1,23	Disable the keypad buttons on the front panel. Set the unlock code to 23.
TR	TR1	Generate one trigger pulse.
ST	ST	Show the unit's configuration details.

## 11 TR-RC120 reference information

This section of the user manual contains information about the TR-RC120's specification, ratings. You can find further information in Section 11.2, "Restrictions", Section 11.3, "Event codes", and Section 11.4, "Error codes".

### 11.1 Specifications and ratings

RC120	
User interface	Ethernet and Pushbutton
Output channel	One constant current output with SafeSense
Output current	Up to 1.2A continuous and 2.0A pulsed
Output voltage	0V to 32V
Pulsed output average power	25W maximum
Trigger input	Smart input compatible with 3V-24V, TTL, NPN, and PNP. Input impedance 8kΩ nominal.
Pulse timing	From 100μs to 100ms in steps of 100μs.
Delay from trigger to pulse	Maximum 10μs fixed latency plus user adjustable steps of 100μs to a maximum of 100ms.
Timing repeatability	±5μs (delay + pulse up to 60ms), otherwise ±50μs
Switch mode latency	100μs maximum
Trigger rate	100Hz maximum
Supply voltage	24V DC ±10% regulated An SELV power supply is required
Dimensions	120mm long x 35mm wide x 101mm high (excluding DIN fixing)
Weight	0.3kg
Mounting	DIN rail mount
Operating temperature	5°C to 50°C
Humidity	95% maximum (non-condensing)

## 11.2 Restrictions

The following timings and restrictions are applied when commands are entered. Exceeding these values causes an error to be returned.

The keypad interface prevents invalid values being entered at the controller.

### 11.2.1 Continuous mode

The maximum continuous output current of the TR-RC120 is 1.2A.

### 11.2.2 Switched mode

The maximum delay from the trigger input changing state to the output current switching on or off is 100 $\mu$ s.

The maximum output current of the TR-RC120 is 1.2A.

### 11.2.3 Pulse mode

The maximum pulsed output current of the TR-RC120 is 12A.

When you set a delay of 0 $\mu$ s, there is a delay of approximately 4 $\mu$ s. For pulse widths of 100 $\mu$ s the output voltage and current cannot be measured.

The following pulse width and duty cycle restrictions apply:

Pulse output current	Restriction
$\leq 1A$	100ms max pulse width
$> 1A$	10ms max pulse width
$> 1.5A$	50% max duty cycle

## 11.3 Event codes

On receipt of a **GT1** command, the TR-RC120 sends event messages over its Ethernet link when a light is connected or an error occurs. The message format is:

**Evt1**,<event code>

Some event codes are displayed on the TR-RC120's front panel; these are shown in red.

Event number	Reason
1 to 127	An error has occurred. See Section 11.3, "Event codes".
128	A light has been connected and is working.

Event number	Reason
129	A light has been connected but does not have a current or voltage rating.
130 <b>FAT</b>	A over temperature error has occurred.
131 <b>FAC</b>	An over current error has occurred.
132	An error has occurred while autosensing the rating of the light.
138	SafePower train-up has completed.
139	SafePower train-up has failed or been cancelled.
140	In switch mode, the light has been turned off because the duty cycle is too high.

## 11.4 Error codes

Some error codes are displayed in the TR-RC120's front panel; these are shown in red.

Error number	Reason
Err 1	A parameter value is invalid.
Err 2	Command not recognised.
Err 3	A numeric value is in the wrong format.
Err 5	This is a warning, not an error. One of the parameters is out of range and the value of that parameter has been adjusted. For example, sending an <b>RT</b> command with a delay of 0 $\mu$ s returns an 'Err 5'. The command is accepted, but the delay is set to the minimum allowed.
Err 8, 12	EEPROM corrupt. The configuration has been cleared.
Err 9, 20	Settings could not be saved to EEPROM.
Err 19	A light has been connected but no rating has been set.
Err 21, 23	A sensing error has occurred (see Section 7.8, "Fault detection").
Err 22, <b>FAA</b>	The light is not compatible with the controller. The TR-RC120 does not drive the light and the web page reports <b>Triniti Chip device protection</b> .

Error number	Reason
Err 27	Ethernet settings cannot be read from the EEPROM. They may be incorrect.
Err 34, 47, <b>PO</b>	The internal power dissipation is too high. Output turned off.
Err 35, <b>OP</b>	The output current to the light is too low.
Err 36, <b>SH</b>	The output is short circuit.
Err 37, <b>HI</b>	The voltage required for the lighting has increased too much. Check for ageing of the light or a failed LED.
Err 38, <b>LO</b>	The voltage required for the lighting has decreased too much. Check for ageing of the light or a failed LED.
Err 39	The internal protection has prevented the SafePower voltage going too high.
Err 40, 41, 45, <b>FAC</b>	<b>Fatal error:</b> The unit is outputting more current than expected.
Err 42, <b>SH</b>	The output current is too high.
Err 43, <b>OP</b>	The requested output current requires too high a voltage.
Err 44, <b>FAt</b>	<b>Fatal error:</b> The TR-RC120 is too hot. The unit has a thermal cut out which operates between approximately 65°C and 70°C depending on conditions.
Err 46	The channel output power is greater than the maximum allowed 30W.
Err 47, <b>FAS</b>	Internal protection has activated to prevent too much heat in the output driver.

Issue 009 - September 2021

© Copyright 2021 Gardasoft Vision Ltd

Gardasoft Vision Ltd  
Trinity Court  
Buckingway Business Park  
Cambridge CB24 4UQ UK  
tel: +44 1954 234970