

This lens is designed for 12k / 5 μ m line scan sensors but also can be used in many applications with area sensors up to 67mm diagonal. Optimized for a specific magnification of 1.0x the lens provides high performance in a small and compact package. The universal V48-Mount enables the best azimuth adjustment and the assembly of accessories like focusing mount, extension tubes and camera adapters.

Key features	Applications
<ul style="list-style-type: none"> • Designed for 12k / 5 μm line scan sensors • Best azimuth marking • 400 nm to 1000 nm broadband AR-coating • Lockable aperture setting 	<ul style="list-style-type: none"> • FPD inspection • PCB inspection • High resolution defect detection • AOI (Automated Optical Inspection)

Technical specifications	
Type [standard]	V48
ID [standard]	1078948
Interface	V48-Mount
Focal length [mm]	89
F/# range	F/2.8 ... F/11
Numerical aperture [object image]	0.09 0.09
Max. sensor size [mm]	62.5
Max. angle of view [°]	20
Rec. magnification range	-1.0 (-1.1 ... -0.9)
Rec. working distance range [mm]	125 ... 143
Max. mechanical focus travel [mm]	-
Filter thread [mm]	M46 x 0.75
Storage temperature [°C]	-25 ... +70
Net. weight [standard] [g]	250
Additional info	-
f'eff [mm]	88.82
SF [mm]	-51.86
S'F' [mm]	51.86
HH' [mm]	-20.31
β 'P	1.00
SEP [mm]	36.97
S'AP [mm]	-36.97
Σ d [mm]	53.62

MTF charts

Spectrum name	VIS					
Wavelengths [nm]	425	475	525	575	625	675
Rel. weights [%]	8	16	23	22	19	13

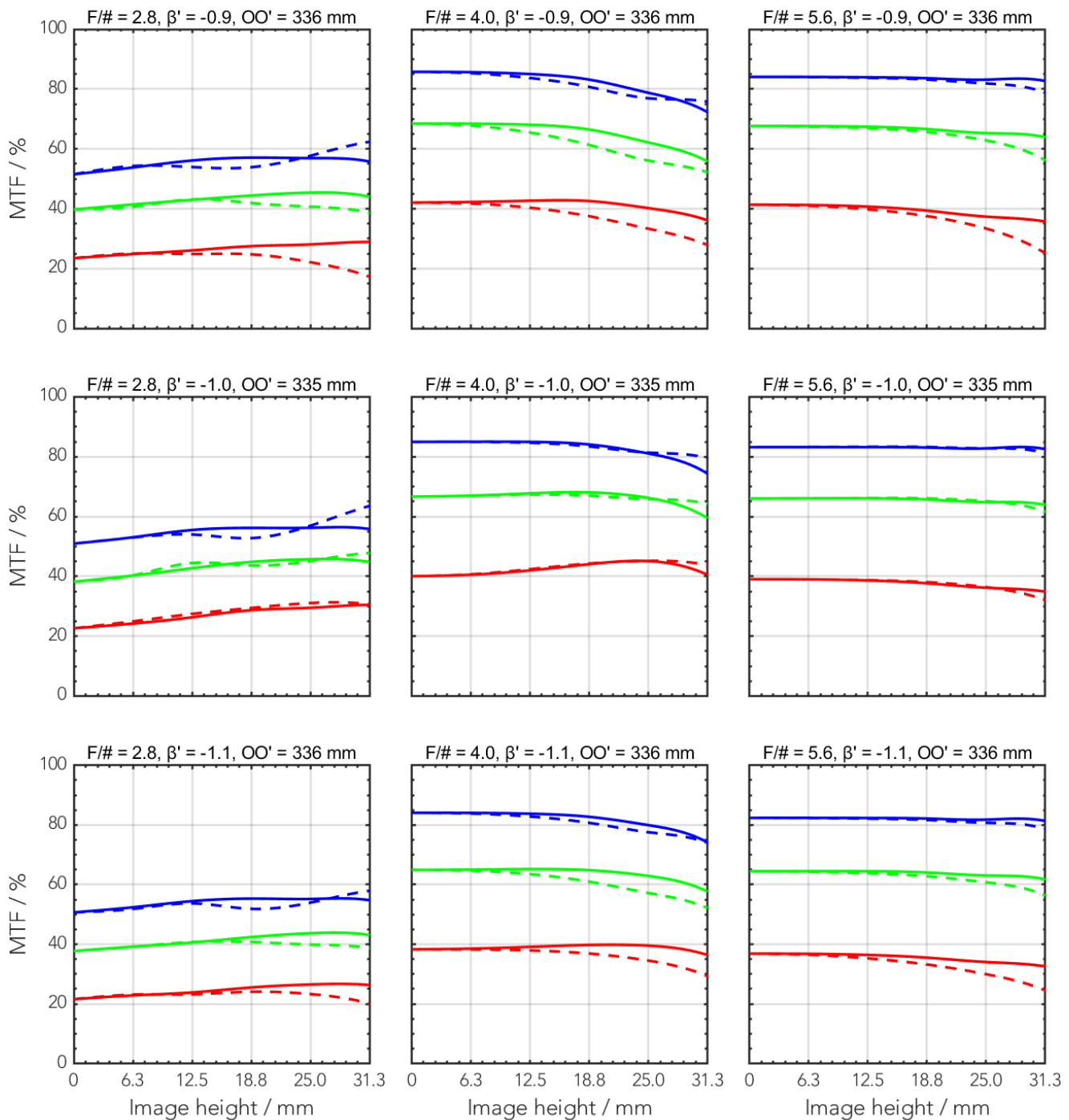

Rel. illumination vs. image height

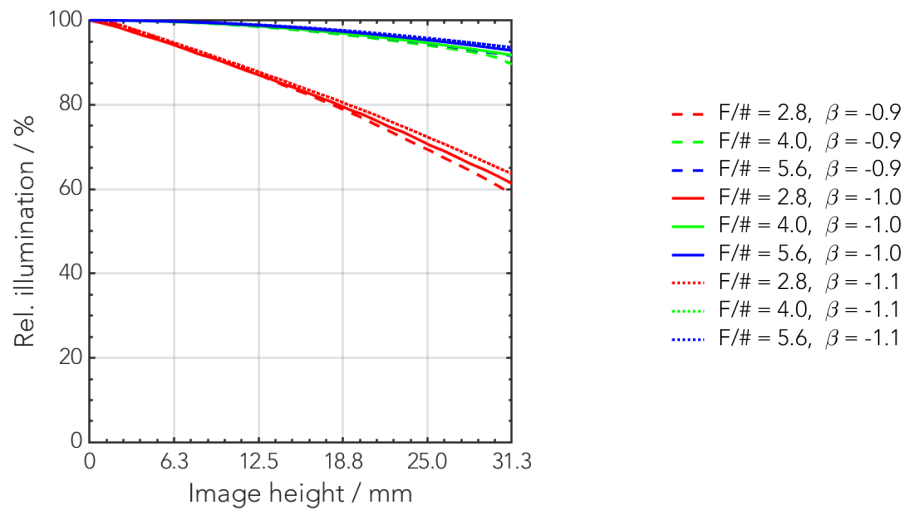

Distortion vs. image height

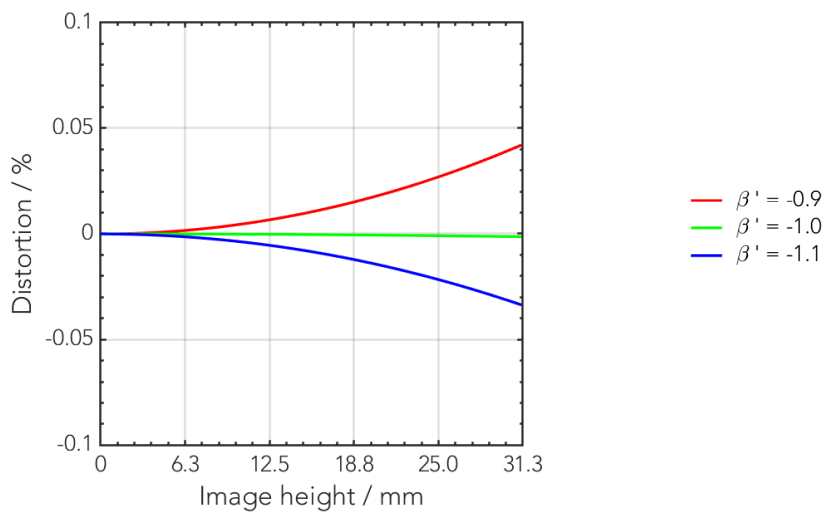

Transmittance vs. wavelength

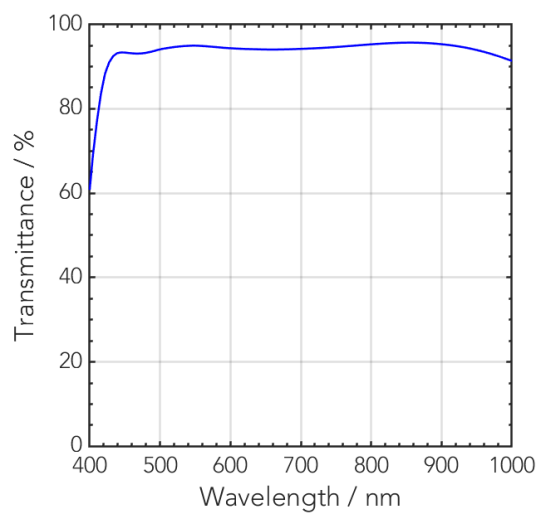

Technical drawings

* WD and s'A
in air at
beta' -1.0

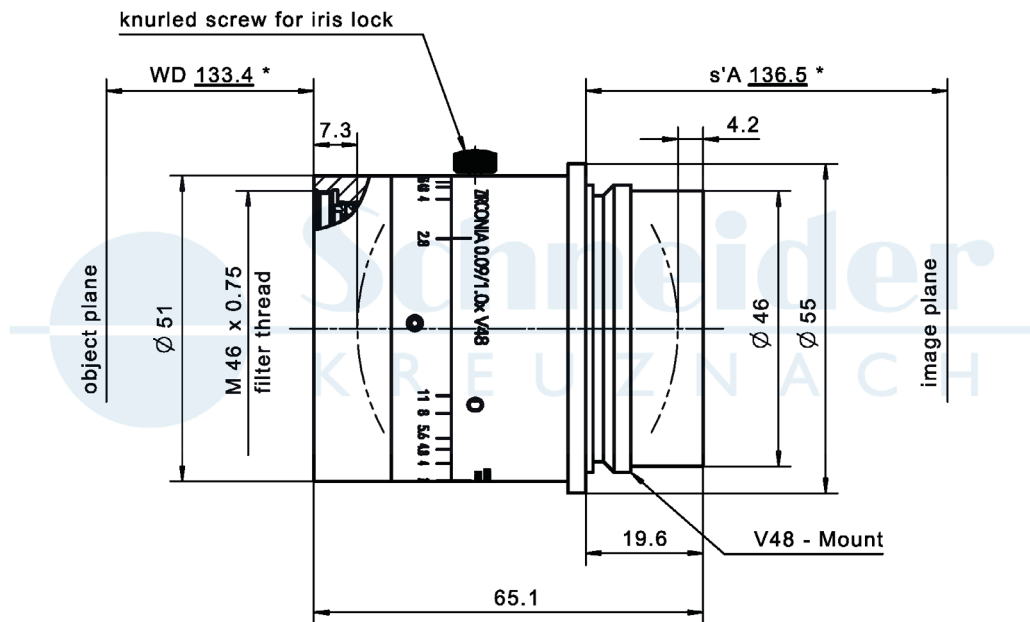

Accessories	Mount	Eff. length	ID
Unifoc 22	V48 / V70	15.6 – 37.6 mm	1075304
Adapter	V48 / M42 x 0.75	8.5 mm	1072652
	V48 / M42 x 1	8.5 mm	1072660
	V48 / M58 x 0.75	10 mm	1072659
	M58 x 0.75 / M90 x 1	4 mm	1084880
	V70 / M72 x 0.75	10 mm	1072419
	M72 x 0.75 / M42 x 1	6 mm	1079515
	M72 x 0.75 / M58 x 0.75	6 mm	1075556
	M72 x 0.75 / M90 x 1	4 mm	1084879
	M72 x 0.75 / M95 x 1	4 mm	1077013
	Extension Tube	V48	10 mm
V48		25 mm	1072651
V48		50 mm	1072662
M72 x 0,75		5 mm	1072420
M72 x 0,75		10 mm	1072421
M72 x 0,75		25 mm	26406
M72 x 0,75		50 mm	1054733
M72 x 0.75		100 mm	1079483
M90 x 1		10 mm	1084875
M90 x 1		25 mm	1084876
M90 x 1		50 mm	1084877
M90 x 1		100 mm	1084878
M95 x 1		10 mm	1077290
M95 x 1		25 mm	1062892
M95 x 1		50 mm	1062893
M95 x 1	100 mm	1062894	

Annotation	
Focal length	Nominal focal length
F/# range	Image space F-number range for infinity focus position
Numerical aperture	Maximum real numerical aperture (depending on recommended magnification range either for infinity or respective fixed magnification)
Max. sensor size	Image circle diameter
Max. angle of view	Angle of view associated with maximum sensor size (depending on recommended magnification range either for infinity or respective fixed magnification)
Rec. magnification range	Magnification range as recommended by Schneider-Kreuznach
Rec. working distance range	Working distance, i.e. distance between object and first mechanical element, associated with recommended magnification range
Max. mechanical focus travel	Maximum possible movement of the lens from infinity position (depending on recommended magnification range either for infinity or respective fixed magnification)
Net weight	weight of unpacked lens without lens cap
f'_{eff}	Effective focal length
SF	Distance between vertex of first lens surface and object space focal point
S'F'	Distance between vertex of last lens surface and image space focal point (back focal distance at infinity)
HH'	Distance between principal planes
$\beta'P$	Pupil magnification (= exit pupil diameter / entrance pupil diameter)
SEP	Distance between vertex of first lens surface and entrance pupil
S'AP	Distance between vertex of last lens surface and exit pupil
Σd	Distance between vertices of first and last lens surface
s'A	Flange focal distance (in air) for infinite object distance (depending on recommended magnification range either for infinity or respective fixed magnification)
β'	Magnification (= image size / object size), negative value because image is inverted
OO'	Distance between object and image

Unless otherwise stated all dimensions in this data sheet are in mm.