

This compact 2/3" C-Mount SWIR lens is designed for the 800 - 1800 nm spectral range. With its robust mechanical design and locking screws for focus and iris it maintains its high optical imaging performance even in harsh environment. A special SWIR coating and internal lacquering reduces stray light, resulting in a high contrast images.

Key features	Applications
<ul style="list-style-type: none"> • Optimized for 800 - 1800 nm • For sensor sizes up to 2/3" • Compact and robust mechanics • Locking screws for iris and focus 	<ul style="list-style-type: none"> • Solar cell inspection • Food sorting • Agriculture observation • Geology analysis

Technical specifications	
Type [standard]	C
ID [standard]	1063163
Interface	C-Mount
Focal length [mm]	23
F/# range	F/1.4 ... F/11
Numerical aperture [object image]	- 0.33
Max. sensor size [mm]	11
Max. angle of view [°]	27
Rec. magnification range	-0.2 ... 0
Rec. working distance range [mm]	98 ... ∞
Min. working distance without extension tubes [mm]	63
Filter thread [mm]	M30.5 x 0.5
Storage temperature [°C]	-25 ... +70
Net. weight [standard] [g]	115
Additional info	-
f ^{eff} [mm]	23.13
SF [mm]	8.93
S'F' [mm]	15.76
HH' [mm]	-7.17
β'P	2.34
SEP [mm]	18.82
S'AP [mm]	-38.29
Σd [mm]	32.25

MTF charts

Spectrum name	SWIR					
Wavelengths [nm]	920	1070	1220	1370	1520	1670
Rel. weights [%]	16.9	18.2	17.7	17.1	15.9	14.2

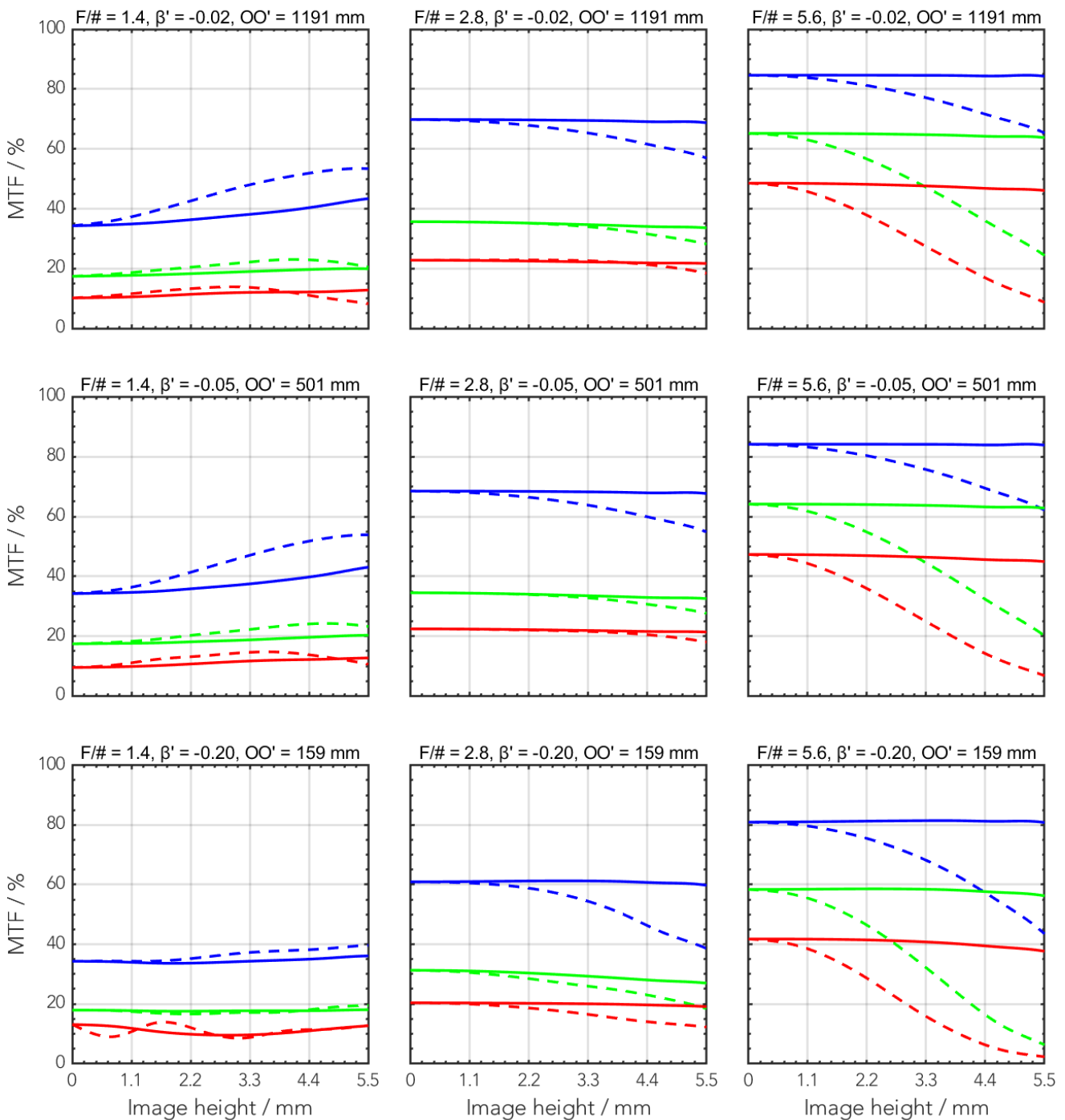

Rel. illumination vs. image height

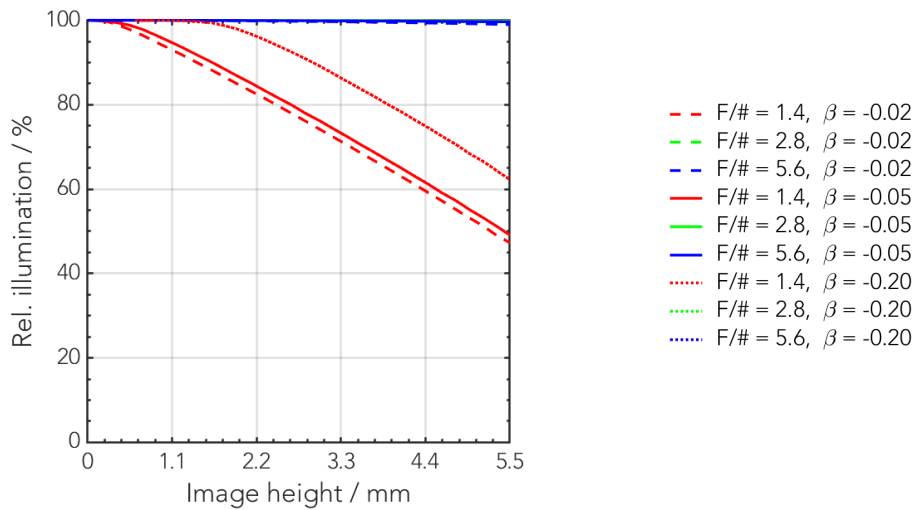

Distortion vs. image height

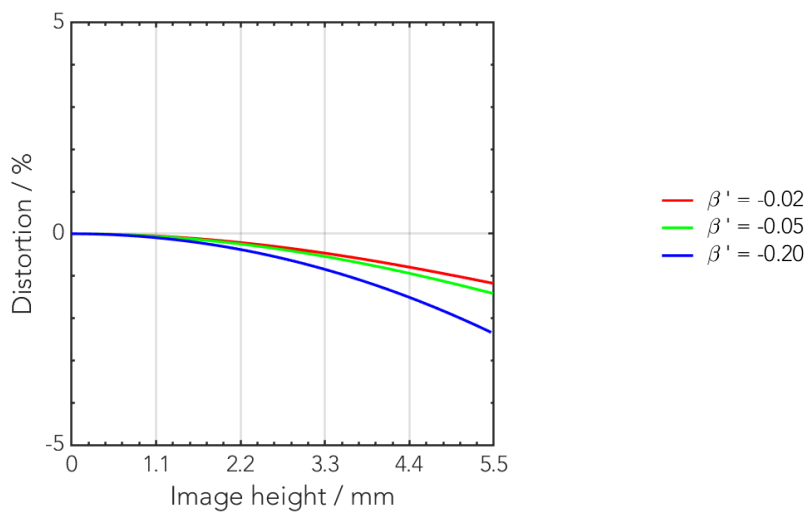

Transmittance vs. wavelength

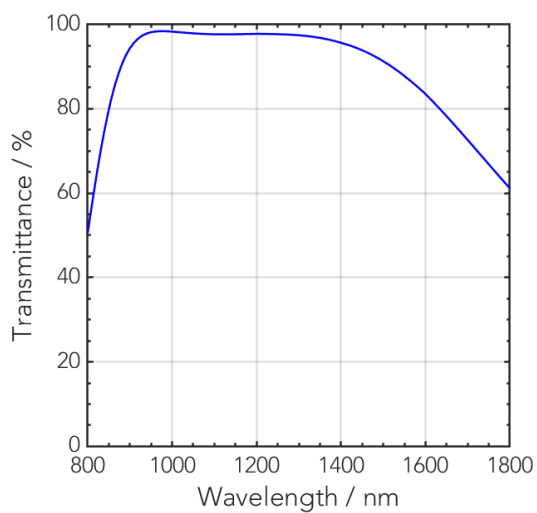

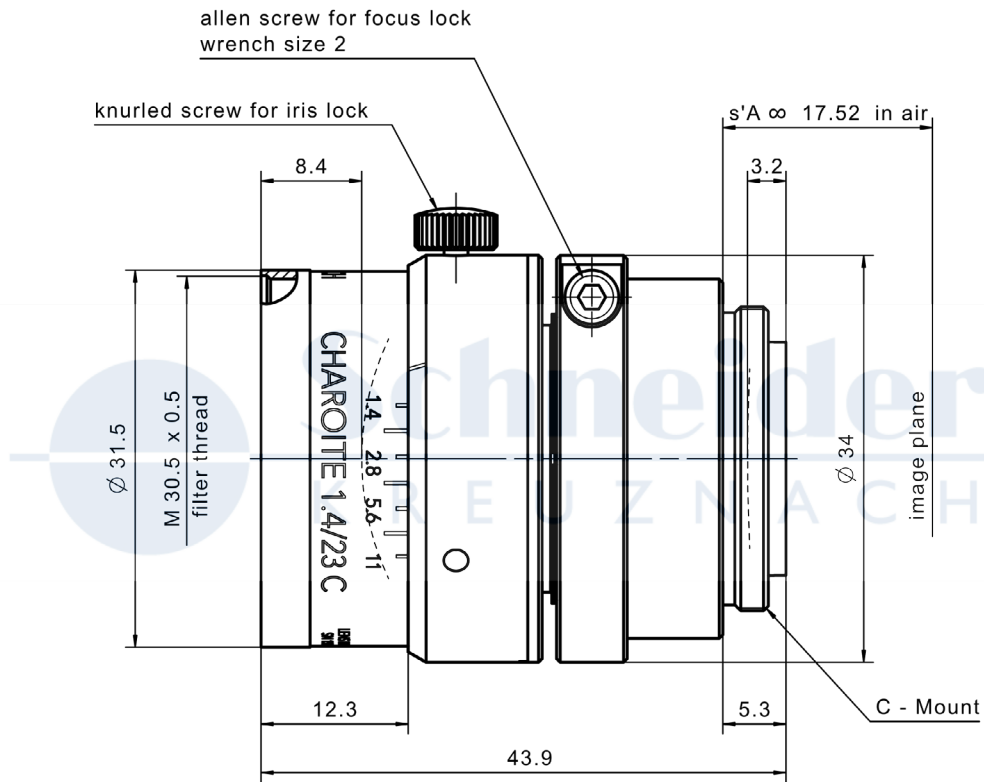

Accessories	Mount	Eff. length	ID
Adapter	CS-Mount	5 mm	25081
	C-Mount / M42 x 1	5.5 mm	1075817
Extension tube	C-Mount / C-Mount	5 mm	39316
	C-Mount / C-Mount	8 mm	39315
	C-Mount / C-Mount	10 mm	39312

Annotation	
Focal length	Nominal focal length
F/# range	Image space F-number range for infinity focus position
Numerical aperture	Maximum real numerical aperture (depending on recommended magnification range either for infinity or respective fixed magnification)
Max. sensor size	Image circle diameter
Max. angle of view	Angle of view associated with maximum sensor size (depending on recommended magnification range either for infinity or respective fixed magnification)
Rec. magnification range	Magnification range as recommended by Schneider-Kreuznach
Rec. working distance range	Working distance, i.e. distance between object and first mechanical element, associated with recommended magnification range
Max. mechanical focus travel	Maximum possible movement of the lens from infinity position (depending on recommended magnification range either for infinity or respective fixed magnification)
Net weight	weight of unpacked lens without lens cap
f'_{eff}	Effective focal length
SF	Distance between vertex of first lens surface and object space focal point
S'F'	Distance between vertex of last lens surface and image space focal point (back focal distance at infinity)
HH'	Distance between principal planes
$\beta'P$	Pupil magnification (= exit pupil diameter / entrance pupil diameter)
SEP	Distance between vertex of first lens surface and entrance pupil
S'AP	Distance between vertex of last lens surface and exit pupil
Σd	Distance between vertices of first and last lens surface
s'A	Flange focal distance (in air) for infinite object distance (depending on recommended magnification range either for infinity or respective fixed magnification)
β'	Magnification (= image size / object size), negative value because image is inverted
OO'	Distance between object and image

Unless otherwise stated all dimensions in this data sheet are in mm.