

VNP-604MX-M/C 6 H

604 Megapixel Pixel Shifting Camera
Equipped with Thermoelectric Peltier



The VNP-604MX-6 H, a pixel shifting camera equipped with thermo-electric Peltier (TEC) cooled, is designed not only for applications where extremely high resolution is required but also where high quality image is essential. The TEC maintains the operating temperature of the image sensor at up to $15 \pm 2^\circ\text{C}$ below ambient temperature to reduce noise significantly. Pixel shifting technology based on a precise piezoelectric stage allows image captures as high as 604 million pixels at 1.5 fps. The CoaXPress interface adopted by this camera supports transmitting image data at up to 25 Gbps using four coaxial cables. This new camera delivers unique and unparalleled performance in the most demanding applications such as FPD, PCB and semiconductor inspections.

VIEWWORKS

VNP-604MX-M/C 6 H

604 Megapixel Pixel Shifting Camera Equipped with Thermoelectric Peltier

Main Features

- Nano Stage Pixel Shifting Mechanism
- Thermoelectric Peltier Cooled – $15 \pm 2^\circ\text{C}$ below
- Extended Resolutions up to 1,359 MP
- CoaXPress Interface
- Electronic Rolling Shutter
- DSNU and PRNU Correction
- Flat Field Correction with Sequencer Control
- Hot Pixel Correction
- Dynamic Defective Pixel Correction

Applications

- Flat Panel Display Inspection
- Electronics Inspection
- Semiconductor Inspection
- Document / Film Scanning

Specifications

	Model	VNP-604MX-M/C 6 H
Resolution (H×V)	1× (1 Shot)	14192 × 10640
	4× (4 Shot)	28384 × 21280
	Sensor	SONY IMX411
	Sensor Size (Diagonal)	53.36 mm × 40.01 mm (66.7 mm)
	Pixel Size	3.76 μm × 3.76 μm
	Interface	CoaXPress
Max. Frame Rate	1× Mode	6.2 fps (with Overlapped Acquisition)
	4× Mode	1.5 fps (with Overlapped Acquisition)
	Exposure Time (1 μs step)	1 μs – 60 s
	Partial Scan (Max. Speed)	546.4 fps at 2 Lines (12 bit)
Pixel Data Format	Mono	Mono 8 / Mono 10 / Mono 12
	Color	RG Bayer 8 / RG Bayer 10 / RG Bayer 12
	Electronic Shutter	Rolling Shutter
Trigger Synchronization	Overlapped Acquisition	Free-Run
	Non-overlapped Acquisition	Hardware Trigger, Software Trigger or CXP
	Dynamic Range	78 dB
	Gain Control	1× ~ 32×
	Black Level Control	0 ~ 255 LSB at 12 bit
	Shift Range	0 ~ 15 μm , 1 nm step
	Shift Resolution	0.001 μm
	Shift Control	Manual Mode or Sequence Mode (4/9 Shot Mono, 4/16/36 Shot Color)
	Shift Latency	< 5 ms
	Cooling Method	Thermoelectric Peltier Cooling
	Cooling Performance	$15 \pm 2^\circ\text{C}$ below ambient temperature – Standard cooling with a fan
	Dimension / Weight	110 mm × 110 mm × 134 mm, 2.5 kg (with M-72 mount)
	Temperature	Operating: 0°C ~ 40°C , Storage: -40°C ~ 70°C
	Lens Mount	M72-mount, Custom mount available upon request
Power	External	11 ~ 24 V DC
	Dissipation	Typ. 31.0 W
	Compliance	CE, FCC, KC
	API SDK	Vieworks Imaging Solution 7.X

VNP-604MX-M/C 6 H

604 Megapixel Pixel Shifting Camera Equipped with Thermoelectric Peltier

Spectral Response

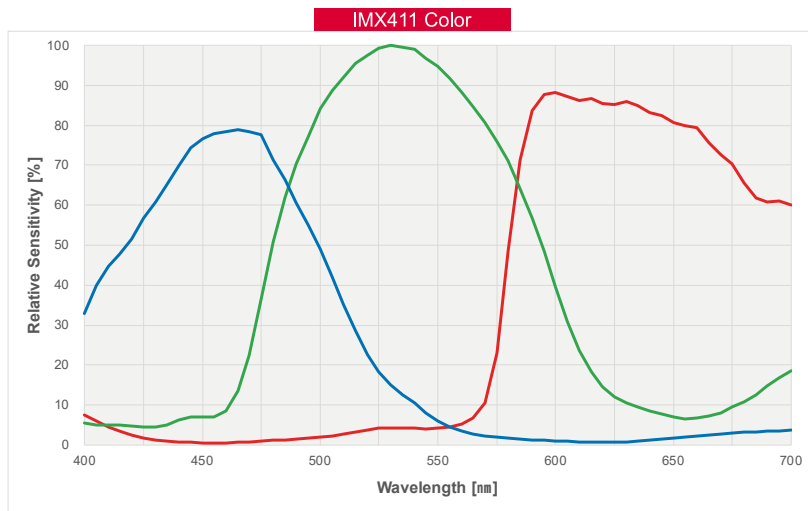
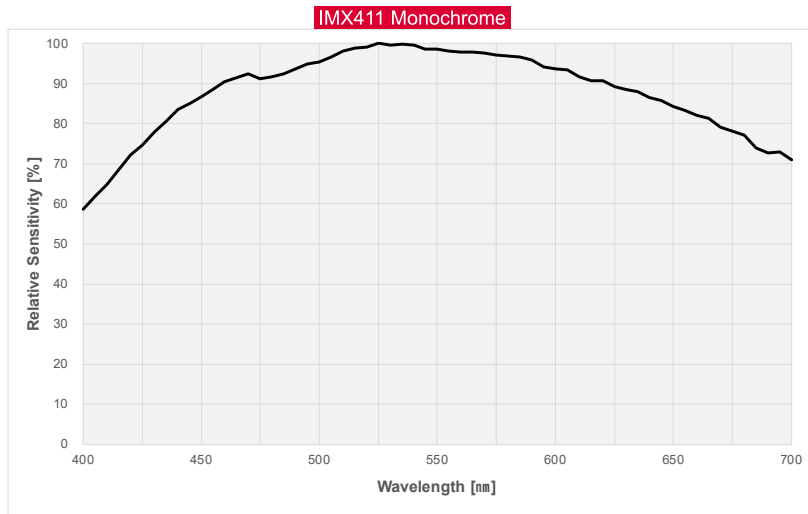

Ordering Scheme

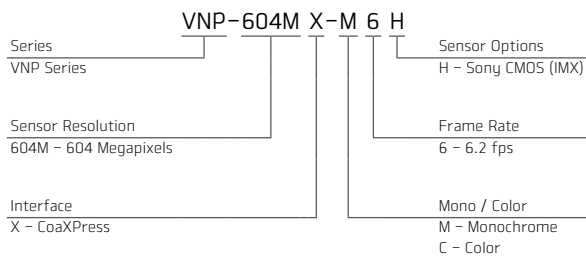

Connector Specification

Power



1, 2, 3: +12 V DC
4, 5, 6: GND
(HR10A-7R-6PB)

Control



1: Trigger IN+
2: Trigger IN-
3: Strobe Out-(GND)
4: Strobe Out+
(HR10A-7R-4S)

Data Transfer / Communications

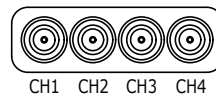

CH1 CH2 CH3 CH4

CH1: Master Connection
75 Ω, DIN 1.0/2.3

Connectors on camera body

VNP-604MX-M/C 6 H

604 Megapixel Pixel Shifting Camera Equipped with Thermoelectric Peltier

Mechanical Dimensions

Unit: mm

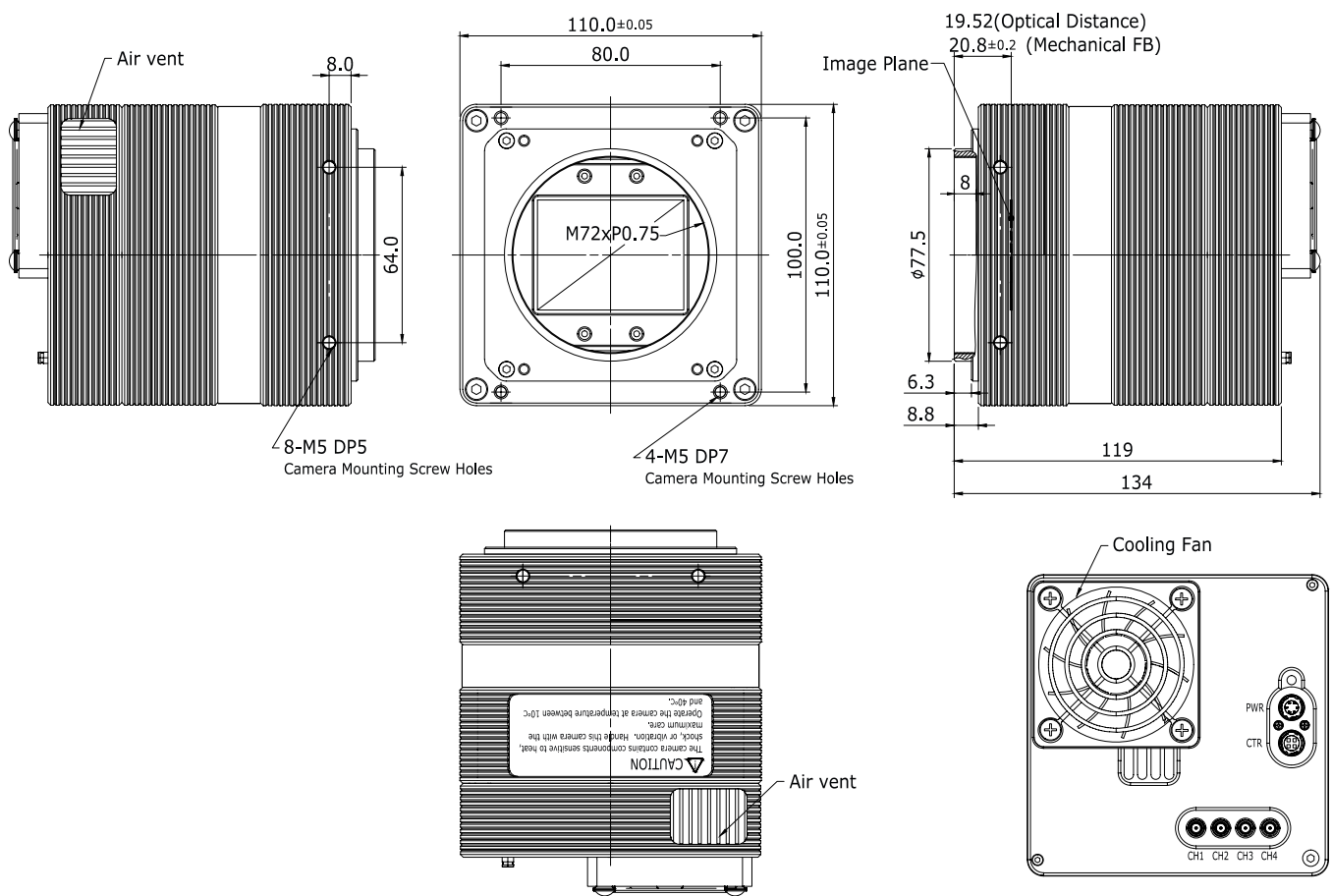

CAM-VIEW35-08/2020 · Subject to technical change without notice. No liability is accepted for errors which may be contained in this document.

VIEWWORKS