

# GV 4000

Vision System

## Installation Manual



## Notice

GV 4000 Installation Manual  
Document Number 405-00068-00

Copyright 2017 Teledyne DALSA Incorporated.  
All rights reserved.

All copyrights in this manual, and the hardware and software described in it, are the exclusive property of Teledyne DALSA Incorporated and its licensors. Claim of copyright does not imply waiver of Teledyne DALSA Incorporated or its licensors other rights in the work. See the following Notice of Proprietary Rights.

### NOTICE OF PROPRIETARY RIGHTS

This manual and the related hardware and software are confidential trade secrets and the property of Teledyne DALSA Incorporated and its licensors. Use, examination, reproduction, copying, transfer and/or disclosure to others of all or any part of this manual and the related documentation are prohibited except with the express written consent of Teledyne DALSA Incorporated.

The information in this document is subject to change without notice. Teledyne DALSA Incorporated makes no representations or warranties with respect to the contents of this manual and specifically disclaims any implied warranties of merchantability or fitness for a particular purpose. Teledyne DALSA Incorporated assumes no responsibility for errors or omissions in this document.

iNspect, Sherlock, and the Teledyne DALSA logo are trademarks of Teledyne DALSA Incorporated. All other trademarks are the property of their respective owners.

Teledyne DALSA Industrial Products  
**Information:** [info.ipd@teledyne.com](mailto:info.ipd@teledyne.com)  
**Support:** [support.ipd@teledyne.com](mailto:support.ipd@teledyne.com)  
**Web:** <http://www.teledynedalsa.com/visionsystems>

700 Technology Park Drive  
Billerica, MA, USA 01821  
**Tel** 1.978.670.2002 **Fax** 1.978.670.2010



Declaration of Conformity	
Manufacturer	Teledyne DALSA Industrial Products Inc. 700 Technology Park Drive Billerica MA 01821 USA
CE	We declare that this product has been tested to comply with the EC Directive for a class A digital device in accordance with EN55022/CISPR22
FCC	We declare that this product has been tested and found to comply with the limits for a class A digital device, pursuant to Part 15 of the FCC rules. These limits are designed to provide reasonable protection against harmful interference in a residential installation.  This equipment generates, uses and can radiate radio frequency energy and may cause harmful interference to radio communication.
Other	
CFR 21 Part 11	This product provides tools needed for users to implement an auditing program that could be in compliance with CFR 21 Part 11. These tools include: <ul style="list-style-type: none"> <li>• System or software backup and restore</li> <li>• System software security (password login and access limits)</li> <li>• Protection of system backup files from modification.</li> <li>• Record of actions by users with time stamp information</li> <li>• Time stamp information on data output.</li> </ul>

## Handling Precautions

Care should always be exercised when handling and operating your GV 4000 System. Even though the system is encased within a rugged, industrial enclosure, incorrect use or handling can result in damage to your investment. To prevent this, we recommend the following precautions:

- Avoid “hot-plugging” cables and devices. Be sure to shut the system down and remove power before connecting or disconnecting anything to it.
- Do not use in a Free-standing operation. Mount the system properly to prevent it from falling accidentally. Mounting hardware is provided with the system.
- Always use the GEVA system within it’s recommended operating conditions. Refer to the complete specifications on page [23](#).
- Do not install the GEVA system in a location that will expose it to excessive heat, humidity, vibration, impact, corrosive substances, flammable substances, static electricity or Electro Static Discharge (ESD).
- Never expose the internal electronics by opening the enclosure.
- Do not attempt to service or modify the GEVA system by opening the enclosure. This system has no field-replaceable components. Tampering with the system will void the product warranty.

## Warranty

Teledyne DALSA warrants the GV 4000 Vision System against defects in materials and workmanship for a period of twelve (12) months from the date of delivery. Teledyne DALSA and its representatives expressly disclaim any and all other warranties.

Your sole remedy shall be repair or replacement of the GV 4000 Vision System product and associated optional components, provided that the defective product is returned within the warranty period.

If you need to return the GV 4000 Vision System, you must contact the Teledyne DALSA representative who sold you the product. Do not return your product to Teledyne DALSA without prior authorization.

Teledyne DALSA assumes no liability for damages resulting from the use of this manual.



<b>Introduction</b>	GV 4000 Vision System .....	6
	Product Support .....	6
	Components .....	7
<b>Installation</b>	Connecting the GV 4000 .....	8
	Front Connections .....	8
	Rear Connections .....	9
	GigE Cameras .....	10
	Typical Configuration using the PL-USB .....	11
	Typical Configuration using the DCI-101 .....	12
<b>Software</b>	Getting Started .....	13
	Directory Structure .....	13
	The License Manager .....	14
	iNspect Express Setup .....	15
	iNspect Express Configurator .....	16
	iDiscover .....	17
	Sherlock Setup .....	18
	Sapera CamExpert .....	19
	Sapera Acquisition Wizard .....	20
	Changing Camera Order .....	21
	Unified Write Filter .....	22
	Acronis True Image Software .....	22
<b>Specifications</b>	GV 4000 Specifications .....	23
	Mechanical Drawings .....	24
<b>I/O Modules</b>	PL-USB Overview .....	25
	DCI-101 Overview .....	26



## GV 4000 Vision System Overview

The GV 4000 is a compact vision system that supports image acquisition, processing, display and communications. The system is equipped with 4 Ethernet ports for interfacing GigE style cameras and 2 Ethernet ports for complementary network devices. The GV 4000 uses industrial grade components encased within a fanless aluminum enclosure. It is offered with panel mountable hardware.

## Product Support

This manual will assist you with the installation and setup of your GV 4000 product and the embedded inspection software. It describes what the product supports and how to connect the external interfaces. If your questions are not answered in this reference, please contact your local Teledyne DALSA representative.

In addition to this installation manual, the following information ships with the product:

1. Online help: Fingertip help is available on every screen (panel) of the iNspect Express or Sherlock User Interface.
2. The software User Manual is included on the CD that ships with the product.
3. Self help material is also included on the CD.
4. Factory support is available at [support.ipd@teledyne.com](mailto:support.ipd@teledyne.com)
5. Call, fax or email your local representative who sold you the product.

## GV 4000 Vision System Components

GV 4000 vision systems are shipped with the components listed below. Take a few moments to verify that everything has arrived in good condition. If your product has been visibly damaged during shipment or is missing parts, please contact your Teledyne DALSA representative immediately.

Standard components (ship with every GV 4000 Vision System):

Component	Description
<u>GV 4000 Vision System</u> GV4000-03 or GV4000-04	Fully integrated vision system with iInspect Express (-03) or Sherlock (-04) embedded software, power connector, and panel mounting hardware.
iInspect Express or Sherlock CD	CD including PC emulation software and associated product manuals and drawings.

Optional components (sold separately):

Component	Description
A-CAM-GX-XXXX-XX	Genie Series GigE cameras .
A-CAB-GE-X	GigE CAT5e camera cables (video data, network communication).
A-PL-USB	USB breakout module for camera interfacing and additional I/O.
A-DCI-101	Breakout module for camera interfacing.
A-CAB-G3-IO-X	Genie Nano IO/Power/Trigger cable (for free wire, PL-USB or DCI-101).
A-CAB-G2-TPS-X	Genie TS IO/Power/Trigger cable (for free wire, PL-USB or DCI-101).
A-CAB-GEVA-FX	Genie Classic IO/Power/Trigger cable (for free wire, PL-USB or DCI-101).
A-CAB-GTP-X	Genie classic Trigger/Power cable (for free wire connection).

**Note:** The PL-USB uses camera Input2 as the trigger and Output2 as the strobe.



## Connecting the GV 4000 Vision System

This section details the physical connections on the GV 4000 vision system. The GV 4000 provides connectors on both the front and rear plates.

### Rear Connections

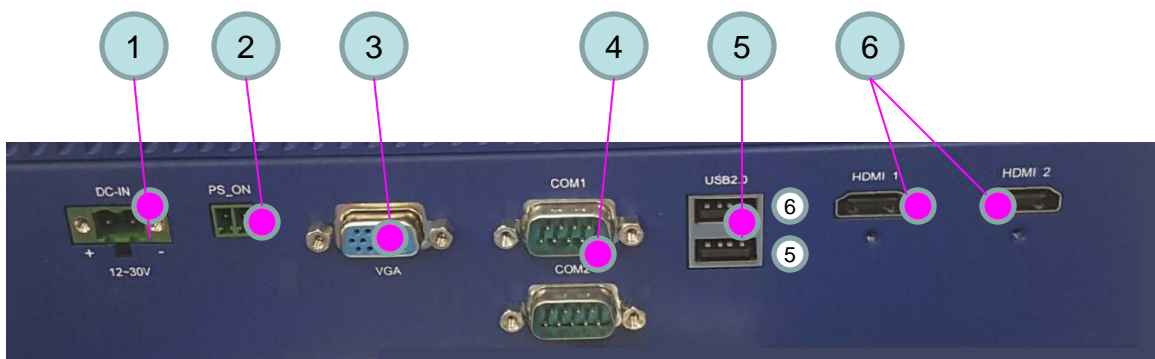

1. Power connection. Supports 12-30VDC @
2. Optional external power supply switch
3. VGA video output up to 2048x1536 resolution
4. Two Serial ports, configured as COM1 and COM2 at 11520,8,0,1,0
5. Two USB 2.0 port. Typically used to connect PL-USB I/O module, Keyboard, Mouse or flash drive.
6. Two HDMI video outputs up to 2560x1600 resolution @ 60 Hz, (larger resolution at lower refresh rates).

## Front Connections

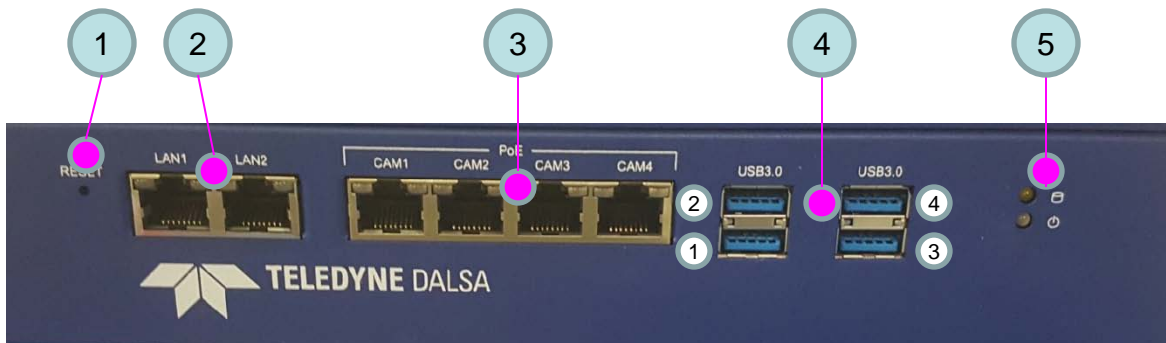

1. Reset button – recessed behind the front plate. Use blunt pointed object and hold for 5 seconds to reset the unit.
2. Two Gigabit Ethernet ports for Network or peripheral devices. These do not support POE.
3. Four Gigabit Ethernet ports for cameras, supporting Power Over Ethernet (POE). Default IP settings are listed below.
4. Four USB 3.0 Ports
5. LEDs: HDD and Power.

Label	Address	Connection
LAN1	Dynamic Address, DHCP enabled	Network or PLC
LAN2	Dynamic Address DHCP enabled	Network or PLC
CAM1	Static IP Address 192.168.11.1	Camera Port 1
CAM2	Static IP Address 192.168.12.1	Camera Port 2
CAM3	Static IP Address 192.168.13.1	Camera Port 3
CAM4	Static IP Address 192.168.14.1	Camera Port 4

**Note:** Camera Ethernet cables must be type Cat5e. Use A-CAB-GE-X.

LAN left LED: Off = 10 Mbits/s; GREEN = 100 Mbits/s; ORANGE = 1000 Mbits/s

LAN right LED: ON = port active; BLINK = port traffic

## GigE Cameras

The GV 4000 supports Teledyne DALSA Genie series cameras for image acquisition. These include the Genie Nano, Genie TS and Genie classic.

The Genie family, including the TS series, offers a range of sensor resolution from 640x480 up to 5120x5120 pixels. The following should be noted when matching your application camera needs to the GV 4000:

1. Sherlock has no limit on the number of cameras supported.
2. iNspec Express “Standard” license supports up to 4 cameras.
3. iNspec Express “Extended” license supports up to 8 cameras.
4. The GV 4000 hardware design does not limit how multiple cameras are connected. In theory, multiple cameras could be connected through Ethernet switches to each of the GV 4000 camera ports. However, in practice, the effective throughput of the system will decrease as you add more cameras, higher resolution or color formatting. Consult with your Teledyne DALSA representative on applications requiring more than 4 cameras or high inspection speeds. For additional discussion of bandwidth, refer to the Sherlock 7 Install Guide or iNspec Express VA Troubleshooting Guide.

iNspec Express and Sherlock use different software drivers to interface Genie series cameras. iNspec Express uses a driver called IFC, whereas Sherlock uses one called Sapera LT. The setups associated with each will be described later in the manual. Generally, Sapera offers additional flexibility over IFC, but requires additional steps to setup. The PIC-2592 camera uses IFC in both Sherlock and iNspec Express.

Two cables are needed in the setup of each camera. The data cable (A-CAB-GE-X) connects the camera’s Ethernet port to one of the GV 4000 camera ports. The I/O cable provides power to the camera and access to the camera’s I/O, including trigger. When using the PL-USB module (Genie camera breakout module), the standard GEVA cable should be used (A-CAB-GEVA-FX). This method offers more flexibility and greater I/O control. If you are not using the PL-USB breakout module, the standard Genie trigger cable can be used (A-CAB-GTP-X). Choice of one over the other is application dependent.

**Note:** By default, iNspec Express and Sherlock assume Genie camera Input2 is the trigger input and Genie camera Output2 is the strobe output.

## Typical Configuration using the PL-USB module

### NOTES:

1. Power connections not shown. Cameras can be powered by the PL-USB or POE (Power Over Ethernet).
2. Use **A-CAB-GE-X** for camera Ethernet connections.
3. Use **A-CAB-G3-IO-X** for I/O connections between Genie Nano and PL-USB (other cables options page 7). Camera Input2 is the expected trigger, Output2 is the strobe. Cable wiring diagrams appear in the PL-USB Quick Start Guide and PL-USB Install Manual.

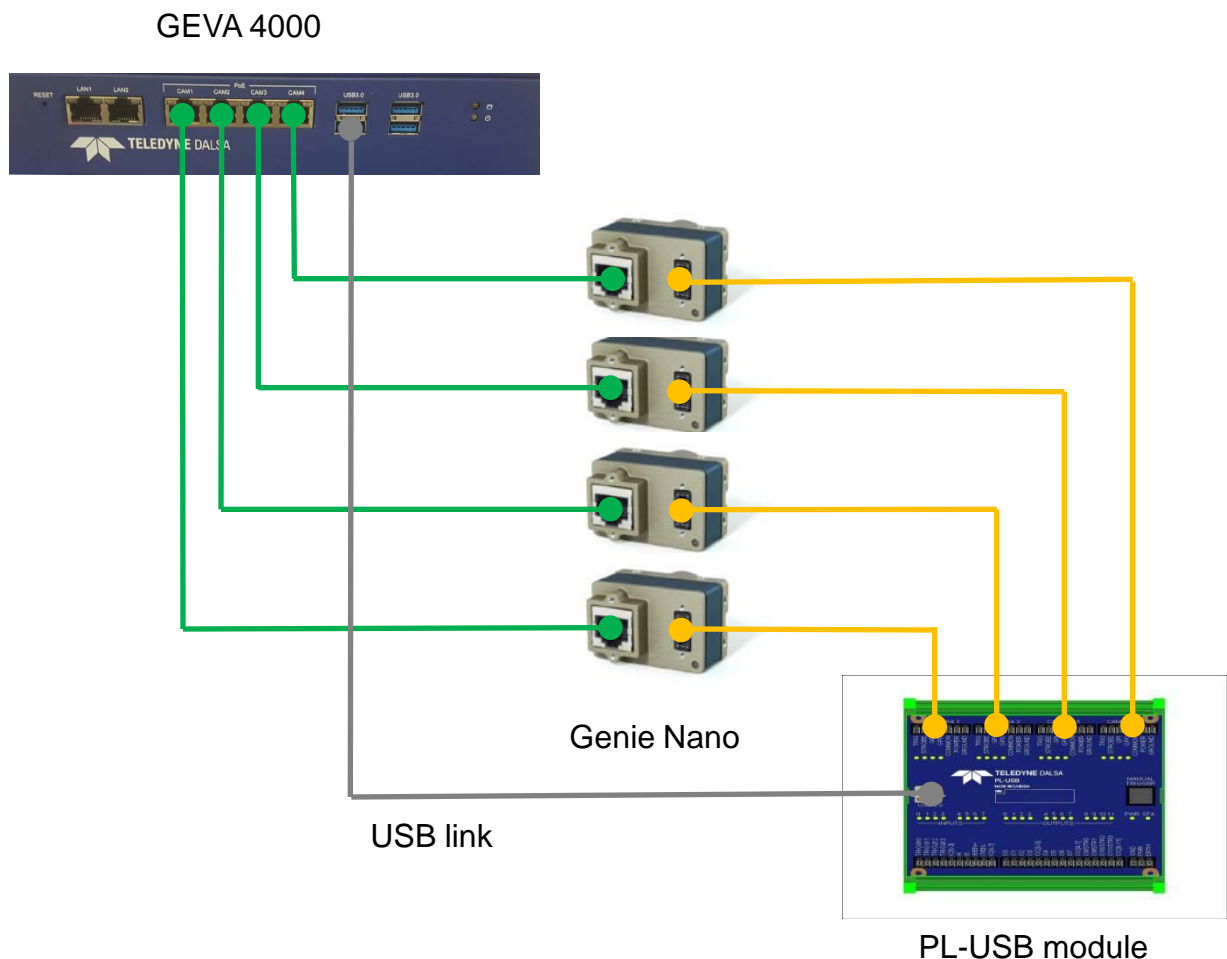

## Typical Configuration using the DCI-101 module

### NOTES:

1. Camera ports 1-4 support POE (Power Over Ethernet).
2. Use **A-CAB-GE-X** for camera Ethernet connections.
3. Use **A-CAB-G3-IO-X** cables for Genie Nano I/O (other cable options page 7). Camera Input1 is the expected trigger. Cable wiring diagrams appear in the DCI-101 Quick Start Guide.
4. Use one **A-DCI-101** for every 2 cameras.

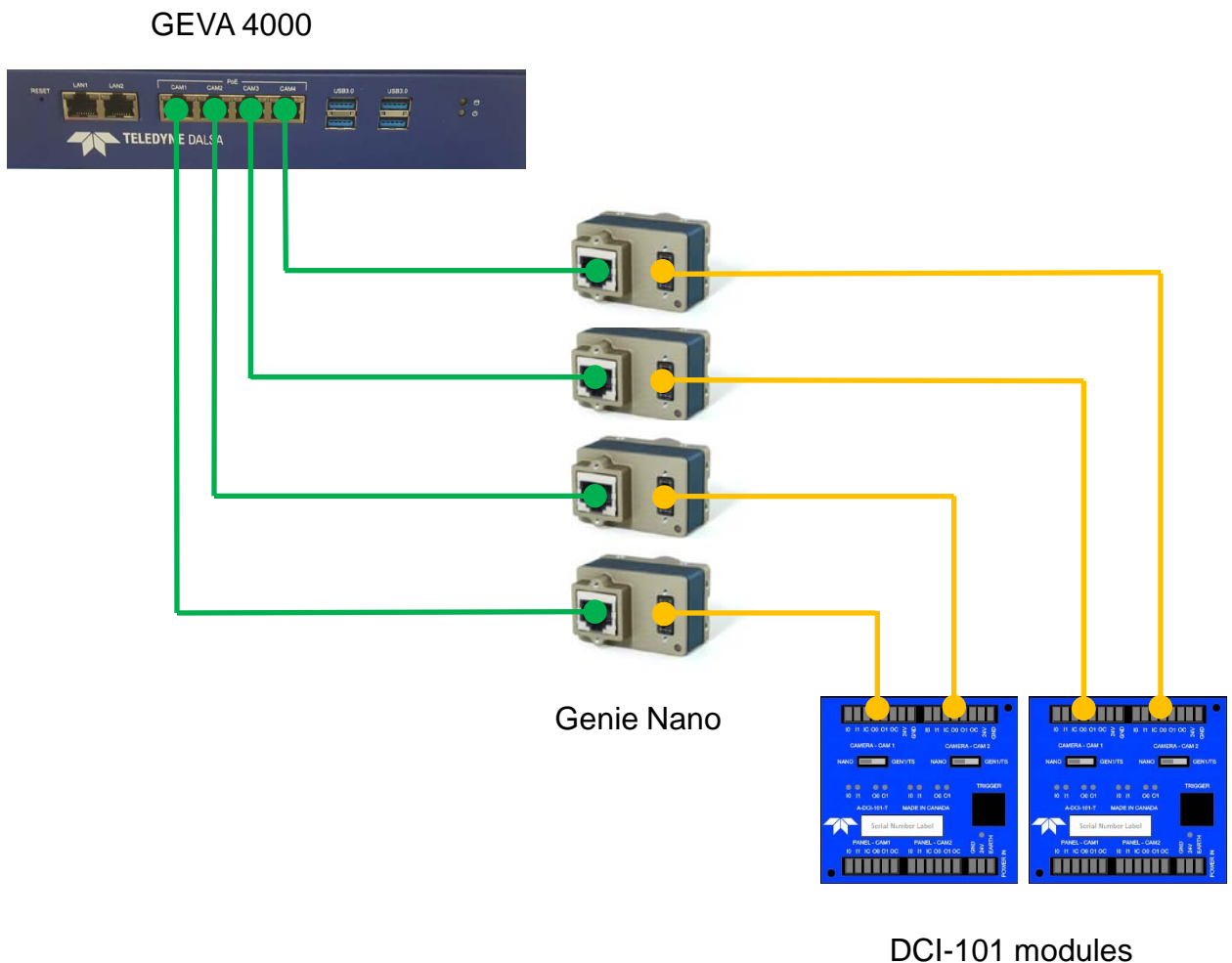



## Getting Started

The GV 4000-03 model ships with iNspect Express installed licensed (not Sherlock). The GV 4000-04 model ships with Sherlock installed licensed (not iNspect Express.) Both models are 64-bit Windows 10 IoT. These applications offers a suite of vision capabilities that satisfy a diverse range of automated inspection needs. The following shows how the GV 4000 is configured, with either interface. Refer to the respective software user manual for more information. Manuals are provided on the GV 4000 drive, and on the iNspect Express CD or Sherlock DVD accompanying the system.

## Software Directory Structure

iNspect Express, Sherlock and associated software applications are installed in various directories on the GV 4000. For reference, the following table lists the location and association of core programs and data directories that are referenced in this manual.

### iNspect Express Program Files and Directories

iNpsect Express Configurator	C:\Program Files\Teledyne Dalsa\iNspectExpress x64\iNspectExpressConfig.exe
iNspect Express	C:\Program Files\Teledyne Dalsa\iNspectExpress x64\Express.bat
Solution Files*	C:\ProgramData\Teledyne Dalsa\iNspectExpressVA\Solutions
iNspect Express Emulator Images*	C:\ProgramData\Teledyne Dalsa\iNspectExpressVA\Images
iDiscover	C:\Program Files\Teledyne Dalsa\iNspectExpress x64\iDiscoverGenie.exe
License Manager	C:\Program Files\Teledyne Dalsa\iNspectExpress x64\lDpLicMgr.exe

### Sherlock Program Files and Directories

Sherlock	C:\Program Files\Teledyne Dalsa\Sherlockx64\bin\lpeStudio.exe
Sherlock Drivers*	C:\ProgramData\Teledyne Dalsa\Sherlockx64\Drivers
Sherlock Programs*	C:\ProgramData\Teledyne Dalsa\Sherlockx64\Programs
Sherlock Emulator Images*	C:\ProgramData\Teledyne Dalsa\Sherlockx64\Images
Sapera Acquisition Wizard	C:\Program Files\Teledyne Dalsa\Sherlockx64\bin\lpeSaqAcqWiz.exe
Sapera CamExpert	C:\Program Files\Teledyne Dalsa\Sapera LT\CamExpert\CamExpert.exe
iDiscover	C:\IPD Install Files\Utilites\iDiscoverGenie.exe
License Manager	C:\Program Files\Teledyne Dalsa\Sherlockx64\bin\lDpLicMgr.exe

- The “ProgramData” paths apply when iNspect Express or Sherlock is installed with the default option “for all users”. The path becomes “Users\Teledyne\AppData\Local” when installed for “current user only”.

**Note:** iNspect Express and Sherlock have a Start Menu shortcut to the User Files directory, which includes \Drivers, \Programs and \Images. The directory C:\ProgramData or C:\Users\Teledyne\AppData (and everything below it) is normally hidden per Windows rules. You can change permissions and hidden folder views.

## The License Manager

The software installed on the GV 4000 is license protected. The license is applied to the unit system number before it ships from the factory. Make sure that the product license matches what you ordered before going any further. Open the license manager from the “start menu” as follows:

Start→All Programs→Teledyne DALSA→iNspect Express for VA→License Manager

Start→All Programs→Teledyne DALSA→Sherlock→License Manager

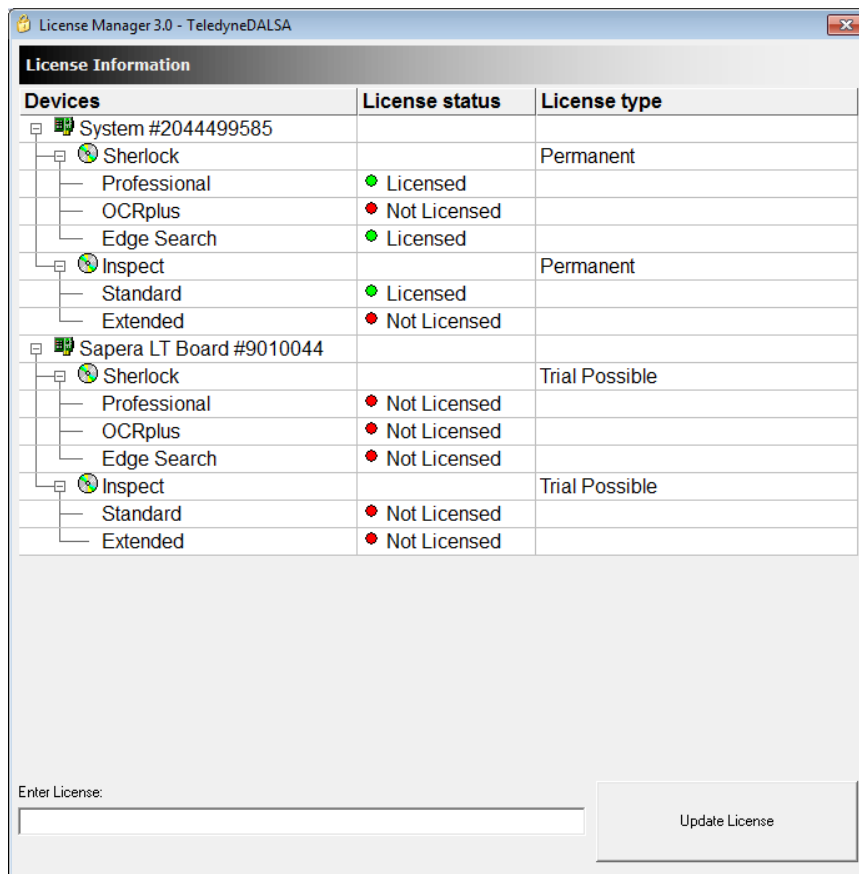

In this example, **both** Sherlock and iNspect Express are licensed. Your system may have only one of these licenses. In this example, “System #2044499585” is the system drive and “Sapera LT Board #9010044” is a Genie Series camera.

If the license does not reflect what you purchased, consult your Teledyne DALSA sales representative. The license is field upgradable by entering a new string in the “Enter License” box.

## iNspect Express Setup

Follow these steps to configure the system to run iNspect Express:

1. Connect cameras as shown in the hardware installation.
2. Verify a valid license is installed (run License Manager).
3. Open the **iNspect Express Configurator** utility and configure preferences; Select “GigE” in the camera menu.
4. Click on the **iDiscover Genie** button to detect and configure cameras connected to the system.
5. Save Camera set (select which connected cameras you want to use).
6. Close iDiscover and launch iNspect Express (run panel shown below).

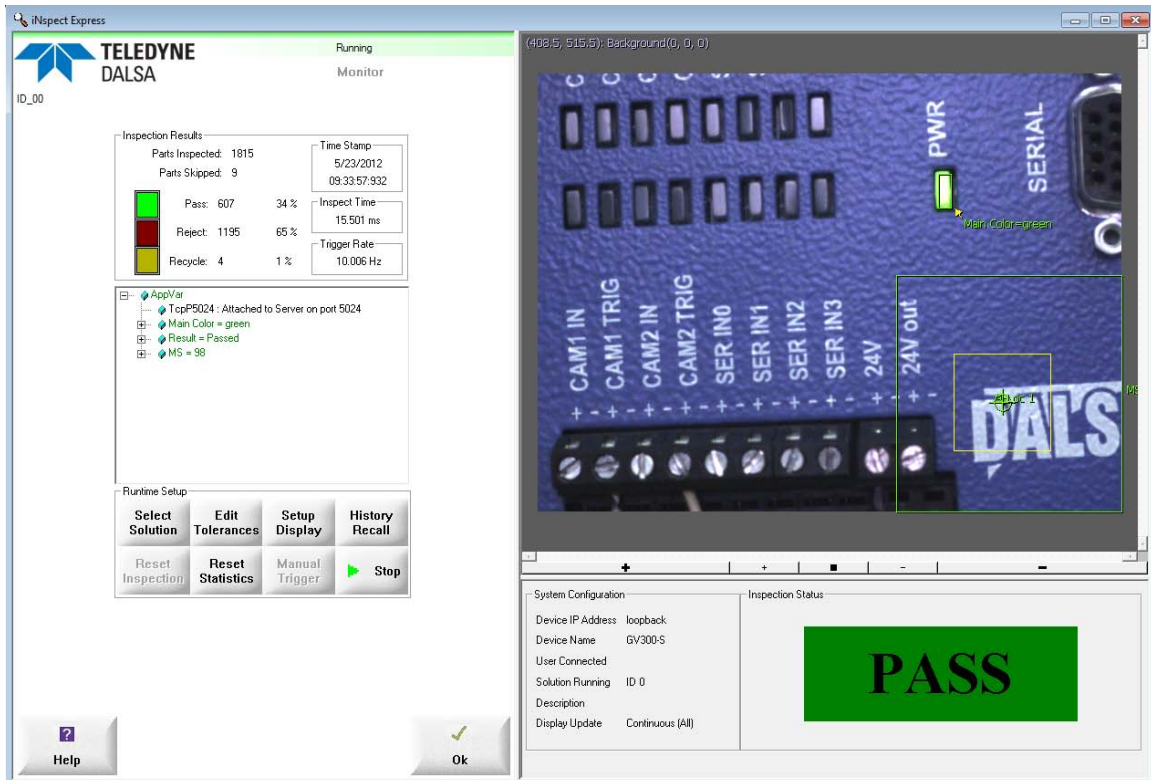

## The iNspec Express Configurator

This program is a front-end configuration tool for iNspec Express. Launch from the icon on the GV 4000 desktop. Select the language, camera type (always GigE for GV 4000) and custom features for your application. These features are peculiar to the iNspec Express software and are detailed in the software users manual.

From the camera selector tool you can launch both iDiscover and iNspec Express as shown below. To launch the emulator simply select the “Emulator” and launch iNspec Express.

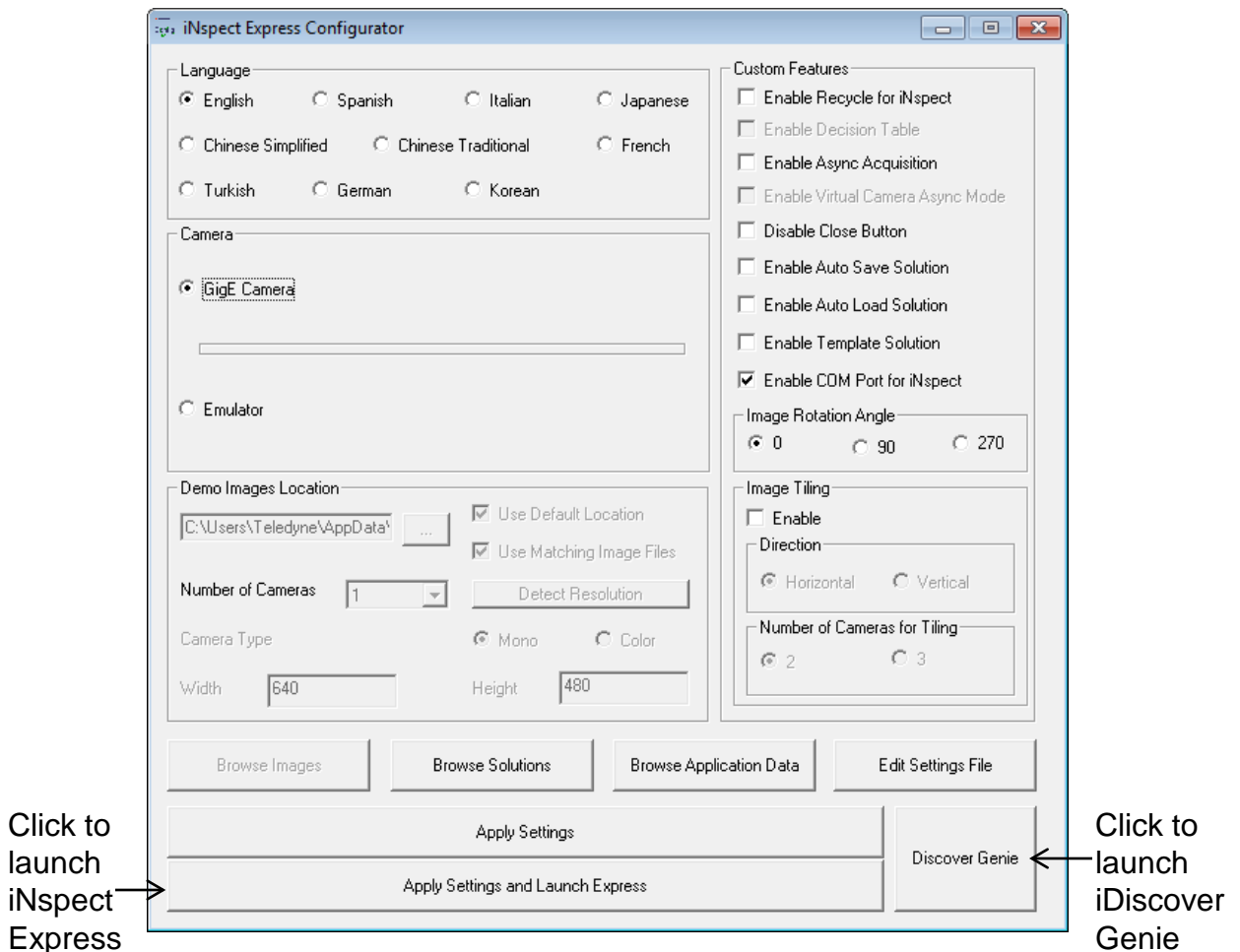

## The iDiscover Utility

The iDiscoverGenie utility is provided for discovering GigE cameras connected to the GV 4000 camera ports. Use the iDiscover interface to change the camera IP settings to match the IP setting of the camera port. A shortcut to the iDiscover program is available on the GV 4000 desktop. This utility applies to both Genie and PIC-2592 cameras.

Click on one of the detected cameras to populate the associated network configuration on the right. You can then modify the camera IP address to match the camera port IP segment at the top. **Note:** Conflicting IP addresses will be designated by a red camera icon in the detected camera menu.

Click the “Apply” button to save changes. The Genie and PIC-2592 cameras will reappear configured at the new address. A Genie TS camera will disappear, and must be rebooted to apply the new address.

Select cameras to use in your iNspec Express configuration by clicking and moving them to the left panel using the arrow buttons. You can change the camera order by using the up/down arrow buttons on the left control bar. Save the corrected camera list.

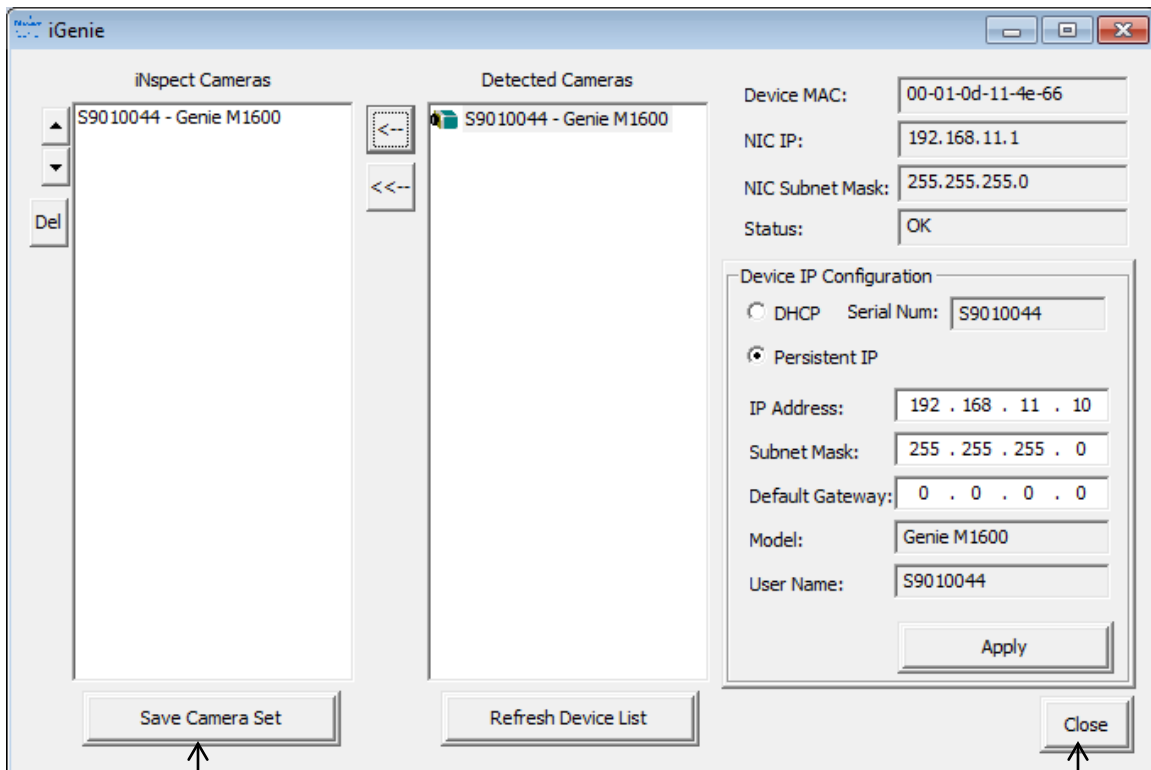

Click to save configuration

Click to return to the Configurator

## Sherlock Setup

Follow these steps to configure the system to run Sherlock:

1. Connect cameras as shown in the hardware installation.
2. Verify a valid license is installed (run License Manager).
3. Run the **iDiscover** program to detect and configure Addresses of all cameras connected to the system (icon shortcut on the desktop).
4. Run the **Sapera CamExpert** utility if you want to change settings in any of the cameras such as exposure, strobe or white balance.
5. Run the **Sapera Acquisition Wizard** to verify all attached GigE cameras are shown as expected and save the configuration file SaperaLTDrv.ini by clicking the “save” button.
6. Launch Sherlock via shortcut on the desktop (Sherlock GUI shown below).
7. Go to the Options menu and select Acquisition. In the “Configure Driver Loading” section enable Sapera for Genie series and PIC2592 cameras.
8. Enable IFC for the PL-USB. Edit the lfcDrv.ini file to point to a valid configuration file. A full path is required. Refer to the PL-USB Installation manual for details.
9. Close and reopen Sherlock. Driver changes only take effect when Sherlock opens.

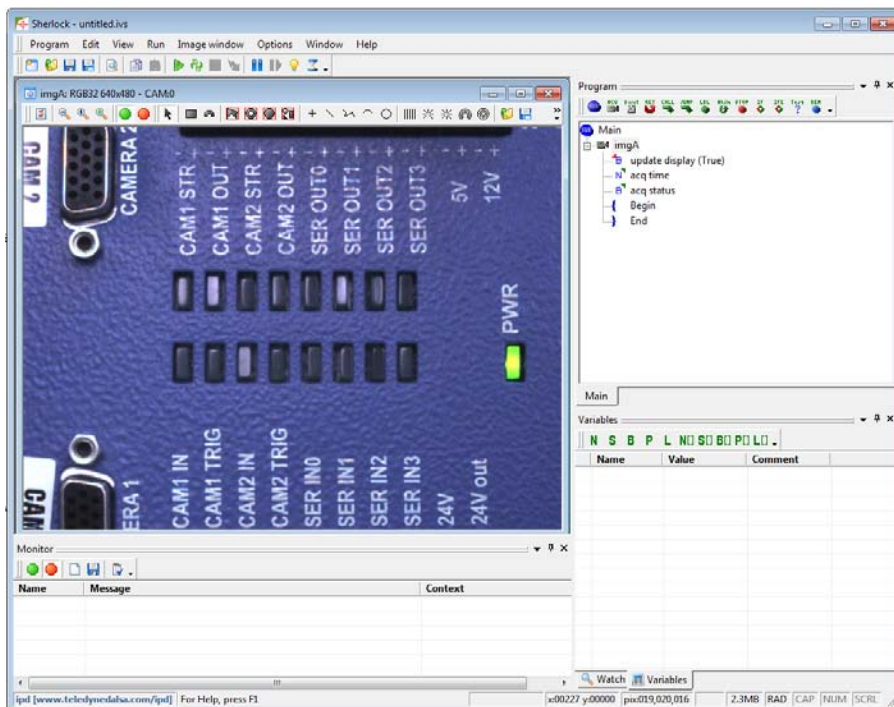

## The Spera CamExpert Utility

GigE cameras store their configuration settings (I/O, shutter speed, white balance) in memory (EEPROM). iNspect Express overrides these settings according to the solution file, whereas Sherlock loads them from the camera or a stored configuration file during program initialization. You can change these parameters and save them on the camera and/or a configuration file using the Spera CamExpert utility.

You can configure the camera to load either your saved settings, or the factory settings, at power up. The preferred method is to save your settings to both the camera and a configuration file. Sherlock can load a configuration file at startup. If multiple configurations are needed, you can save them to different camera configuration files. Some example configuration files are included on the GV 4000.

**Note:** Changes to the camera settings are temporary, unless saved to the camera memory or to a configuration file.

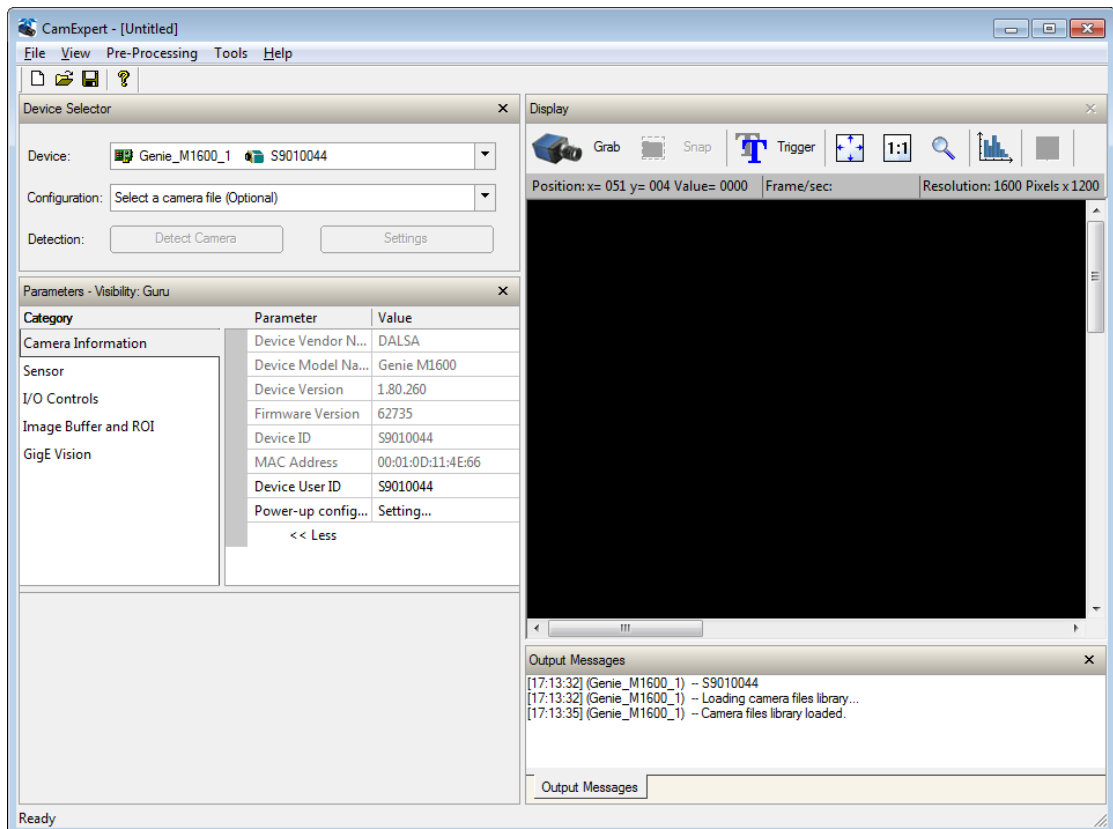

## The Sapera Acquisition Wizard

The Sapera Acquisition Wizard detects all available cameras, and creates a file “SaperaLTDrv.ini” that identifies them in Sherlock. You can enable or disable camera ports, and select camera configuration files using this utility. **NOTE:** If a configuration file does not match the number of cameras, the Sapera LT and Genie drivers will not load and Sherlock will not run saved programs. Instead, Sherlock will open a new investigation (solution) file.

The Sherlock application uses the settings stored in the camera, or in camera configuration files. You can also use Sherlock instructions to change Gain, Exposure (shutter time) or Strobe pulse width (IO:Camera:SetNumberFeature) programmatically.

When you launch the wizard you will see the dialog below. All cameras connected to the GV 4000 should be listed in the device window. Click the “save” button to store the configuration in the SaperaLTDrv.ini file.

The example below shows one Genie M1600 camera. This example is already set to use the Genie camera configuration file from the default location for Sapera LT.

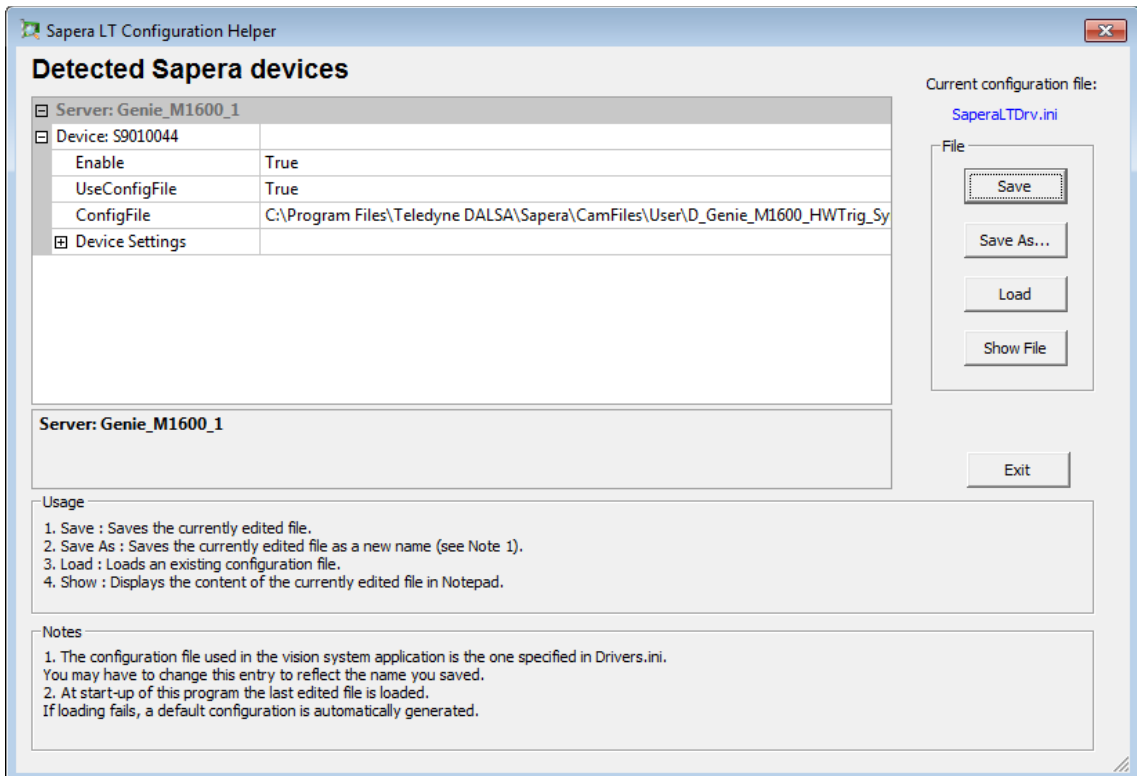

## Changing the Camera Order

The cameras will be seen in Sherlock in the same order as they appear in the SaperaLTDrv.ini file, created by the Sapera Acquisition Wizard. If the order is not to your liking, there are two ways you can correct this.

1. Exit the wizard, disconnect the cameras, and reconnect them in the order you desire. Use the SHOW Status Dialog Box (located in the windows tray at the bottom of your display) to monitor when the cameras are recognized. Open the Sapera Acquisition Wizard and create a new file following the steps above.

2. Save the configuration file from the Acquisition Wizard, and Exit. You can edit the SaperaLTDrv.ini file (found in the Sherlock\Drivers directory) using Notepad.

\* If all cameras are the same type, you can copy and paste the camera names in the correct order.

\* Or, correct the references to "Server0" and "Server1" to match the order you want your cameras to follow. Notice that each "Server#" appears twice in the configuration file. For example: "Server0", "Server0\_Device0", "Server1", "Server1\_Device0".

Each time you run Sherlock it will use the order saved in the SaperaLTDrv.ini file, that is created by the wizard. The order does not change every time the GV 4000 is rebooted.

**Note:** Each time you open the Sapera Acquisition Wizard, the order will change to the order of discovery (or power-on order). If you Click "Save File" the new order will overwrite the saved one, causing the order to change in Sherlock.

## Windows Unified Write Filter

The GV 4000 uses the Windows 10 IoT operating system. This O/S supports an Unified Write Filter (UWF) that provides the ability to write-protect a run-time image. By redirecting all write requests to an overlay disk or RAM partition, UWF allows the run-time image to maintain the appearance of a writeable run-time image. The UWF prevents accidental file corruption when accessing the system or when the system suddenly loses power.

The default state of the UWF is disabled allowing full access to files on the unit. When you have completed development of your application, we recommended enabling the filter to prevent accidental data corruption. When the filter is enabled, only writes to the “AppData” directory will be allowed, all other system and program directories will be blocked.

The UWF is located in the C:\IPD Install Files directory. The utility has a GUI (graphic user interface) for displaying status and setting the filter. Changes take effect on the next system reboot.

**Note:** If you have run the filter and not yet rebooted, it is still showing the current status from when you booted, not what you have set for the next reboot!

## Acronis True Image Software

A backup image was created using the Acronis® True Image Software before your unit was shipped. A “registration form” with an “activation code” was shipped with your unit. [Registration is free](#). You should register with Acronis to obtain a key to unlock this software. Once unlocked, you can create your own backup files on removable media (a USB thumb drive) or a network resource. [We suggest you make your own full backup on a bootable thumb drive](#).

1. Use Windows to make a bootable thumb drive.
2. Use Acronis tools to create a “bootable backup” (you must register first) which deposits the Acronis restore executable onto the drive.
3. Run Acronis to create a full backup on the thumb drive.



## General Specifications

The following table lists the specifications of the GV 4000 vision system.

Specification		Definition
Platform	Processor	Dual Core Gen6 i7-6600U @ 3.4 GHz turbo, (2.6 GHz base)
	OS	Windows10 IoT 64-bit
Memory	Storage	128GB Solid State Drive (SSD)
	Program	16GB DDR3L 1333/1600 MHz non-expandable
Communication	Ethernet	6x Gigabit direct PCIe lanes; 4 ports support POE
	Serial	2x RS-232/343/485 DS-9-pin; COM1 and COM2 with default parameters 11520 baud, 8 data stop bits, no parity, 1 stop bit, no flow control
	USB	4x USB 3.0 front panel, and 2 x USB 2.0 rear panel
	I/O	External via optional PL-USB module
	LED status	2 indicators for Power and HDD
Display	VGA & HDMI Single, Dual or Triple display	1x VGA DS-15-pin female up to 1280x1024, 2x 19-pin HDMI up to 3849x2160@24 Hz or 2560x1600@60 Hz; display supports clone, independent, extended modes
Power	12-30V	60W@24V without POE, 120W@24V with POE.
	2 pin connector	Optional remote ON/OFF button.  Recessed Reset button. Use pointed object to push and hold for 5 seconds.
Cooling	Fanless	Passive heatsink
Mechanical	Material	Machined Aluminum with paint finish
	Mounting	Panel mount adapters and screws included
	Size	210 mm x 60 mm x 143.8 mm (without panel mount)
	Weight	1.94 KG
Environment	Temp	0°C to 40°C Operating -20°C to 70°C Storage
	Humidity	5 to 95% non-condensing
Certification		CE, FCC Class A, RoHS

## GV 4000 Mechanical Dimensions

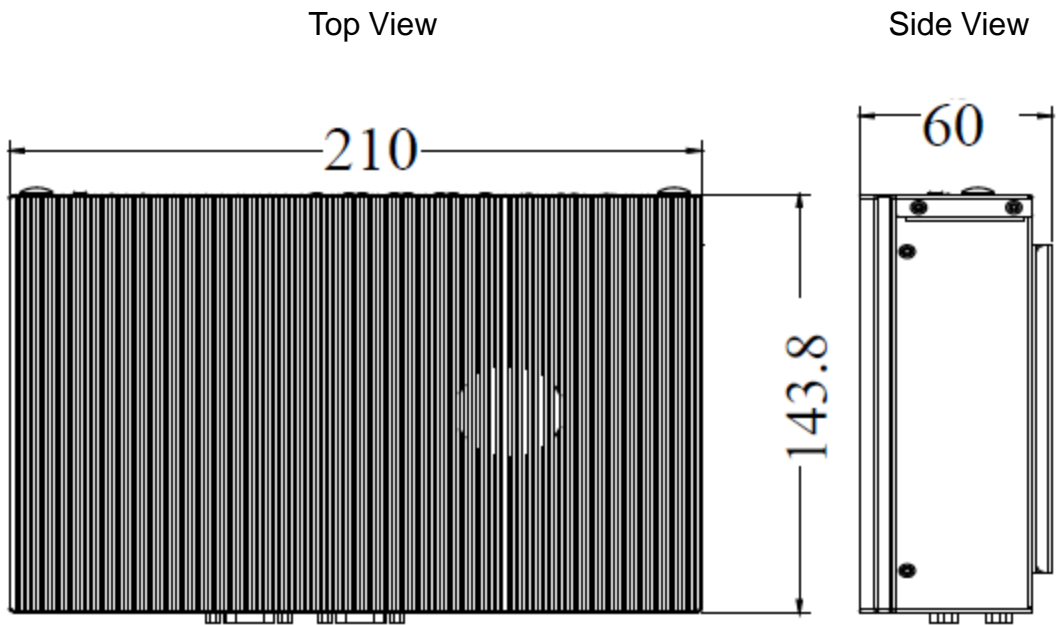

dimensions are in millimeters

## PL-USB Overview

The PL-USB is an external I/O module that can be used with the GV 4000. It provides trigger and power to the connected Genie series cameras as well as I/O for discrete application control. The PL-USB module simplifies hardware setup and provides a consistent I/O solution for iNspect Express and Sherlock. The product is DIN mountable and connects to the GV 4000 through a single USB cable.

The PL-USB can support up to 4 asynchronous and up to 8 synchronous Genie cameras. Refer to the PL-USB Installation Manual for details and camera wiring diagrams. A copy is provided on the GV 4000 system drive, the Sherlock DVD and the iNspect Express CD.

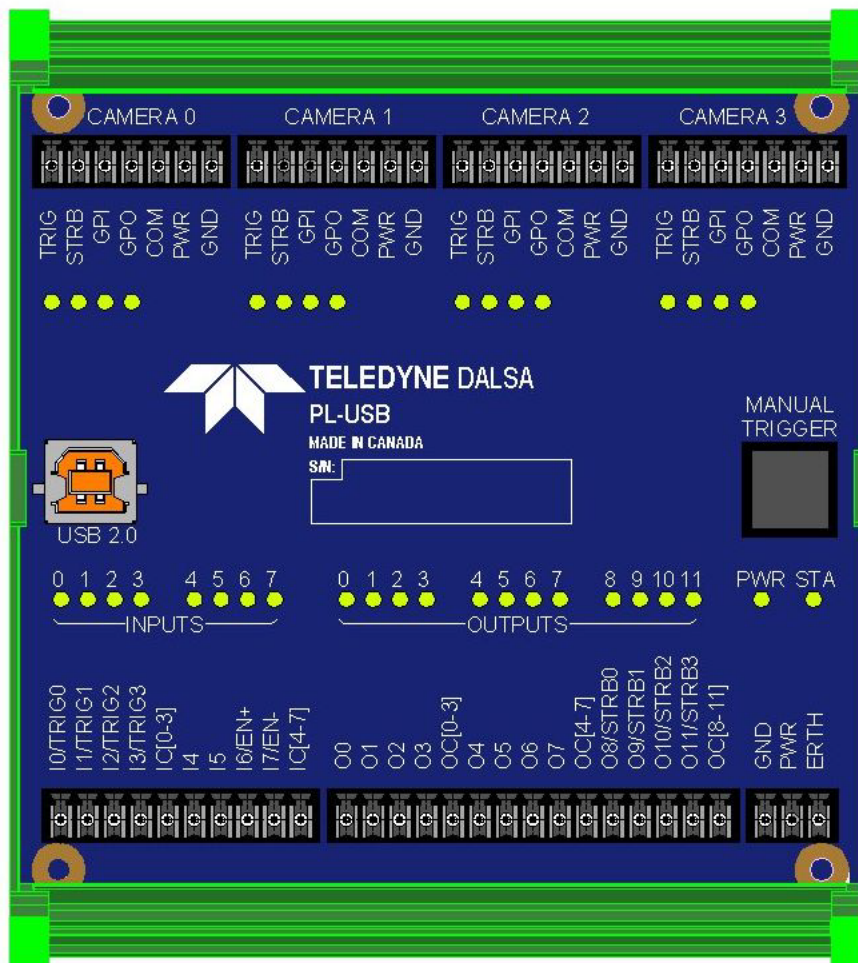

## DCI-101 Overview

The DCI-101 is a breakout module that simplifies wiring between 2 Genie series cameras and the industrial environment. The module mounts inside a control panel alongside the vision controller and related system components.

The DCI-101 offers an isolation barrier for the cameras, a push-button manual trigger and provides convenient LEDs showing the state of camera inputs, outputs and control signals. The module can interface all 3 generations of Genie cameras (24V models).

**Note:** The DCI-101 does not add conditioning (i.e. noise filtering) to the input signals, this is done inside the camera. All inputs and outputs are passed between camera and panel connectors through the isolation barrier. Refer to the DCI-101 Quick Start Guide for details and camera wiring diagrams. A copy is provided on the GV 4000 system drive, the Sherlock DVD and the iNspec Express CD.

