



smart  
vision lights

# ODS75 Brick Light SPOT LIGHT OVERDRIVE™

P R O D U C T D A T A S H E E T



Aluminum Backplate

Four Mounting Holes

High-Intensity LEDs

5-Pin M12 Connector  
(Male)

Power Indicator LED (Green)

Intensity Control (10%–100%)

Signal Indicator LED (Yellow)

**OverDRIVE**

Warranty

**10**  
YEAR

Compliant

**IEC**  
62471

Compliant

**CE**  
RoHS

Rated

**IP**  
50

Connector

**5-PIN**  
M12

## PRODUCT HIGHLIGHTS

- ✓ OverDrive™ — Up to five times brighter than a standard S75 Brick Light
- ✓ 5-pin M12 quick connect
- ✓ Built-in smart driver
- ✓ PNP and NPN trigger signal input
- ✓ Maximum 5000 strobes per second
- ✓ Intensity adjustable from 10%–100% using built-in potentiometer



## PRODUCT INTRODUCTION

The ODS75 Brick Light Series features a smart driver with OverDrive™ strobe mode. The high-intensity LEDs provide an intense but diffuse light pattern at a working distance of up to 4000 mm. This series of lights also offers a manual potentiometer intensity control, allowing the intensity to be adjusted from 10%–100%. A user can also adjust the intensity using the 1–10VDC analog signal line. Heat is dissipated through the aluminum backplate, which allows the ODS75 Series to be run at a higher current and hence greater intensity.

## PRODUCT SPECIFICATIONS

Electrical Input	24VDC +/-5%
Input Current	Max. 2.5 A draw during strobe   Max Average 250 mA
Wattage	Max. 60 W during strobe   Max. Avg. 6.0 W
Strobe Input	PNP : +4VDC or greater to activate   NPN : GND (< 1VDC) to activate
PNP Line	4 mA @ 4VDC   10 mA @ 12VDC   20 mA @ 24VDC
NPN Line	15 mA @ Common (0VDC)
Duty Cycle	Max. strobe duration 10%
Strobe/Pulse Time	Max 5000 strobes per second (SPS)   Max. Single Pulse = 125 ms Protected safe strobe (see SafeStrobe™ Technology for more information)
Red Indicator LED	ON = Light Rest (LED inactive)   OFF = LED/Light Ready
Green Indicator LED	ON = Power
Potentiometer	270° turn pot — intensity control of 10%–100%. Turn clockwise to increases intensity.
Analog Intensity	The output is adjustable from 10%–100% of brightness by a 1–10 V DC signal.
Connection	5-pin M12 connector
Ambient Temperature	-18°–40°C (0°–104°F)
IP Rating	IP50
Weight	~155 g
Compliances	CE, RoHS, IEC 62471
Warranty	UV LEDs have a 2 year warranty, all other LEDs have a 10 year warranty. For complete warranty information, visit <a href="http://smartvisionlights.com/warranty">smartvisionlights.com/warranty</a> .

## WIRING CONFIGURATION

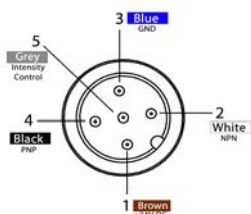

Pin layout for light (Male Connector)

Pin	Function	Signal	Wire Color
1	Power In	+24VDC	BROWN
2	NPN	Sinking Signal	WHITE
3	GND	Ground	BLUE
4	PNP	Sourcing Signal	BLACK
5	Intensity Control	1 - 10VDC	GREY*

\* Some cables use green/yellow for pin 5

For maximum intensity, tie pin 5 to pin 1 at +24VDC.

For continuous mode: Tie PNP (pin 4) can be tied to +24VDC (pin 1) or tie NPN (pin 2) can be tied to Ground (pin 3).

### OPTIONAL

For maximum intensity, connect pin 5 to pin 1 at 24VDC.



# LIGHT PATTERNS

Smart Vision Lights recommends that the ODS75 be used at a working distance between 300 mm and 4000 mm.

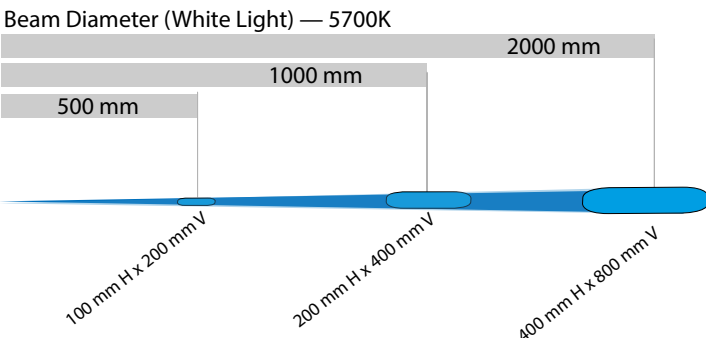
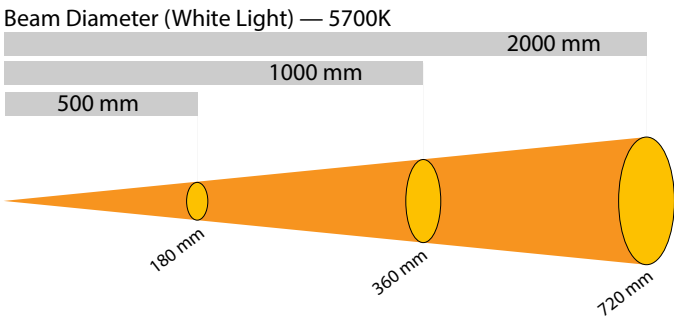
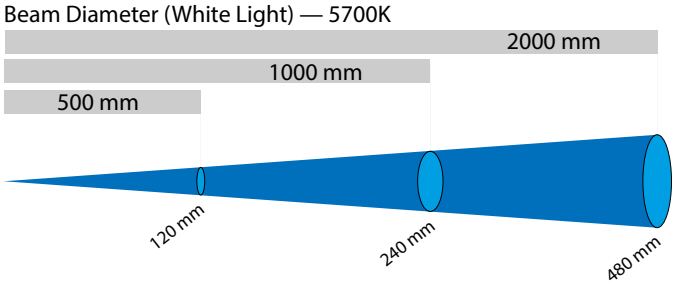

## LIGHTING PATTERN FOR THE ODS75 with Narrow (Standard) Lenses

Working Distance mm (inches)	Pattern (80%–100% measured intensity) mm (inches)
500 mm (19.7")	120 mm (~4.7") D
1000 mm (39.4")	240 mm (~9.4") D
2000 mm (78.8")	480 mm (~18.9") D

Typical Output Performance	Illuminance (Lux)
Distance = 500 mm	36,250
<i>Illuminance measurement taken on White Lights — 5700K</i>	

## LIGHTING PATTERN FOR THE ODS75 with Wide (W) Lenses

Working Distance mm (inches)	Pattern (80%–100% measured intensity) mm (inches)
500 mm (19.7")	180 mm (~7") D
1000 mm (39.4")	360 mm (~14.2") D
2000 mm (78.8")	720 mm (~28.3") D

Typical Output Performance	Illuminance (Lux)
Distance = 500 mm	32,500
<i>Illuminance measurement taken on White Lights — 5700K</i>	

## LIGHTING PATTERN FOR THE ODS75 with Line (L) Lenses

Working Distance mm (inches)	Pattern (80%–100% measured intensity) mm (inches)
500 mm (19.7")	100 mm (~3.9") H x 200 mm (~7.8") V
1000 mm (39.4")	200 mm (~7.8") H x 400 mm (~15.7") V
2000 mm (78.8")	400 mm (~15.7") H x 800 mm (~31.5") V

Typical Output Performance	Illuminance (Lux)
Distance = 500 mm	49,000
<i>Illuminance measurement taken on White Lights — 5700K</i>	

## The ODS75 Brick Light produces a uniform light pattern.

Working Distance = 500 mm Grid set to 25 mm x 25 mm

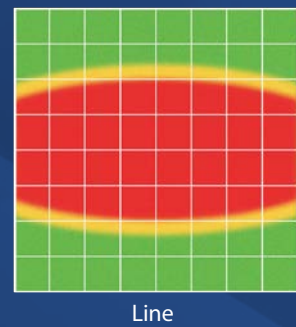
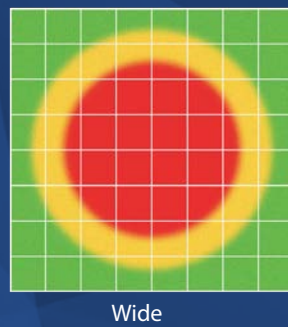
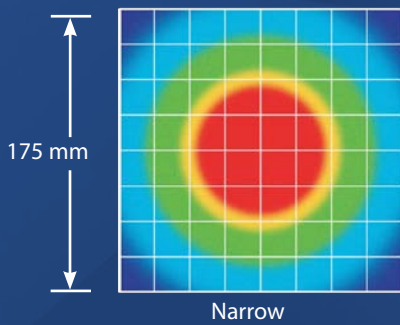

## PRODUCT DRAWING

CAD files available on our website.  
Dimensions are in mm.

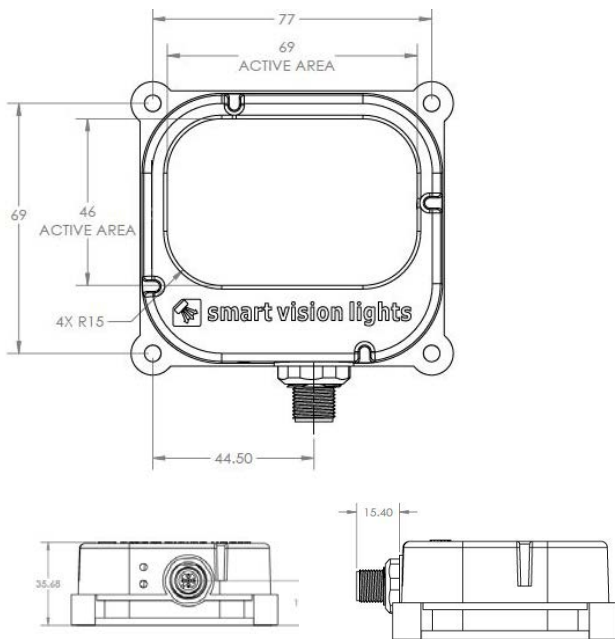

## ILLUMINATION

ODS75 Series of Brick Lights works best for:

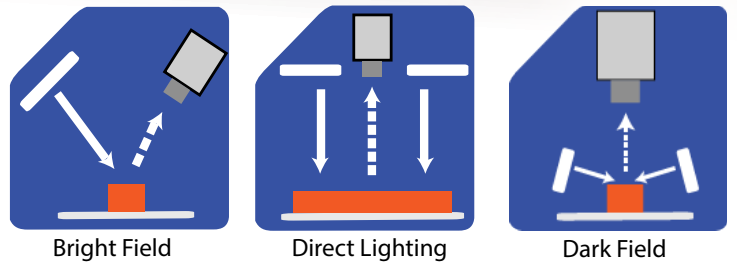

## SAFESTROBE™ TECHNOLOGY

SafeStrobe™ technology applies safe working parameters to ensure high-current LEDs are not damaged when driving them beyond their limits, such as maximum strobe time or duty cycle. This unique technology is especially beneficial for overdriving our high-current LEDs.

## EYE SAFETY

According to IEC 62471: 2006. Full documentation available upon request.



### Notice

**Exempt Group:** No photobiological hazard to eyes or skin even for continuous, unrestricted use. Applicable for wavelengths 625, 850, 940, 1050, 1200, 1300, 1450, and 1550.

### Caution

**Risk Group 1:** Possibly hazardous optical radiation emitted from this product. Do not stare at operating lamp. May be harmful to eyes. Safe for most applications except prolonged exposure. Applicable for wavelengths 470, 505, 530, and WHI.

### Notice

**Risk Group 1:** UV emitted from this product. Minimize exposure to eyes and skin. Use appropriate shielding. Safe for most applications except prolonged exposures. Applicable for wavelength 395.

### Caution

**Risk Group 2:** UV emitted from this product. Eye or skin irritation may result from exposure. Use appropriate shielding. Does not pose optical hazard if aversion responses limit exposure. Applicable for wavelength 365.

## PART NUMBER

ODS75 - [ ] [ ] [ ] [ ] - [ ] - [ ] [ ] [ ]

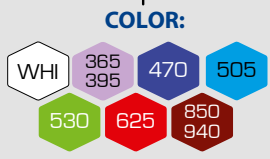

**LENS:**  
 Leave blank for Standard (Narrow)  
 W = Wide  
 L = Line

**LINEAR POLARIZER:**  
 Leave blank for none  
 LPI = Factory Installed

### Part Number Examples:

- ODS75-625** ODS75, 625 nm Red Wavelength, Standard (Narrow) Lens
- ODS75-WHI-L** ODS75, White, Line Lens
- ODS75-470-W-LPI** ODS75, 470 nm Blue Wavelength, Wide Lens, with Linear Polarizer installed

*Additional wavelengths and lens options available upon request.*



This light is available in our SWIR LEDs.



## LENS OPTICS

### NARROW (STANDARD)

Narrow, 10° angle-cone lenses are standard. Standard lenses project a narrow beam of illumination and are used for long working distances.



### WIDE

Wide, 25° angle-cone lenses project a large area of illumination. They create a floodlight effect, can be used for short working distances.

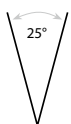

### LINE

Line, with a 10° width and a 50° fan-angle project a thin, narrow beam of illumination.

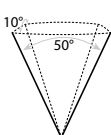

*\*Additional lens options available upon request.*

### When To Use a Linear Polarizer?

Polarizing filters can reduce reflections on specular surfaces.

A Linear Polarizer has a typical transmission of 38 percent while blocking 62 percent of the light not in the polarization plane.

**WARNING:** Running a light in continuous operation while using a standard polarizer with certain wavelengths (e.g. white, blue) may burn the polarizer.

## DUTY CYCLE

The Duty Cycle (D) is related to the Strobe Time (ST) and Rest Time (RT).

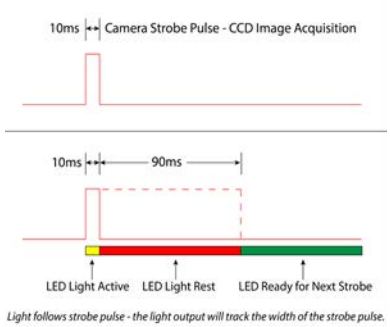

### Calculating Rest Time

$$RT = \frac{ST}{D} - ST$$

RT = Rest Time  
 ST = Strobe Time  
 D = Duty Cycle

**Example**  
 $90 \text{ ms} = \frac{10 \text{ ms}}{.1} - 10 \text{ ms}$   
 Rest Time is 90 ms for 10 ms Strobe Time

### Calculating Strobe Rate

$$SR = \frac{D}{ST}$$

SR = Strobe Rate (strokes per second)  
 ST = Strobe Time (seconds)  
 D = Duty Cycle

**Example**  
 $1000 = \frac{0.1}{0.0001}$   
 Strobe Rate is 1000 strokes per second

### Calculating Duty Cycle

$$D = ST \times SR$$

SR = Strobe Rate (strokes per second)  
 ST = Strobe Time (seconds)  
 D = Duty Cycle

**Example**  
 $0.1 = 0.0001 \times 1000$   
 Duty Cycle is 10% (0.1)

**Maximum Duty Cycle for OverDrive™ light is 10% (0.1)**

*Note: Strobe time is limited by the strobe rate.*

# MOUNTING

Mounting options on the ODS75 Series Brick Light include four holes. See Accessories for additional mounting options.

Example of the ODS75 shown using the Pan and Tilt Mount (Part Number: PB75-M5).

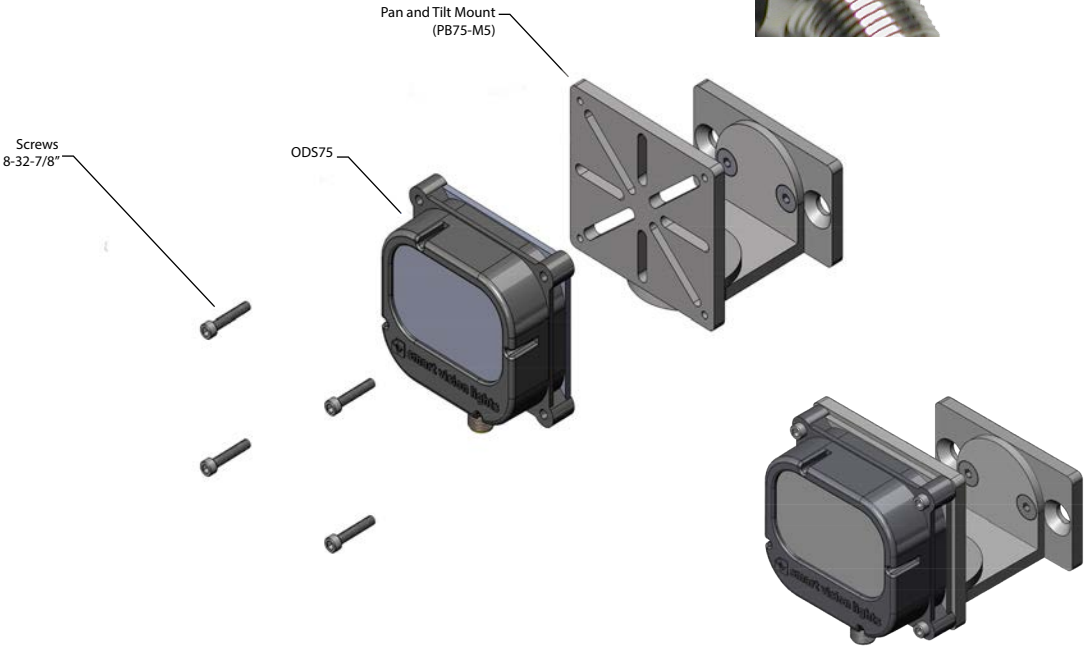



## ACCESSORIES

### Power Cables



Length	Part Number
5 m	5PM12-5
10 m	5PM12-10
15 m	5PM12-15

### Mount



Description	Part Number
Pan and Tilt Mount	PB75-M5

### Mounting Rails



Length	Part Number
300 mm	LEXT300
600 mm	LEXT600
900 mm	LEXT900
1200 mm	LEXT1200
Custom sizes available	

### Diffuser



Description	Part Number
Diffuser Kit for OD75	ODS75-DKIT

### Linear Polarizer



Description	Part Number
Linear Polarizer for ODS75	ODS75-LP

### Pulse Modules



Description	Part Number
Pulse Generator Module	PGM
Pulse Timing Module	PTM



## GLOSSARY

This glossary covers all Smart Vision Lights product families; some content in this section may not apply to this specific light.

### TERMINOLOGY

**OverDrive™** Light includes an integrated high-current strobe driver for complete LED light control.

**Continuous Operation** Light stays on continuously.

**Multi-Drive™** Combines continuous operation and OverDrive™ strobe (high-current strobe operation) modes into one easy-to-use light.

**Built-In Driver** The built-in driver allows full function without the need for an external driver.

**Camera to Light** Connect the light directly to the camera, without the need for additional controllers or equipment.

**Polarizers** Filters that reduce reflections on specular surfaces.

**Diffuser** Used to widen the angle of light emission, reduce reflections, and increase uniformity.

### TYPES OF ILLUMINATION

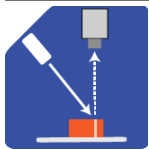

Projector

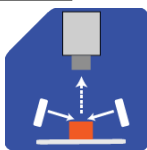

Dark Field

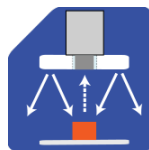

Radial



Bright Field

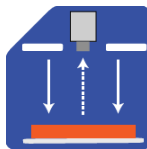

Direct

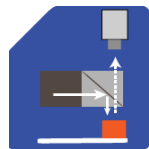

Axial

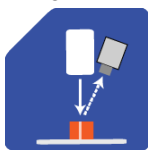

Line

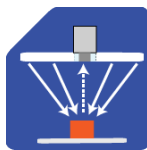

Diffuse Panel

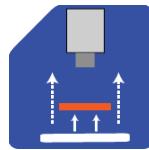

Backlight

### COLOR/WAVELENGTHS LEGEND

Wavelength options range from 365 nm to 1550 nm. Additional wavelengths available for many light families.

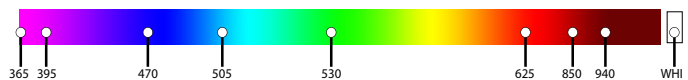

See Part Number section for **this light's** available standard wavelengths.



Shortwave infrared LEDs are available in 1050 nm, 1200 nm, 1300 nm, 1450 nm, and 1550 nm.

Check Part Number section to see if **this light** is available in SWIR wavelengths.