

ZQ1 Quick Start Guide

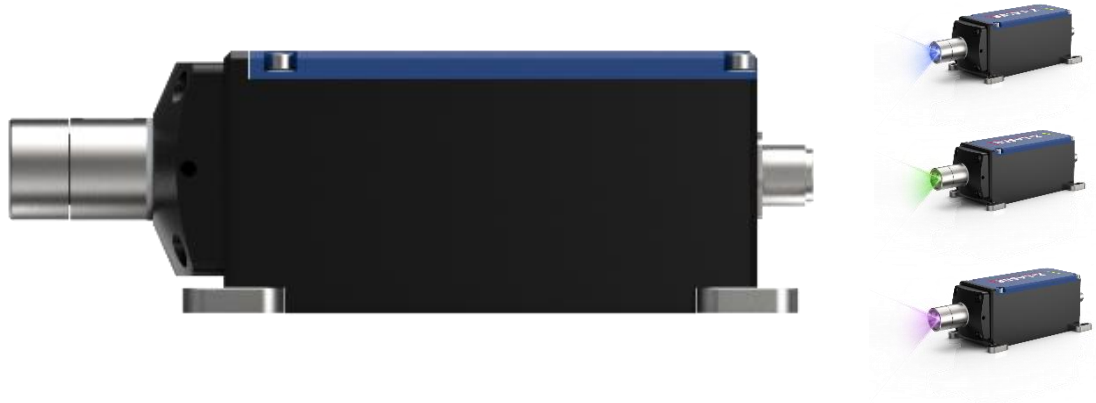

Introduction

This is a quick start guide for industrial applications. For all details refer to the User's Manual (or advanced information). Please download the User's Manual from www.z-laser.com or contact our sales team.

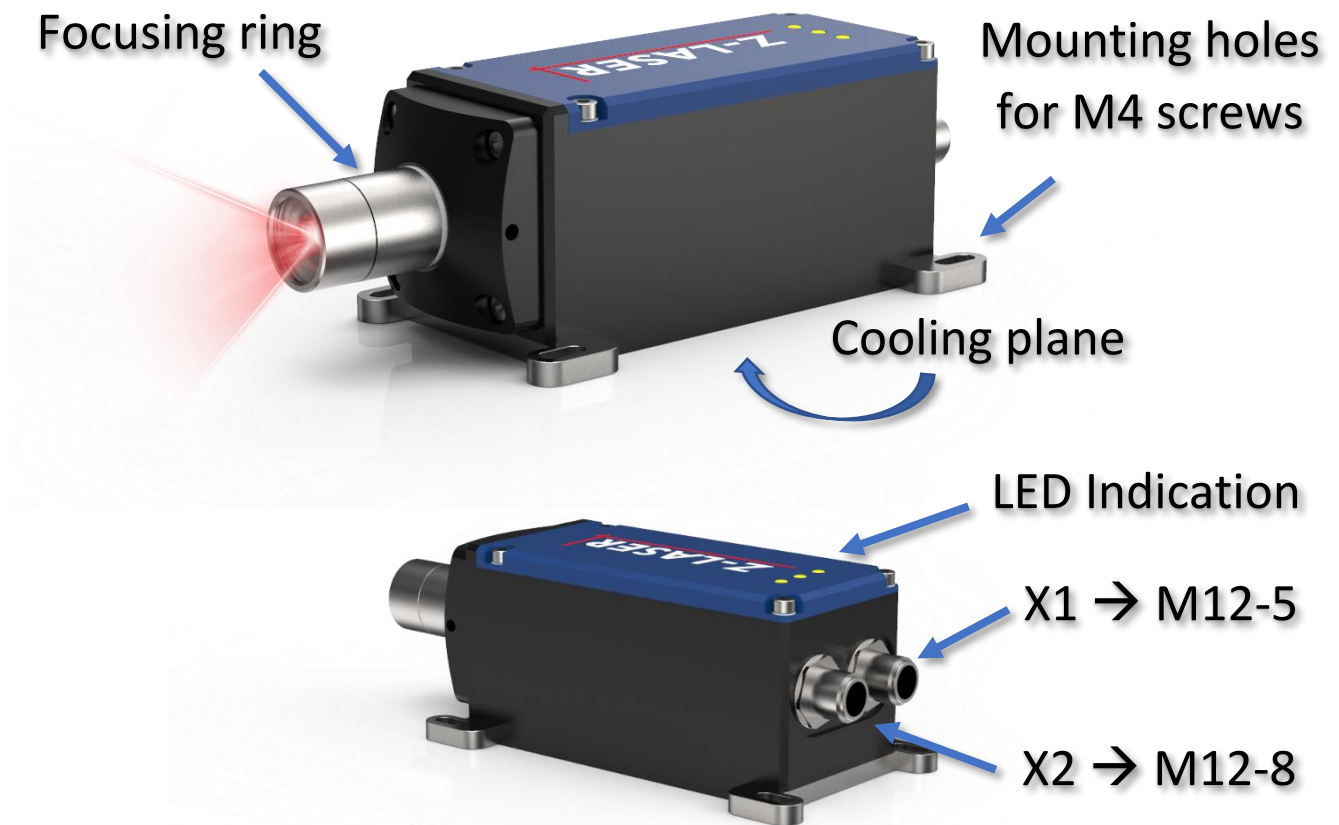

Thermal dissipation

An active, or very good passive, cooling capability must be provided and attached to the marked cooling plane. **Up to 35 W of thermal power must be dissipated.**

Handling of the product

- Provide sufficient cooling capabilities. Up to 35 W of thermal power must be dissipated. Mount the laser according to the designated cooling planes using heat conducting compound.
- Use all four mounting screws (not supplied) to provide sufficient thermal contact between base plane and heat sink.
- Base plane is 0.1mm higher than the mounting holes planes.
- Please do not disassemble the ZQ1 laser module.
- Electrical power supply and operation control signaling must be provided according to instructions given in the user's manual.
- Remove the black protection cap in front of the laser, before turning the laser light ON.
- The IP-67 protection is ensured only when both M12 Connector are plugged in and teased.

Operating the laser module

Please be certain that before operating the laser module you have taken all aspects of laser safety into consideration. (Refer to Chapter 15 of the user's manual). Keep the safety cap closed at the laser output or mount it in fixed position in front of a photo detector. Make sure that no human being is accidentally exposed to laser radiation.

First steps to a basic operation of the laser module could be as follows:

1. Be certain that the "ZQ1" laser module is assembled correctly and mounted on a proper heat sink. Mounting must be flat and air gaps should be avoided by using heat sink compound.
2. Prepare a proper cabling for X1 and X2, refer to chapter 0 of the user's manual for details.
3. Connect a 12-24 VDC power supply to the X1 connector. Be sure it can source more than 40 Watt.
4. Connect X1.2 and apply appropriate signals (TTL Level, protected up to 24VDC) to the digital trigger input to switch the laser on (green LED starts blinking).
5. * By default, is System Enable not active. If activated from user, please connect additionally short X2.6 and X2.8 to switch the laser light on.

X1 Power Connector

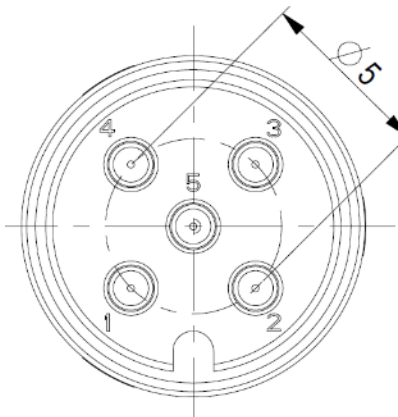

M12 5-Pin A-Coding Male Connector

According to IEC 61076-2-101

- X1.1 VCC (12-24 Volt, capable of sourcing 40 VA)
- X1.2 Digital-Modulation (TTL signaling level related to Signal-GND)
- X1.3 GND
- X1.4 Analog Modulation (0-2V signaling level related to Signal-GND)
- X1.5 Fail Out (not yet implemented)

X2 Communication Connector

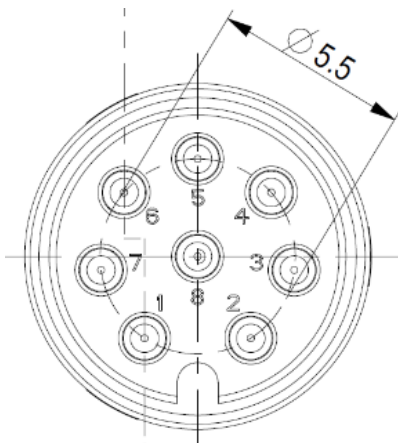

M12 8-Pin A-Coding Male Connector

According to IEC 61076-2-101

- X2.1 RX IN (RS232)
- X2.2 TX OUT (RS232)
- X2.3 SCL (I2C)
- X2.4 SDA (I2C)
- X2.5 RDY FAIL OUT
- X2.6 System Enable OUT
- X2.7 GND
- X2.8 System Enable IN

Cables

The optionally included cables have the following color pin assignment:

M12-8

- 1 → White
- 2 → Braun
- 3 → Green
- 4 → Yellow
- 5 → Grey
- 6 → Pink
- 7 → Blue
- 8 → Red

M12-5

- 1 → Braun
- 2 → White
- 3 → Blue
- 4 → Black
- 5 → Grey

Graphical User Interface

For an exhaustive access to system data and controls you should download and install the ZQ1 remote control software from:

<http://www.z-laser.com>

Please refer to the *ZQ1 User's Manual* for further help. (available on the USB Stick or contact our Sales)

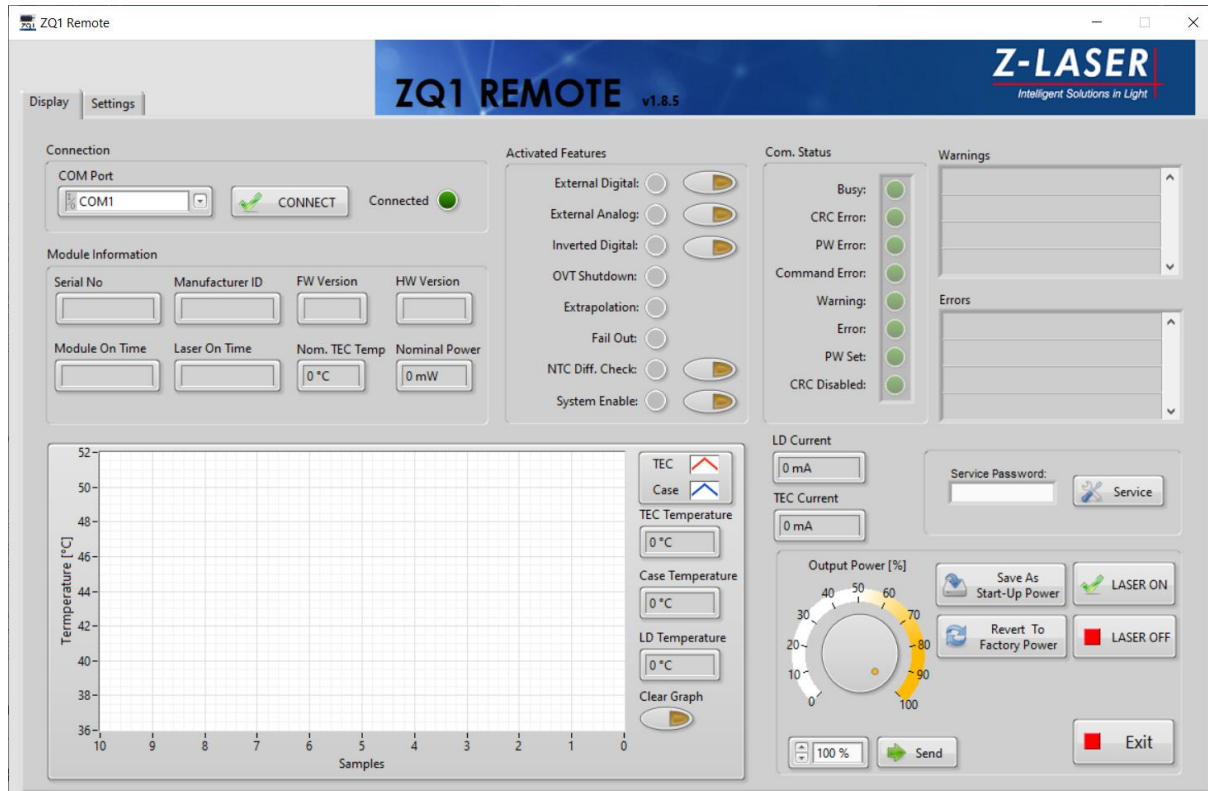

Information:

- Module and Laser On-Time
- Serial Number
- FW and HW Version
- Nominal Power
- LD and TEC Current
- Tracking Case, LD and TEC Temperature
- Warning and Error Visualization

Setup:

- Adjust Output Power between 0-100% (0% → ca. 10mW)
- Activation multiple features
 - Laser ON / OFF
 - External digital and analog Modulation
 - Inverted digital Modulation
 - System Enable

LED Indication



-  → Warning Indication (continuous wave)/Failure Indication (blink operation)
-  → Laser ON Indication (laser light emitted)
-  → Blink Codes Indication for different warning/failure identification.

Table 1 Error Codes Description.

Pos	Green LED	Red LED	Warning
1	Blink Code 1	Blink 2Hz	TEC Driver Error
2	Blink Code 2	Blink 2Hz	Flash/EEPROM/RAM/CPU/Watchdog Check Error
3	Blink Code 3	Blink 2Hz	Peltier Verification Error
4	Blink Code 4	Blink 2Hz	Watchdog Reset Error
5	Blink Code 5	Blink 2Hz	Set Power Error CMD Execution Error TWI Error UART Error
6	Blink Code 6	Blink 2Hz	Case Over/Under Temperature Error
7	Blink Code 7	Blink 2Hz	Over/Under Current Error
8	Blink Code 8	Blink 2Hz	Laser Diode Over/Under Temperature Error
9	Blink Code 9	Blink 2Hz	RAM Variable Error
10	Blink Code 10	Blink 2Hz	Calibration Table/Missing Calibration Error
11	Blink Code 13	Blink 2Hz	Start Up Test Error
12	Blink Code 15	Blink 2Hz	Interpolation Table Error
13	Blink Code 16	Blink 2Hz	NTC Difference Error

Table 2 Warning Codes Description

Pos	Green LED	Red LED	Warning
1	Blink Code 2	LED ON	End of Life Warning
2	Blink Code 4	LED ON	System Enable Warning
3	Blink Code 5	LED ON	Invalid CMD Frame Warning CMD Out of Range Warning Access Violation Warning
4	Blink Code 6	LED ON	Case Over/Under Temperature
5	Blink Code 7	LED ON	Extrapolation Warning
6	Blink Code 8	LED ON	Laser Diode Over/Under Temperature Warning
7	Blink Code 10	LED ON	No Calibration/Cal_Temp_MIN_MAX_Limit Warning
8	Blink Code 12	LED ON	Over 24 hours ON time Warning
9	Blink Code 13	LED ON	TEC Current Warning

Product Labelling

This "ZQ1" product is labelled as follows. If one of these labels is missing, do not operate the laser.

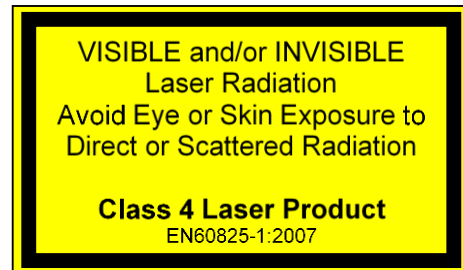
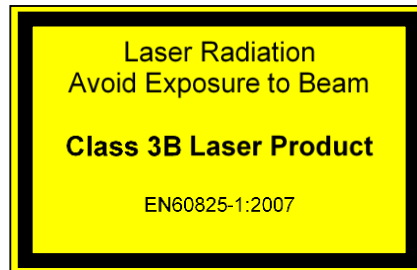

Z-Laser declares the conformity to a laser safety class according to EN ISO 60825-1 only for the complete product entity. Whenever this entity is changed the laser safety class is voided.

CAD Drawing

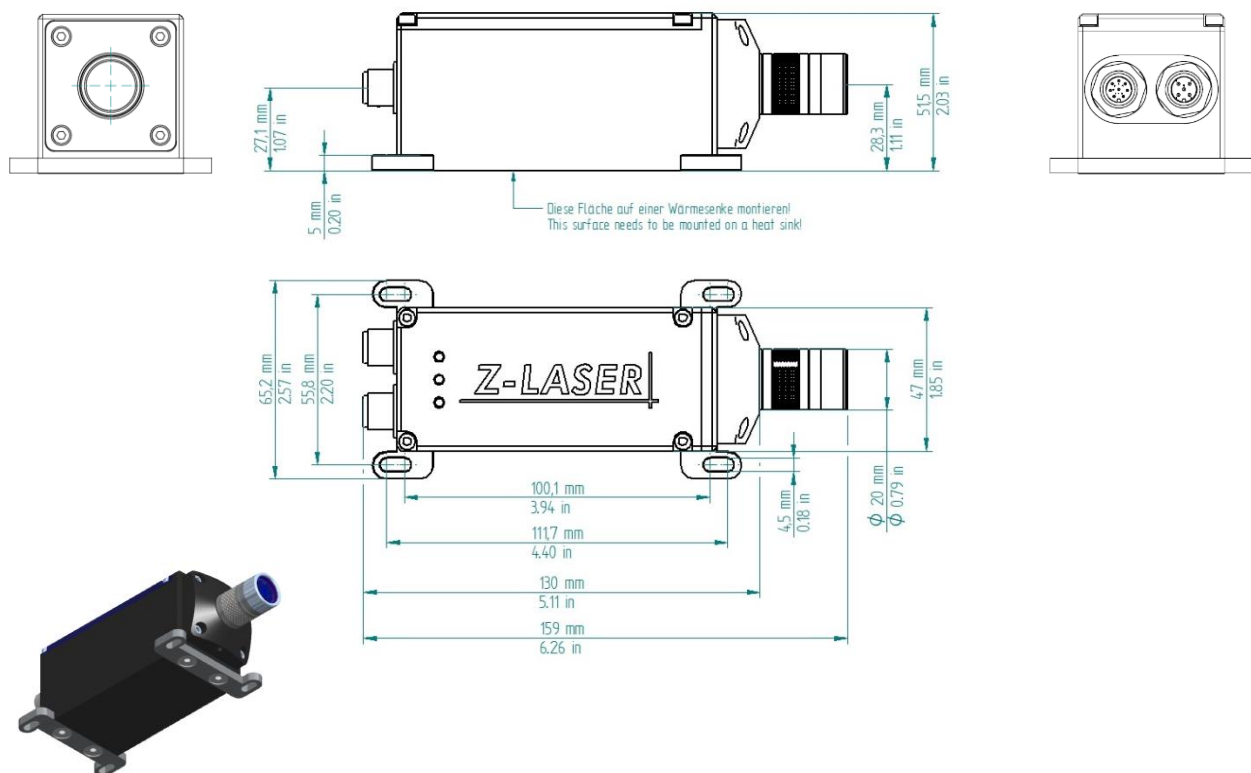

Version	Date	Product Family	Author
1.7	22.04.2021	ZQ1	G. Todorov