



USER MANUAL

Gocator Point Profile Sensors

Gocator 1300 Series

Firmware version: 5.3.x.xx

Document revision: B

Copyright

Copyright © 2019 by LMI Technologies, Inc. All rights reserved.

Proprietary

This document, submitted in confidence, contains proprietary information which shall not be reproduced or transferred to other documents or disclosed to others or used for manufacturing or any other purpose without prior written permission of LMI Technologies Inc.

No part of this publication may be copied, photocopied, reproduced, transmitted, transcribed, or reduced to any electronic medium or machine readable form without prior written consent of LMI Technologies, Inc.

Trademarks and Restrictions

Gocator™ is a registered trademark of LMI Technologies, Inc. Any other company or product names mentioned herein may be trademarks of their respective owners.

Information contained within this manual is subject to change.

This product is designated for use solely as a component and as such it does not comply with the standards relating to laser products specified in U.S. FDA CFR Title 21 Part 1040.

Contact Information

LMI Technologies, Inc.
9200 Glenlyon Parkway
Burnaby BC V5J 5J8
Canada

Telephone: +1 604-636-1011

Fax: +1 604-516-8368

www.lmi3d.com

Table of Contents

Copyright	2
Table of Contents	3
Introduction	11
Gocator Overview	12
Safety and Maintenance	13
Laser Safety	13
Laser Classes	14
Precautions and Responsibilities	15
Class 3B Responsibilities	15
Nominal Ocular Hazard Distance (NOHD)	16
Systems Sold or Used in the USA	16
Electrical Safety	17
Handling, Cleaning, and Maintenance	17
Environment and Lighting	18
Getting Started	19
Hardware Overview	20
Side Mount Package	20
Top Mount Package	20
Gocator Cordsets	21
Master 100	22
Master 400 / 800 / 1200 / 2400	22
Master 810 / 2410	24
Alignment Targets	25
System Overview	27
Standalone System	27
Dual-Sensor System	28
Multi-Sensor System	28
Installation	30
Mounting: Side Mount Package	30
Mounting - Top Mount Package	31
Orientations	32
Cordset Bend Radius Limits	34
Grounding	36
Gocator	36
Recommended Practices for Cordsets	36
Master Network Controllers	37
Grounding When Using a DIN Rail (Master 810/2410)	38
Additional Grounding Schemes	38
Installing DIN Rail Clips: Master 810 or 2410	39

Configuring Master 810	40
Setting the Divider	41
Encoder Quadrature Frequency	41
Setting the Debounce Period	42
Network Setup	43
Client Setup	43
Gocator Setup	45
Running a Standalone Sensor System	45
Running a Dual-Sensor System	46
Required Ports	48
Next Steps	49
How Gocator Works	51
3D Acquisition	51
Clearance Distance and Measurement Range	52
Resolution and Accuracy	52
Z Resolution	52
Z Linearity	53
Range Output	54
Coordinate Systems	54
Sensor Coordinates	54
System Coordinates	54
Data Generation and Processing	56
Profile Generation	56
Part Detection	56
Measurement	57
Output and Digital Tracking	57
Gocator Web Interface	58
Browser Compatibility	58
Internet Explorer 11 Issues	58
Internet Explorer Switches to Software Rendering	58
Internet Explorer Displays "Out of Memory"	58
User Interface Overview	59
Toolbar	61
Creating, Saving and Loading Jobs (Settings)	61
Recording, Playback, and Measurement Simulation	62
Recording Filtering	65
Downloading, Uploading, and Exporting Replay Data	66
Metrics Area	68
Data Viewer	69
Status Bar	69

Log	69	Material	105
Frame Information	70	Material Settings and Dynamic Exposure	105
Quick Edit Mode	70	Alignment	106
Interface Language	71	Alignment Types	106
Management and Maintenance	72	Aligning Sensors	107
Manage Page Overview	72	Encoder Calibration	110
Sensor System	73	Clearing Alignment	110
Dual- and Multi-sensor Systems	73	Filters	110
Buddy Assignment	73	Gap Filling	111
Over Temperature Protection	74	Median	112
Sensor Autostart	75	Smoothing	112
Layout	75	Decimation	113
Networking	78	Slope	114
Motion and Alignment	79	Profile Generation	115
Alignment Reference	80	Part Detection	118
Encoder Resolution	80	Data Viewer	120
Encoder Value and Frequency	81	Data Viewer Controls	120
Travel Speed	81	Video Mode	121
Jobs	81	Spots and Dropouts	121
Security	83	Range Mode	122
Maintenance	84	Profile Mode	123
Sensor Backups and Factory Reset	85	Region Definition	125
Firmware Upgrade	86	Intensity Output	126
Support	87	Measurement and Processing	127
Support Files	88	Measure Page Overview	127
Manual Access	89	Data Viewer	127
Software Development Kit	89	Tools Panel	129
Scan Setup and Alignment	90	Adding and Configuring a Measurement	
Scan Page Overview	90	Tool	129
Scan Modes	91	Source	130
Triggers	91	Regions	130
Trigger Examples	95	Feature Points	131
Trigger Settings	96	Geometric Features	133
Maximum Input Trigger Rate	98	Fit Lines	134
Maximum Encoder Rate	98	Decisions	134
Sensor	98	Filters	136
Active Area	98	Measurement Anchoring	137
Transformations	100	Enabling and Disabling Measurements	140
Exposure	101	Editing Tool, Input, or Output Names	141
Single Exposure	102	Changing a Measurement ID	142
Dynamic Exposure	102	Duplicating a Tool	142
Advanced	103	Removing a Tool	143

Reordering Tools	143	and Line	
Range Measurement	144	Perpendicular Line from Point to Plane ..	219
Position	145	Projected Point on Plane	219
Measurements and Settings	145	Projected Line on Plane	220
Thickness	146	Circle from Points	220
Measurements and Settings	146	Plane from Point and Normal	220
Script	148	Plane from Three Points	220
Profile Measurement	149	Line from Two Planes	220
Area	150	Point from Three Planes	221
Measurements, Features, and Settings ..	151	Point from Line and Circle	222
Bounding Box	154	Point or Line	222
Measurements, Features, and Settings ..	155	Dimension	224
Circle	157	Intersect	226
Measurements, Features, and Settings ..	157	Robot Pose	228
Circle Radii	160	Scripts	228
Measurements, Features, and Settings ..	161	Built-in Script Functions	228
Closed Area	164	Output	234
Measurements and Settings	164	Output Page Overview	234
Dimension	168	Ethernet Output	235
Measurements and Settings	168	Digital Output	239
Edge	171	Analog Output	242
Measurements, Features, and Settings ..	172	Serial Output	244
Groove	176	Dashboard	247
Measurements, Features, and Settings ..	177	Dashboard Page Overview	247
Intersect	181	State and Health Information	247
Measurements, Features, and Settings ..	181	Statistics	248
Line	184	Measurements	249
Measurements, Features, and Settings ..	185	Performance	249
Line Advanced	188	Gocator Emulator	251
Measurements, Features, and Settings ..	189	System Requirements	251
Panel	194	Limitations	252
Position	198	Downloading a Support File	252
Measurements, Features, and Settings ..	198	Running the Emulator	253
Round Corner	200	Adding a Scenario to the Emulator	254
Strip	204	Running a Scenario	255
Template Matching	209	Removing a Scenario from the Emulator	255
Measurements, Features, and Settings ..	210	Using Replay Protection	256
Script	214	Stopping and Restarting the Emulator	256
Feature Measurement	215	Running the Emulator in Default Browser	257
Create	216	Working with Jobs and Data	257
Line from Two Points	217	Creating, Saving, and Loading Jobs	257
Perpendicular or Parallel Line from Point	218	Playback and Measurement Simulation	258

Downloading, Uploading, and Exporting	
Replay Data	259
Downloading and Uploading Jobs	262
Scan, Model, and Measurement Settings	263
Calculating Potential Maximum Frame Rate ..	264
Protocol Output	264
Remote Operation	264
Gocator Accelerator	266
System Requirements and Recommendations ..	267
Benefits	267
Installation	268
Gocator Accelerator Utility	268
Dashboard and Health Indicators	270
SDK Application Integration	271
Sensor Device Files	272
Live Files	272
Log File	272
Job File Structure	273
Job File Components	273
Accessing Files and Components	274
Configuration	274
Setup	275
BackgroundSuppression	276
Filters	276
XSmoothing	276
YSmoothing	277
XGapFilling	277
YGapFilling	277
XMedian	277
YMedian	278
XDecimation	278
YDecimation	278
XSlope	278
YSlope	279
Trigger	279
Layout	281
Alignment	282
Disk	283
Bar	283
Plate	283
Polygon	283
Polygon/Corner	284

Devices / Device	284
SurfaceGeneration	291
FixedLength	292
VariableLength	292
Rotational	292
SurfaceSections	292
ProfileGeneration	293
FixedLength	293
VariableLength	294
Rotational	294
PartDetection	294
EdgeFiltering	296
PartMatching	296
Edge	296
BoundingBox	297
Ellipse	297
Replay	298
RecordingFiltering	298
Conditions/AnyMeasurement	298
Conditions/AnyData	299
Conditions/Measurement	299
Streams/Stream (Read-only)	299
ToolOptions	300
MeasurementOptions	301
FeatureOptions	301
StreamOptions	302
Tools	302
Profile Types	302
ProfileFeature	302
ProfileLine	303
ProfileRegion2d	303
Geometric Feature Types	303
Parameter Types	303
RangePosition	305
RangeThickness	306
ProfileArea	308
ProfileBoundingBox	309
ProfileCircle	311
ProfileDimension	313
ProfileGroove	314
ProfileIntersect	317
ProfileLine	318

ProfilePanel	320	List Files	357
ProfilePosition	323	Copy File	358
ProfileRoundCorner	324	Read File	358
ProfileStrip	326	Write File	359
Script	328	Delete File	359
Tool (type FeatureDimension)	329	User Storage Used	360
Tool (type FeatureIntersect)	331	User Storage Free	360
Custom	332	Get Default Job	360
Output	333	Set Default Job	361
Ethernet	333	Get Loaded Job	361
Ascii	336	Get Alignment Reference	362
EIP	336	Set Alignment Reference	362
Modbus	337	Clear Alignment	363
Profinet	337	Get Timestamp	363
Digital0 and Digital1	337	Get Encoder	363
Analog	338	Reset Encoder	364
Serial	339	Start	364
Selcom	339	Scheduled Start	365
Ascii	339	Stop	365
Transform	340	Get Auto Start Enabled	365
Device	341	Set Auto Start Enabled	366
Integrations	342	Get Voltage Settings	366
Protocols	342	Set Voltage Settings	367
Gocator Protocol	342	Get Quick Edit Enabled	367
Data Types	343	Set Quick Edit Enabled	367
Commands	344	Start Alignment	368
Discovery Commands	344	Start Exposure Auto-set	368
Get Address	345	Software Trigger	369
Set Address	345	Schedule Digital Output	369
Get Info	346	Schedule Analog Output	370
Control Commands	347	Ping	370
Protocol Version	348	Reset	371
Get Address	348	Backup	371
Set Address	349	Restore	372
Get System Info V2	349	Restore Factory	372
Get System Info	352	Get Recording Enabled	373
Get States	353	Set Recording Enabled	373
Log In/Out	355	Clear Replay Data	373
Change Password	355	Get Playback Source	374
Assign Buddies	356	Set Playback Source	374
Remove Buddies	356	Simulate	375
Set Buddy	357	Seek Playback	375

Step Playback	375	Health Results	396
Playback Position	376	Modbus Protocol	402
Clear Measurement Stats	376	Concepts	402
Read Live Log	377	Messages	402
Clear Log	377	Registers	403
Simulate Unaligned	377	Control Registers	404
Acquire	378	Output Registers	405
Acquire Unaligned	378	State	405
Create Model	379	Stamp	406
Detect Edges	379	Measurement Registers	407
Add Tool	379	EtherNet/IP Protocol	409
Add Measurement	380	Explicit Messaging	409
Read File (Progressive)	380	Identity Object (Class 0x01)	410
Export CSV (Progressive)	381	TCP/IP Object (Class 0xF5)	410
Export Bitmap (Progressive)	382	Ethernet Link Object (Class 0xF6)	411
Get Flag	383	Assembly Object (Class 0x04)	411
Set Flag	383	Command Assembly	411
Get Runtime Variable Count	384	Runtime Variable Configuration	
Set Runtime Variables	384	Assembly	412
Get Runtime Variables	384	Sensor State Assembly	413
Upgrade Commands	385	Sample State Assembly	414
Start Upgrade	385	Implicit Messaging	416
Start Upgrade Extended	386	Assembly Object (Class 0x04)	416
Get Upgrade Status	386	Implicit Messaging Command	
Get Upgrade Log	387	Assembly	416
Results	387	Implicit Messaging Output Assembly	417
Data Results	387	Rockwell Allen-Bradley Instructions	419
Stamp	388	Software and Hardware Setup	419
Video	388	Byte Order Options	419
Range	389	Setting Up Implicit Messaging on the	
Range Intensity	390	Gocator	420
Profile Point Cloud	391	Setting Up Implicit Messaging on the	
Profile Intensity	391	PLC	422
Measurement	392	Install EDS File	422
Alignment Result	393	Add Gocator IO Device to PLC Program	427
Exposure Calibration Result	393	Using the Implicit Messaging Gocator	
Event	394	Command Assembly	439
Feature Point	394	Starting a Sensor	440
Feature Line	394	Loading a Sensor Job File	443
Feature Plane	395	Setting Up Explicit Messaging on the	
Feature Circle	395	Gocator	445
Generic Message	395	Reading Single Attribute on the PLC	
		(Explicit Messaging)	445

Setting Single Attribute to Gocator on the PLC (Explicit Messaging)	452	GoSystem	482
Loading a Sensor Job File	464	GoSensor	482
ASCII Protocol	467	GoSetup	482
Connection Settings	467	GoLayout	482
Ethernet Communication	467	GoTools	483
Serial Communication	468	GoTransform	483
Polling Operation Commands (Ethernet Only)	468	GoOutput	483
Command and Reply Format	469	Data Types	483
Special Characters	469	Value Types	483
Command Channel	469	Output Types	483
Start	469	GoDataSet Type	484
Stop	470	Measurement Values and Decisions	485
Trigger	470	Batching	485
LoadJob	471	Operation Workflow	486
Stamp	471	Initialize GoSdk API Object	487
Clear Alignment	471	Discover Sensors	487
Moving Alignment	472	Connect Sensors	487
Stationary Alignment	472	Configure Sensors	487
Set Runtime Variables	473	Enable Data Channels	488
Get Runtime Variables	473	Perform Operations	488
Data Channel	473	Limiting Flash Memory Write Operations	489
Result	473	GDK	491
Value	474	Benefits	491
Decision	475	Supported Sensors	491
Health Channel	475	Typical Workflow	492
Health	476	Installation and Class Reference	492
Standard Result Format	476	Required Tools	492
Custom Result Format	477	Getting Started with the Example Code	492
Selcom Protocol	478	Building the Sample Code	493
Serial Communication	478	Tool Registration	493
Connection Settings	478	Tool Definitions	494
Message Format	478	Entry Functions	494
Development Kits	480	Parameter Configurations	495
GoSDK	480	Graphics Visualization	496
Setup and Locations	481	Debugging Your Tools	498
Class Reference	481	Debugging Entry Functions	499
Examples	481	Tips	499
Example Project Environment Variable	481	Backward Compatibility with Older Versions of Tools	499
Header Files	481	Define new parameters as optional	499
Functional Hierarchy of Classes	481	Configuration Versioning	499
		Version	501

Common Programming Operations	501
Input Data Objects	501
Setup and Region Info during Tool Initialization	502
Computing Region Based on the Offset from an Anchor Source	502
Part Matching	502
Accessing Sensor Local Storage	502
Print Output	503
Tools	504
Sensor Discovery Tool	504
CSV Converter Tool	505
CSV File Format	506
Info	507
DeviceInfo	508
RecordingFilter	508
Ranges	509
Profile	510
RawProfile	511
Troubleshooting	512
Specifications	513
Sensors	513
Gocator 1300 Series	513
Gocator 1320 (Side Mount Package)	515
Gocator 1320 (Top Mount Package)	516
Gocator 1340 (Side Mount Package)	517
Gocator 1350 (Side Mount Package)	520
Gocator 1350 (Top Mount Package)	523
Gocator 1365 (Side Mount Package)	526
Gocator 1370 (Side Mount Package)	529
Gocator 1380 (Side Mount Package)	532
Gocator 1390 (Side Mount Package)	535
Sensor Connectors	538
Gocator Power/LAN Connector	538
Grounding Shield	539
Power	539
Laser Safety Input	539
Gocator I/O Connector	540
Grounding Shield	541
Digital Outputs	542
Inverting Outputs	542
Digital Input	542

Encoder Input	543
Serial Output	544
Selcom Serial Output	544
Analog Output	545
Master Network Controllers	546
Master 100	546
Master 100 Dimensions	547
Master 400/800	548
Master 400/800 Electrical Specifications	549
Master 400/800 Dimensions	551
Master 810/2410	552
Electrical Specifications	555
Encoder	556
Input	557
Master 810 Dimensions	559
Master 2410 Dimensions	560
Master 1200/2400	561
Master 1200/2400 Electrical Specifications	562
Master 1200/2400 Dimensions	563
Accessories	564
Return Policy	567
Software Licenses	568
Support	573
Contact	574

Introduction

This documentation describes how to connect, configure, and use a Gocator. It also contains reference information on the device's protocols and job files, as well as an overview of the development kits you can use with Gocator. Finally, the documentation describes the Gocator emulator and accelerator applications.

The documentation applies to the following:

- Gocator 1300 series

Notational Conventions

This documentation uses the following notational conventions:



Follow these safety guidelines to avoid potential injury or property damage.



Consider this information in order to make best use of the product.

Gocator Overview

Safety and Maintenance

The following sections describe the safe use and maintenance of Gocator sensors.

Laser Safety

Gocator sensors contain semiconductor lasers that emit visible or invisible light and are designated as Class 2, 2M, Class 3R, or Class 3B, depending on the laser option. For more information on the laser classes used in these sensors, *Laser Classes* on the next page.

Gocator sensors are referred to as *components*, indicating that they are sold only to qualified customers for incorporation into their own equipment. These sensors do not incorporate safety items that the customer may be required to provide in their own equipment (e.g., remote interlocks, key control; refer to the references below for detailed information). As such, these sensors do not fully comply with the standards relating to laser products specified in IEC 60825-1 and FDA CFR Title 21 Part 1040.

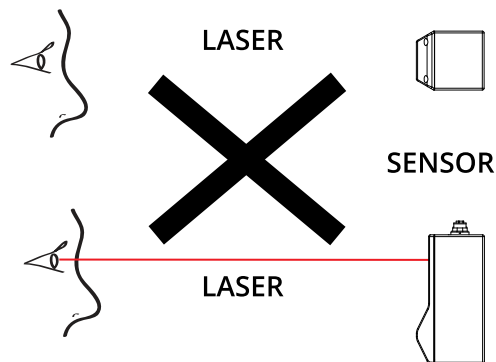

WARNING: DO NOT LOOK DIRECTLY INTO THE LASER BEAM

 Use of controls or adjustments or performance of procedures other than those specified herein may result in hazardous radiation exposure.

References

1. *International standard IEC 60825-1 (2001-08) consolidated edition*, Safety of laser products – Part 1: Equipment classification, requirements and user's guide.
2. *Technical report 60825-10*, Safety of laser products – Part 10. Application guidelines and explanatory notes to IEC 60825-1.
3. *Laser Notice No. 50*, FDA and CDRH (<https://www.fda.gov/Radiation-EmittingProducts/ElectronicProductRadiationControlProgram/default.htm>)

Laser Classes

Class 2 laser components

Class 2 laser components are considered to be safe, provided that:

- The user's blink reflex can terminate exposure (in under 0.25 seconds).
- Users do not need to look repeatedly at the beam or reflected light.
- Exposure is only accidental.

Class 2M laser components

Class 2M laser components should not cause permanent damage to the eye under reasonably foreseeable conditions of operation, provided that:

- No optical aids are used (these could focus the beam).
- The user's blink reflex can terminate exposure (in under 0.25 seconds).
- Users do not need to look repeatedly at the beam or reflected light.
- Exposure is only accidental.

Class 3R laser components

Class 3R laser products emit radiation where direct intrabeam viewing is potentially hazardous, but the risk is lower with 3R lasers than for 3B lasers. Fewer manufacturing requirements and control measures for 3R laser users apply than for 3B lasers.

- Eye protection and protective clothing are not required.
- The laser beam must be terminated at the end of an appropriate path.
- Avoid unintentional reflections.
- Personnel must be trained in working with laser equipment.

Class 3B laser components

Class 3B components are unsafe for eye exposure.

- Usually only eye protection is required. Protective gloves may also be used.
- Diffuse reflections are safe if viewed for less than 10 seconds at a minimum distance of 13 cm.
- There is a risk of fire if the beam encounters flammable materials.
- The laser area must be clearly identified.
- Use a key switch or other mechanism to prevent unauthorized use.
- Use a clearly visible indicator to show that a laser is in use, such as "Laser in operation."
- Restrict the laser beam to the working area.
- Ensure that there are no reflective surfaces in the working area.

For more information, see *Precautions and Responsibilities* on the next page.

Precautions and Responsibilities

Precautions specified in IEC 60825-1 and FDA CFR Title 21 Part 1040 are as follows:

Requirement	Class 2	Class 2M	Class 3R	Class 3B
Remote interlock	Not required	Not required	Not required	Required*
Key control	Not required	Not required	Not required	Required – cannot remove key when in use*
Power-on delays	Not required	Not required	Not required	Required*
Beam attenuator	Not required	Not required	Not required	Required*
Emission indicator	Not required	Not required	Not required	Required*
Warning signs	Not required	Not required	Not required	Required*
Beam path	Not required	Not required	Terminate beam at useful length	Terminate beam at useful length
Specular reflection	Not required	Not required	Prevent unintentional reflections	Prevent unintentional reflections
Eye protection	Not required	Not required	Not required	Required under special conditions
Laser safety officer	Not required	Not required	Not required	Required
Training	Not required	Not required	Required for operator and maintenance personnel	Required for operator and maintenance personnel

**LMI Class 3B laser components do not incorporate these laser safety items. These items must be added and completed by customers in their system design. For more information, see Class 3B Responsibilities below.*

Class 3B Responsibilities

LMI Technologies has filed reports with the FDA to assist customers in achieving certification of laser products. These reports can be referenced by an accession number, provided upon request. Detailed descriptions of the safety items that must be added to the system design are listed below.

Remote Interlock

A remote interlock connection must be present in Class 3B laser systems. This permits remote switches to be attached in serial with the keylock switch on the controls. The deactivation of any remote switches must prevent power from being supplied to any lasers.

Key Control

A key operated master control to the lasers is required that prevents any power from being supplied to the lasers while in the OFF position. The key can be removed in the OFF position but the switch must not allow the key to be removed from the lock while in the ON position.

Power-On Delays

A delay circuit is required that illuminates warning indicators for a short period of time before supplying power to the lasers.

Beam Attenuators

A permanently attached method of preventing human access to laser radiation other than switches, power connectors or key control must be employed.

Emission Indicator

It is required that the controls that operate the sensors incorporate a visible or audible indicator when power is applied and the lasers are operating. If the distance between the sensor and controls is more than 2 meters, or mounting of sensors intervenes with observation of these indicators, then a second power-on indicator should be mounted at some readily-observable position. When mounting the warning indicators, it is important not to mount them in a location that would require human exposure to the laser emissions. User must ensure that the emission indicator, if supplied by OEM, is visible when viewed through protective eyewear.

Warning Signs

Laser warning signs must be located in the vicinity of the sensor such that they will be readily observed.

Examples of laser warning signs are as follows:



FDA warning sign example

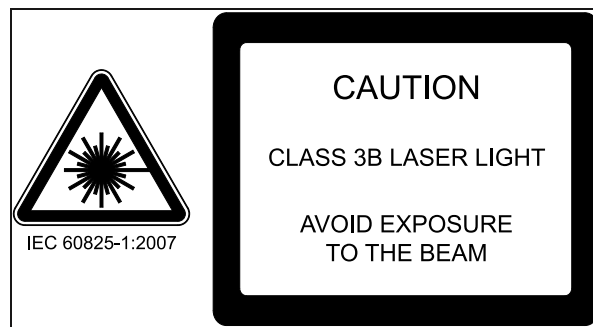

IEC warning sign example

Nominal Ocular Hazard Distance (NOHD)

In displacement sensors, the collimated light does not dissipate significantly over distance, so they retain the same laser class over this distance. For this reason, no NOHD is applicable.

Systems Sold or Used in the USA

Systems that incorporate laser components or laser products manufactured by LMI Technologies require certification by the FDA.

Customers are responsible for achieving and maintaining this certification.

Customers are advised to obtain the information booklet *Regulations for the Administration and Enforcement of the Radiation Control for Health and Safety Act of 1968: HHS Publication FDA 88-8035*.

This publication, containing the full details of laser safety requirements, can be obtained directly from the FDA, or downloaded from their web site at <https://www.fda.gov/Radiation-EmittingProducts/ElectronicProductRadiationControlProgram/default.htm>.

Electrical Safety



Failure to follow the guidelines described in this section may result in electrical shock or equipment damage.

Sensors should be connected to earth ground

All sensors should be connected to earth ground through their housing. All sensors should be mounted on an earth grounded frame using electrically conductive hardware to ensure the housing of the sensor is connected to earth ground. Use a multi-meter to check the continuity between the sensor connector and earth ground to ensure a proper connection.

Minimize voltage potential between system ground and sensor ground

Care should be taken to minimize the voltage potential between system ground (ground reference for I/O signals) and sensor ground. This voltage potential can be determined by measuring the voltage between Analog_out- and system ground. The maximum permissible voltage potential is 12 V but should be kept below 10 V to avoid damage to the serial and encoder connections.

For a description of the connector pins, see *Gocator I/O Connector* on page 540.

Use a suitable power supply

The +24 to +48 VDC power supply used with sensors should be an isolated supply with inrush current protection or be able to handle a high capacitive load.

Use care when handling powered devices

Wires connecting to the sensor should not be handled while the sensor is powered. Doing so may cause electrical shock to the user or damage to the equipment.

Handling, Cleaning, and Maintenance



Dirty or damaged sensor windows (emitter or camera) can affect accuracy. Use caution when handling the sensor or cleaning the sensor's windows.

Keep sensor windows clean

Use dry, clean air to remove dust or other dirt particles. If dirt remains, clean the windows carefully with a soft, lint-free cloth and non-streaking glass cleaner or isopropyl alcohol. Ensure that no residue is left on the windows after cleaning.

Turn off lasers when not in use

LMI Technologies uses semiconductor lasers in Gocator sensors. To maximize the lifespan of the sensor, turn off the laser when not in use.

Avoid excessive modifications to files stored on the sensor

Sensor settings are stored in flash memory inside the sensor. Flash memory has an expected lifetime of 100,000 writes. To maximize lifetime, avoid frequent or unnecessary file save operations.

Environment and Lighting

Avoid strong ambient light sources

The imager used in this product is highly sensitive to ambient light. Do not operate this device near windows or lighting fixtures that could influence measurement or data acquisition. If the unit must be installed in an environment with high ambient light levels, a lighting shield or similar device may need to be installed to prevent light from affecting measurement.

Avoid installing sensors in hazardous environments

To ensure reliable operation and to prevent damage to sensors, avoid installing the sensor in locations

- that are humid, dusty, or poorly ventilated;
- with a high temperature, such as places exposed to direct sunlight;
- where there are flammable or corrosive gases;
- where the unit may be directly subjected to harsh vibration or impact;
- where water, oil, or chemicals may splash onto the unit;
- where static electricity is easily generated.

Ensure that ambient conditions are within specifications

Sensors are suitable for operation between 0–50° C (0–40° C for Gocator 2500 sensors) and 25–85% relative humidity (non-condensing). Measurement error due to temperature is limited to 0.015% of full scale per degree C. The storage temperature is -30–70° C.

The Master network controllers are similarly rated for operation between 0–50° C.



The sensor must be heat-sunk through the frame it is mounted to. When a sensor is properly heat sunk, the difference between ambient temperature and the temperature reported in the sensor's health channel is less than 15° C.



Sensors are high-accuracy devices, and the temperature of all of its components must therefore be in equilibrium. When the sensor is powered up, a warm-up time of at least one hour is required to reach a consistent spread of temperature in the sensor.

Getting Started

The following sections provide system and hardware overviews, in addition to installation and setup procedures.

Hardware Overview

The following sections describe Gocator and its associated hardware.

Side Mount Package

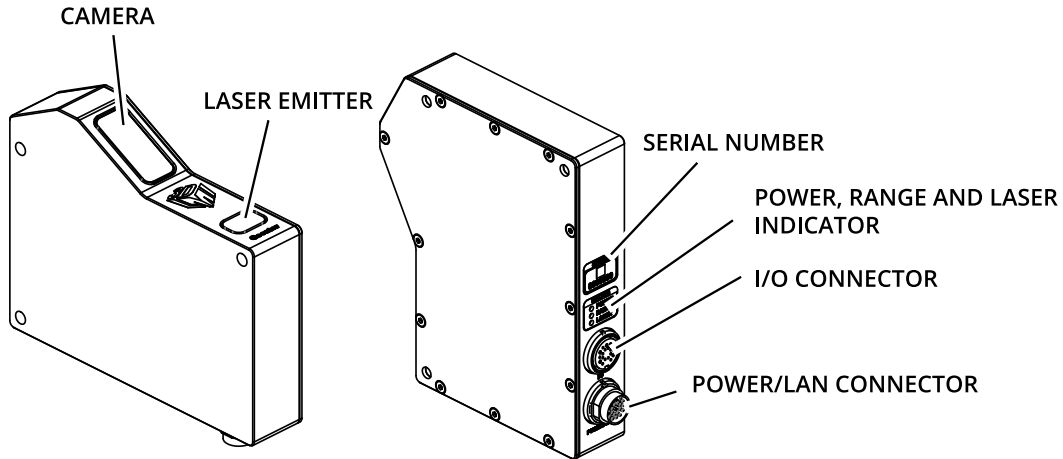

Item	Description
Camera	Observes laser light reflected from target surfaces.
Laser Emitter	Emits structured light for laser ranging.
I/O Connector	Accepts input and output signals.
Power / LAN Connector	Accepts power and laser safety signals and connects to 1000 Mbit/s Ethernet network.
Power Indicator	Illuminates when power is applied (blue).
Range Indicator	Illuminates when camera detects laser light and is within the target range (green).
Laser Indicator	Illuminates when laser safety input is active (amber).
Serial Number	Unique sensor serial number.

Top Mount Package

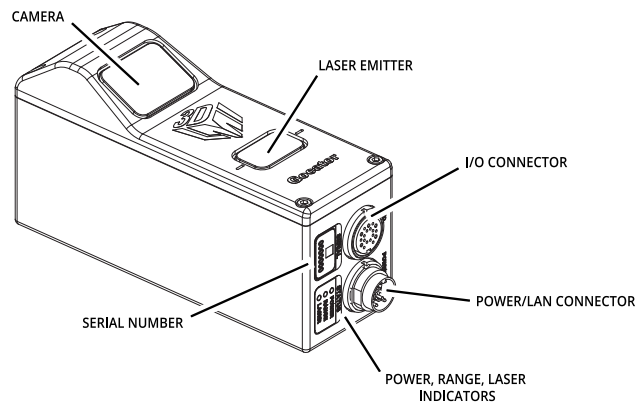

Item	Description
Camera	Observes laser light reflected from target surfaces.
Laser Emitter	Emits structured light for laser ranging.
I/O Connector	Accepts input and output signals.
Power / LAN Connector	Accepts power and laser safety signals and connects to 1000 Mbit/s Ethernet network.
Power Indicator	Illuminates when power is applied (blue).
Range Indicator	Illuminates when camera detects laser light and is within the target range (green).
Laser Indicator	Illuminates when laser safety input is active (amber).
Serial Number	Unique sensor serial number.

Gocator Cordsets

Gocator 1300 sensors use two types of cordsets.

The Power & Ethernet cordset is used for sensor communication via 1000 Mbit/s Ethernet over a standard RJ45 connector. The Master version of the Power & Ethernet cordset provides electrical connection between the sensor and a [Master network controller](#) (excluding Master 100).

The Gocator I/O cordset provides power and laser safety interlock to sensors. It also provides digital I/O connections, an encoder interface, RS-485 serial connection, and an analog output.

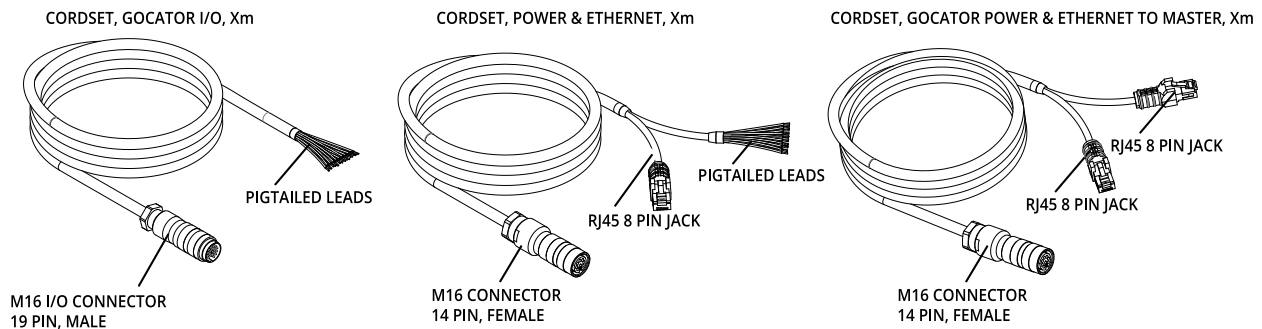

See *Accessories* on page 564 for cordset lengths and part numbers. Contact LMI for information on creating cordsets with customized lengths and connector orientations.

Master 100

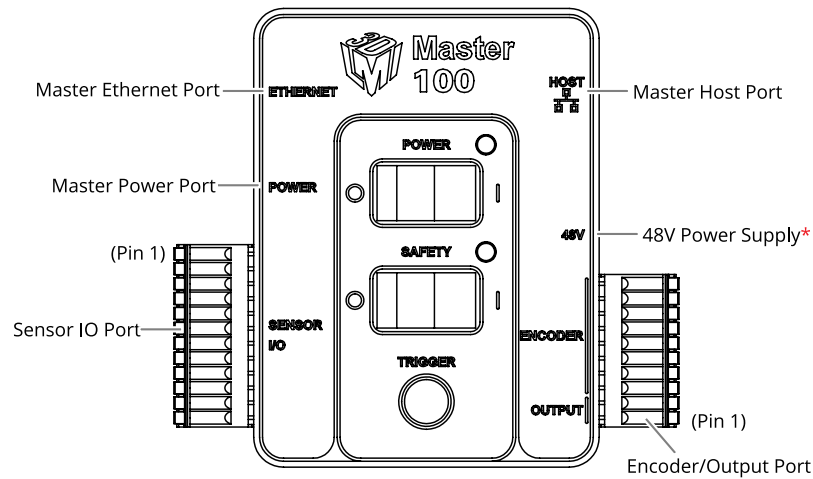

Item	Description
Master Ethernet Port	Connects to the RJ45 connector labeled Ethernet on the Power/LAN to Master cordset.
Master Power Port	Connects to the RJ45 connector labeled Power/Sync on the Power/LAN to Master cordset. Provides power and laser safety to the sensor.
Sensor I/O Port	Connects to the I/O cordset.
Master Host Port	Connects to the host PC's Ethernet port.
Power	Accepts power (+48 V).
Power Switch	Toggles sensor power.
Safety Switch	Toggles safety signal provided to the sensors [O= off, I= on]. This switch must be set to on in order to scan with laser-based sensors.
Trigger	Signals a digital input trigger to the sensor.
Encoder	Accepts encoder A, B and Z signals.
Digital Output	Provides digital output.

See *Master 100* on page 546 for pinout details.

Master 400 / 800 / 1200 / 2400

The Master 400, 800, 1200, and 2400 network controllers let you connect more than two sensors:

- Master 400: accepts four sensors
- Master 800 accepts eight sensors
- Master 1200: accepts twelve sensors
- Master 2400: accepts twenty-four sensors

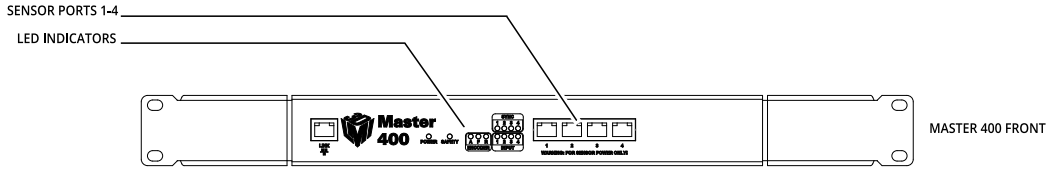

MASTER 400 FRONT

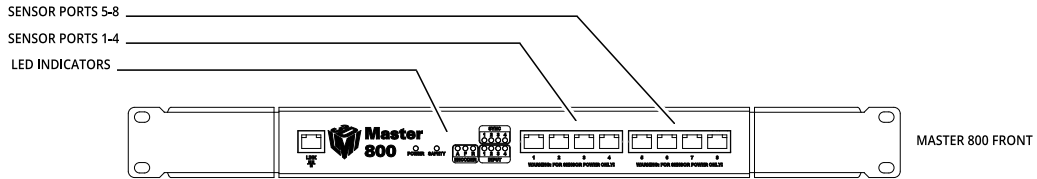

MASTER 800 FRONT

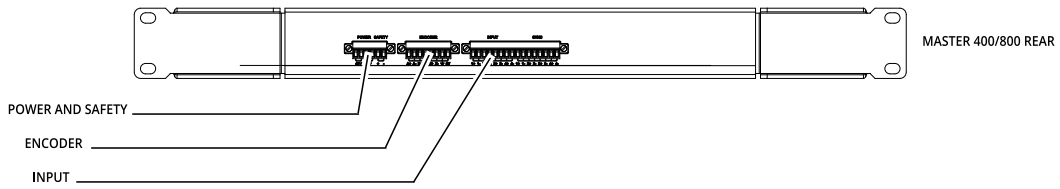

MASTER 400/800 REAR

Master 400 and 800

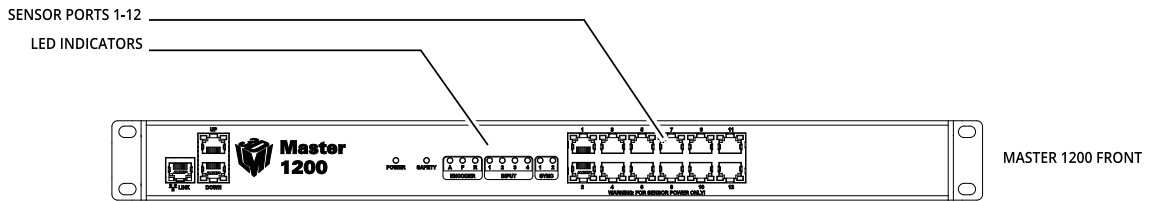

MASTER 1200 FRONT

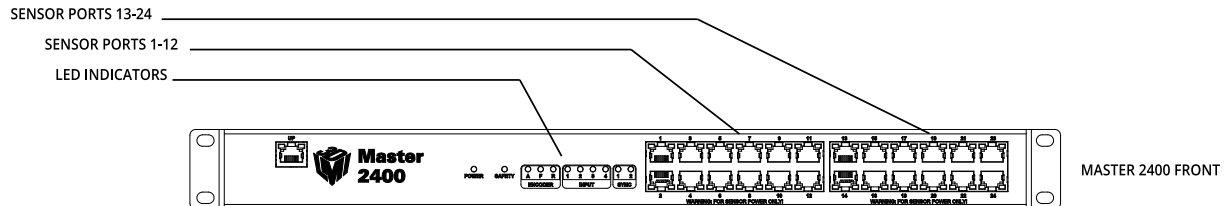

MASTER 2400 FRONT

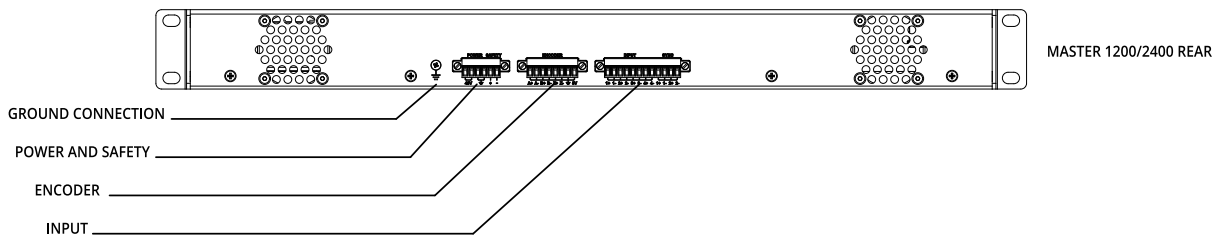

MASTER 1200/2400 REAR

Master 1200 and 2400

Item	Description
Sensor Ports	Master connection for sensors (no specific order required).

Item	Description
Ground Connection	Earth ground connection point.
Power and Safety	Power and safety connections. Safety input must be high in order to scan with laser-based sensors.
Encoder	Accepts encoder signal.
Input	Accepts digital input.

For pinout details for Master 400 or 800, see *Master 400/800* on page 548.

For pinout details for Master 1200 or 2400, see *Master 1200/2400* on page 561.

Master 810 / 2410

The Master 810 and 2410 network controllers let you connect multiple sensors to create a multi-sensor system:

- Master 810 accepts up to eight sensors
- Master 2410 accepts up to twenty-four sensors

Both models let you divide the quadrature frequency of a connected encoder to make the frequency compatible with the Master, and also set the debounce period to accommodate faster encoders. For more information, see *Configuring Master 810* on page 40. (Earlier revisions of these models lack the DIP switches.)

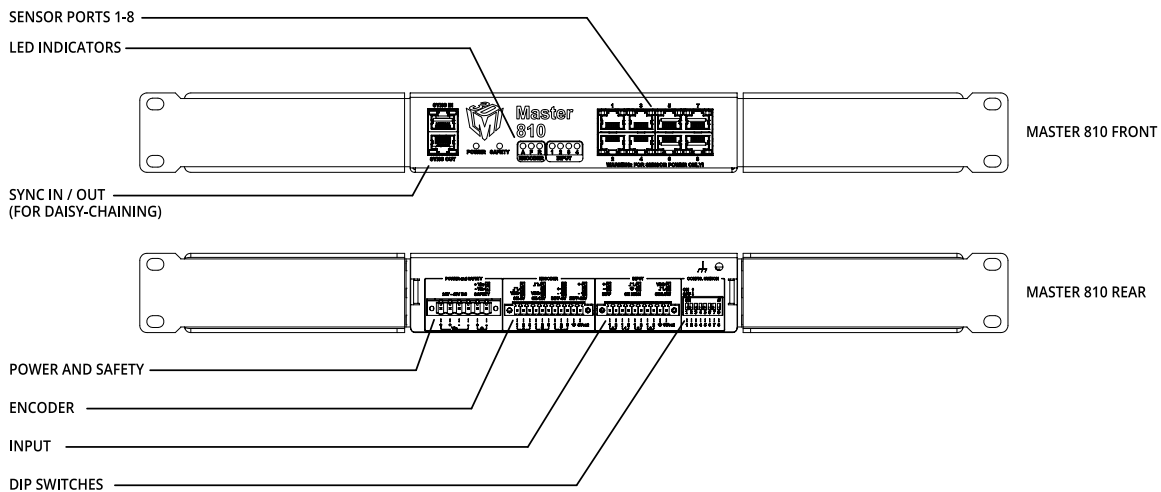

Master 810

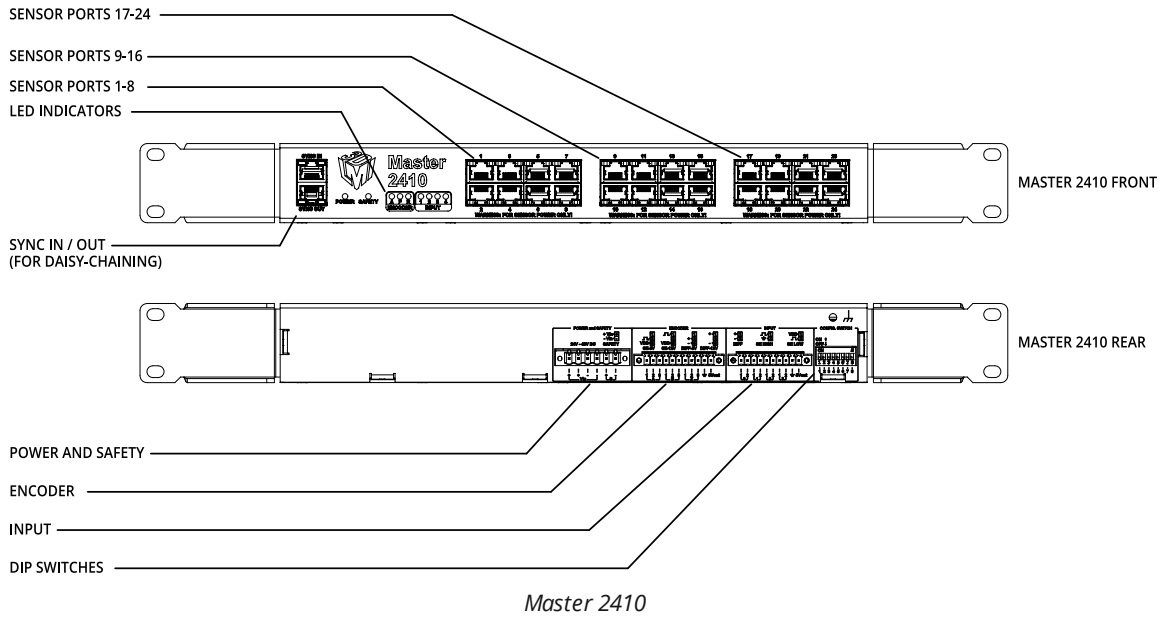

Item	Description
Sensor Ports	Master connection for sensors (no specific order required).
Power and Safety	Power and safety connections. Safety input must be high in order to scan with laser-based sensors.
Encoder	Accepts encoder signal.
Input	Accepts digital input.
DIP Switches	Configures the Master (for example, allowing the device to work with faster encoders). For information on configuring Master 810 and 2410 using the DIP switches, see <i>Configuring Master 810</i> on page 40.

For pinout details, see *Master 810/2410* on page 552.

Alignment Targets

Targets are used for aligning sensors and calibrating transport systems.

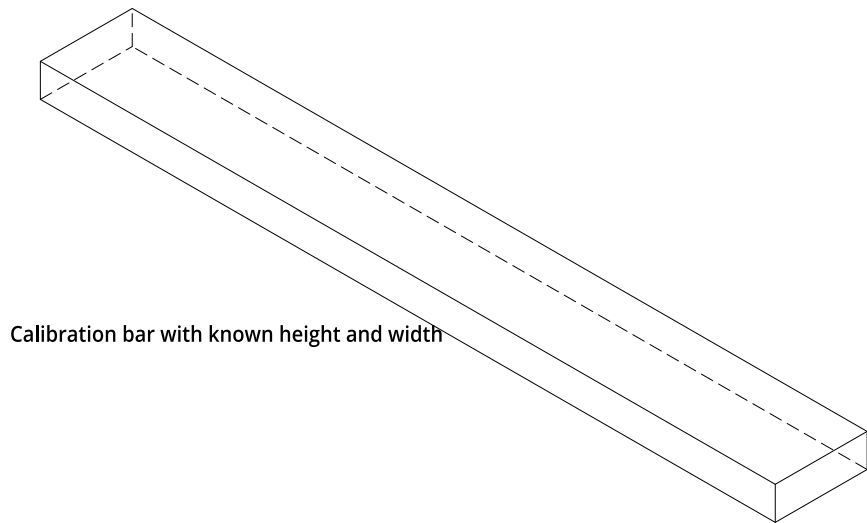

Calibration bar with known height and width

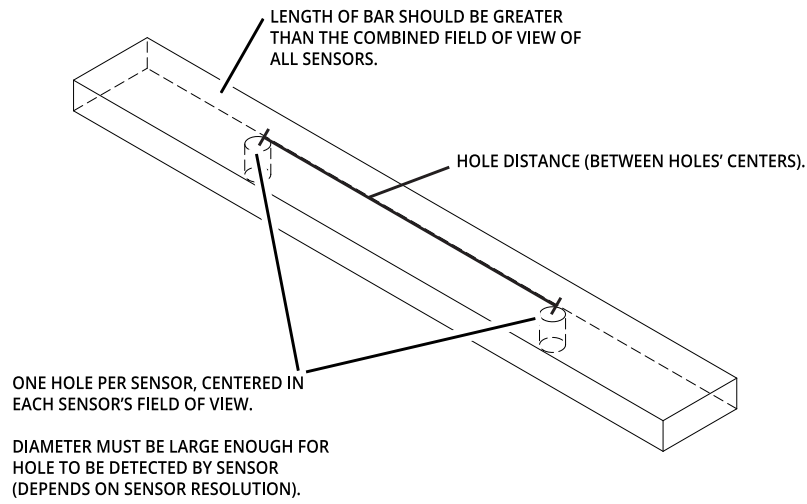

For multi-sensor systems in a ring layout, use a polygon-shaped alignment target. The number of corners in the target should correspond with the number of sensors in the system. Sensors should be positioned so that each sensor can scan a corner and surrounding surface.

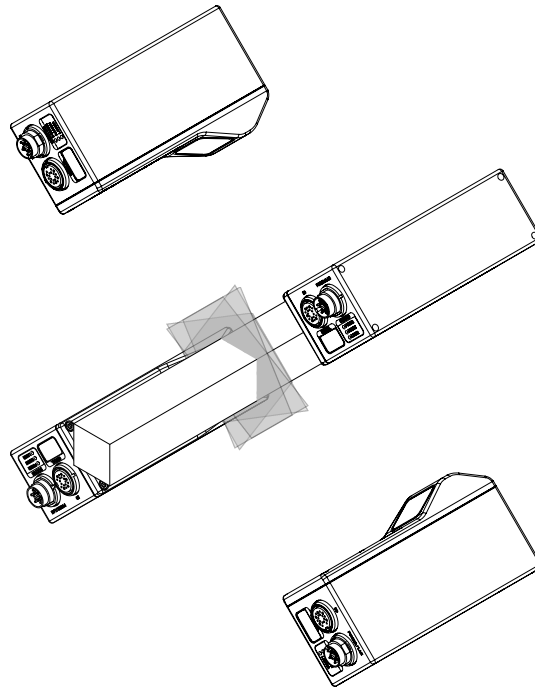

For more information on alignment, see *Aligning Sensors* on page 107.

System Overview

Gocator sensors can be installed and used in a variety of scenarios. Sensors can be connected as standalone devices, dual-sensor systems, or multi-sensor systems.

Standalone System

Standalone systems are typically used when only a single sensor is required. The device can be connected to a computer's Ethernet port for setup and can also be connected to devices such as encoders, photocells, or PLCs.

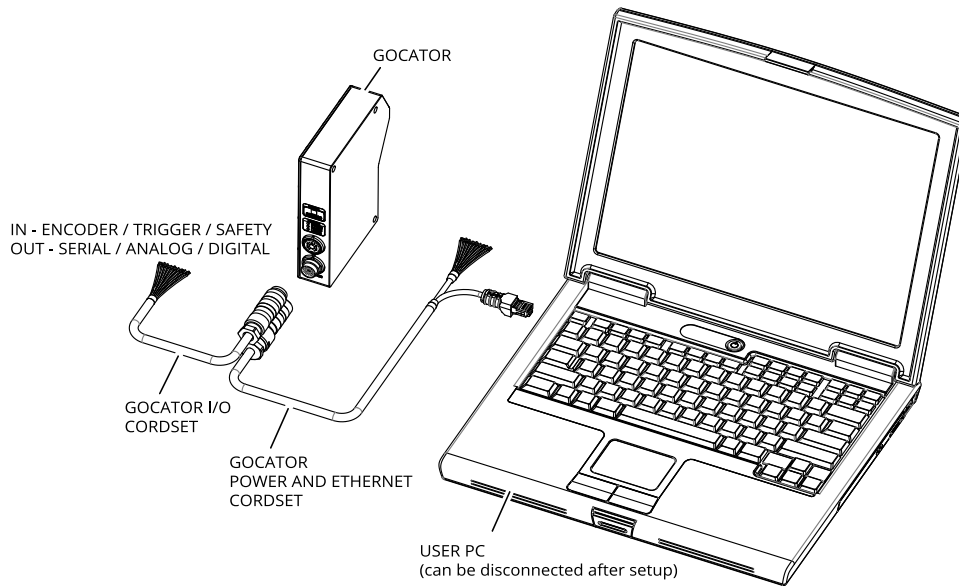

Dual-Sensor System

In a dual-sensor system, two sensors work together to perform data acquisition and output the combined results. The controlling sensor is referred to as the *Main* sensor, and the other sensor is referred to as the *Buddy* sensor. The sensor's software recognizes three installation orientations: *Opposite*, *Wide*, and *Reverse*.

A [Master network controller](#) (excluding Master 100) must be used to connect two sensors in a dual-sensor system. Gocator Master cordsets are used to connect sensors to the Master.

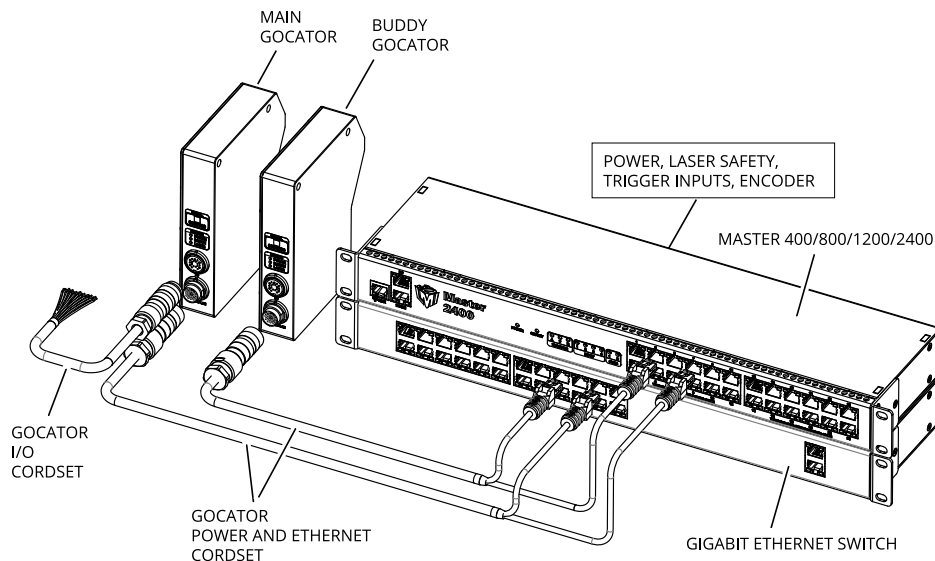

Multi-Sensor System

A [Master network controller](#) (excluding Master 100) can be used to connect two or more sensors into a multi-sensor system. Master cordsets are used to connect the sensors to a Master. The Master provides

a single point of connection for power, safety, encoder, and digital inputs. A Master 400/800/810/1200/2400/2410 can be used to ensure that the scan timing is precisely synchronized across sensors. Sensors and client computers communicate via an Ethernet switch (1 Gigabit/s recommended).

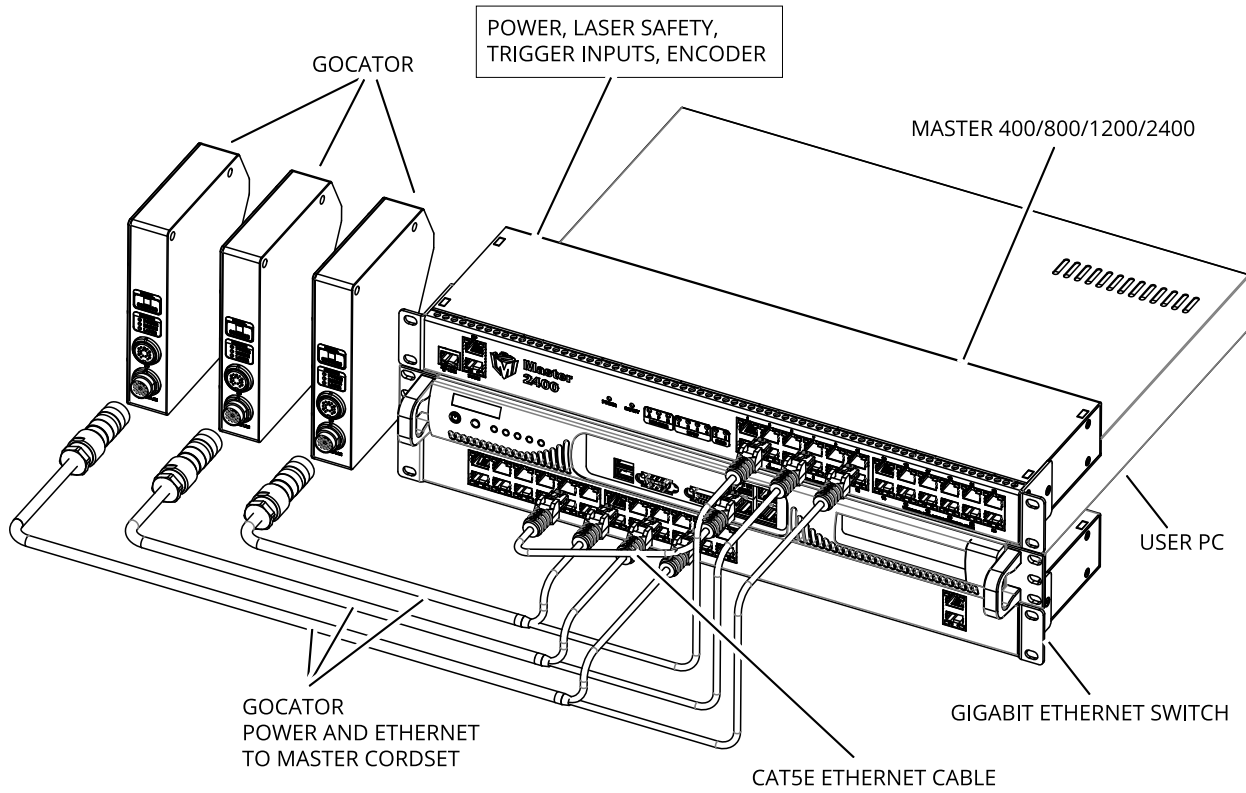

Installation

The following sections provide grounding, mounting, and orientation information.

Mounting: Side Mount Package

Single point sensors are often mounted with the triangulation base perpendicular to the travel direction to avoid occlusions.

Sensors should be mounted using M6 x 1.0 pitch screws of suitable length. The recommended thread engagement into the housing is 8-10 mm. Proper care should be taken in order to ensure that the internal threads are not damaged from cross-threading or improper insertion of screws.

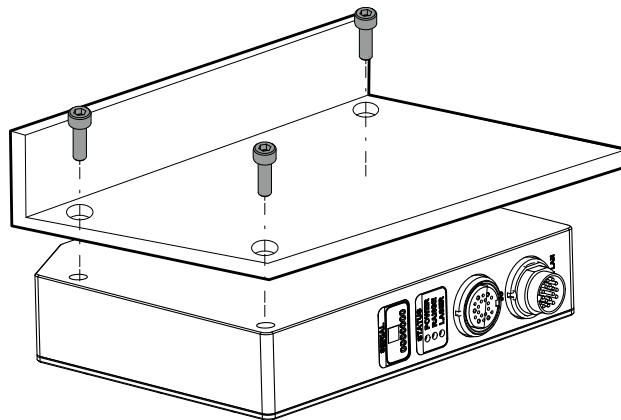

Sensors should not be installed near objects that might occlude a camera's view of the laser.

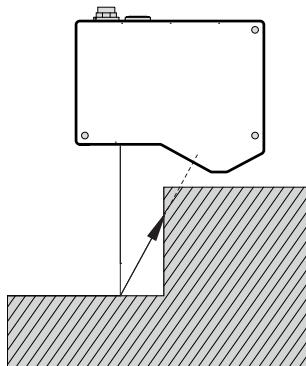

Sensors should not be installed near surfaces that might create unanticipated laser reflections.

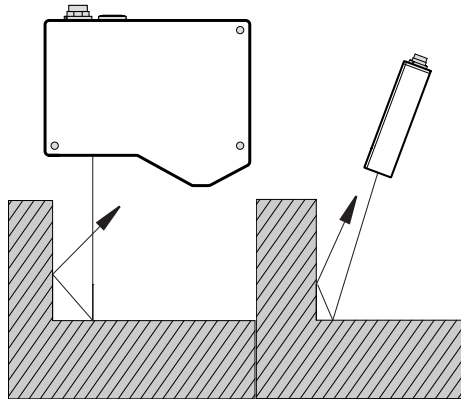

The sensor must be heat sunk through the frame it is mounted to. When a sensor is properly heat sunk, the difference between ambient temperature and the temperature reported in the sensor's health channel is less than 15° C.



Gocator sensors are high-accuracy devices. The temperature of all of its components must be in equilibrium. When the sensor is powered up, a warm-up time of at least one hour is required to reach a consistent spread of temperature within the sensor.

Mounting - Top Mount Package



Single point sensors are often mounted with the triangulation base perpendicular to the travel direction to avoid occlusions.

Sensors should be mounted using four M5 x 0.8 pitch screws of suitable length. The recommended thread engagement into the housing is 8-10 mm. Proper care should be taken in order to ensure that the internal threads are not damaged from cross-threading or improper insertion of screws.

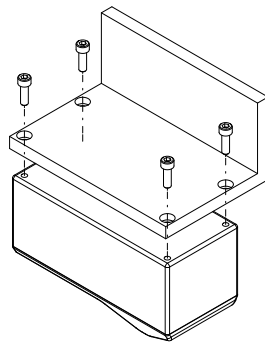

Sensors should not be installed near objects that might occlude a camera's view of the laser.

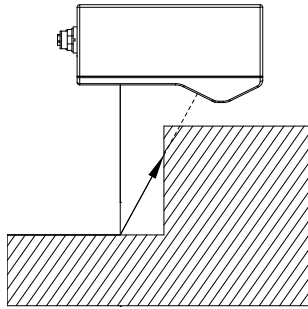

Sensors should not be installed near surfaces that might create unanticipated laser reflections.

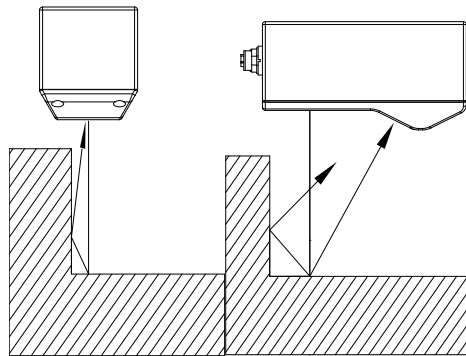

The sensor must be heat sunk through the frame it is mounted to. When a sensor is properly heat sunk, the difference between ambient temperature and the temperature reported in the sensor's health channel is less than 15° C.



Gocator sensors are high-accuracy devices. The temperature of all of its components must be in equilibrium. When the sensor is powered up, a warm-up time of at least one hour is required to reach a consistent spread of temperature within the sensor.

Orientations

The examples below illustrate the possible mounting orientations for standalone and dual-sensor systems.

See *Layout* on page 75 for more information on orientations.

Standalone Orientations

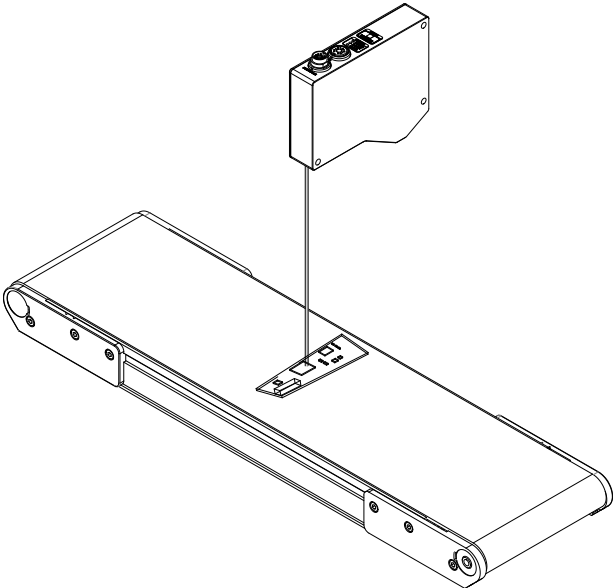

Single sensor above conveyor

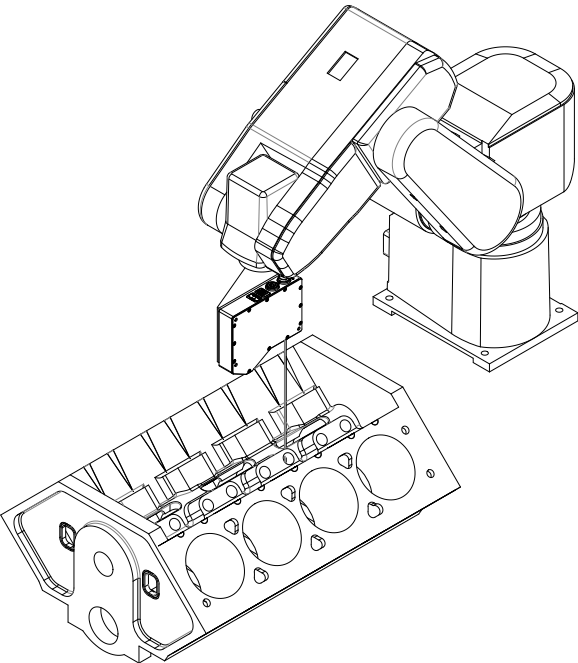

Single sensor on robot arm

Dual-Sensor System Orientations:

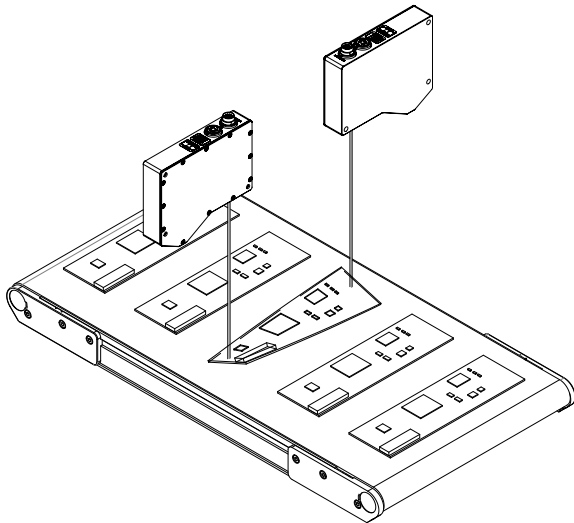

Side-by-side for wide-area measurement (Wide)

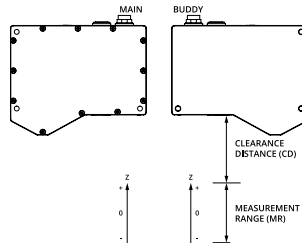

Main must be on the left side (when looking into the connector) of the Buddy (Wide)

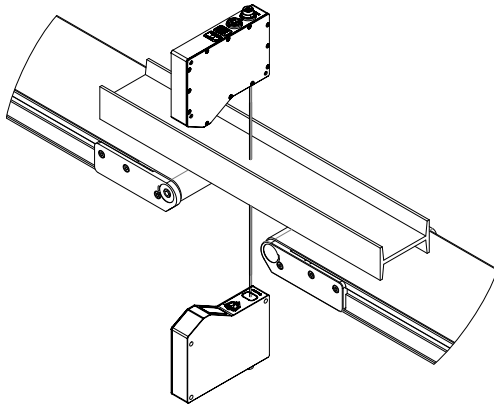

Above/below for two-sided measurement (Opposite)

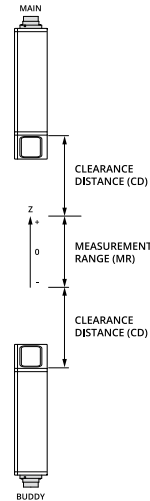

Main must be on the top with Buddy at the bottom (Opposite)

Cordset Bend Radius Limits

Limit bends in cordsets based on which type you are using (standard or high flex). The following table lists the bend limits, as well as number of bends performed in LMI's testing.



In the table below, part numbers do not include the length indicator.

Bend Radius Limits

Cable Type	Cordset	Part Numbers	Outer Diameter	Static (mm)	Dynamic (mm)	Number of Ticks (90° Tick Tock)	Number of Ticks (U-shape)
Standard	Power and Ethernet to Master	30858, 30877, 30861, 30880	8.89	45	140	> 2,000,000	
	I/O	30864, 30883	8	45	124	> 2,000,000	
High Flex	Power and Ethernet to Master	301165, 301173, 301176, 301171	8.5	34	40	> 2,000,000	> 7,000,000
	I/O	301175, 301172	9	34	40	> 2,000,000	> 7,000,000

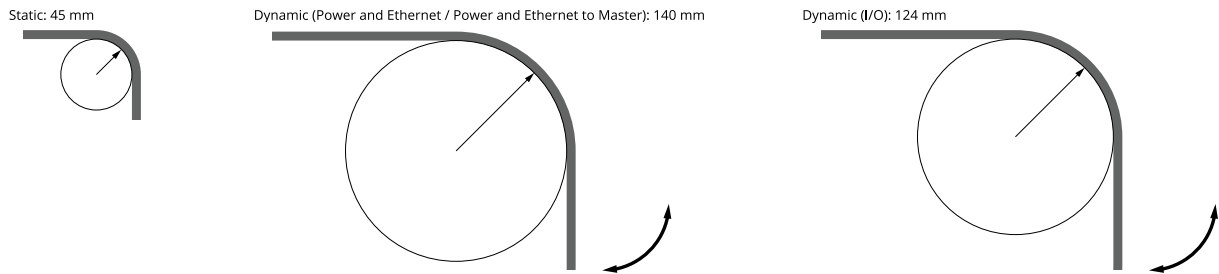

Standard cordset bend radius limits

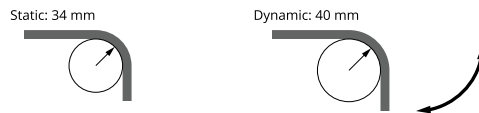

High flex cordset bend radius limits

The following illustrations show the test setups used to determine the number of bends.

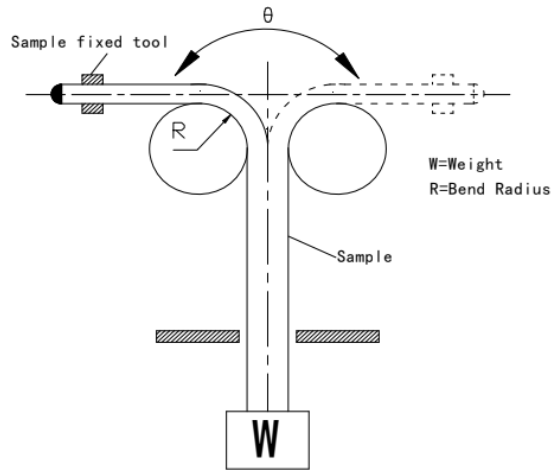

Tick-tock test setup ($\theta = 180^\circ$)

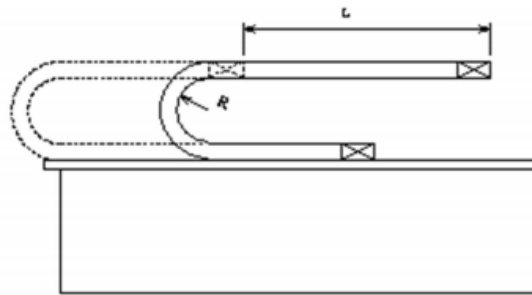

U-shape test setup ($L = 500\text{ mm}$).

For cordset part numbers, see *Accessories* on page 564.

For more information on cordsets, see *Gocator Cordsets* on page 21.

Grounding

Components of a sensor system should be properly grounded.

Gocator

Gocator sensors should be grounded to the earth/chassis through their housings and through the grounding shield of the Power I/O cordset. Sensors have been designed to provide adequate grounding through their mounting screws. Always check grounding with a multi-meter to ensure electrical continuity between the mounting frame and the sensor's connectors.

 The frame or electrical cabinet that the sensor is mounted to must be connected to earth ground.

Recommended Practices for Cordsets

If you need to minimize interference with other equipment, you can ground the Power & Ethernet or the Power & Ethernet to Master cordset (depending on which cordset you are using) by terminating the

shield of the cordset before the split. The most effective grounding method is to use a 360-degree clamp.

CORSET, POWER & ETHERNET, Xm

CORSET, GOCATOR POWER & ETHERNET TO MASTER, Xm

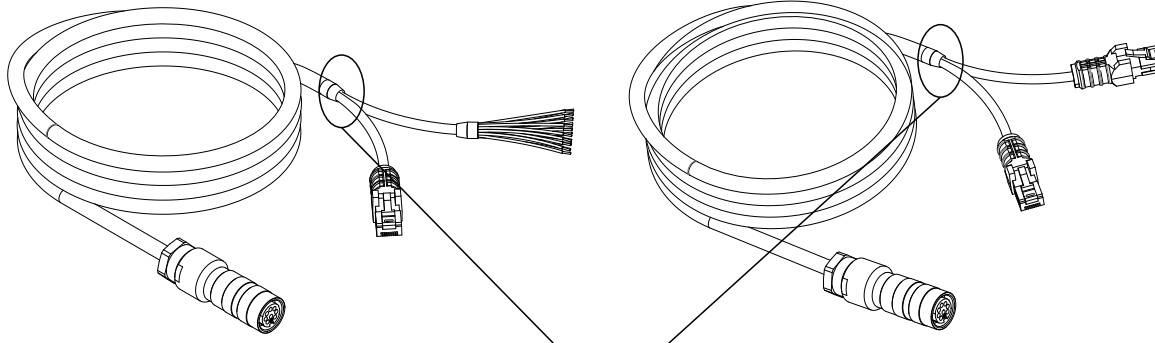

Attach the 360-degree clamp before the split

To terminate the cordset's shield:

1. Expose the cordset's braided shield by cutting the plastic jacket before the point where the cordset splits.



2. Install a 360-degree ground clamp.



Master Network Controllers

The rack mount brackets provided with all Masters are designed to provide adequate grounding through the use of star washers. Always check grounding with a multi-meter by ensuring electrical continuity between the mounting frame and RJ45 connectors on the front.



When using the rack mount brackets, you *must* connect the frame or electrical cabinet to which the Master is mounted to earth ground.



You *must* check electrical continuity between the mounting frame and RJ45 connectors on the front using a multi-meter.

If you are mounting Master 810 or 2410 using the provided DIN rail mount adapters, you must ground the Master directly; for more information, see *Grounding When Using a DIN Rail (Master 810/2410)* below.

Grounding When Using a DIN Rail (Master 810/2410)

If you are using DIN rail adapters instead of the rack mount brackets, you must ensure that the Master is properly grounded by connecting a ground cable to one of the holes indicated below. The holes accept M4x5 screws.

 You can use any of the ground holes shown below. However, LMI recommends using the holes indicated on the housing by a ground symbol.

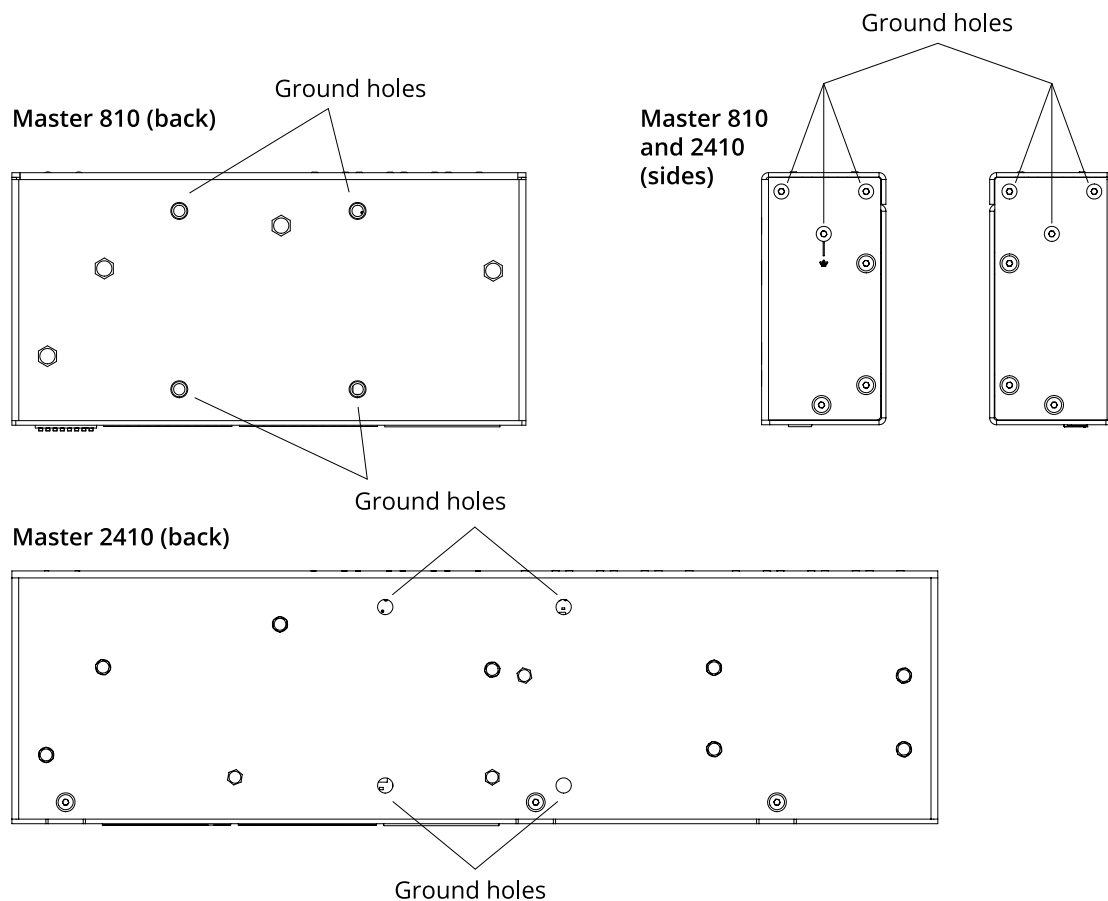

An additional ground hole is provided on the rear of Master 810 and 2410 network controllers, indicated by a ground symbol.

Additional Grounding Schemes

Potential differences and noise in a system caused by grounding issues can sometimes cause sensors to reset or otherwise behave erratically. If you experience such issues, see the *Gocator Grounding Guide* (<https://downloads.lmi3d.com/gocator-grounding-guide>) in the Download center for additional grounding schemes.

Installing DIN Rail Clips: Master 810 or 2410

You can mount the Master 810 and 2410 using the included DIN rail mounting clips with M4x8 flat socket cap screws. The following DIN rail clips ([DINM12-RC](#)) are included:



Older revisions of Master 810 and 2410 network controllers use a different configuration for the DIN rail clip holes.

To install the DIN rail clips:

1. Remove the 1U rack mount brackets.
2. Locate the DIN rail mounting holes on the back of the Master (see below).

Master 810:

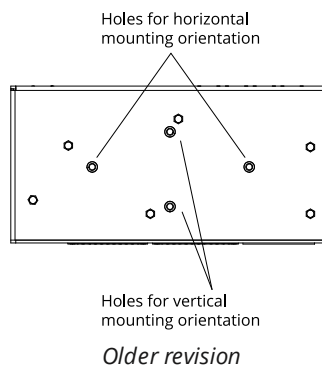
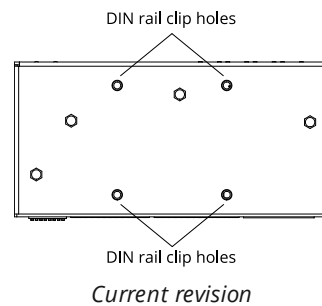

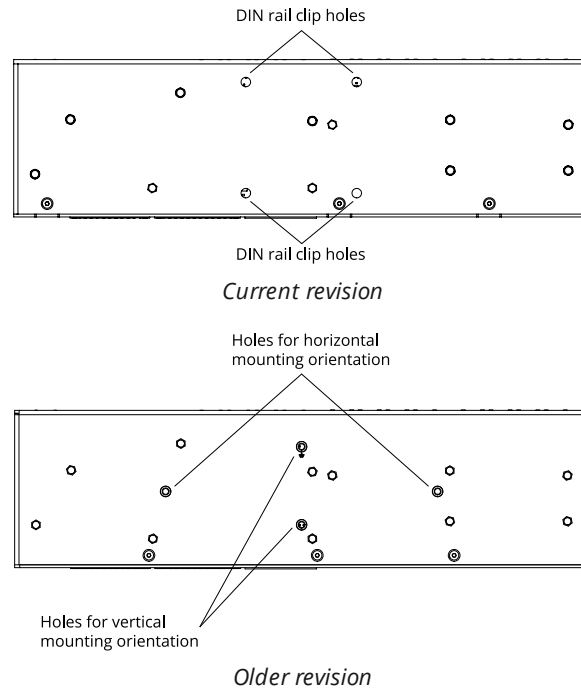

Master 2410:

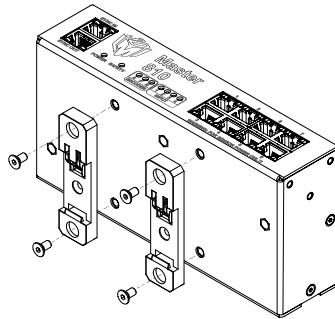

3. Attach the two DIN rail mount clips to the back of the Master using two M4x8 flat socket cap screws for each one.

The following illustration shows the installation of clips on a Master 810 (current revision) for horizontal mounting:



 Ensure that there is enough clearance around the Master for cabling.

Configuring Master 810

If you are using Master 810 with an encoder that runs at a quadrature frequency higher than 300 kHz, you must use the device's divider DIP switches to limit the incoming frequency to 300 kHz.

 Master 810 supports up to a maximum incoming encoder quadrature frequency of 6.5 MHz.

The DIP switches are located on the rear of the device.

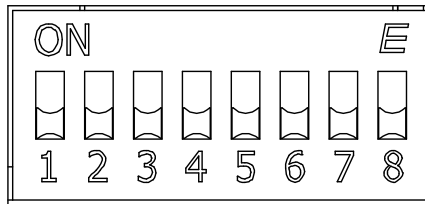

 Switches 5 to 8 are reserved for future use.

This section describes how to set the DIP switches on Master 810 to do the following:

- Set the divider so that the quadrature frequency of the connected encoder is compatible with the Master.
- Set the debounce period to accommodate faster encoders.

Setting the Divider

To set the divider, you use switches 1 to 3. To determine which divider to use, use the following formula:

$$\text{Output Quadrature Frequency} = \text{Input Quadrature Frequency} / \text{Divider}$$

In the formula, use the *quadrature frequency* of the encoder (for more information, see *Encoder Quadrature Frequency* below) and a divider from the following table so that the Output Quadrature Frequency is no more than 300 kHz.

Divider	Switch 1	Switch 2	Switch 3
1	OFF	OFF	OFF
2	ON	OFF	OFF
4	OFF	ON	OFF
8	ON	ON	OFF
16	OFF	OFF	ON
32	ON	OFF	ON
64	OFF	ON	ON
128	ON	ON	ON

 The divider works on debounced encoder signals. For more information, see *Setting the Debounce Period* on the next page.

Encoder Quadrature Frequency

Encoder quadrature frequency is defined as illustrated in the following diagram. It is the frequency of encoder ticks. This may also be referred as the native encoder rate.

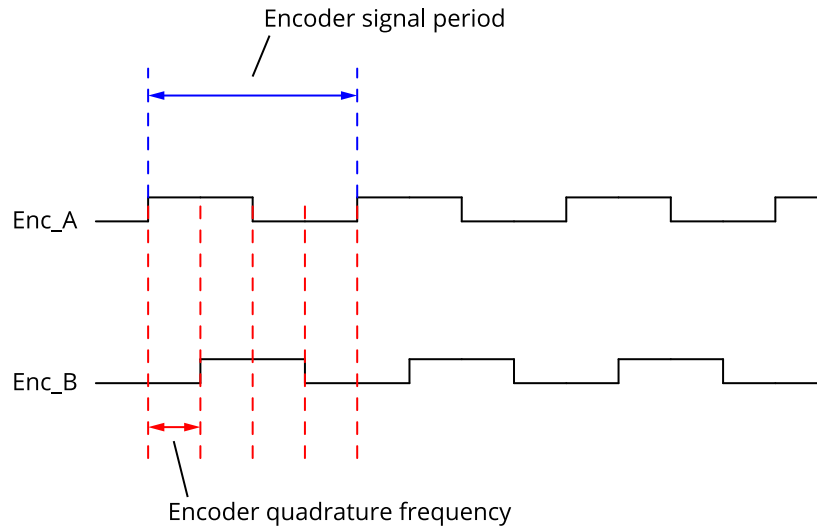

You must use a quadrature frequency when determining which divider to use (see *Setting the Divider* on the previous page). Consult the datasheet of the encoder you are using to determine its quadrature frequency.

 Some encoders may be specified in terms of encoder signal frequency (or period). In this case, convert the signal frequency to quadrature frequency by multiplying the signal frequency by 4.

Setting the Debounce Period

If the quadrature frequency of the encoder you are using is greater than 3 MHz, you must set the debounce period to “short.” Otherwise, set the debounce period to “long.”

You use switch 4 to set the debounce period.

Debounce period	Switch 4
short debounce	ON
long debounce	OFF

Network Setup

The following sections provide procedures for client PC and sensor network setup.

 DHCP is not recommended for sensors. If you choose to use DHCP, the DHCP server should try to preserve IP addresses. Ideally, you should use static IP address assignment (by MAC address) to do this.

Client Setup

To connect to a sensor from a client PC, you must ensure the client's network card is properly configured.

Sensors are shipped with the following default network configuration:

Setting	Default
DHCP	Disabled
IP Address	192.168.1.10
Subnet Mask	255.255.255.0
Gateway	0.0.0.0

 All sensors are configured to 192.168.1.10 as the default IP address. For a dual-sensor system, the Main and Buddy sensors must be assigned unique addresses before they can be used on the same network. Before proceeding, connect the Main and Buddy sensors one at a time (to avoid an address conflict) and use the steps in See *Running a Dual-Sensor System* on page 46 to assign each sensor a unique address.

To connect to a sensor for the first time:

1. Connect cables and apply power.
Sensor cabling is illustrated in *System Overview* on page 27.

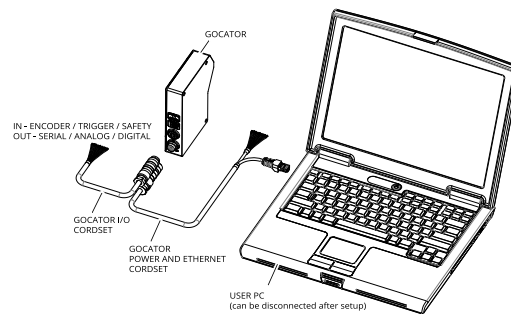

2. Change the client PC's network settings.

Windows 7

- a. Open the Control Panel, select **Network and Sharing Center**, and then click **Change Adapter Settings**.
- b. Right-click the network connection you want to modify, and then click **Properties**.
- c. On the **Networking** tab, click **Internet Protocol Version 4 (TCP/IPv4)**, and then click **Properties**.
- d. Select the **Use the following IP address** option.
- e. Enter IP Address "192.168.1.5" and Subnet Mask "255.255.255.0", then click **OK**.

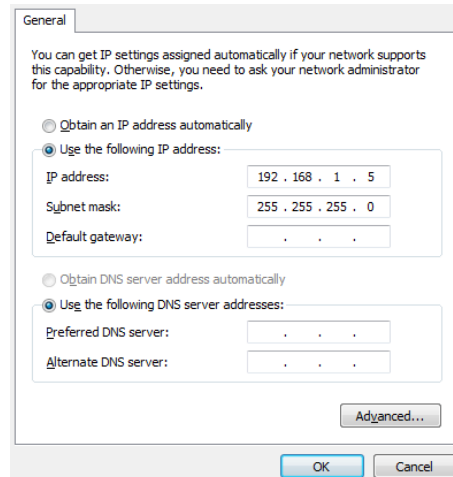

Mac OS X v10.6

- a. Open the Network pane in **System Preferences** and select **Ethernet**.
- b. Set **Configure** to **Manually**.
- c. Enter IP Address "192.168.1.5" and Subnet Mask "255.255.255.0", then click **Apply**.

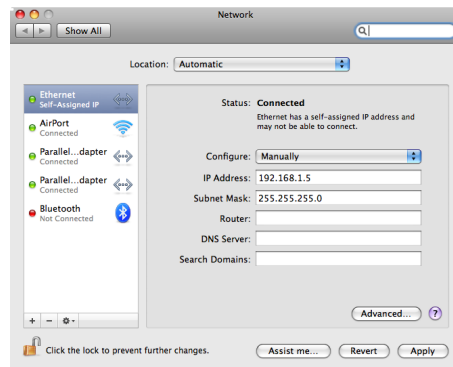

See *Troubleshooting* on page 512 if you experience any problems while attempting to establish a connection to the sensor.

Gocator Setup

The Gocator is shipped with a default configuration that will produce 3D data for most targets.

The following describes how to set up a sensor system for operations. After you have completed the setup, you can perform a scan to verify basic sensor operation.

Running a Standalone Sensor System

To configure a standalone sensor system:

1. Power up the sensor.
The power indicator (blue) should turn on immediately.

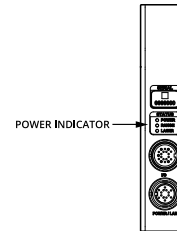

2. Enter the sensor's IP address (192.168.1.10) in a web browser.

The sensor interface loads.

If a password has been set, you will be prompted to provide it and then log in.



3. Go to the **Manage** page.

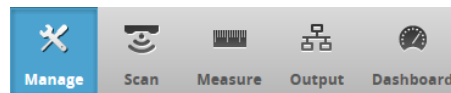

4. Ensure that Replay mode is off (the slider is set to the left).

Replay mode disables measurements.



5. Ensure that the Laser Safety Switch is enabled or the Laser Safety input is high.
6. Go to the **Scan** page.
7. Observe the profile in the data viewer
8. Press the **Start** button or the **Snapshot** on the **Toolbar** to start the sensor.

The **Start** button is used to run sensors continuously.

The **Snapshot** button is used to trigger the capture of a single frame.

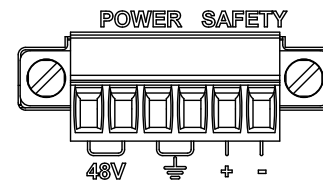

Master 400/800/1200/2400

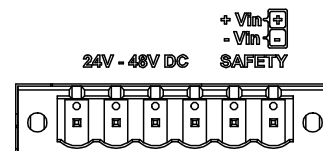

Master 810/2410

- Move a target into the sensor's projected light.
If a target object is within the sensor's measurement range, the data viewer will display scan data, and the sensor's range indicator will illuminate.
If no scan data is displayed in the data viewer, see *Troubleshooting* on page 512.

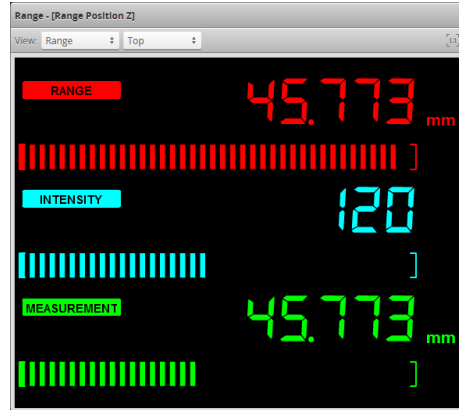

- Press the **Stop** button.
The projected light should turn off.



Running a Dual-Sensor System

All sensors are shipped with a default IP address of 192.168.1.10. Ethernet networks require a unique IP address for each device, so you must set up a unique address for each sensor.

To configure a dual-sensor system:

- Turn off the sensors and unplug the Ethernet network connection of the Main sensor.
All sensors are shipped with a default IP address of 192.168.1.10. Ethernet networks require a unique IP address for each device. Skip step 1 to 3 if the Buddy sensor's IP address is already set up with a unique address.

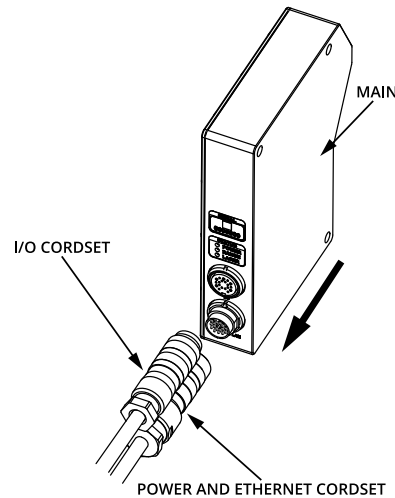

- Power up the Buddy sensor.
The power LED (blue) of the Buddy sensor should turn on immediately.

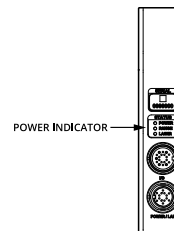

- Enter the sensor's IP address 192.168.1.10 in a web browser.
The web interface loads.



- Go to the **Manage** Page.
- Modify the IP address to 192.168.1.11 in the **Networking** category and click the **Save** button.

When you click the **Save** button, you will be prompted to confirm your selection.

- Turn off the sensors, re-connect the Main sensor's Ethernet connection and power-cycle the sensors.

After changing network configuration, the sensors must be reset or power-cycled before the change will take effect.

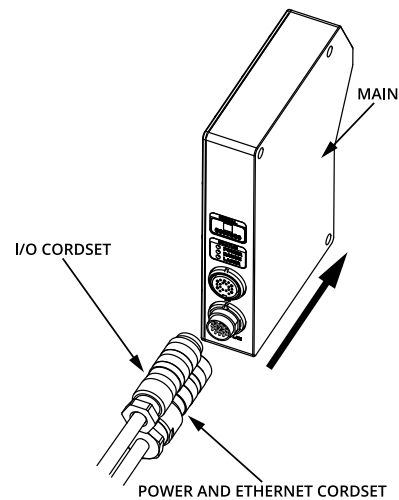
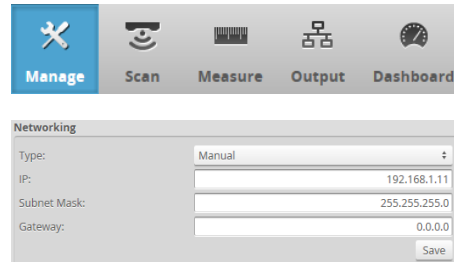

- Enter the sensor's IP address 192.168.1.10 in a web browser.
- The web interface loads.



- Select the **Manage** page.

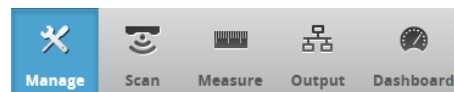

- Go to **Manage** page, **Sensor System** panel, and select the **Visible Sensors** panel.
- The serial number of the Buddy sensor is listed in the Available Sensors panel.

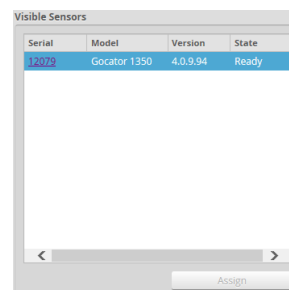

- Select the Buddy sensor and click the **Assign** button.

The Buddy sensor will be assigned to the Main sensor and its status will be updated in the System panel.

The firmware on Main and Buddy sensors must be the same for Buddy assignment to

be successful. If the firmware is different, connect the Main and Buddy sensor one at a time and follow the steps in *Firmware Upgrade* on page 86 to upgrade the sensors.

11. Ensure that the Laser Safety Switch is enabled or the Laser Safety input is high.

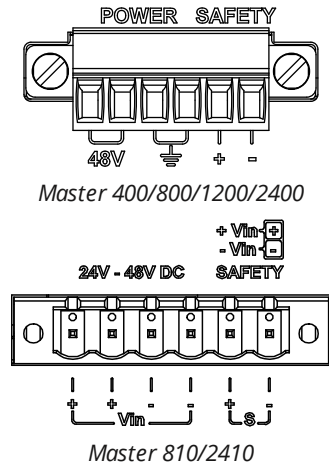

12. Ensure that **Replay** mode is off (the slider is set to the left).
13. Go to the the **Scan** page.
14. Press the **Start** or the **Snapshot** button on the **Toolbar** to start the sensors.
The **Start** button is used to run sensors continuously, while the **Snapshot** button is used to trigger a single measurement.



15. Move a target into the laser plane.
If a target object is within the sensor's measurement range, the data viewer will display scan data, and the sensor's range indicator will illuminate.
If no scan data is displayed in the data viewer, see *Troubleshooting* on page 512.

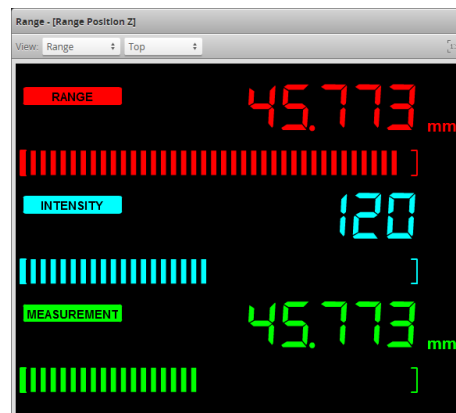

16. Press the **Stop** button if you used the **Start** button to start the sensors.
The laser should turn off.



Required Ports

The following table lists the ports used by sensors, the Ethernet-based protocols, the SDK, and the PC-based accelerator. Use this information to determine whether you need to open ports on your network

and to understand the traffic that a sensor system will produce over a network.

Ports used

Port	Data Packet Protocol	Description
80	TCP	Server for sensor web interface
502	TCP	Modbus protocol communication
2016	UDP	Internal (protocol-independent)
2017	TCP	Internal (protocol-independent)
2018	TCP	Internal (protocol-independent)
2019	TCP	Internal (protocol-independent)
2020	UDP	Gocator protocol discovery; SDK; accelerator
3189	TCP	Flash security policy server (only in Gocator 4.7 and earlier releases)
3190	TCP	Gocator protocol control channel; SDK; accelerator
3191	TCP	Emulator web port
3192	TCP	Gocator protocol upgrade channel; SDK; accelerator
3194	TCP	Gocator protocol health channel; SDK; accelerator
3195	TCP	Gocator protocol private data
3196	TCP	Gocator protocol discovery; SDK; accelerator
3197	UDP	Emulator scenario management (RPC)
3220	UDP	Gocator protocol discovery; SDK; accelerator
8190	TCP	ASCII protocol
44818	TCP	EtherNet/IP protocol (standard port)
44818	UDP	EtherNet/IP protocol (standard port)

For more information on how the different protocols use these ports, see the appropriate section in *Protocols* on page 342.

Next Steps

After you complete the steps in this section, the sensor system is ready to be configured for an application using the software interface. The interface is explained in the following sections:

Management and Maintenance (page 72)

Contains settings for sensor system layout, network, motion and alignment, handling jobs, and sensor maintenance.

Scan Setup and Alignment (page 90)

Contains settings for scan mode, trigger source, detailed sensor configuration, and performing alignment.

Measurement and Processing (page 127)

Contains built-in measurement tools and their settings.

Output (page 234)

Contains settings for configuring output protocols used to communicate measurements to external devices.

Dashboard (page 247)

Provides monitoring of measurement statistics and sensor health.

Toolbar (page 61)

Controls sensor operation, manages jobs, and replays recorded measurement data.

How Gocator Works

The following sections provide an overview of how Gocator acquires and produces data, detects and measures parts, and controls devices such as PLCs. Some of these concepts are important for understanding how you should mount sensors and configure settings such as active area.



You can use the Accelerator to speed up processing of data. For more information, see *Gocator Accelerator* on page 266.

3D Acquisition

After a sensor system has been set up and is running, it is ready to start capturing 3D data.

Gocator laser displacement sensors project a laser point onto the target.



The sensor's camera views the laser line on the target from an angle and captures the reflection of the laser light off the target. The camera captures a single 3D range for each camera exposure. The reflected

laser light falls on the camera at different positions, depending on the distance of the target from the sensor. The sensor's laser emitter, its camera, and the target form a triangle. The sensor uses the known distance between the laser emitter and the camera, and two known angles—one of which depends on the position of the laser light on the camera—to calculate the distance from the sensor to the target. This translates to the height of the target. This method of calculating distance is called *laser triangulation*.

 Gocator sensors are always pre-calibrated to deliver 3D data in engineering units throughout their measurement range.

Clearance Distance and Measurement Range

Clearance distance (CD) and measurement range (MR) are important concepts for understanding the setup of a sensor and for understanding results.

Clearance distance – The minimum distance from the sensor that a target can be scanned and measured. A target closer than this distance will result in invalid data.

Measurement range – The vertical distance, starting at the end of the clearance distance, in which targets can be scanned and measured. Targets beyond the measurement range will result in invalid data.

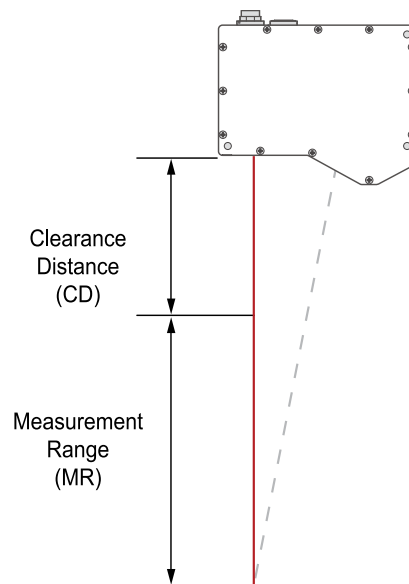

Resolution and Accuracy

The following sections describe Z Resolution and Z Linearity. These terms are used in the Gocator datasheets to describe the measurement capabilities of the sensors.

Z Resolution

Z Resolution gives an indication of the smallest detectable height difference at each point, or how accurately height on a target can be measured. Variability of height measurements at any given moment, in each individual 3D point, with the target at a fixed position, limits Z resolution. This variability is caused by camera and sensor electronics.

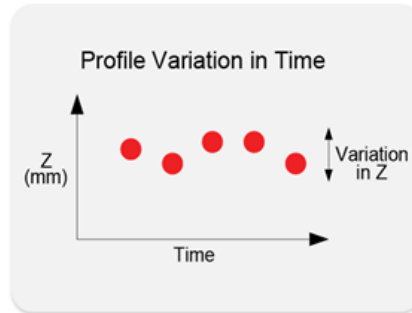

Z resolution is better closer to the sensor. This is reflected in the Gocator datasheets as the two numbers quoted for Z resolution.

Z Linearity

Z linearity is the difference between the actual distance to the target and the measured distance to the target, throughout the measurement range. Z linearity gives an indication of the sensor's ability to measure absolute distance.

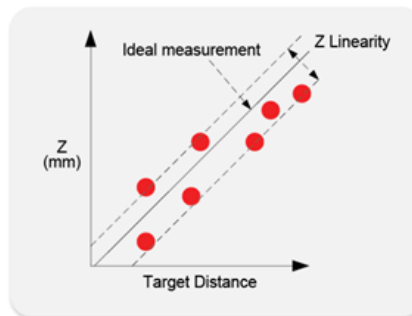

Z linearity is expressed in the Gocator data sheet as a percentage of the total measurement range.

Range Output

Gocator measures the height of the object calculated from laser triangulation. The measurement is referred to as a range and is reported as the distance from the sensor origin.

Coordinate Systems

Range data is reported in one of three coordinate systems, which generally depends on the alignment state of the sensor.

- **Sensor coordinates:** Used on unaligned sensors.
- **System coordinates:** Used on aligned sensors. Applies to either standalone or multi-sensor systems.
- **Part coordinates:** Data can optionally be reported using a coordinate system relative to the part itself.

These coordinate systems are described below.

Sensor Coordinates

Unaligned sensors use *sensor* coordinates: The measurement range (MR) is along the Z axis. Most importantly, the origin is at the *center* of the measurement range.

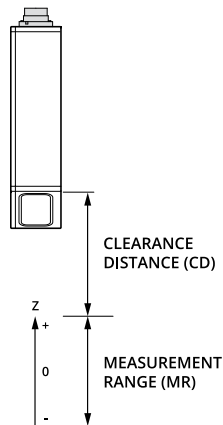

System Coordinates

Aligning sensors adjusts the coordinate system in relation to sensor coordinates, resulting in *system coordinates* (for more information on sensor coordinates, see *Sensor Coordinates* above). For more information on aligning sensors, see *Alignment* on page 106.

The adjustments resulting from alignment are called *transformations* (offsets along the axes and rotations around the axes). Transformations are displayed in the **Sensor** panel on the **Scan** page. For more information on transformations in the web interface, see *Transformations* on page 100.

Alignment is used with a single sensor to compensate for mounting misalignment and to set a zero reference, such as a conveyor belt surface.

Additionally, in multi-sensor systems, alignment sets a common coordinate system. That is, scan data

and measurements from the sensors are expressed in a unified coordinate system.

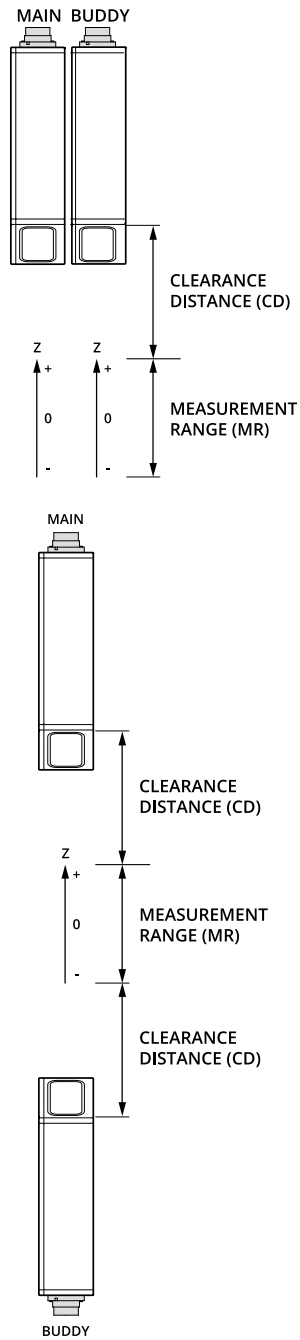

Y angle is positive when rotating from positive X to positive Z axis.

X angle is positive when rotating from positive Y to positive Z. Z angle is positive when rotating from positive X to positive Y.

When applying the transformations, angular rotation is applied before the Z offset.

Data Generation and Processing

After scanning a target, a sensor can process the scan data to allow the use of more sophisticated measurement tools. This section describes the following concepts:

- Profile generation
- Part detection

Profile Generation

Gocator 1300 series, which are displacement sensors and only return a single range value, can combine a series of range values gathered as a target moves under the sensor to generate a profile.

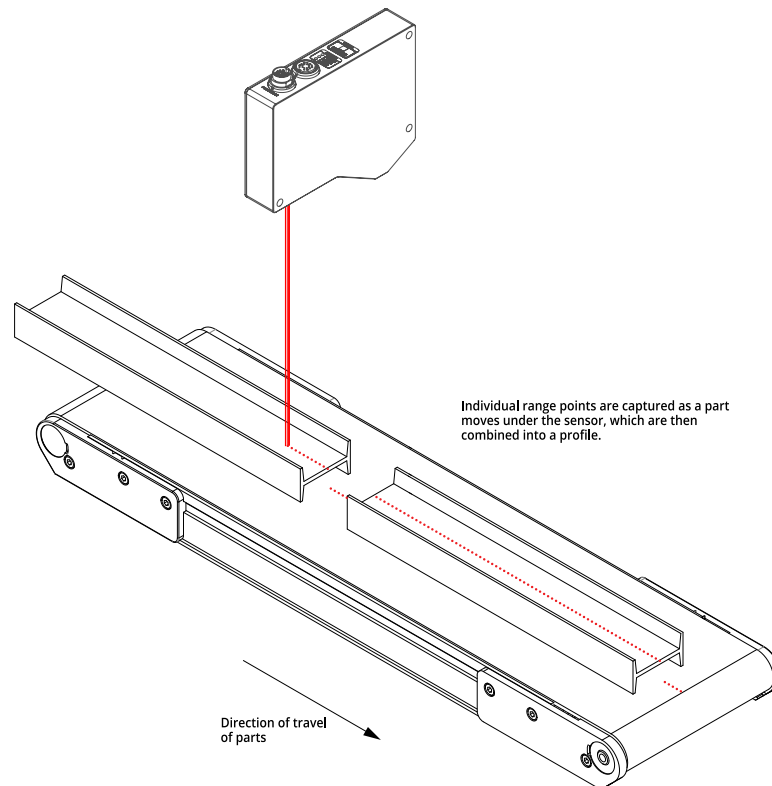

You can then use all the standard [profile measurement tools](#) on the resulting profile:



Part Detection

After a sensor has generated data by combining single exposures into larger pieces of data, the firmware can isolate discrete parts on the generated surface into separate scans representing parts.

Gocator can then perform measurements on these isolated parts.

For more information on part detection, see *Part Detection* on page 118.

Measurement

After Gocator scans a target and, optionally, [further processes](#) the data, the sensor is ready to take measurements on the scan data.

Gocator provides several measurement tools, each of which provides a set of individual measurements, giving you dozens of measurements ideal for a wide variety of applications to choose from. The configured measurements start returning pass/fail decisions, as well as the actual measured values, which are then sent over the enabled output channels to control devices such as PLCs, which can in turn control ejection or sorting mechanisms. (For more information on measurements and configuring measurements, see *Measurement and Processing* on page 127. For more information on output channels, see *Output and Digital Tracking* below.)

 You can create custom tools that run your own algorithms. For more information, see *GDK* on page 491.

A part's position can vary on a transport system. To compensate for this variation, Gocator can anchor a measurement to the positional measurement (X or Z) of an easily detectable feature.

The calculated offset between the two ensures that the anchored measurement will always be properly positioned on different parts.

Output and Digital Tracking

After Gocator has scanned and measured parts, the last step in the operation flow is to output the results and/or measurements.

One of the main functions of Gocator sensors is to produce pass/fail decisions, and then control something based on that decision. Typically, this involves rejecting a part through an eject gate, but it can also involve making decisions on good, but different, parts. This is described as “output” in Gocator. Gocator supports the following output types:

- Ethernet (which provides industry-standard protocols such as Modbus, EtherNet/IP, and ASCII, in addition to the Gocator protocol)
- Digital
- Analog
- Serial interfaces

An important concept is digital output tracking. Production lines can place an ejection or sorting mechanism at different distances from where the sensor scans the target. For this reason, Gocator lets you schedule a delayed decision over the digital interfaces. Because the conveyor system on a typical production line will use an encoder or have a known, constant speed, targets can effectively be “tracked” or “tagged.” Gocator will know when a defective part has traveled far enough and trigger a PLC to activate an ejection/sorting mechanism at the correct moment. For more information on digital output tracking, see *Digital Output* on page 239.

Gocator Web Interface

The following sections describe the Gocator web interface.

Browser Compatibility

LMI recommends Chrome, Firefox, or Edge for use with the Gocator web interface.

Internet Explorer 11 is supported with limitations; for more information, see below.

Internet Explorer 11 Issues

If you use sensors with large datasets on Internet Explorer 11, you may encounter the following issues.

Internet Explorer Switches to Software Rendering

If the PC connected to a sensor is busy, Internet Explorer may switch to software rendering after a specific amount of time. If this occurs, data is not displayed in the data viewer, and the only reliable way to recover from the situation is to restart the browser.

It is possible to remove the time limit that causes this issue, but you must modify the computer's registry. To do so, follow Microsoft's instructions at <https://support.microsoft.com/en-us/help/3099259/update-to-add-a-setting-to-disable-500-msec-time-limit-for-webgl-frame>.

Internet Explorer Displays "Out of Memory"

In some situations, you may encounter "Out of Memory" errors in the sensor's web interface. This issue can be resolved by checking two options in Internet Explorer.

To correct out of memory issues in Internet Explorer 11:

1. In upper right corner, click the settings icon (⚙️), and choose **Internet options**.

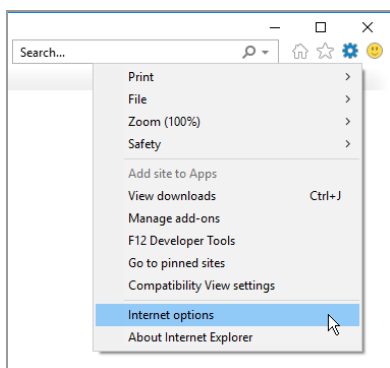

2. In the dialog that opens, click the **Advanced** tab, and scroll down to the **Security** section.

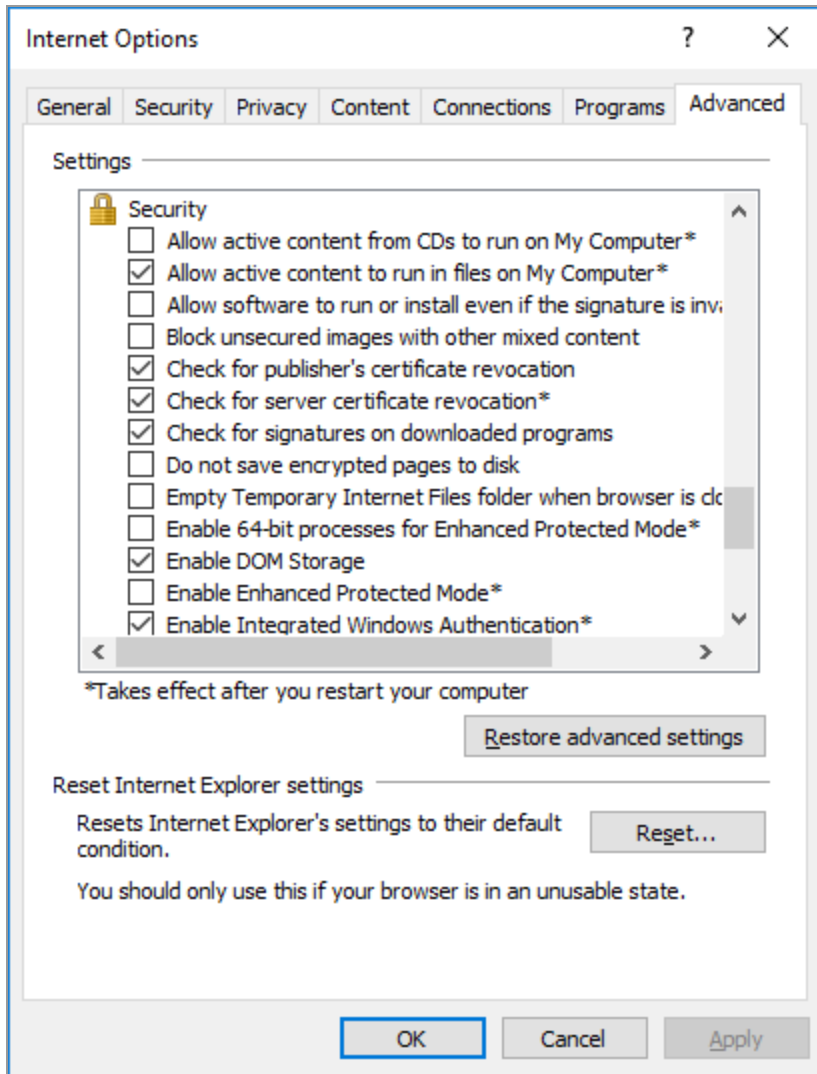

3. In the dialog, check *both* "Enable 64-bit processes for Enhanced Protected Mode" *and* "Enable Enhanced Protected Mode".

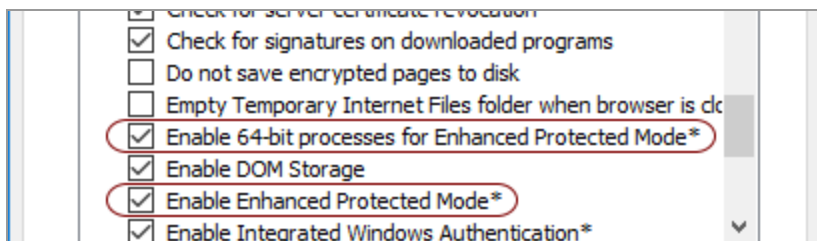

4. Click **OK** and then restart your computer for the changes to take effect.

User Interface Overview

Gocator sensors are configured by connecting to the IP address of a sensor with a web browser.

The web interface is shown below.

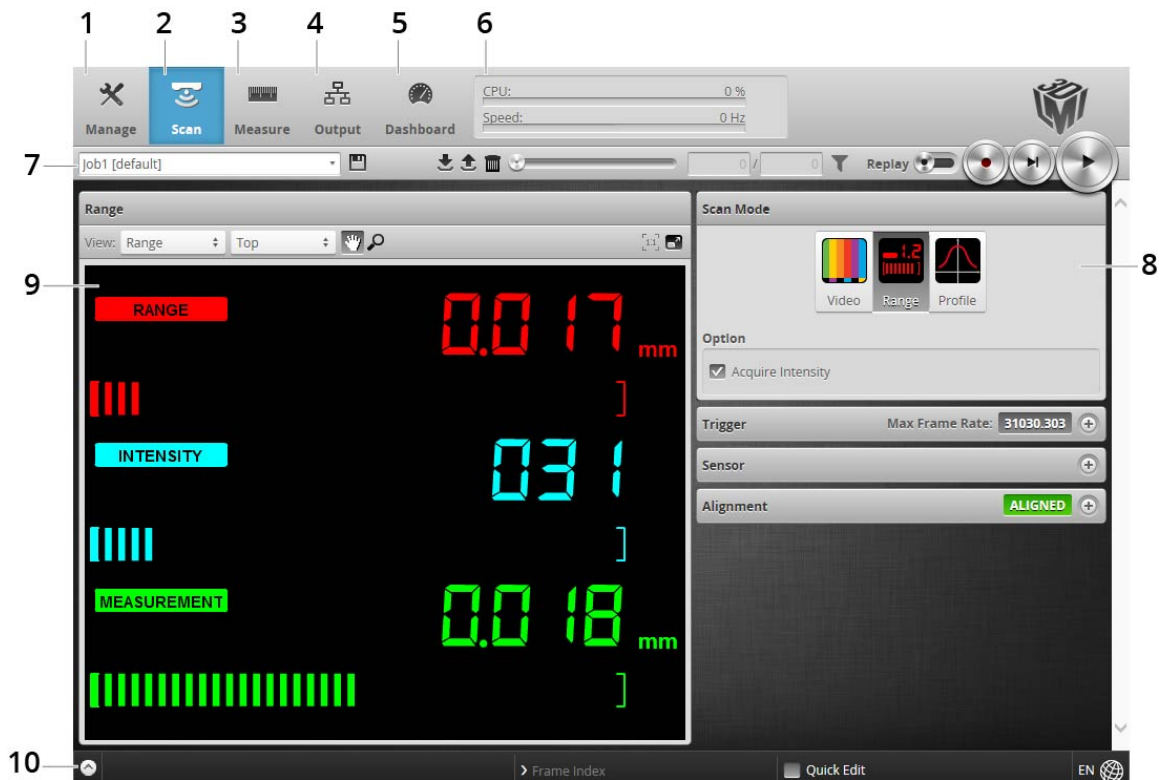

Element	Description
1	Manage page Contains settings for sensor system layout, network, motion and alignment, handling jobs, and sensor maintenance. See <i>Management and Maintenance</i> on page 72.
2	Scan page Contains settings for scan mode, trigger source, detailed sensor configuration, and performing alignment. See <i>Scan Setup and Alignment</i> on page 90.
3	Measure page Contains built-in measurement tools and their settings. See <i>Measurement and Processing</i> on page 127.
4	Output page Contains settings for configuring output protocols used to communicate measurements to external devices. See <i>Output</i> on page 234.
5	Dashboard page Provides monitoring of measurement statistics and sensor health. See <i>Dashboard</i> on page 247.
6	CPU Load and Speed Provides important sensor performance metrics. See <i>Metrics Area</i> on page 68.
7	Toolbar Controls sensor operation, manages jobs, and filters and replays recorded data. See <i>Toolbar</i> on the next page.
8	Configuration area Provides controls to configure scan and measurement tool settings.

Element	Description
9	Data viewer
10	Status bar

Toolbar

The toolbar is used for performing operations such as managing jobs, working with replay data, and starting and stopping the sensor.

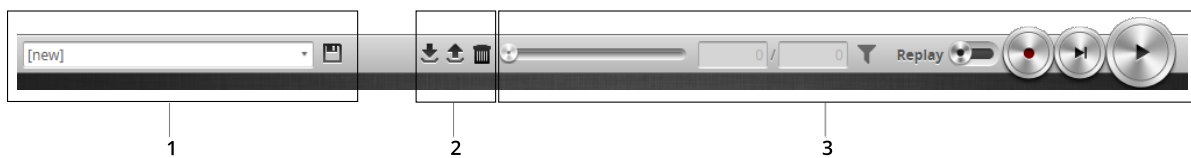

Element	Description
1	Job controls
2	Replay data controls
3	Sensor operation / replay control

Creating, Saving and Loading Jobs (Settings)

A sensor can store several hundred jobs. Being able to switch between jobs is useful when a sensor is used with different constraints during separate production runs. For example, width decision minimum and maximum values might allow greater variation during one production run of a part, but might allow less variation during another production run, depending on the desired grade of the part.

Most of the settings that can be changed in the sensor's web interface, such as the ones in the **Manage**, **Measure**, and **Output** pages, are temporary until saved in a job file. Each sensor can have multiple job files. If there is a job file that is designated as the default, it will be loaded automatically when the sensor is reset.

When you change sensor settings using the sensor web interface in the emulator, some changes are saved automatically, while other changes are temporary until you save them manually. The following table lists the types of information that can be saved in a sensor.

Setting Type	Behavior
Job	Most of the settings that can be changed in the sensor's web interface, such as the ones in the Manage , Measure , and Output pages, are temporary until saved in a job file. Each sensor can have multiple job files. If there is a job file that is designated as the default, it will be loaded automatically when the sensor is reset.

Setting Type	Behavior
Alignment	Alignment can either be fixed or dynamic, as controlled by the Alignment Reference setting in Motion and Alignment in the Manage page. Alignment is saved automatically at the end of the alignment procedure when Alignment Reference is set to Fixed . When Alignment Reference is set to Dynamic , however, you must manually save the job to save alignment.
Network Address	Network address changes are saved when you click the Save button in Networking on the Manage page. The sensor must be reset before changes take effect.

The job drop-down list in the toolbar shows the jobs stored in the sensor. The job that is currently active is listed at the top. The job name will be marked with "[unsaved]" to indicate any unsaved changes.



To create a job:

1. Choose **[New]** in the job drop-down list and type a name for the job.
2. Click the **Save** button  or press **Enter** to save the job.
The job is saved to sensor storage using the name you provided. Saving a job automatically sets it as the default, that is, the job loaded when then sensor is restarted.

To save a job:

- Click the **Save** button .
- The job is saved to sensor storage. Saving a job automatically sets it as the default, that is, the job loaded when then sensor is restarted.

To load (switch) jobs:

- Select an existing file name in the job drop-down list.
- The job is activated. If there are any unsaved changes in the current job, you will be asked whether you want to discard those changes.

You can perform other job management tasks—such as downloading job files from a sensor to a computer, uploading job files to a sensor from a computer, and so on—in the **Jobs** panel in the **Manage** page. See *Jobs* on page 81 for more information.

Recording, Playback, and Measurement Simulation

Sensors can record and replay recorded scan data, and also simulate measurement tools on recorded data. This feature is most often used for troubleshooting and fine-tuning measurements, but can also be helpful during setup.

Recording and playback are controlled using the toolbar controls.



Recording and playback controls when replay is off

To record live data:

1. Toggle **Replay** mode off by setting the slider to the left in the **Toolbar**.

 Replay mode disables measurements.

2. (Optional) Configure recording filtering.
For more information on recording filtering, see *Recording Filtering* on page 65.
3. Click the **Record** button to enable recording.



The center of the Record button turns red.

When recording is enabled (and replay is off), the sensor will store the most recent data as it runs. Remember to disable recording if you no longer want to record live data. (Press the **Record** button again to disable recording).

4. Press the **Snapshot** button or **Start** button.
The **Snapshot** button records a single frame. The **Start** button will run the sensor continuously and all frames will be recorded, up to available memory. When the memory limit is reached, the oldest data will be discarded.

 Newly recorded data is appended to existing replay data unless the sensor job has been modified.

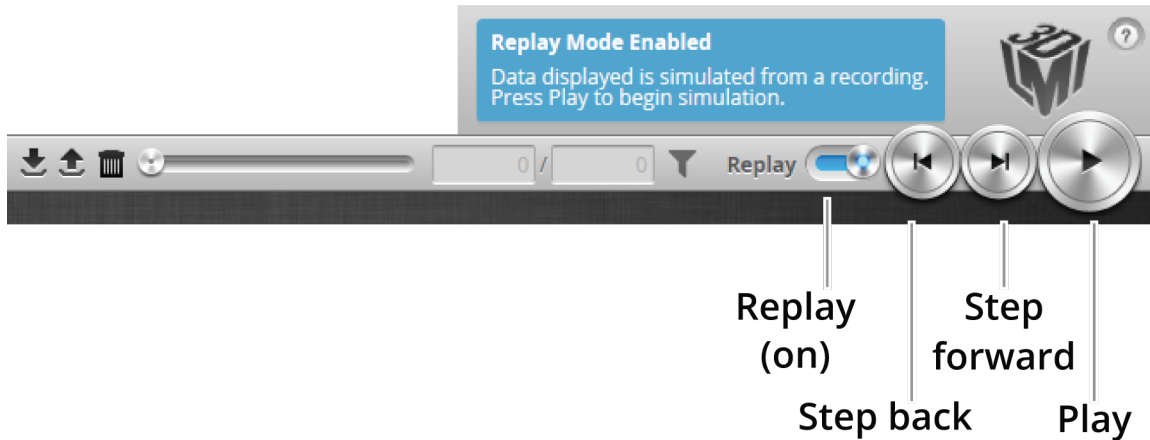

Playback controls when replay is on

To replay data:

1. Toggle **Replay** mode on by setting the slider to the right in the **Toolbar**.
The slider's background turns blue and a Replay Mode Enabled message is displayed.
2. Use the **Replay** slider or the **Step Forward**, **Step Back**, or **Play** buttons to review data.
The **Step Forward** and **Step Back** buttons move the current replay location forward and backward by a single frame, respectively.
The **Play** button advances the replay location continuously, animating the playback until the end of the replay data.
The **Stop** button (replaces the **Play** button while playing) can be used to pause the replay at a particular location.
The **Replay** slider (or **Replay Position** box) can be used to go to a specific replay frame.

To simulate measurements on replay data:

1. Toggle **Replay** mode on by setting the slider to the right in the **Toolbar**.
The slider's background turns blue and a Replay Mode Enabled message is displayed.
To change the mode, **Replay Protection** must be unchecked.
2. Go to the **Measure** page.
Modify settings for existing measurements, add new measurement tools, or delete measurement tools as desired. For information on adding and configuring measurements, see *Measurement and Processing* on page 127.
3. Use the **Replay Slider**, **Step Forward**, **Step Back**, or **Play** button to simulate measurements.
Step or play through recorded data to execute the measurement tools on the recording.
Individual measurement values can be viewed directly in the data viewer. Statistics on the measurements that have been simulated can be viewed in the **Dashboard** page; for more information on the dashboard, see *Dashboard* on page 247.

To clear replay data:

1. Stop the sensor if it is running by clicking the **Stop** button.
2. Click the **Clear Replay Data** button .

Recording Filtering

Replay data is often used for troubleshooting. But replay data can contain thousands of frames, which makes finding a specific frame to troubleshoot difficult. Recording filtering lets you choose which frames the sensor records, based on one or more conditions, which makes it easier to find problems.

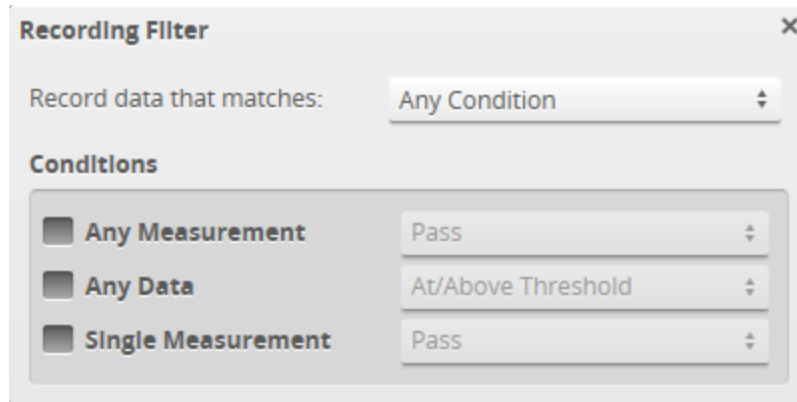

How a sensor treats conditions

Setting	Description
Any Condition	The sensor records a frame when any condition is true.
All Conditions	The sensor only records a frame if all conditions are true.

Conditions

Setting	Description
Any Measurement	The sensor records a frame when <i>any</i> measurement is in the state you select. The following states are supported: <ul style="list-style-type: none">• pass• fail or invalid• fail and valid• valid• invalid
Single Measurement	The sensor records a frame if the measurement with the ID you specify in ID is in the state you select. This setting supports the same states as the Any Measurement setting (see above).
Any Data	At/Above Threshold: The sensor records a frame if the number of valid points in the frame is above the value you specify in Range Count Threshold . Below Threshold: The sensor records a frame if the number of valid points is below the threshold you specify.

To set recording filtering:

1. Make sure recording is enabled by clicking the Record button.



2. Click the Recording Filtering button .
3. In the Recording Filtering dialog, choose how the sensor treats conditions:
For information on the available settings, see *How a sensor treats conditions* on the previous page.
4. Configure the conditions that will cause the sensor to record a frame:
For information on the available settings, see *Conditions* on the previous page.
5. Click the "x" button or outside of the Recording Filtering dialog to close the dialog.
The recording filter icon turns green to show that recording filters have been set.
When you run the sensor, it only records the frames that satisfy the conditions you have set.

Downloading, Uploading, and Exporting Replay Data

Replay data (recorded scan data) can be downloaded from a sensor to a client computer, or uploaded from a client computer to a sensor.

Data can also be exported from a sensor to a client computer in order to process the data using third-party tools.

You can only upload replay data to the same sensor model that was used to create the data.

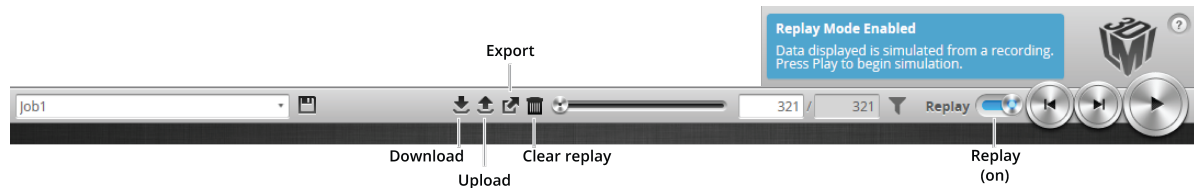

Replay data is not loaded or saved when you load or save jobs.

To download replay data:

1. Click the Download button .
2. In the **File Download** dialog, click **Save**.
3. In the **Save As...** dialog, choose a location, optionally change the name, and click **Save**.

To upload replay data:

1. Click the Upload button .
The Upload menu appears.

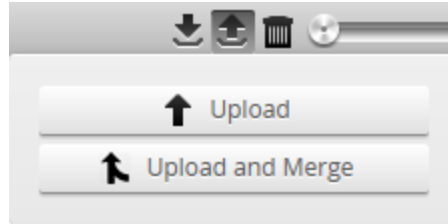

2. In the Upload menu, choose one of the following:
 - **Upload:** Unloads the current job and creates a new unsaved and untitled job from the content of the replay data file.
 - **Upload and merge:** Uploads the replay data and merges the data's associated job with the current job. Specifically, the settings on the **Scan** page are overwritten, but all other settings of the current job are preserved, including any measurements.

If you have unsaved changes in the current job, the firmware asks whether you want to discard the changes.

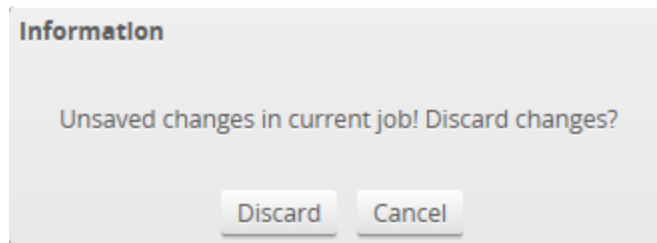

3. Do one of the following:
 - Click **Discard** to discard any unsaved changes.
 - Click **Cancel** to return to the main window to save your changes.
4. If you clicked **Discard**, navigate to the replay data to upload from the client computer and click **OK**. The replay data is loaded, and a new unsaved, untitled job is created.

Replay data can be exported using the CSV format. If you have enabled **Acquire Intensity** in the **Scan Mode** panel on the **Scan** page, the exported CSV file includes intensity data.

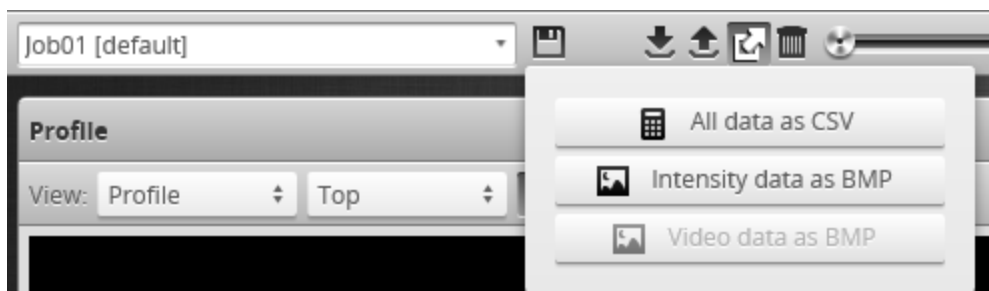

To export replay data in the CSV format:

1. In the **Scan Mode** panel, switch to Range or Profile.

2. Switch to Replay mode.
3. Click the Export button  and select **All Data as CSV**.
In Profile mode, all data in the record buffer is exported. data at the current replay location is exported. Use the playback control buttons to move to a different replay location; for information on playback, see *To replay data in Recording, Playback, and Measurement Simulation* on page 62.
4. (Optional) Convert exported data to another format using the CSV Converter Tool. For information on this tool, see *CSV Converter Tool* on page 505.

 The decision values in the exported data depend on the *current* state of the job, not the state during recording. For example, if you record data when a measurement returns a *pass* decision, change the measurement's settings so that a *fail* decision is returned, and then export to CSV, you will see a *fail* decision in the exported data.

Recorded intensity data can be exported to a bitmap (.BMP format). **Acquire Intensity** must be checked in the **Scan Mode** panel while data was being recorded in order to export intensity data.

To export recorded intensity data to the BMP format:

- Switch to Replay mode and click the **Export** button  and select **Intensity data as BMP**.

Only the intensity data in the current replay location is exported.

Use the playback control buttons to move to a different replay location; for information on playback, see *To replay data in Recording, Playback, and Measurement Simulation* on page 62.



To export video data to a BMP file:

1. In the **Scan Mode** panel, switch to Video mode.
Use the playback control buttons to move to a different replay location; for information on playback, see *To replay data in Recording, Playback, and Measurement Simulation* on page 62.
2. Switch to Replay mode.
3. Click the Export button  and select **Video data as BMP**.

Metrics Area

The **Metrics** area displays two important sensor performance metrics: CPU load and speed (current frame rate).

The **CPU** bar in the **Metrics** panel (at the top of the interface) displays how much of the CPU is being utilized. A warning symbol (⚠️) will appear next to the **CPU** bar if the sensor drops data because the CPU is over-loaded.

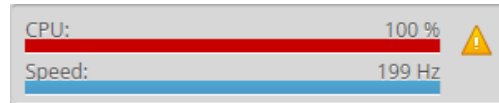

CPU at 100%

The **Speed** bar displays the frame rate of the sensor. A warning symbol (⚠️) will appear next to it if triggers (external input or encoder) are dropped because the external rate exceeds the maximum frame rate.

Open the log for details on the warning. For more information on logs, see *Log* below.

When a sensor is [accelerated](#) a "rocket" icon appears in the metrics area.



Data Viewer

The data viewer is displayed in both the **Scan** and the **Measure** pages, but displays different information depending on which page is active.

When the **Scan** page is active, the data viewer displays sensor data and can be used to adjust the active area and other settings. Depending on the selected operation mode (page 91), the data viewer can display video images, ranges, or profiles. For details, see *Data Viewer* on page 120.

When the **Measure** page is active, the data viewer displays sensor data onto which representations of measurement tools and their measurements are superimposed. For details, see *Data Viewer* on page 127.

Status Bar

The status bar lets you do the following:

- See sensor messages in the [log](#).
- See [frame information](#).
- Change the [interface language](#).
- Switch to [Quick Edit mode](#).

Log

The log, located at the bottom of the web interface, is a centralized location for all messages that the sensor displays, including warnings and errors.

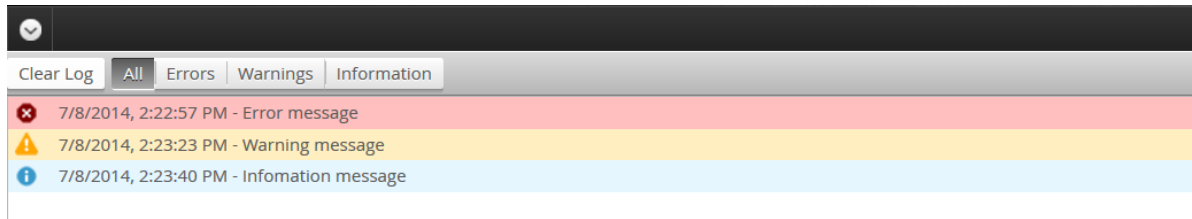

A number indicates the number of unread messages:



To use the log:

1. Click on the Log open button  at the bottom of the web interface.
2. Click on the appropriate tab for the information you need.

Frame Information

The area to the right of the status bar displays useful frame information, both when the sensor is running and when viewing recorded data.



This information is especially useful when you have enabled [recording filtering](#). If you look at a recording playback, when you have enabled recording filtering, some frames can be excluded, resulting in variable "gaps" in the data.

The following information is available:

Frame Index: Displays the index in the data buffer of the current frame. The value resets to 0 when the sensor is restarted or when recording is enabled.

Master Time: Displays the recording time of the current frame, with respect to when the sensor was started.

Encoder Index: Displays the encoder value at the time of the last encoder Z index pulse. Note this is not the same as the encoder value at the time the frame was captured.

Timestamp: Displays the timestamp the current frame, in microseconds from when the sensor was started.

To switch between types of frame information:

- Click the frame information area to switch to the next available type of information.

Quick Edit Mode

When working with a very large number of [measurement tools](#) (for example, a few dozen) or a very complex user-created [GDK tool](#), you can switch to a "Quick Edit" mode to make configuration faster.



When this mode is enabled, the data viewer and measurement results are not refreshed after each setting change. Also, when Quick Edit is enabled, in Replay mode, [stepping through frames](#) or playing back scan data does not change the displayed frame.

 When a sensor is running, Quick Edit mode is ignored: all changes to settings are reflected immediately in the data viewer.

Interface Language

The language button on the right side of the status bar at the bottom of the interface lets you change the language of the interface.



To change the language:

1. Click the language button at the bottom of the web interface.



2. Choose a language from the list.



The interface reloads on the page you were working in, displaying the page using the language you chose. The sensor state is preserved.

Management and Maintenance

The following sections describe how to set up the sensor connections and networking, how to calibrate encoders and choose the alignment reference, and how to perform maintenance tasks.

Manage Page Overview

The sensor's system and maintenance tasks are performed on the **Manage** page.

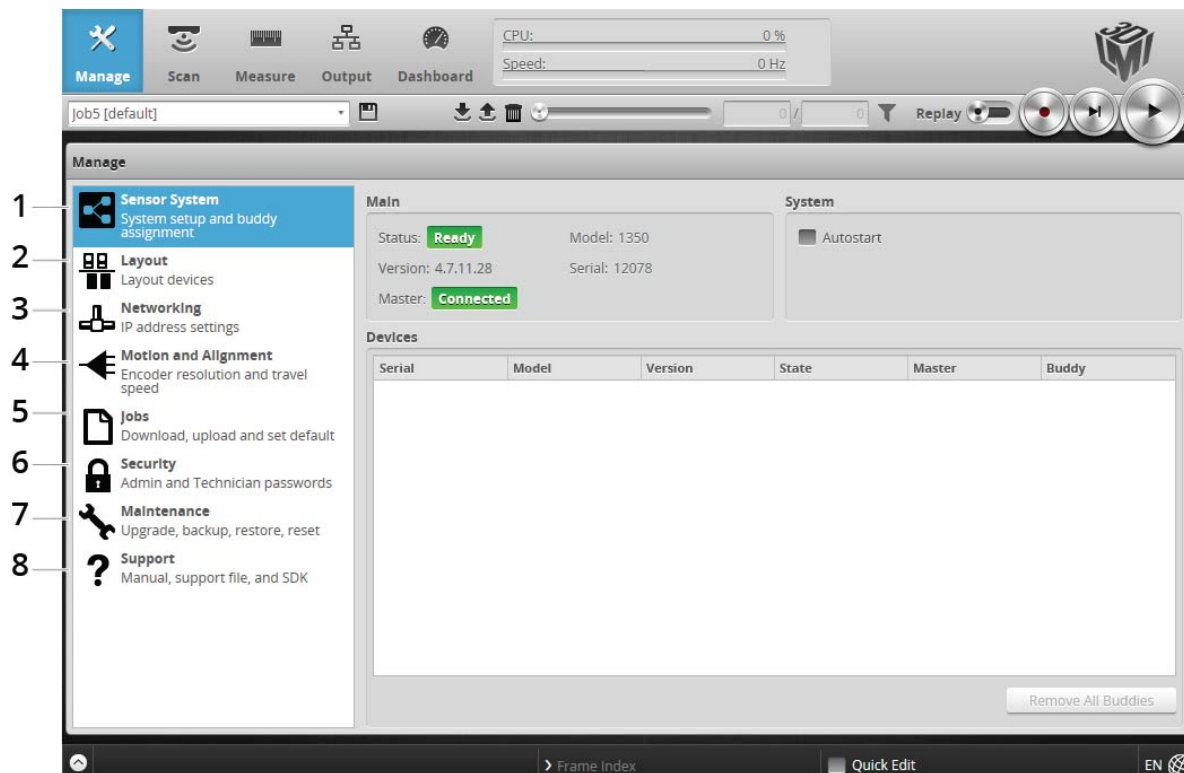

Element	Description
1	Sensor System Contains sensor information, buddy assignment, and the autostart setting. See <i>Sensor System</i> on the next page.
2	Layout Contains settings for configuring dual-sensor system layouts.
3	Networking Contains settings for configuring the network. See <i>Networking</i> on page 78.
4	Motion and Alignment Contains settings to configure the encoder. See <i>Motion and Alignment</i> on page 79.
5	Jobs Lets you manage jobs stored on the sensor. See <i>Jobs</i> on page 81.
6	Security Lets you change passwords. See <i>Security</i> on page 83.
7	Maintenance Lets you upgrade firmware, create/restore backups, and reset sensors. See <i>Maintenance</i> on page 84.

Element	Description
8 Support	Lets you open an HTML version or download a PDF version of the manual, download the SDK, or save a support file. Also provides device information. See <i>Support</i> on page 87

Sensor System

The following sections describe the **Sensor System** category on the **Manage** page. This category provides sensor information and the autostart setting. It also lets you choose which sensors to add to a dual-sensor system.

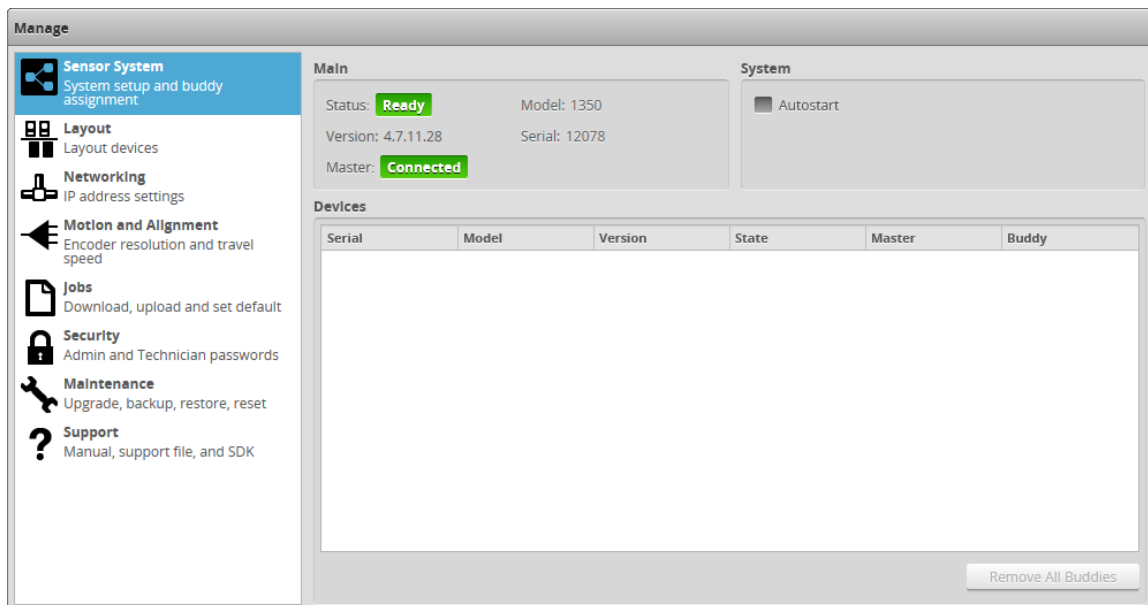

Dual- and Multi-sensor Systems

Gocator supports dual-sensor systems. In these systems, data from each sensor is combined into a single range or profile. Any [measurements](#) you configure work on the combined data.

The sensors lets you easily and quickly set up dual-sensor systems from the web interface. Setting up these systems involves two steps:

1. Assigning an additional sensor, called the *Buddy* sensor, to the *Main* sensor. For more information, see *Buddy Assignment* below.
2. Choosing the layout of the dual-sensor system. For more information, see *Layout* on page 75.

Buddy Assignment

In a dual-sensor system, the *Main* sensor controls a second sensor, called the *Buddy* sensor, after the Buddy sensor is assigned to the Main sensor. You configure both sensors through the Main sensor's interface.

 Main and Buddy sensors must be assigned unique IP addresses before they can be used on the

same network. Before proceeding, connect the Main and Buddy sensors one at a time (to avoid an address conflict) and use the steps described in Running a Dual-Sensor System (page 30) to assign each sensor a unique address.

When a sensor is acting as a Buddy, it is not discoverable and its web interface is not accessible.

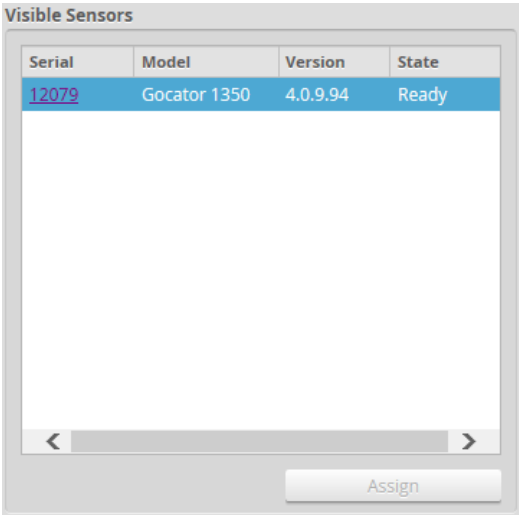

A sensor can only be assigned as a Buddy if its firmware and model number match the firmware and model number of the Main sensor.

To assign a Buddy sensor:

1. Go to the **Manage** page and click on the **Sensor System** category.
2. In the **Visible Sensors** list, click the "plus" icon next to the sensor you want to add as a Buddy. The sensor you added to the system appears in a **Buddies** list.

Serial	Model	Version	State	Master	Buddy
Buddies					
40276	Gocator 2420	4.6.5.53	Connected	Connected	⊖
Visible Sensors					
40166	Gocator 2420	4.6.5.53	Connectable	-	⊕
40279	Gocator 2420	4.6.5.53	Connectable	-	⊕
40278	Gocator 2420	4.6.5.53	Connectable	-	⊕

3. Repeat the previous step to add more sensors to the system.

To remove a Buddy, click the "minus" icon next to the sensor you want to remove. To remove all Buddies, click **Remove All Buddies**.

Over Temperature Protection

Sensors equipped with a 3B-N laser by default will turn off the laser if the temperature exceeds the safe operating range. You can override the setting by disabling the overheat protection.



Disabling the setting is not recommended. Disabling the overheat protection feature could lead to premature laser failure if the sensor operates outside the specified temperature range.

Over Temperature Shutoff

To enable/disable overheat temperature protection:

1. Check/uncheck the **Over Temperature Shutoff** option.
2. Save the job file.

Sensor Autostart

With the **Autostart** setting enabled, scanning and measurements begin automatically when the sensor is powered on. Autostart must be enabled if the sensor will be used without being connected to a computer.

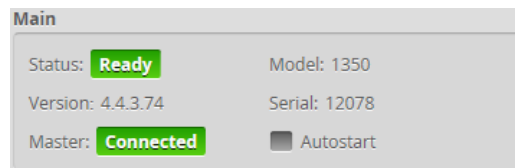

To enable/disable Autostart:

1. Go to the **Manage** page and click on the **Sensor System** category.
2. Check/uncheck the **Autostart** option in the **Main** section.

Layout

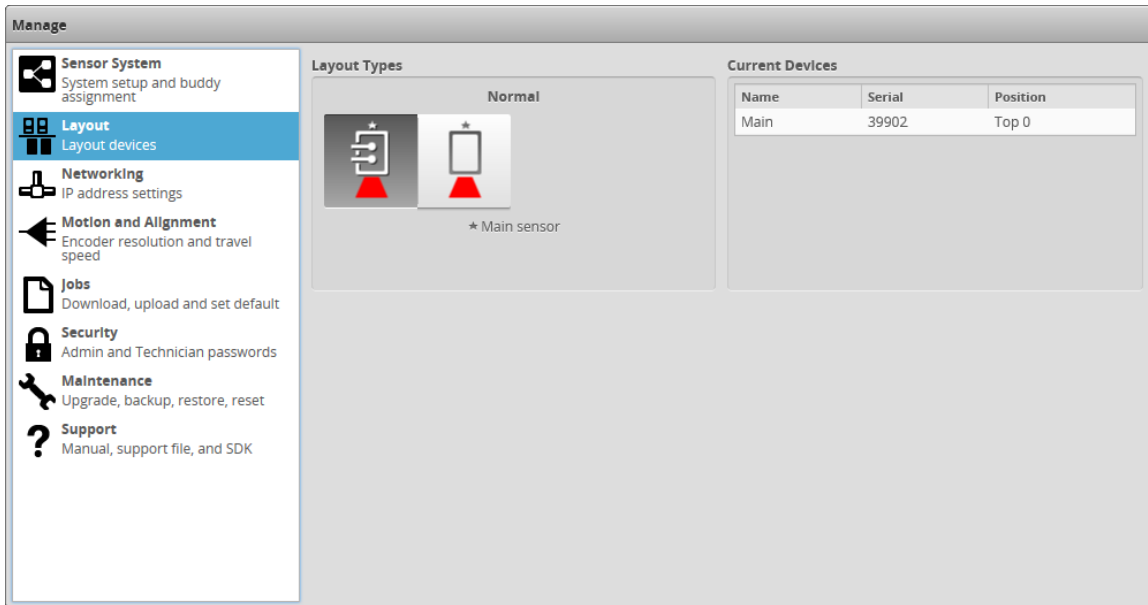

The following sections describe the **Layout** category on the **Manage** page. This category lets you configure dual-sensor systems.



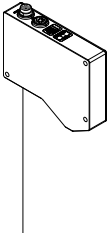

Mounting orientations must be specified for a dual- or multi-sensor system. This information allows the alignment procedure to determine the correct system-wide coordinates for laser ranging and measurements. For more information on sensor and system coordinates, see *Coordinate Systems* on page 54.

 Dual layouts are only displayed when a Buddy sensor has been assigned.

Supported Layouts

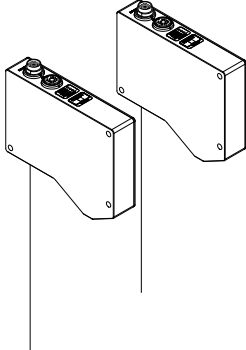
Layout Type	Example
 <p>Normal The sensor operates as an isolated device.</p>	
 <p>Reverse The sensor operates as an isolated device, but in a reverse orientation. You can use this layout to change the handedness of the data.</p>	

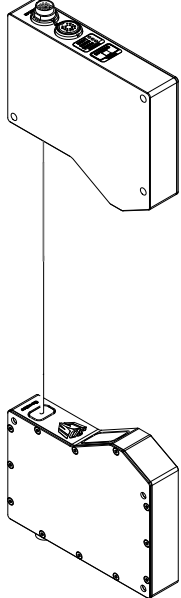
Layout Type	Example
 <p>Wide Sensors are mounted in Left (Main) and Right (Buddy) positions. This allows for measuring the height of the object at multiple points.</p>	
 <p>Reverse Sensors are mounted in a left-right layout as with the Wide layout, but the Buddy sensor is mounted such that it is rotated 180 degrees around the Z axis to prevent occlusion along the Y axis. Sensors should be shifted along the Y axis so that the laser lines align.</p>	
 <p>Opposite Sensors are mounted in Top (Main) and Bottom (Buddy) positions for measuring thickness .</p>	

To specify a standalone layout:

1. Go to the **Manage** page and click on the **Layout** category.
2. Under **Layout Types**, choose Normal or Reverse layout by clicking one of the layout buttons.

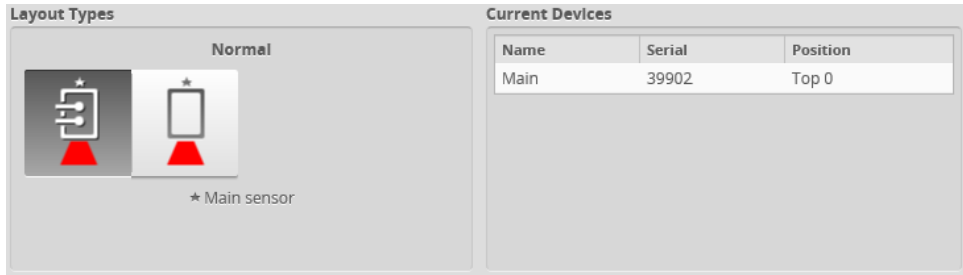

See the table above for information on layouts.

Before you can select a dual-sensor layout, you must assign a second sensor as the Buddy sensor. For more information, see *Dual- and Multi-sensor Systems* on page 73.

To specify a dual-sensor layout:

1. Go to the **Manage** page and click on the **Layout** category.
2. Under **Layout Types**, choose a layout by clicking one of the layout buttons.

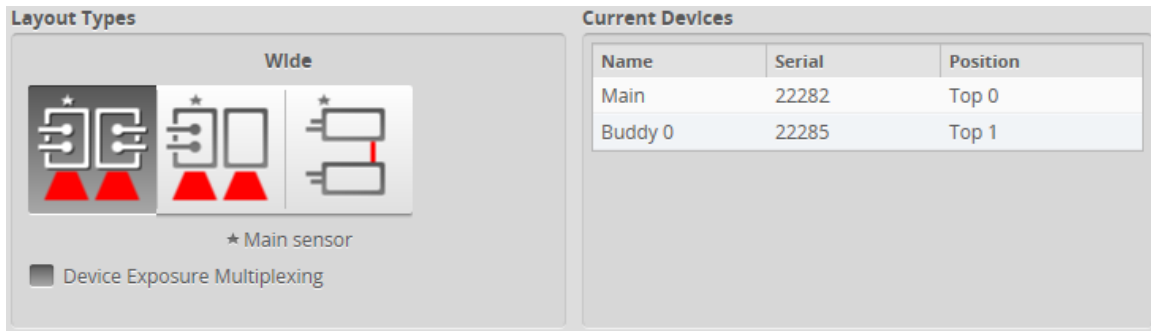

See the table above for information on layouts.

Before you can select a multi-sensor layout, you must assign two or more additional sensors as Buddy sensors. For more information, see *Dual- and Multi-sensor Systems* on page 73.

Networking

The **Networking** category on the **Manage** page provides network settings. Settings must be configured to match the network to which the sensors are connected.

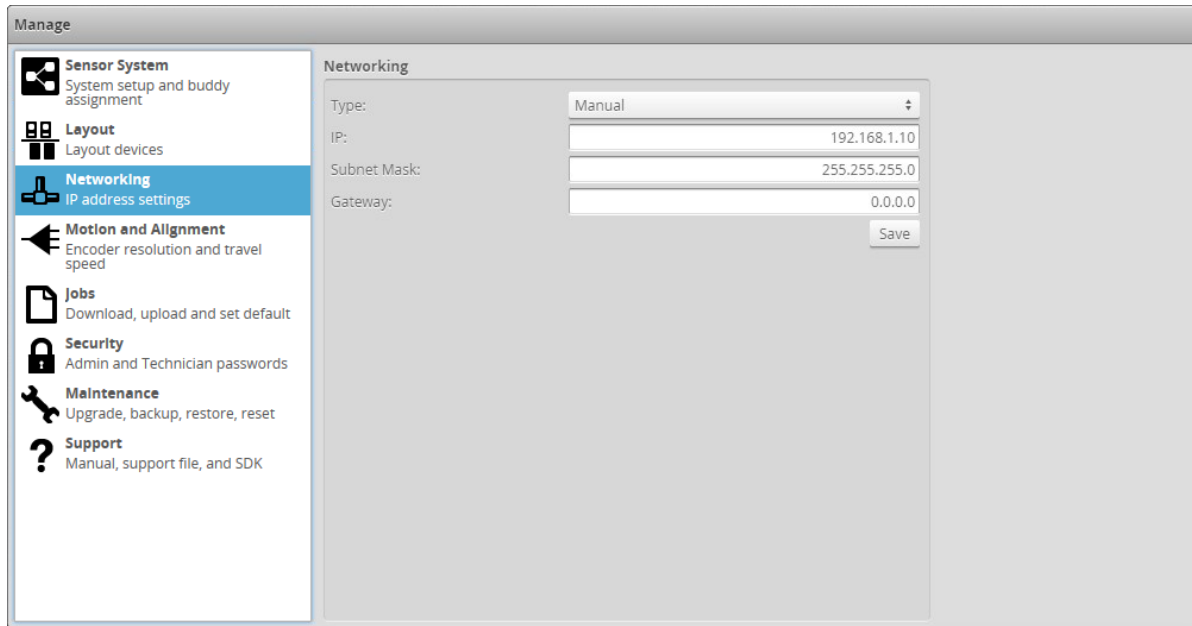

To configure the network settings:

1. Go to the **Manage** page.
2. In the **Networking** category, specify the Type, IP, Subnet Mask, and Gateway settings.
The sensor can be configured to use DHCP or assigned a static IP address by selecting the appropriate option in the **Type** drop-down.
3. Click on the **Save** button.
You will be prompted to confirm your selection.

Motion and Alignment

The **Motion and Alignment** category on the **Manage** page lets you configure alignment reference, encoder resolution, and travel speed, and confirm that encoder signals are being received by the sensor.

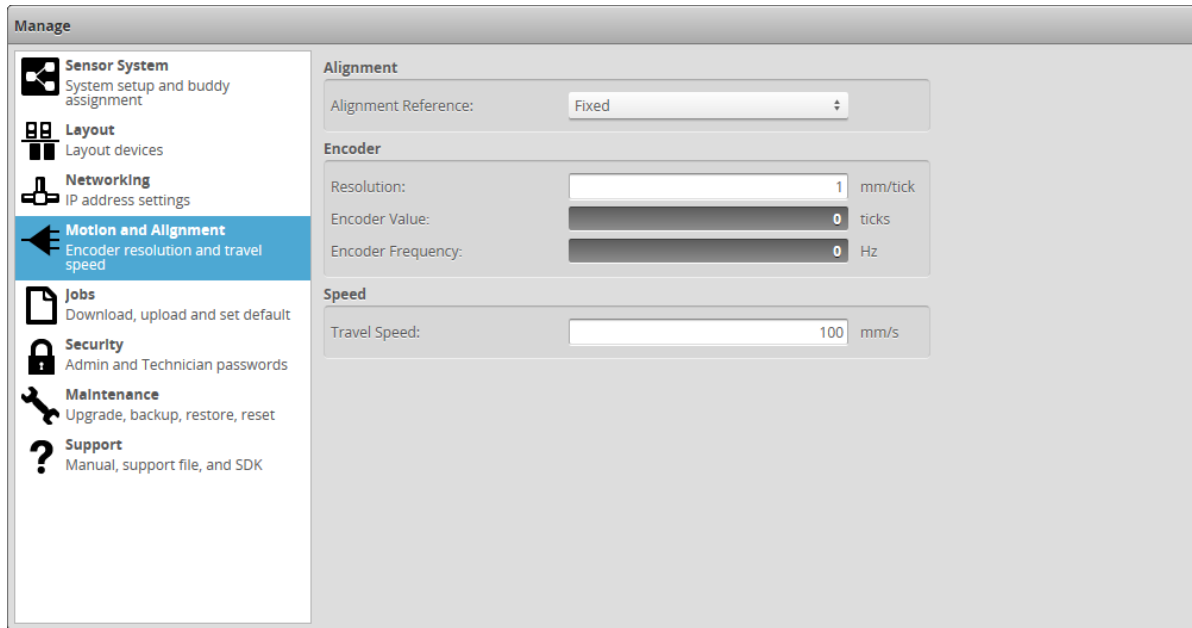

Alignment Reference

The **Alignment Reference** setting can have one of two values: **Fixed** or **Dynamic**.

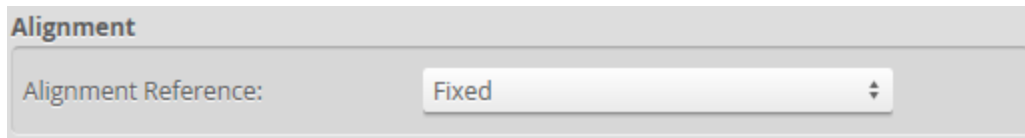

Setting	Description
Fixed	A single, global alignment is used for all jobs. This is typically used when the sensor mounting is constant over time and between scans, for example, when the sensor is mounted in a permanent position over a conveyor belt.
Dynamic	A separate alignment is used for each job. This is typically used when the sensor's position relative to the object scanned is always changing, for example, when the sensor is mounted on a robot arm moving to different scanning locations.

To configure alignment reference:

1. Go to the **Manage** page and click on the **Motion and Alignment** category.
2. In the Alignment section, choose **Fixed** or **Dynamic** in the **Alignment Reference** drop-down.

Encoder Resolution

You can manually enter the encoder resolution in the **Resolution** setting, or it can be automatically set by performing an alignment with **Type** set to **Moving**. Establishing the correct encoder resolution is required for correct scaling of the scan of the target object in the direction of travel.

Encoder

Resolution: mm/tick

Encoder Value: ticks

Encoder Frequency: Hz

Encoder resolution is expressed in millimeters per tick, where one tick corresponds to *one* of the four encoder quadrature signals (A+ / A- / B+ / B-).

 Encoders are normally specified in *pulses* per revolution, where each pulse is made up of the four quadrature *signals* (A+ / A- / B+ / B-). Because the sensor reads each of the four quadrature signals, you should choose an encoder accordingly, given the resolution required for your application.

To configure encoder resolution:

1. Go to the **Manage** page and click on the **Motion and Alignment** category.
2. In the **Encoder** section, enter a value in the **Resolution** field.

Encoder Value and Frequency

The encoder value and frequency are used to confirm the encoder is correctly wired to the sensor and to manually calibrate encoder resolution (that is, by moving the conveyor system a known distance and making a note of the encoder value at the start and end of movement).

Travel Speed

The **Travel Speed** setting is used to correctly scale scans in the direction of travel in systems that lack an encoder but have a conveyor system that is controlled to move at constant speed. Establishing the correct travel speed is required for correct scaling of the scan in the direction of travel.

Speed

Travel Speed: mm/s

Travel speed is expressed in millimeters per second.

To manually configure travel speed:

1. Go to the **Manage** page and click on the **Motion and Alignment** category.
2. In the **Speed** section, enter a value in the **Travel Speed** field.

Travel speed can also be set automatically by performing an alignment with **Type** set to **Moving** (see *Aligning Sensors* on page 107).

Jobs

The **Jobs** category on the **Manage** page lets you manage the jobs stored on a sensor.

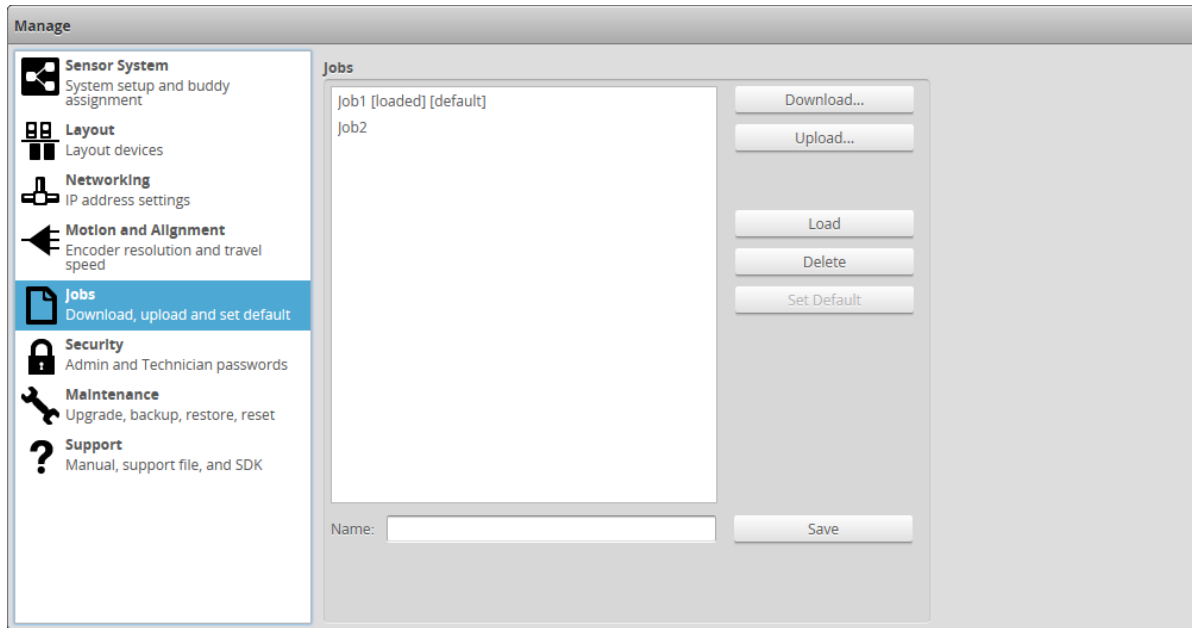

Element	Description
Name field	Used to provide a job name when saving files.
Jobs list	Displays the jobs that are currently saved in the sensor's flash storage.
Save button	Saves current settings to the job using the name in the Name field.
Load button	Loads the job that is selected in the job list. Reloading the current job discards any unsaved changes.
Delete button	Deletes the job that is selected in the job list.
Set as Default button	Sets the selected job as the default to be loaded when the sensor starts. When the default job is selected, this button is used to clear the default.
Download... button	Downloads the selected job to the client computer.
Upload... button	Uploads a job from the client computer.

Jobs can be loaded (currently activated in sensor memory) and set as default independently. For example, Job1 could be loaded, while Job2 is set as the default. Default jobs load automatically when a sensor is power cycled or reset.

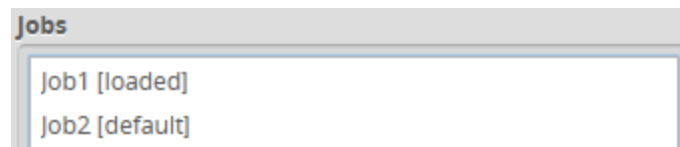

Unsaved jobs are indicated by "[unsaved]".

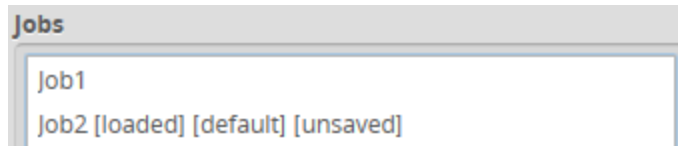

To save a job:

1. Go to the **Manage** page and click on the **Jobs** category.
2. Provide a name in the **Name** field.
To save an existing job under a different name, click on it in the **Jobs** list and then modify it in the **Name** field.
3. Click on the **Save** button or press **Enter**.
Saving a job automatically sets it as the default, that is, the job loaded when then sensor is restarted.

To download, load, or delete a job, or to set one as a default, or clear a default:

1. Go to the **Manage** page and click on the **Jobs** category.
2. Select a job in the **Jobs** list.
3. Click on the appropriate button for the operation.

Security

You can prevent unauthorized access to a sensor by setting passwords. Each sensor has two accounts: Administrator and Technician.

By default, no passwords are set. When you start a sensor, you are prompted for a password only if a password has been set.

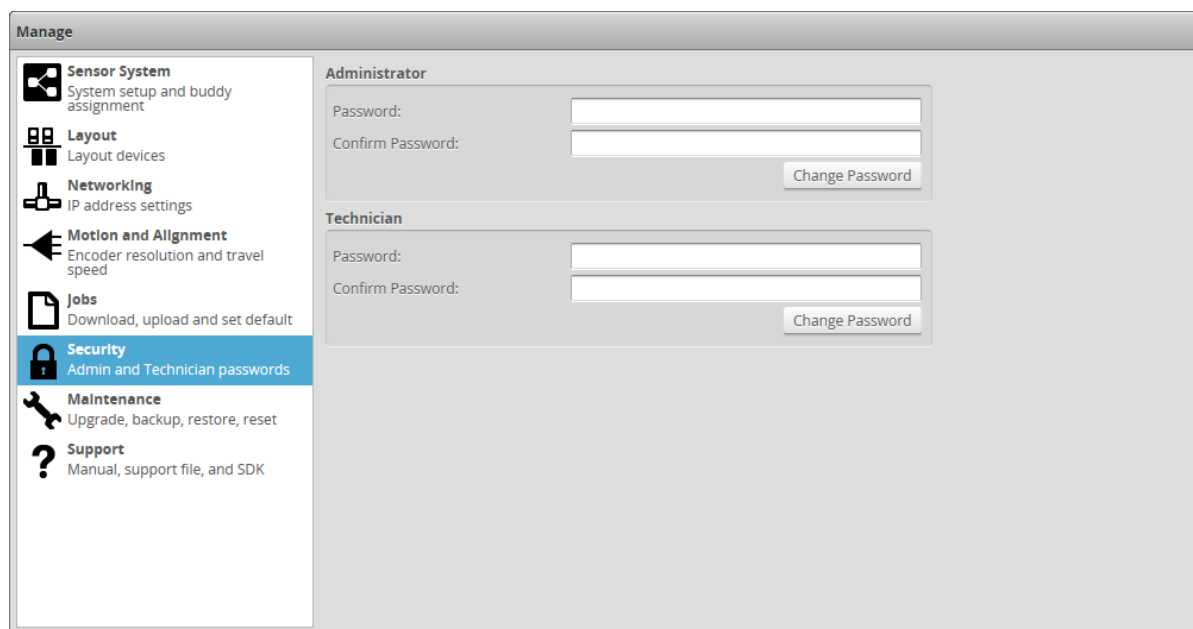

Account Types

Account	Description
Administrator	The Administrator account has privileges to use the toolbar (loading and saving jobs, recording and viewing replay data), to view all pages and edit all settings, and to perform setup procedures such as sensor alignment.
Technician	The Technician account has privileges to use the toolbar (loading and saving jobs, recording and viewing replay data), to view the Dashboard page, and to start or stop the sensor.

The Administrator and Technician accounts can be assigned unique passwords.

To set or change the password for the Administrator account:

1. Go to the **Manage** page and click on the **Security** category.
2. In the **Administrator** section, enter the Administrator account password and password confirmation.
3. Click **Change Password**.
The new password will be required the next time that an administrator logs in to the sensor.

To set or change the password for the Technician account:

1. Go to the **Manage** page and click on the **Security** category.
2. In the **Technician** section, enter the Technician account password and password confirmation.
3. Click **Change Password**.
The new password will be required the next time that a technician logs in to the sensor.

If the administrator or technician password is lost, the sensor can be recovered using a special software tool. See *Sensor Discovery Tool* on page 504 for more information.

Maintenance

The **Maintenance** category in the **Manage** page is used to do the following:

- upgrade the firmware and check for firmware updates;
- back up and restore all saved jobs and recorded data;
- restore the sensor to factory defaults;
- reset the sensor.

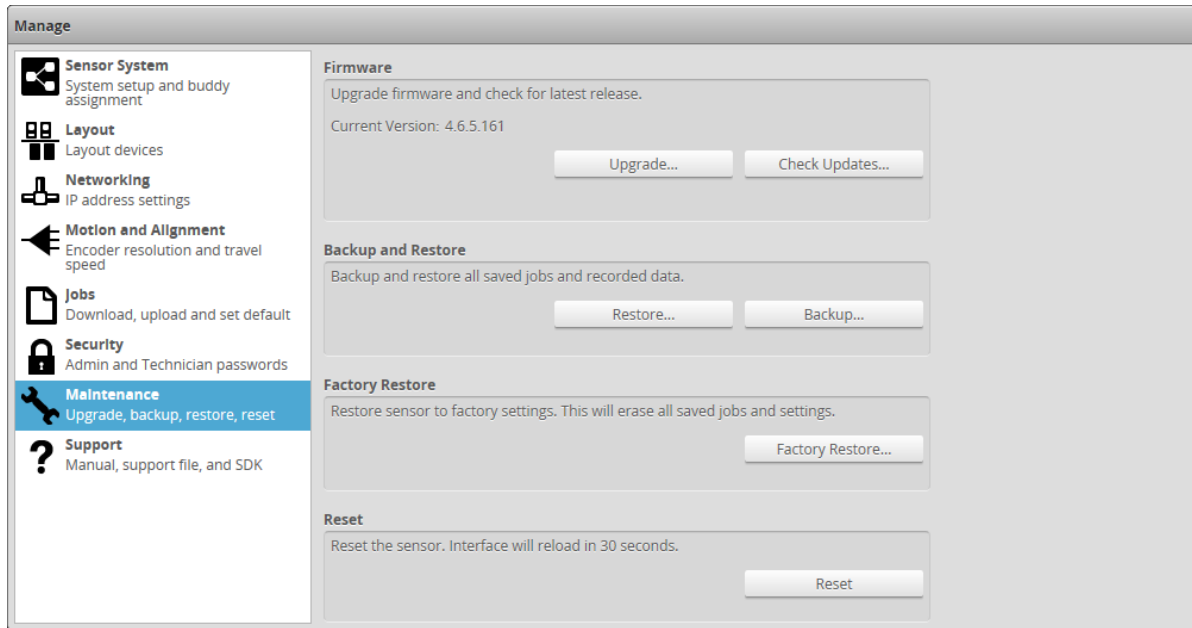

Sensor Backups and Factory Reset

You can create sensor backups, restore from a backup, and restore to factory defaults in the **Maintenance** category.

Backup files contain all of the information stored on a sensor, including jobs and alignment.

 An Administrator should create a backup file in the unlikely event that a sensor fails and a replacement sensor is needed. If this happens, the new sensor can be restored with the backup file.

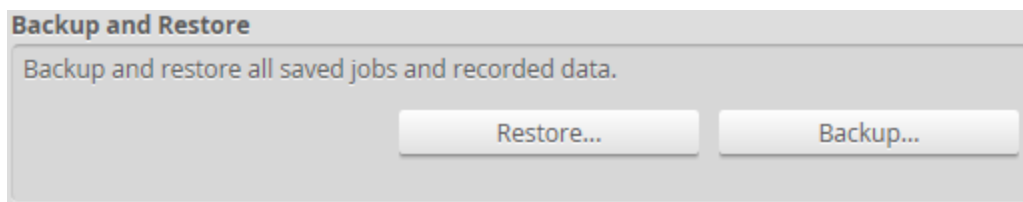

To create a backup:

1. Go to the **Manage** page and click on the **Maintenance** category.
2. Click the **Backup...** button under **Backup and Restore**.
3. When you are prompted, save the backup.
Backups are saved as a single archive that contains all of the files from the sensor.

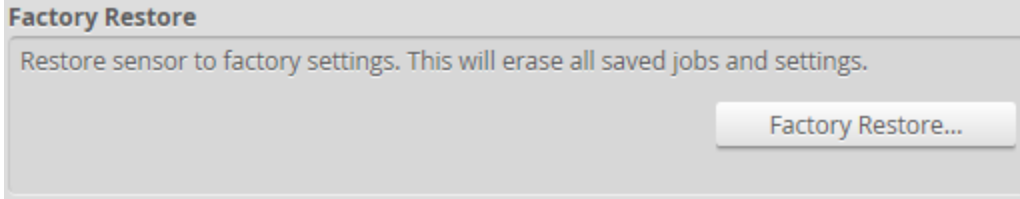

To restore from a backup:

1. Go to the **Manage** page and click on the **Maintenance** category.
2. Click the **Restore...** button under **Backup and Restore**.
3. When you are prompted, select a backup file to restore.
The backup file is uploaded and then used to restore the sensor. Any files that were on the sensor before the restore operation will be lost.

To restore a sensor to its factory default settings:

1. Go to the **Manage** page and click on **Maintenance**.
2. Consider making a backup.
Before proceeding, you should perform a backup. Restoring to factory defaults cannot be undone.
3. Click the **Factory Restore...** button under **Factory Restore**.
You will be prompted whether you want to proceed.

Firmware Upgrade

LMI recommends routinely updating firmware to ensure that sensors always have the latest features and fixes.

 In order for the Main and Buddy sensors to work together, they must be use the same firmware version. This can be achieved by upgrading through the Main sensor or by upgrading each sensor individually.

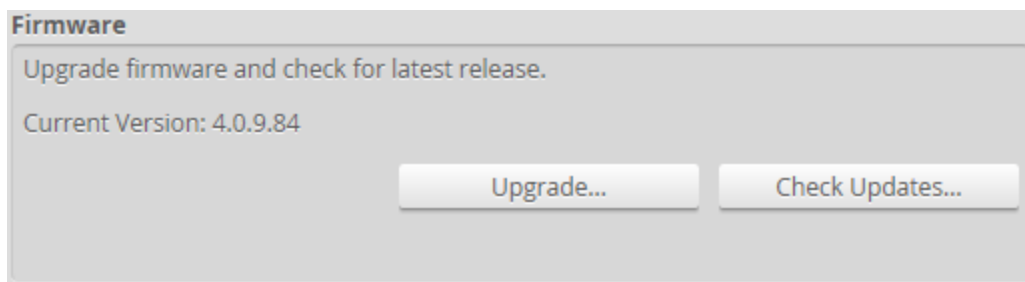

To download the latest firmware:

1. Go to the **Manage** page and click on the **Maintenance** category.
2. Click the **Check Updates...** button in the **Firmware** section.

3. Download the latest firmware.
If a new version of the firmware is available, follow the instructions to download it to the client computer.

If the client computer is not connected to the Internet, firmware can be downloaded and transferred to the client computer by using another computer to download the firmware from LMI's website:
<http://www.lmi3d.com/support/downloads>.

To upgrade the firmware:

1. Go to the **Manage** page and click on the **Maintenance** category.
2. Click the **Upgrade...** button in the **Firmware** section.
3. Locate the firmware file in the **File** dialog and then click open.
4. Wait for the upgrade to complete.
After the firmware upgrade is complete, the sensor will self-reset. If a buddy has been assigned, it will be upgraded and reset automatically.

Support

The **Support** category in the **Manage** page is used to do the following:

- Open an HTML version or download a PDF version of the manual.
- Download the SDK.
- Save a support file.
- Get device information.

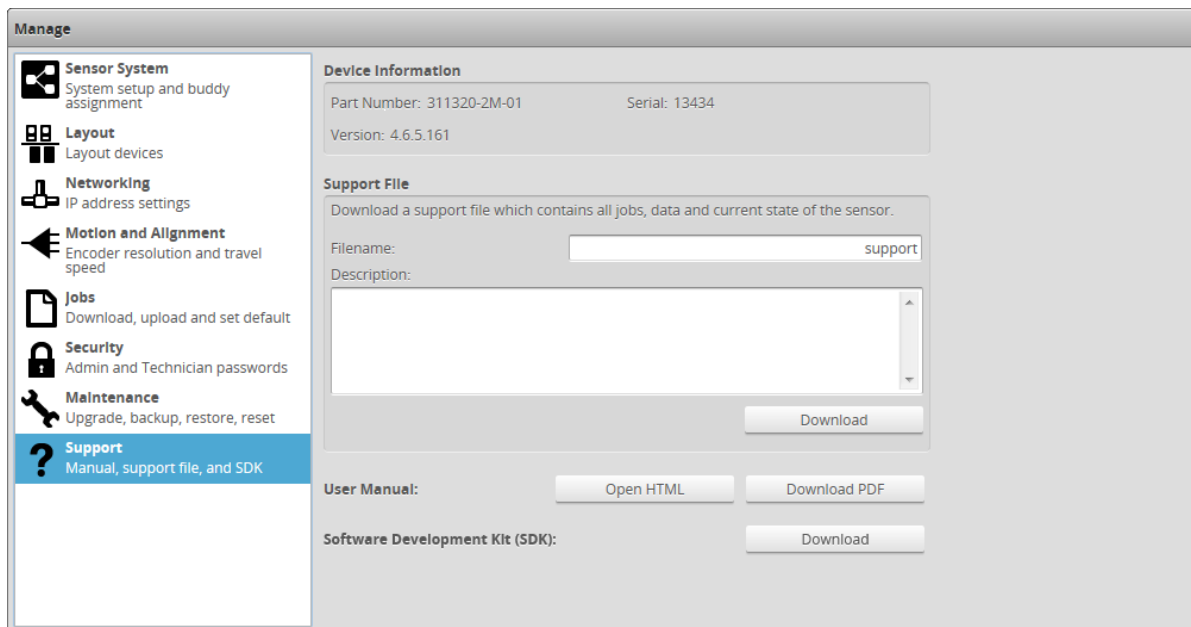

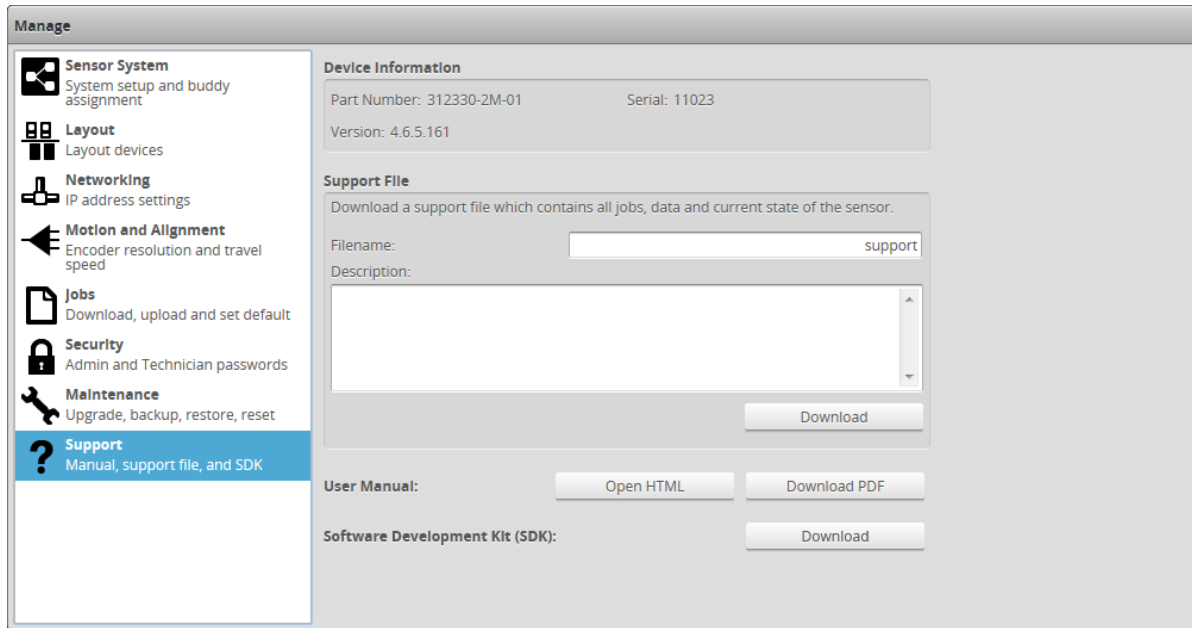

Support Files

You can download a support file from a sensor and save it on your computer. You can then use the support file to create a scenario in the emulator (for more information on the emulator, see *Gocator Emulator* on page 251). LMI's support staff may also request a support file to help in troubleshooting.

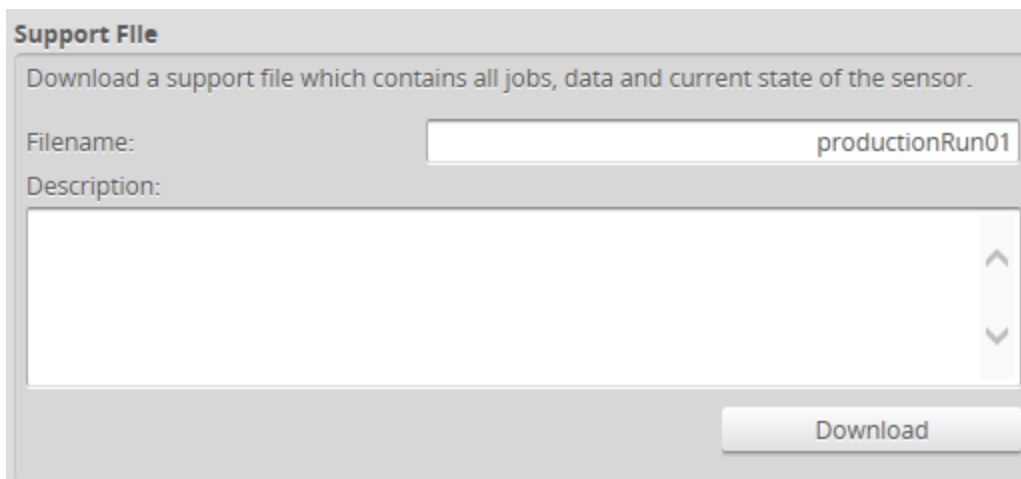

To download a support file:

1. Go to the **Manage** page and click on the **Support** category.
2. In **Filename**, type the name you want to use for the support file.
When you create a scenario from a support file in the emulator, the filename you provide here is displayed in the emulator's scenario list.
Support files end with the .gs extension, but you do not need to type the extension in **Filename**.
3. (Optional) In **Description**, type a description of the support file.

When you create a scenario from a support file in the emulator, the description is displayed below the emulator's scenario list.

4. Click **Download**, and then when prompted, click **Save**.

 Downloading a support file stops the sensor.

Manual Access

You can access the Gocator manuals from within the Web interface.

User Manual:

 You may need to configure your browser to allow pop-ups to open or download the manual.

To access the manuals:

1. Go to the **Manage** page and click on the **Support** category
2. Next to **User Manual**, click one of the following:
 - **Open HTML**: Opens the HTML version of the manual in your default browser.
 - **Download PDF**: Downloads the PDF version of the manual to the client computer.

Software Development Kit

You can download the Gocator SDK from within the Web interface.

Software Development Kit (SDK):

To download the SDK:

1. Go to the **Manage** page and click on the **Support** category
2. Next to **Software Development Kit (SDK)**, click **Download**
3. Choose the location for the SDK on the client computer.

 For more information on the SDK, see *Development Kits* on page 480.

Scan Setup and Alignment

The following sections describe the steps to configure sensors for data acquisition using the **Scan** page. Setup and alignment should be performed before adding and configuring measurements or outputs.

Scan Page Overview

The **Scan** page lets you configure sensors and perform alignment.

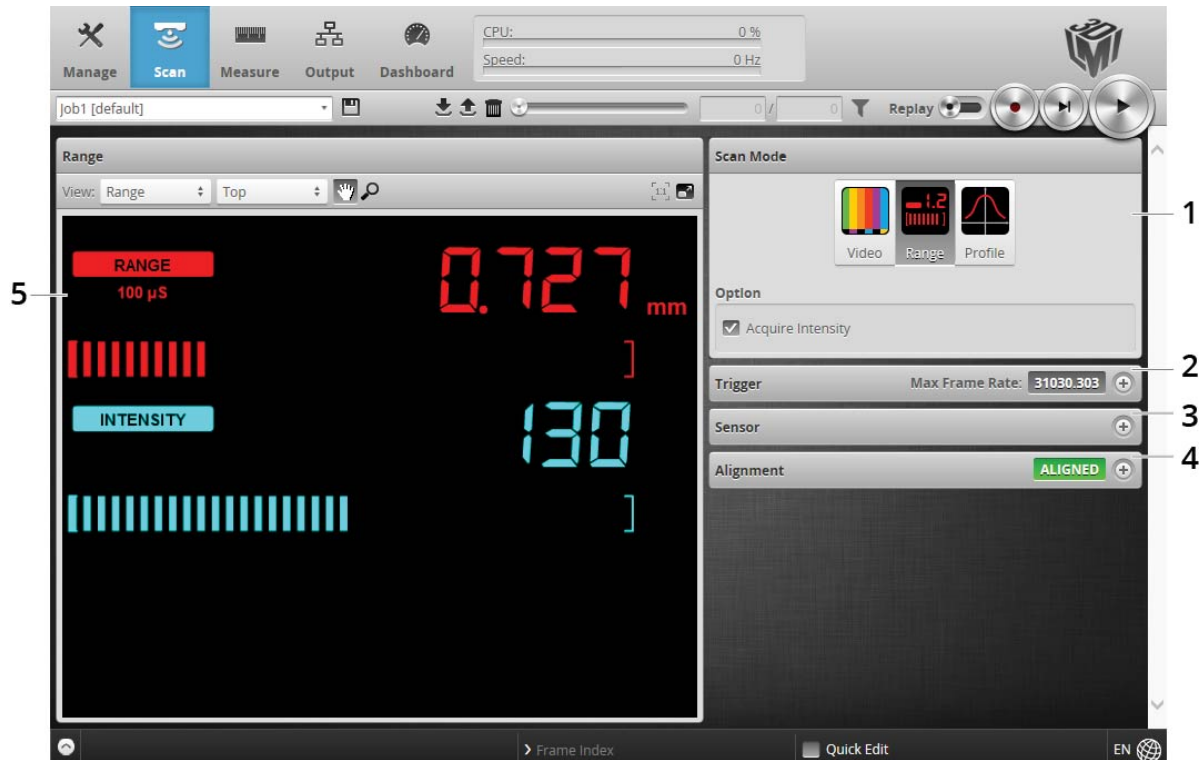

Element	Description	
1	Scan Mode panel	Contains settings for the current scan mode and other options. See <i>Scan Modes</i> on the next page.
2	Trigger panel	Contains trigger source and trigger-related settings. See <i>Triggers</i> on the next page.
3	Sensor panel	Contains settings for an individual sensor, such as active area or exposure. See <i>Sensor</i> on page 98.
4	Alignment panel	Used to perform alignment. See <i>Alignment</i> on page 106.
5	Data Viewer	Displays sensor data and adjusts regions of interest. Depending on the current operation mode, the data viewer can display video images or scan data. See <i>Data Viewer</i> on page 120.

The following table provides quick references for specific goals that you can achieve from the panels in the **Scan** page.

Goal	Reference
Select a trigger source that is appropriate for the application.	Triggers (page 91)
Ensure that camera exposure is appropriate for scan data acquisition.	Exposure (page 101)
Find the right balance between data quality, speed, and CPU utilization.	Active Area (page 98) Exposure (page 101) Job File Structure (page 273)
Align scan data to a common reference and so that values can be correctly scaled along the different axes.	Aligning Sensors (page 107)

Scan Modes

The sensor web interface supports a video mode and one or more data acquisition modes. The scan mode can be selected in the **Scan Mode** panel.

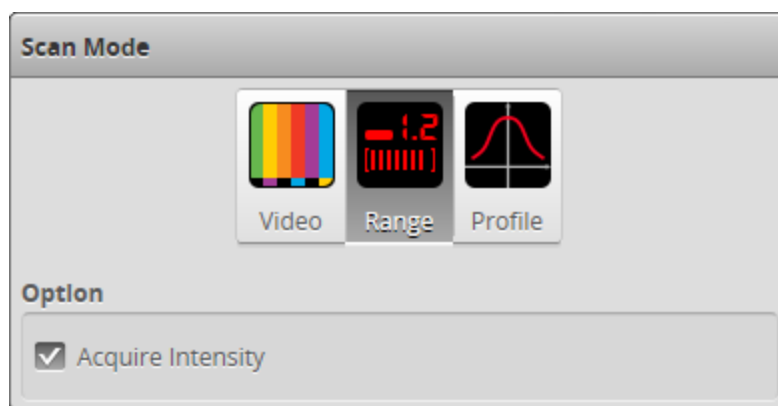

Mode and Option	Description
Video	Outputs video images from the sensor. This mode is useful for configuring exposure time and troubleshooting stray light or ambient light problems.
Range	Outputs ranges and performs measurements. Video images are processed internally to produce laser ranges and measurements.
Profile	Outputs profiles and performs profile measurements. The sensor uses various methods to generate a profile (see <i>Profile Generation</i> on page 115). Part detection can be enabled on a profile to identify discrete parts (see <i>Part Detection</i> on page 118). Video images are processed internally to produce laser profiles and cross-sectional measurements.
Acquire Intensity	When this option is enabled, an intensity value will be produced for each data point.

Triggers

A trigger is an event that causes a sensor to take a single image. Triggers are configured in the **Trigger** panel on the **Scan** page.

When a trigger is processed, the laser is strobed and the camera exposes to produce an image. The resulting image is processed inside the sensor to yield a laser range (distance information). The data can

then be used for measurement.

The sensor can be triggered by one of the sources described in the table below.

 If the sensor is connected to a Master 400 or higher, encoder and digital (external) input signals over the IO cordset are *ignored*. The sensor instead receives these signals from the Master; for encoder and digital input pinouts on Masters, see the section corresponding to your Master in *Master Network Controllers* on page 546.

If the sensor is connected to a [Master 100](#) (or no Master is used), the sensor receives signals over the IO cordset. For information on connecting encoder and digital input signals to a sensor in these cases, see *Encoder Input* on page 543 and *Digital Input* on page 542, respectively.

Trigger Source	Description
Time	Sensors have an internal clock that can be used to generate fixed-frequency triggers. The external input can be used to enable or disable the time triggers.

Trigger Source**Description**

Encoder

An encoder can be connected to provide triggers in response to motion. Three encoder triggering behaviors are supported. These behaviors are set using the **Behavior** setting.

Track Backward

A scan is triggered when the target object moves forward. If the target object moves backward, it must move forward by at least the distance that the target travelled backward (this distance backward is "tracked"), plus one encoder spacing, to trigger the next scan.

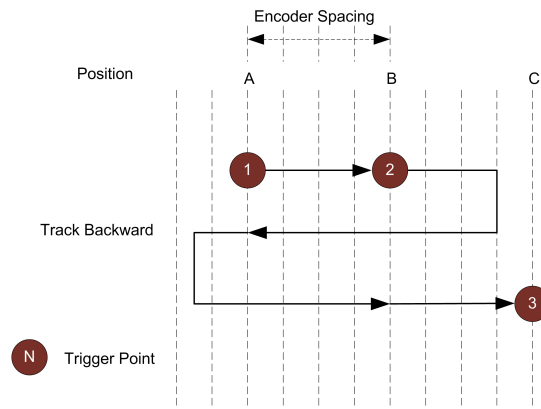
**Ignore Backward**

A scan is triggered only when the target object moves forward. If the target object moves backward, it must move forward by at least the distance of one encoder spacing to trigger the next scan.

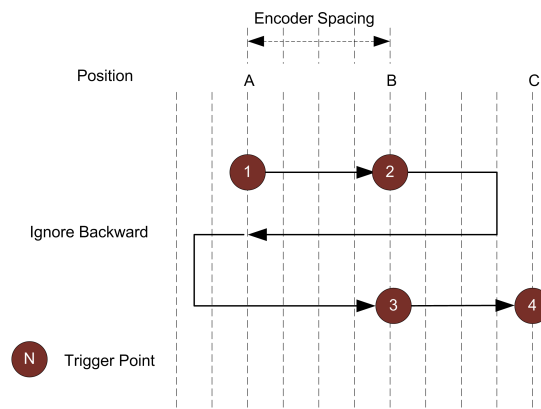
**Bi-directional**

A scan is triggered when the target object moves forward or backward.

Trigger Source	Description
----------------	-------------

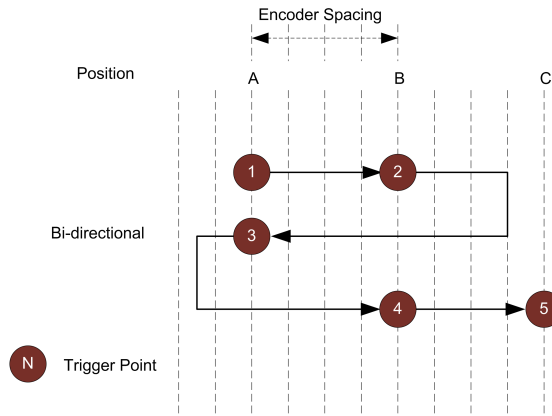

When triggers are received at a frequency higher than the maximum frame rate, some triggers may not be accepted. The **Trigger Drops Indicator** in the **Dashboard** can be used to check for this condition.

The external input can be used to enable or disable the encoder triggers.

For information on the maximum encoder rate, see *Maximum Encoder Rate* on page 98.

 To verify that the sensor is receiving encoder signals, check whether **Encoder Value** is changing in the [Motion and Alignment](#) category on the **Manage** page, or in the [dashboard](#).

External Input	<p>A digital input can provide triggers in response to external events (e.g., photocell). The external input triggers on the rising edge of the signal.</p> <p>When triggers are received at a frequency higher than the maximum frame rate, some triggers may not be accepted. The Trigger Drops Indicator in the Dashboard page can be used to check for this condition.</p> <p>For information on the maximum input trigger rate, see <i>Maximum Input Trigger Rate</i> on page 98.</p>
----------------	--

Software	<p>A network command can be used to send a software trigger. See <i>Protocols</i> on page 342 for more information.</p>
----------	---

Depending on the setup and measurement tools used, the CPU utilization may exceed 100%, which reduces the overall acquisition speed.

For examples of typical real-world scenarios, see *Trigger Examples* on the next page. For information on the settings used with each trigger source, see *Trigger Settings* on page 96.

Trigger Examples

Example: Encoder + Conveyor

Encoder triggering is used to perform range measurements at a uniform spacing.

The speed of the conveyor can vary while the object is being measured; an encoder ensures that the trigger spacing is consistent, independent of conveyor speed.

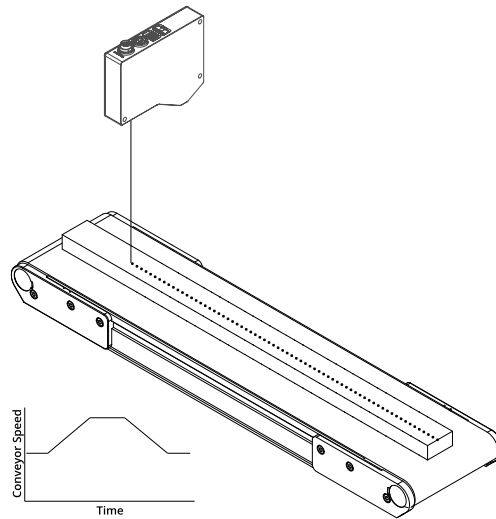

Example: Time + Conveyor

Time triggering can be used instead of encoder triggering to perform range measurements at a fixed frequency.

Spacing will be non-uniform if the speed of the conveyor varies while the object is being measured.

It is strongly recommended to use an encoder with transport-based systems due to the difficulty in maintaining constant transport velocity.

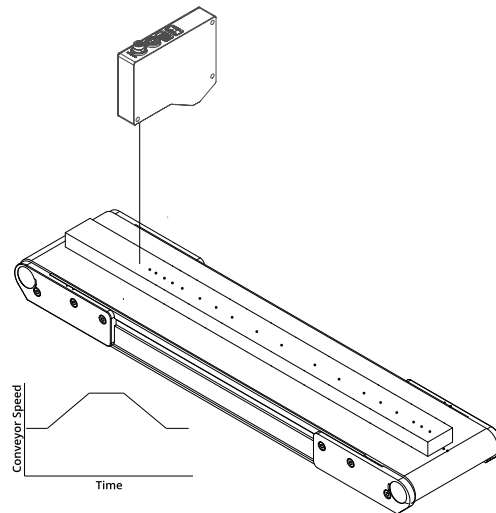

Example: External Input + Conveyor

External input triggering can be used to produce a snapshot for range measurement.

For example, a photocell can be connected as an external input to generate a trigger pulse when a target object has moved into position.

An external input can also be used to gate the trigger signals when time or encoder triggering is used. For example, a photocell could generate a series of trigger pulses as long as there is a target in position.

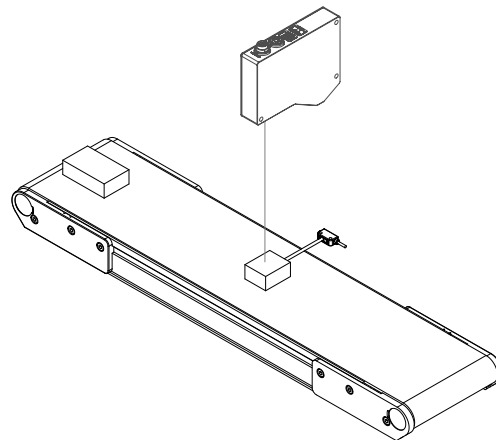

Example: Software Trigger + Robot Arm

Software triggering can be used to produce a snapshot for range measurement.

A software trigger can be used in systems that use external software to control the activities of system components.

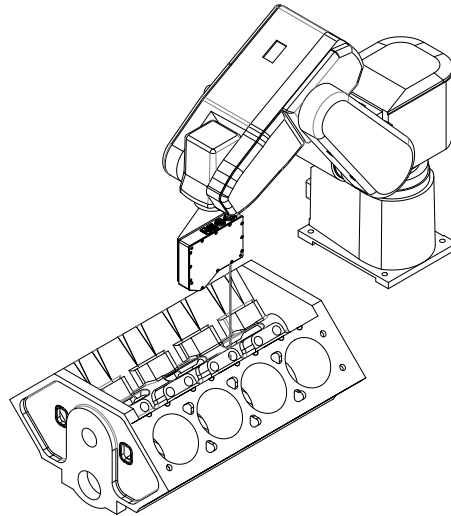

Trigger Settings

The trigger source is selected using the **Trigger** panel in the **Scan** page.

Trigger Max Frame Rate: 31030.303

Source: Time

Frame Rate: Max Speed Hz

Gate on External Input

Trigger Max Frame Rate: 31030.303

Source: Encoder

Spacing: 1 mm

Behavior: Bi-Directional

Gate on External Input

Trigger Max Frame Rate: 31030.303

Source: External Input

Units: μ s (Time)

Trigger Delay: 0 μ s

Trigger Max Frame Rate: 31030.303

Source: Software

Units: μ s (Time)

Gate on External Input

After specifying a trigger source, the **Trigger** panel shows the parameters that can be configured.

Gocator 1300 series sensors are limited to sending data at 10 kHz over the analog output channel. Therefore, if you configure a sensor so that it runs at a speed higher than 10 kHz in the **Trigger** panel on the **Scan** page, and configure a measurement to be sent on the analog channel under **Analog** on the **Output** page, you will get analog data drops.

To achieve a 10 kHz analog output rate, you must check **Scheduled** on the **Output** page and configure scheduled output.

Parameter	Trigger Source	Description
Source	All	Selects the trigger source (Time , Encoder , External Input , or Software).
Frame Rate	Time	Controls the frame rate. Select Max Speed from the drop-down to lock to the maximum frame rate. Fractional values are supported. For example, 0.1 can be entered to run at 1 frame every 10 seconds.
Gate on External Input	Time, Encoder	External input can be used to enable or disable data acquisition in a sensor. When this option is enabled, the sensor will respond to time or encoder triggers only when the external input is asserted. See <i>Digital Input</i> on page 542 for more information on connecting external input to sensors.
Behavior	Encoder	Specifies how the sensor is triggered when the target moves. Can be Track Backward, Ignore Backward, or Bi-Directional. See <i>Triggers</i> on page 91 for more information on these behaviors.
Spacing	Encoder, External Input	Specifies the distance between triggers (mm). Internally the sensor rounds the spacing to a multiple of the encoder resolution.
Reversal Distance	Encoder	When encoder triggering is set to Bi-Directional , use this setting to ignore jitter or vibrations in your transport system by specifying what distance the target must travel before a direction change is triggered. One of the following: Auto: The distance is automatically set by multiplying the value in Spacing by 3. Custom: Set the distance (in millimeters). Various functions in the sensor depend on this value to explicitly determine the point where direction change is triggered. Set this value larger than the maximum vibrations you see in your transport system.
Units	External Input, Software	Specifies whether the trigger delay, output delay, and output scheduled command operate in the time or the encoder domain. The unit is implicitly set to microseconds with Time trigger source. The unit is implicitly set to millimeters with Encoder trigger source.
Trigger Delay	External Input	Controls the amount of time or the distance the sensor waits before producing a frame after the external input is activated. This is used to compensate for the positional difference between the source of the external input trigger (e.g., photocells) and the sensor. Trigger delay is only supported in single exposure mode; for details, see <i>Exposure</i> on page 101.

To configure the trigger source:

1. Go to the **Scan** page.
2. Expand the **Trigger** panel by clicking on the panel header.
3. Select the trigger source from the drop-down.
4. Configure the settings.
See the trigger parameters above for more information.
5. Save the job in the **Toolbar** by clicking the **Save** button .

Maximum Input Trigger Rate



The maximum external input trigger rate in a system including Master 400 or higher is 20 kHz.

When using a standalone sensor or a sensor connected to a Master 100, the maximum trigger rate is 32 kHz. This rate is limited by the fall time of the signal, which depends on the V_{in} and duty cycles. To achieve the maximum trigger rate, the V_{in} and duty cycles must be adjusted as follows:

Maximum Speed	V_{in}	Maximum Duty Cycle
32 kHz	3.3 V	88%
32 kHz	5 V	56%
32 kHz	7 V	44%
32 kHz	10 V	34%

At 50% duty cycle, the maximum trigger rates are as follows:

V_{in}	Maximum Speed
3.3 V	34 kHz
5 V	34 kHz
10 V	22 kHz

Maximum Encoder Rate

On a standalone sensor, with the encoder directly wired into the I/O port or through a Master 100, the maximum encoder rate is about 1 MHz.

For sensors connected through a Master 400 or higher, with the encoder signal supplied to the Master, the maximum rate is about 300 kHz.

Sensor

The following sections describe the settings that are configured in the **Sensor** panel on the **Scan** page.

Active Area

Active area refers to the region within the sensor's maximum field of view that is used for data acquisition.

By default, the active area covers the sensor's entire field of view. By reducing the active area, the sensor can operate at higher speeds. You can also reduce the active area to exclude areas that are affected by ambient light.

Active area is specified in sensor coordinates, rather than in system coordinates. As a result, if the sensor is already alignment calibrated, press the **Acquire** button to display uncalibrated data before configuring the active area. See *Coordinate Systems* on page 54 for more information on sensor and system coordinates.

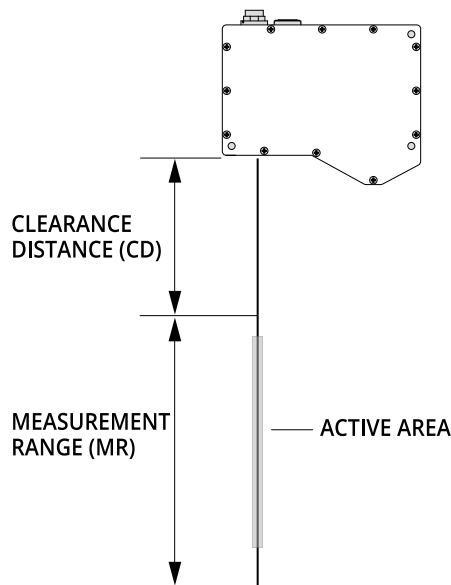

Active area is set in the **Active Area** tab on the **Sensor** panel.

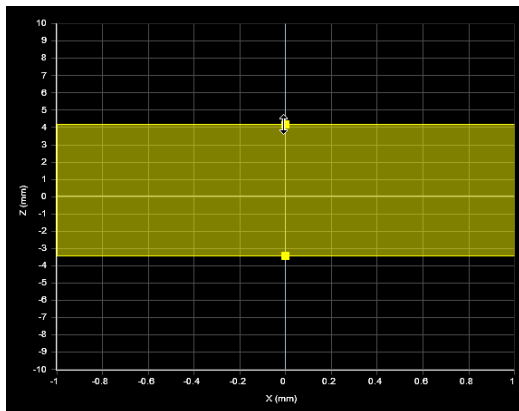

To set the active area:

1. Go to the **Scan** page.
2. Choose a mode other than Video mode.
3. Expand the **Sensor** panel by clicking on the panel header or the **+** button.

4. Click the button corresponding to the sensor you want to configure.
The button is labeled **Top**, **Bottom**, **Top-Left**, or **Top-Right**, depending on the system.
Active area is specified separately for each sensor.
5. Click on the **Active Area** tab.
6. Click **Select**.
7. Click **Acquire** to see a scan while setting the active area.
Acquiring a scan while setting the active area can help you determine where to size and place the active area.
8. Set the active area.
Adjust the active area graphically in the data viewer or enter the values manually in the fields.
9. Click the **Save** button in the **Sensor** panel.
Click the **Cancel** button to cancel setting the active area.
10. Save the job in the **Toolbar** by clicking the **Save** button .

Transformations

The transformation settings determine how data is converted from sensor coordinates to system coordinates (for an overview on coordinate systems, see *Coordinate Systems* on page 54). Typically, transformations are set when you [align a sensor](#). However, you can also manually set values using the **Transformations** section of the **Active Area** tab on the [Sensor](#) panel.



Parameter	Description
Z Offset	Specifies the shift along the Z axis. A positive value shifts the data toward the sensor.
Angle	Specifies the tilt (rotation in the X-Z plane). A positive value rotates the profile counter-clockwise.

When applying the transformations, angular rotation is applied before the Z offset.

To configure transformation settings:

1. Go to the **Scan** page.
2. Choose a mode other than Video mode in the **Scan Mode** panel.
If Video mode is selected, you will not be able to change the settings.
3. Expand the **Sensor** panel by clicking on the panel header.
4. Click the button corresponding to the sensor you want to configure.

The button is labeled **Top**, **Bottom**, **Top-Left**, or **Top-Right**, depending on the system. Transformations can be configured separately for each sensor.

5. Expand the Transformations area by clicking on the expand button ☰.
See the table above for more information.
6. Set the parameter values.
See the table above for more information.
7. Save the job in the **Toolbar** by clicking the **Save** button 📁.
8. Check that the transformation settings are applied correctly after the sensor is restarted.

Exposure

Exposure determines the duration of camera and light-source on-time. Longer exposures can be helpful to detect light on dark or distant surfaces, but increasing exposure time decreases the maximum speed. Different target surfaces may require different exposures for optimal results. Sensors provide two exposure modes for the flexibility needed to scan different types of target surfaces.

Exposure Mode	Description
Single	Uses a single exposure for all objects. Used when the surface is uniform and is the same for all targets.
Dynamic	Automatically adjusts the exposure after each frame. Used when the target surface varies between scans.

For more information on the different types of exposure options, see the sections below.

Video mode lets you see how the light appears on the camera and identify any stray light or ambient light problems. When exposure is tuned correctly, the projected light should be clearly visible along the entire length of the viewer. If it is too dim, increase the exposure value; if it is too bright decrease exposure value.

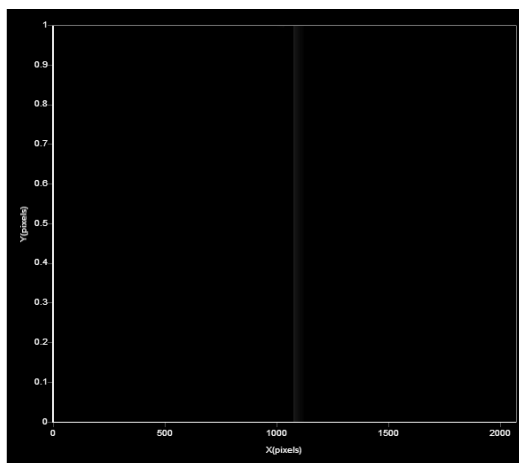

*Under-exposure:
Laser point is not detected.
Increase the exposure value.*

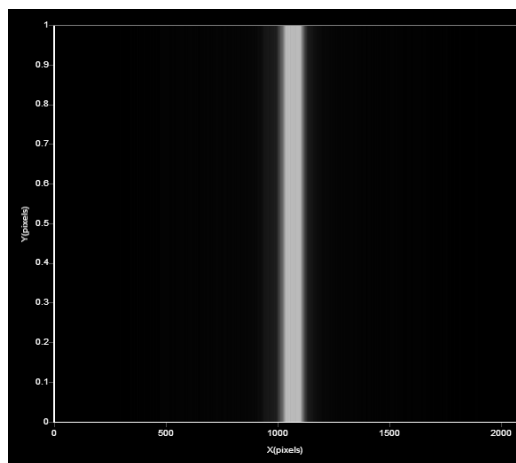

*Over-exposure:
Laser point is too bright.
Decrease the exposure value.*

Single Exposure

The sensor uses a fixed exposure in every scan. Single exposure is used when the target surface is uniform and is the same for all targets.

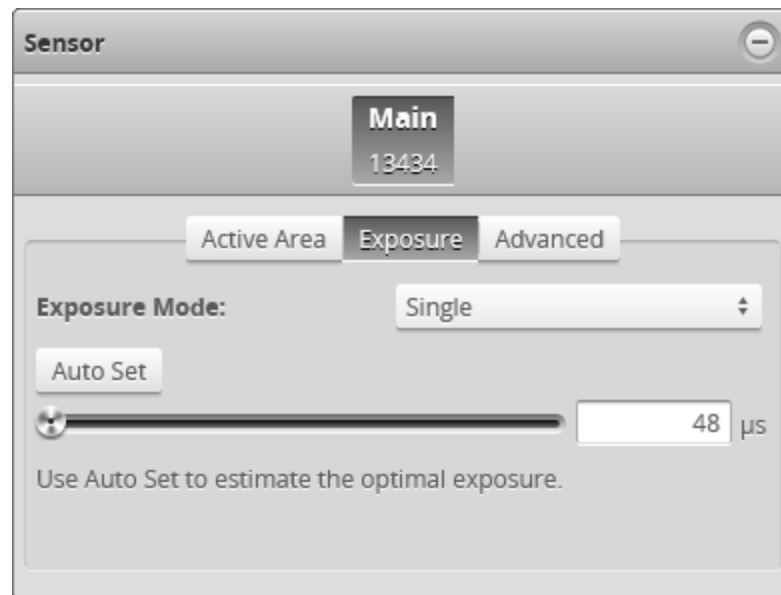

To enable single exposure:

1. Place a representative target in view of the sensor.
The target surface should be similar to the material that will normally be measured.
2. Go to the **Scan** page.
3. Expand the **Sensor** panel by clicking on the panel header or the  button.
4. Click the button corresponding to the sensor you want to configure.
The button is labeled **Top**, **Bottom**, **Top-Left**, or **Top-Right**, depending on the system.
Exposure is configured separately for each sensor.
5. Click the **Exposure** tab.
6. Select **Single** from the **Exposure Mode** drop-down.
7. Edit the exposure setting by using the slider or by manually entering a value.
You can automatically tune the exposure by pressing the **Auto Set** button, which causes the sensor to turn on and tune the exposure time.
8. Run the sensor and check that laser ranging is satisfactory.

Dynamic Exposure

The sensor automatically uses past range information to adjust the exposure for subsequent exposures to yield the best range. This is used when the target surface changes from exposure to exposure (that is, from scan to scan).



You can tune settings that control the exposure that is chosen by dynamic exposure in the [Material](#) tab.

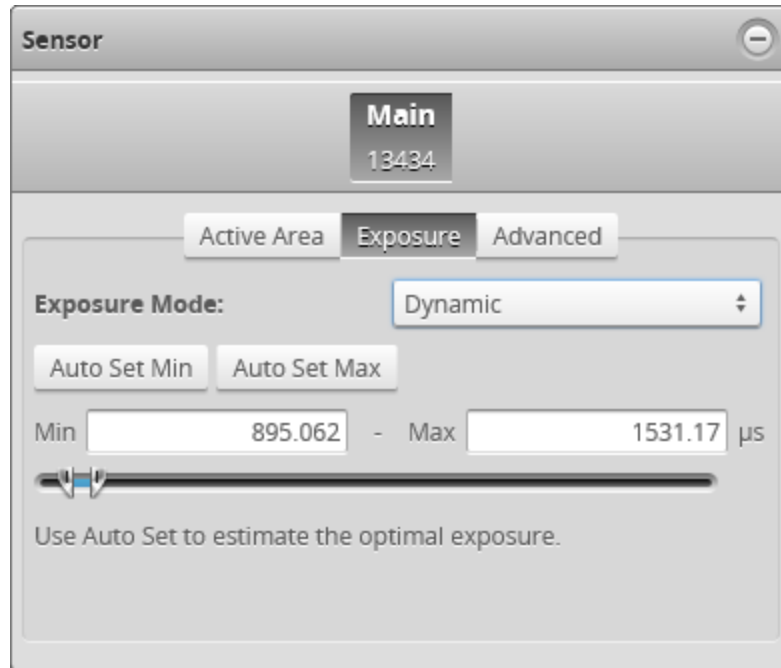

To enable dynamic exposure:



1. Go to the **Scan** page.
2. Expand the **Sensor** panel by clicking on the panel header or the \oplus button.
3. Click the button corresponding to the sensor you want to configure.
The button is labeled **Top**, **Bottom**, **Top-Left**, or **Top-Right**, depending on the system.
Exposure is configured separately for each sensor.
4. Click the **Exposure** tab.
5. Select **Dynamic** from the **Exposure Mode** drop-down.
6. Set the minimum and maximum exposure.
The auto-set function can be used to automatically set the exposure. First, place the brightest target in the field of view and press the **Auto Set Min** button to set the minimum exposure. Then, place the darkest target in the field of view and press the **Auto Set Max** button to set the maximum exposure.
7. Run the sensor and check that laser ranging is satisfactory.
If laser ranging is not satisfactory, adjust the exposure values manually. Switch to **Video** mode to use video to help tune the exposure; see *Exposure* on page 101 for details.

Advanced

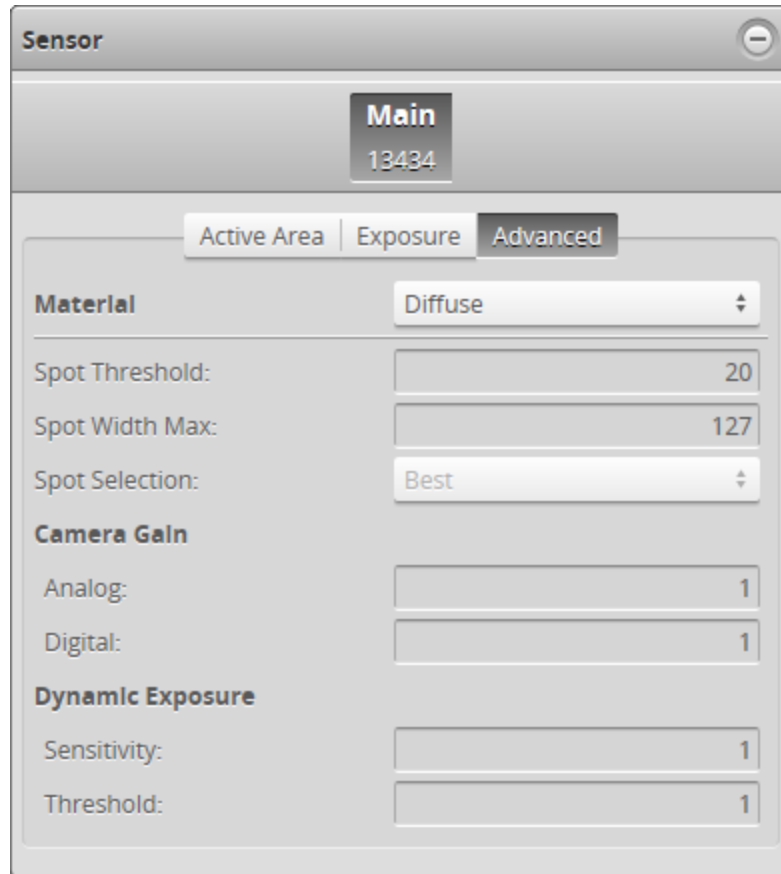
The **Advanced** tab contains settings to configure material characteristics, camera gain, and dynamic exposure.



To configure advanced settings:

1. Go to the **Scan** page.
2. Switch to Video mode.
Using Video mode while configuring the settings lets you evaluate their impact.
3. Expand the **Sensor** panel by clicking on the panel header or the  button.
4. If you are configuring a dual- or multi-sensor system, click the button corresponding to the sensor you want to configure.
The button is labeled **Top**, **Bottom**, **Top-Left**, or **Top-Right**, depending on the system.
Settings can be configured separately for each sensor.
5. Click on the **Advanced** tab.
6. Configure material characteristics, camera gain, or dynamic exposure.
For more information, see *Material* on the next page and *Material Settings and Dynamic Exposure* on the next page.
7. Save the job in the **Toolbar** by clicking the **Save** button .
8. Check that scan data is satisfactory.

Material

Data acquisition can be configured to suit different types of target materials. For many targets, changing the setting is not necessary, but it can make a great difference with others.

You can select preset material types in the **Materials** setting under the **Advanced** tab. The **Diffuse** material option is suitable for most materials.

When **Materials** is set to **Custom**, the following settings can be configured:

Setting	Description
Spot Threshold	<p>The minimum increase in intensity level between neighbouring pixels for a pixel to be considered the start of a potential spot.</p> <p>This setting is important for filtering false spots generated by sunlight reflection.</p>
Spot Width Max	<p>The maximum number of pixels a spot is allowed to span.</p> <p>This setting can be used to filter out data caused by background light if the unwanted light is wider than the laser and does not merge into the laser itself. A lower Spot Width Max setting reduces the chance of false detection, but limits the ability to detect features/surfaces that elongate the spot.</p>
Spot Selection	<p>Determines the spot selection method.</p> <p>Best selects the strongest spot in a given column on the imager.</p> <p>Top or Bottom: Top selects the spot farthest to the left on the imager, and Bottom selects the spot farthest to the right on the imager. These options can be useful in applications where there are reflections, flying sparks or smoke that are always on one side of the laser.</p> <p>None performs no spot filtering. If multiple spots are detected in an imager column, they are left as is. .</p> <p>Note that when Uniform Spacing is disabled and Spot Selection is set to None, both Profile Dimension and Profile Position are unavailable; for more information on enabling and disabling uniform spacing, see <i>Scan Modes</i> on page 91.</p> <p>Continuity considers adjacent horizontal data points on the imager to place spots on pixels, giving preference to more complete profile segments. The setting can improve scans in the presence of reflections and noise.</p>

Various settings can affect how the **Material** settings behave. See *Spots and Dropouts* on page 121 for more information.

Material Settings and Dynamic Exposure

You can set camera gain and dynamic exposure to improve data acquisition.

Setting	Description
Camera Gain	<p>Analog camera gain can be used when the application is severely exposure limited, yet dynamic range is not a critical factor.</p> <p>Digital camera gain can be used when the application is severely exposure limited, yet</p>

Setting	Description
Dynamic Exposure	dynamic range is not a critical factor.
	<p>Sensitivity controls the exposure that dynamic exposure converges to. The lower the value, the lower the exposure the sensor will settle on.</p> <p>The trade-off is between the number of underexposed spots and the possibility of over-exposing.</p> <p>Threshold is the minimum number of spots for dynamic exposure to consider the profile point that make up the spot valid. If the number of spots is below this threshold, the algorithm will walk over the allowed exposure range slowly to find the correct exposure. Because this is slow, the Threshold value typically should be kept as low as possible, so this slow search is not used.</p> <p>These settings let you set tune how dynamic exposure settles on an exposure for a scan. For more information on Dynamic Exposure, see <i>Dynamic Exposure</i> on page 102.</p>

Alignment

Alignment procedures are required to compensate for sensor mounting inaccuracies or to set a Z (height) reference plane. The alignment procedure also sets a common coordinate system for multi-sensor systems, and determines the encoder resolution (if present) and the speed of the transport system. (In many systems, the reference surface is a conveyor belt.)



Sensors are pre-calibrated and ready to deliver data in engineering units (mm) out of the box. Alignment procedures do not affect sensor calibration.

A sensor can be in one of two alignment states: Unaligned and Aligned. An indicator on the **Alignment** panel display UNALIGNED or ALIGNED, depending on the sensor's state.

Alignment State

State	Explanation
Unaligned	The sensor or sensor system is not aligned. Data points are reported in sensor coordinates.
Aligned	The sensor is aligned using the alignment procedure (described below) or by manually modifying the values under Transformation in the Sensor tab on the Scan page (for more information, see <i>Transformations</i> on page 100). Data points are reported in system coordinates.

Once the alignment procedure has completed, the derived transformation values are displayed under **Transformations** in the **Sensor** panel.

Alignment Types

Sensors support two types of alignment: stationary or moving.

Type	Description
Stationary	Stationary is used when the alignment target does not move.
Moving	Moving is used when the alignment target moves beneath the sensor.

Aligning Sensors

Alignment is configured and performed using the **Alignment** panel.

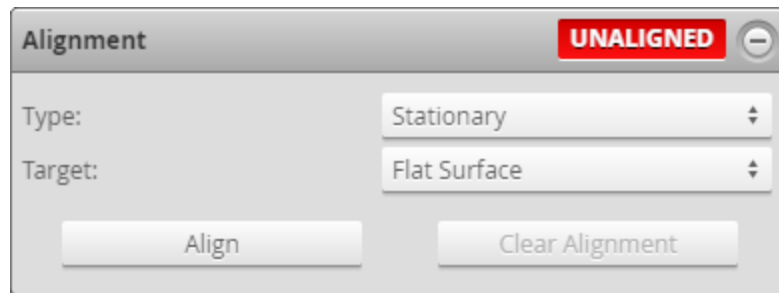

To prepare for alignment:

1. Choose an alignment reference in the **Manage** page if you have not already done so. For more information, see *Alignment Reference* on page 80.
2. Go to the **Scan** page.
3. Choose a mode other than Video mode in the **Scan Mode** panel.
4. Expand the **Alignment** panel by clicking on the panel header or the \oplus button.
5. Ensure that all sensors have a clear view of the target surface. Remove any irregular objects from the sensor's field of view that might interfere with alignment.

To perform stationary alignment:

1. In the **Alignment** panel, select **Stationary** as the **Type**.
2. Clear the previous alignment if present. Press the **Clear Alignment** button to remove an existing alignment.
3. Select an alignment **Target**.
 - **Flat Surface:** Use this to align to a surface such as a conveyor.
 - **Bar:** Use this to align to a custom calibration bar.

Configure the characteristics of the target (bar dimensions and reference hole layout). For details on alignment targets, see *Alignment Targets* on page 25.



Degrees of Freedom: In stationary bar alignment, only one option is provided, namely, **X, Z, Y Angle**. This setting aligns X and Z offsets, as well as rotation around the Y axis.

Height: The thickness of the bar in the Z direction. The alignment is performed to determine the average Z height of the bar's top surface. This height value is used to offset the coordinate system so that the bottom of the calibration bar becomes the Z origin.

Width: The width of the bar in the Y direction.

4. Click the **Align** button.
The sensors will start, and the alignment process will take place. Alignment is performed simultaneously for all sensors. If the sensors do not align, check and adjust the exposure settings (page 101).

 Alignment uses the exposure defined for single exposure mode, regardless of the current exposure mode.





5. Inspect alignment results.
Data points from all sensors should now be aligned to the alignment target surface. The base of the alignment target (or target surface) provides the origin for the system Z axis.

To perform moving alignment:

1. Do one of the following if you have not already done so.
 - If the system uses an encoder, configure encoder resolution. See *Encoder Resolution* on page 80 for more information.
 - If the system does not use an encoder, configure travel speed. See *Travel Speed* on page 81 for more information.
2. In the **Alignment** panel, select **Moving** as the **Type**.
3. Clear the previous alignment if present.
Press the **Clear Alignment** button to remove an existing alignment.
4. Select an alignment **Target**.
 - Select one of the disk **Disk** options to use a disk as the alignment reference.
 - Select **Bar** to use a custom calibration bar.

Configure the characteristics of the target (bar dimensions and reference hole layout); for details on alignment bars, see *Alignment Targets* on page 25.

Degrees of Freedom: In moving bar alignment, three options are available, which are combinations of different types of alignments. X, Y, and Z compensate for offsets on the X, Y, and Z axes, respectively. Y Angle and Z Angle compensate for rotation around the Y and Z axes, respectively. Compensating for X angle rotation is currently only possible by manually setting the rotation in the [Transformations](#) panel.

-  The Y offset, X angle, and Z angle [transformations](#) cannot be non-zero when [Uniform Spacing](#) is unchecked. Therefore, when aligning a sensor using a bar alignment target with **Uniform Spacing** unchecked, set the **Degrees of Freedom** setting to **X, Z, Y Angle**, which prevents these transformations from being non-zero.
-  On sensors aligned using Z angle or X angle, and to a lesser extent Y offset, CPU usage increases when scanning, which reduces the maximum scan speed.
-  Artifacts may appear in scan data on sensors aligned using Z angle or X angle if [encoder trigger spacing](#) is set too high (resulting in a low sampling rate).
-  When aligning using **X, Y, Z, Y Angle** or **X, Y, Z, Y Angle, Z Angle**, you can improve alignment accuracy by reducing the motion speed of the target. Repeat alignment at lower speeds and observe the transformation values in the **Sensor** panel to achieve maximum accuracy.

5. Place the target under the sensor.
6. (Optional) Check the **Encoder or Speed Calibration** checkbox.
7. Click the **Align** button.
The sensors will start and then wait for the calibration target to pass through the laser plane. Alignment is performed simultaneously for all sensors. If the sensors do not align, check and adjust the [exposure settings](#).

-  Alignment uses the exposure defined for single exposure mode, regardless of the current exposure mode.

8. Engage the transport system.
When the calibration target has passed completely through the laser plane, the calibration process will complete automatically. To properly calibrate the travel speed, the transport system must be running at the production operating speed before the target passes through the laser plane.
9. Inspect alignment results.
Data points from all sensors should now be aligned to the alignment target surface. The base of the alignment target (or target surface) provides the origin for the system Z axis.

Encoder Calibration

For systems that use an encoder, encoder calibration can be performed while aligning sensors. The table below summarizes the differences between performing alignment with and without encoder calibration.

	With encoder calibration	Without encoder calibration
Target Type	Calibration bar	Flat surface or calibration bar
Target/Sensor Motion	Linear motion	Stationary
Calibrates Z axis Offset	Yes	Yes
Calibrates Encoder	Yes	No
Calibrates Travel Speed	Yes	No

See *Coordinate Systems* on page 54 for definitions of coordinate axes. See *Alignment Targets* on page 25 for descriptions of calibration disks and bars.

See *Aligning Sensors* on page 107 for the procedure to perform alignment. After alignment, the coordinate system for laser ranges will change from sensor coordinates to system coordinates.

Clearing Alignment

Alignment can be cleared to revert the sensor to sensor coordinates.

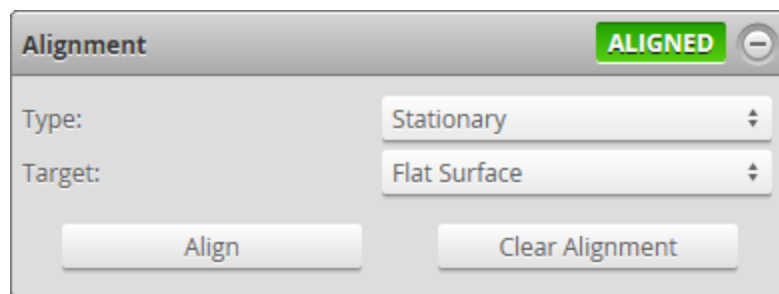

To clear alignment:

1. Go to the **Scan** page.
2. Expand the **Alignment** panel by clicking on the panel header or the \oplus button.
3. Click the **Clear Alignment** button.
The alignment will be erased and sensors will revert to using sensor coordinates.

Filters

Filters are used to post-process scan data along the X or Y axis to remove noise or clean it up *before* it is output or is used by measurement tools.

In some situations, such as when [Uniform Spacing](#) is disabled or when a sensor does not support filters, the filters panel is not displayed.

The following types of filters are supported:

Filter	Description
Gap Filling	Fills in missing data caused by occlusions using information from the nearest neighbors. Gap filling also fills gaps where no data is detected, which can be due to the surface reflectivity, for example dark or specular surface areas, or to actual gaps in the surface.
Median	Substitutes the value of a data point with the median within a specified window around the data point.
Smoothing	Applies moving window averaging to reduce random noise.
Decimation	Reduces the number of data points.
Slope	Useful for measuring high-frequency height changes when they are surrounded by lower frequency changes on the surface.

Filters are applied in the order displayed in the table above. The filters are configured in the **Filters** panel on the **Scan** page.

For more information, see the following sections.

Gap Filling

Gap filling works by filling in missing data points using either the lowest values from the nearest neighbors or linear interpolation between neighboring values (depending on the Z difference between neighboring values), in a specified X or Y window. The sensor can fill gaps along both the X axis and the Y axis.

 In Profile mode, gap filling is limited to the X axis. In Range mode, the filter is limited to the Y axis (direction of travel).

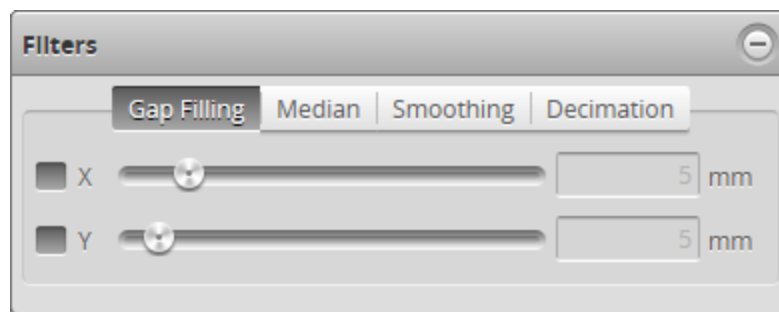

To configure X or Y gap filling:

1. Go to the **Scan** page.
2. Choose a mode other than Video in the **Scan Mode** panel. Otherwise, you will not be able to configure gap filling.
3. Expand the **Filters** panel by clicking on the panel header or the  button.
4. Click on the **Gap Filling** tab.
5. Enable the **X** or **Y** setting and select the maximum width value. The value represents the maximum gap width that the sensor will fill. Gaps wider than the maximum

width will not be filled.

6. Save the job in the **Toolbar** by clicking the **Save** button .
7. Check that the scan data is satisfactory.

Median



The Median filter substitutes the value of a data point with the median calculated within a specified window around the data point.

 In Profile mode, gap filling is limited to the X axis. In Range mode, the filter is limited to the Y axis (direction of travel).

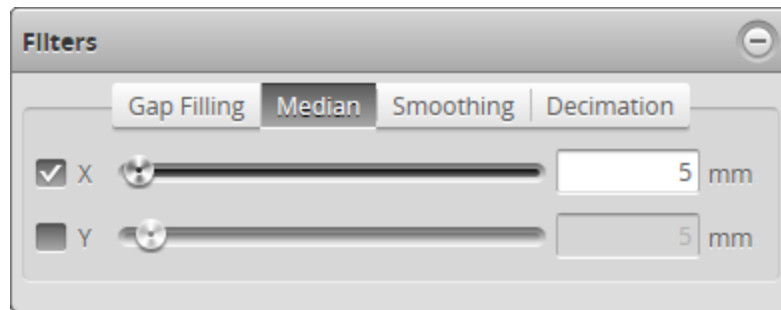
 Missing data points will not be filled with the median value calculated from data points in the neighbourhood.



To configure X or Y median:

1. Go to the **Scan** page.
2. Choose a mode other than Video in the **Scan Mode** panel. Otherwise, you will not be able to configure the median filter.
3. Expand the **Filters** panel by clicking on the panel header or the  button.
4. Click on the **Median** tab.
5. Enable the **X** or **Y** setting and select the maximum width value.
6. Save the job in the **Toolbar** by clicking the **Save** button .
7. Check that the scan data is satisfactory.

Smoothing

Smoothing works by substituting a data point value with the average value of that data point and its nearest neighbors within a specified window. Smoothing can be applied along the X axis or the Y axis. X smoothing works by calculating a moving average across samples within the same profile. Y smoothing works by calculating a moving average in the direction of travel at each X location.

 In Profile mode, gap filling is limited to the X axis. In Range mode, the filter is limited to the Y axis (direction of travel).



Missing data points will not be filled with the mean value calculated from data points in the neighbourhood.

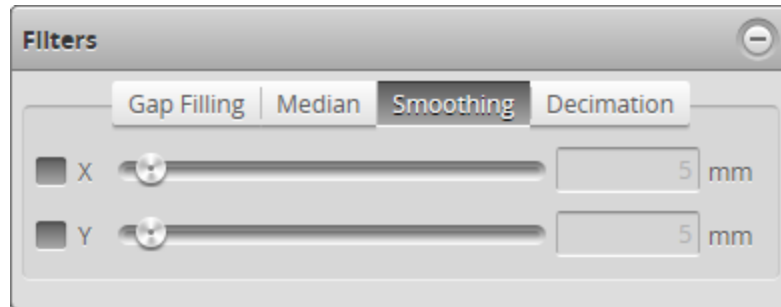

To configure X or Y smoothing:

1. Go to the **Scan** page.
2. Choose a mode other than Video in the **Scan Mode** panel. Otherwise, you will not be able to configure smoothing.
3. Expand the **Filters** panel by clicking on the panel header or the \oplus button.
4. Click on the **Smoothing** tab.
5. Enable the **X** or **Y** setting and select the averaging window value.
6. Save the job in the **Toolbar** by clicking the **Save** button .
7. Check that the scan data is satisfactory.

Decimation

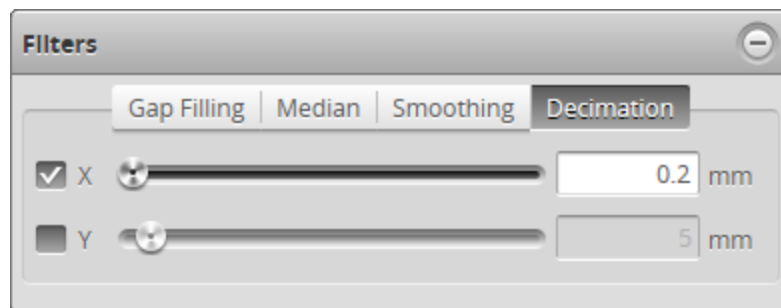

Decimation reduces the number of data points along the X or Y axis by choosing data points at the end of a specified window around the data point. For example, by setting X to .2, only points every .2 millimeters will be used.



In Profile mode, gap filling is limited to the X axis. In Range mode, the filter is limited to the Y axis (direction of travel).

To configure X or Y decimation:

1. Go to the **Scan** page.

2. Choose a mode other than Video in the **Scan Mode** panel.
Otherwise, you will not be able to configure the decimation filter.
3. Expand the **Filters** panel by clicking on the panel header or the  button.
4. Click on the **Decimation** tab.
5. Enable the **X** or **Y** setting and select the decimation window value.
6. Save the job in the **Toolbar** by clicking the **Save** button .
7. Check that the scan data is satisfactory.

Slope

Slope modifies profile data in way that emphasizes high-frequency height changes when they are surrounded by lower frequency changes on the surface. You can use the filter, for example, to easily measure the position of edges on a wavy surface.

An example is a [generated profile](#) that looks like this:

Without Slope filter

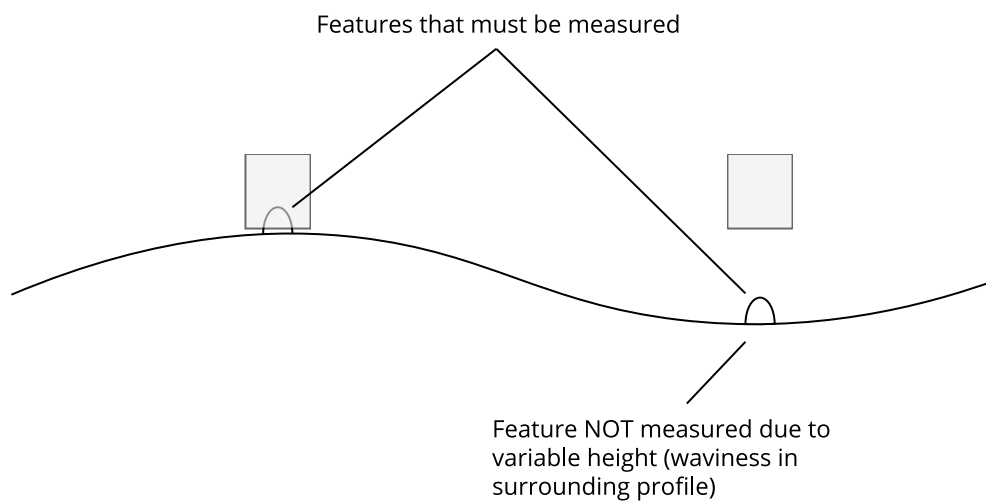

With Slope filter

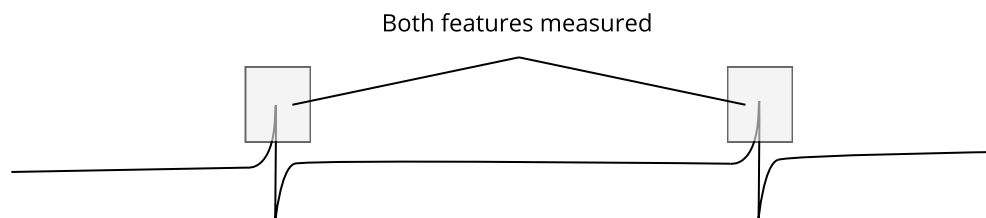

In the top profile (no filter applied), the second feature would be missed by a [Position Z](#) measurement, because the feature has moved beyond the region of interest defined for the measurement. When the filter is applied, the profile around the features is "evened out"—even though the overall height is greater than the features that must be detected—and the more abrupt changes of the features are emphasized. As a result, the position of the features can easily be measured.

The filter can be used in both Range and Profile mode.

Profile Generation

The sensor can generate a profile by combining a series of ranges gathered along the direction of travel.

The sensor uses different methods to generate the data, depending on the needs of the application. Data generation is configured in the **Profile Generation** panel on the **Scan** page.

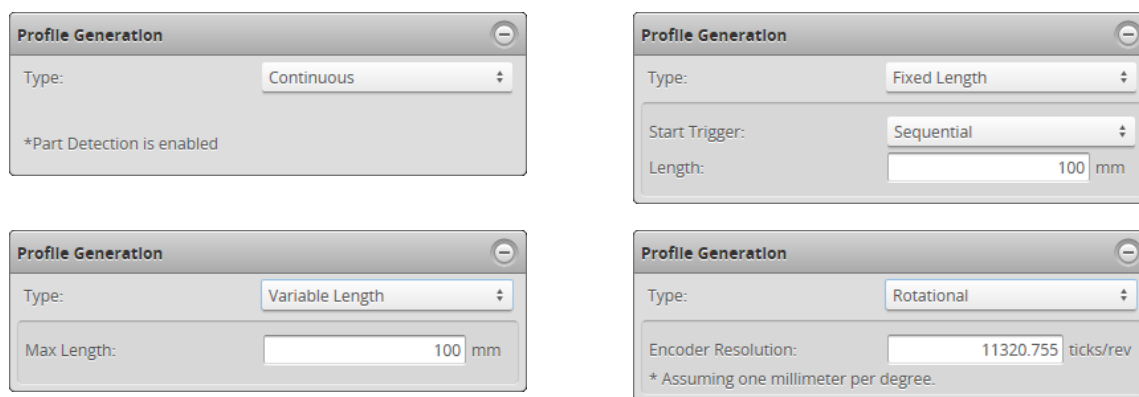

The types in the table below correspond to the **Type** setting in the panel.

When **Type** is set to **Continuous**, part detection is automatically enabled. When **Type** is set to any of the other settings, part detection can be enabled and disabled in the **Part Detection** panel. For descriptions of the settings that control part detection logic, *Part Detection* on page 118.

Continuous: The sensor continuously generates profiles of parts that are detected under the sensor. This type is typically used when the transport system continuously feeds material or parts under a sensor. The materials have a distinguishable start and stop edge, such as in when detecting wane (the curved part on boards cut from logs that must be removed).

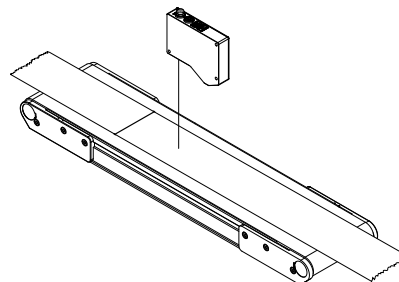

Fixed Length: The sensor generates profiles of a fixed length (in mm) using the value in the **Length** setting. Like Continuous mode, Fixed Length mode is used when material or parts continuously pass under the sensor. Unlike Continuous mode, parts/material do not have distinguishable start and stop edge. Examples include measuring height characteristics of rubber extrusions or road roughness calculations.

For correct length measurement, you should ensure that motion is calibrated (that is, encoder resolution for encoder triggers or travel speed time triggers).

The following types of start triggers are available under **Start Trigger**:

- **Sequential:** Continuously generates back-to-back fixed length profiles.
- **External Input:** A pulse on the digital input triggers the generation of a single profile of fixed length.
- **Software:** Allows starting fixed length surfaces on command from PLC or PC.

For more information on connecting external input to a sensor, see *Digital Input* on page 542.

You can optionally enable part detection to process the profile after it has been generated, but the generation itself does not depend on the detection logic. To do this, check **Enabled** in the **Part Detection** panel.

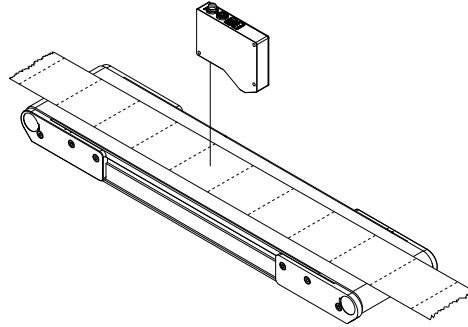

Variable Length: The sensor generates profiles of variable length while the external digital input is held high. If the value of the **Max Length** setting is reached while external input is still high, the next profile starts immediately. This mode is typically used in robot-mounted applications, for example, measuring the lengths of different parts on an engine block.

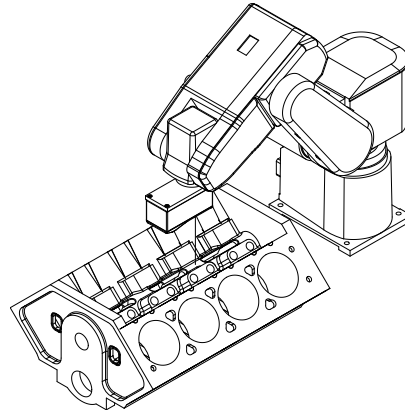

For correct length measurement, you should ensure that motion is calibrated (i.e., encoder resolution for encoder triggers or travel speed for time triggers).

For more information on connecting external input to a sensor, see *Digital Input* on page 542.

You can optionally enable part detection to process the profile after it has been generated, but the generation itself does not depend on the detection logic. To do this, check **Enabled** in the **Part Detection** panel.

Rotational: The sensor reorders ranges within a profile to be aligned with the encoder's index pulse so that the system knows when a full rotation has completed. That is, regardless of the radial position the sensor is started at, the generated profile always starts at the position of the index pulse. If the index pulse is not detected and the rotation circumference is met, the profile is dropped and the Encoder Index Drop indicator will be incremented. This mode is typically used in applications where measurements of circular objects or shafts need to be taken, such as tire tread inspection, or label

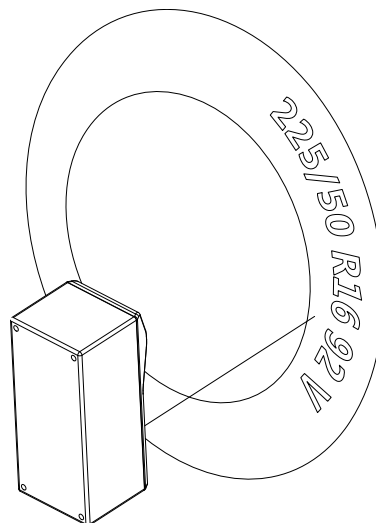

positioning on bottles.



To scan exactly one revolution of a circular target without knowing the circumference, manually set the encoder resolution (page 80) to 1, the encoder trigger spacing (page 91) to $(\text{number of encoder ticks per revolution}) / (\text{number of desired profiles per revolution})$, and **Encoder Resolution** in the **Profile Generation** panel to the number of encoder ticks per revolution.

You can optionally enable part detection to process the profile after it has been generated, but the generation itself does not depend on the detection logic. To do this, check **Enabled** in the **Part Detection** panel.

To configure profile generation:

1. Go to the **Scan** page and choose **Profile** in the **Scan Mode** panel.
If this mode is not selected, you will not be able to configure surface generation.
2. Expand the **Profile Generation** panel by clicking on the panel header or the  button.
3. Choose an option from the **Type** drop-down and any additional settings.
See the types and their settings described above.

Part Detection

In Profile mode, the Gocator sensor can analyze profiles created by combining range values to identify discrete objects.

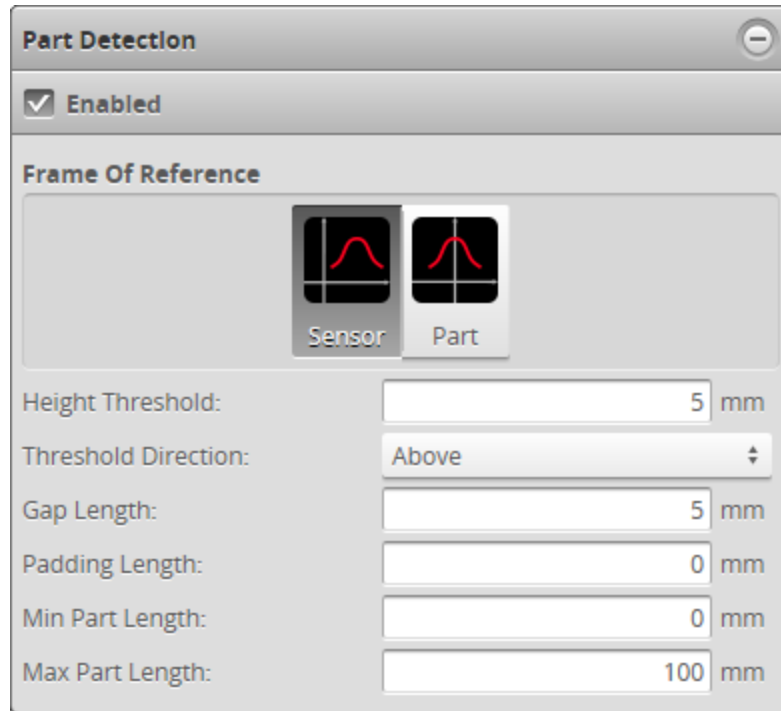

The following settings can be tuned to improve the accuracy and reliability of part detection.

Setting	Description
Height Threshold	Determines the height threshold for part detection. The setting for Threshold Direction determines if parts should be detected above or below the threshold. Above is typically used to prevent the belt surface from being detected as a part when scanning objects on a conveyor.
Threshold Direction	Determines if parts should be detected above or below the height threshold.
Gap Length	Determines the minimum separation between objects on the Y axis. If parts are closer than the gap interval, they will be merged into a single part.
Padding Length	Determines the amount of extra data on the Y axis from the surface surrounding the detected part that will be included. This is mostly useful when processing part data with third-party software such as HexSight, Halcon, etc.
Min Part Length	Determines the minimum length of the part object.
Max Part Length	Determines the maximum length of the part object. When the object exceeds the maximum length, it is automatically separated into two parts. This is useful to break a long object into multiple sections and perform measurements on each section.
Frame of Reference	Determines the coordinate reference for surface measurements. When Profile Generation is set to Continuous , only Part is available. See <i>Profile Generation</i> on page 115 for more information.

Sensor

When **Frame of Reference** is set to **Sensor**, the sensor's frame of reference is used.

Setting	Description
	<p>The way the sensor's frame of reference is defined changes depending on the profile generation Type setting (<i>Profile Generation</i> on page 115 and for more information):</p> <ul style="list-style-type: none"> • When parts are segmented from a continuous surface (the profile generation Type setting is set to Continuous), measurement values are relative to a Y origin at the center of the part (the same as for Part frame of reference; see below). • When parts are segmented from other types of profiles (the profile generation Type setting is set to Fixed Length, Variable Length, or Rotational), measurement values are relative to a Y origin at the center of the surface from which the part is segmented. <p>Part</p> <p>When Frame of Reference is set to Part, all measurements are relative to the center of the bounding box of the part.</p>

To set up part detection:

1. Go to the **Scan** page and choose **Profile** in the **Scan Mode** panel.
If this mode is not selected, you will not be able to configure part detection.
2. Expand the **Part Detection** panel by clicking on the panel header or the  button.
3. If necessary, check the **Enabled** option.
When **Profile Generation** is set to **Continuous**, part detection is always enabled.
4. Adjust the settings.
See the part detection parameters above for more information.

Data Viewer

The data viewer can display video images, ranges, profiles, and intensity images. It is also used to configure the active area (*Active Area* on page 98) and measurement tools (see *Measurement and Processing* on page 127). The data viewer changes depending on the current operation mode and the panel that has been selected.

Data Viewer Controls

The data viewer is controlled by mouse clicks and by the buttons on the display toolbar. The mouse wheel can also be used for zooming in and out when viewing [generated profiles](#).

When the sensor displays profiles, a safety goggle mode button () is available above the data viewer. Enabling this mode changes some colors to ensure that profiles are visible in the data viewer when wearing laser safety goggles.

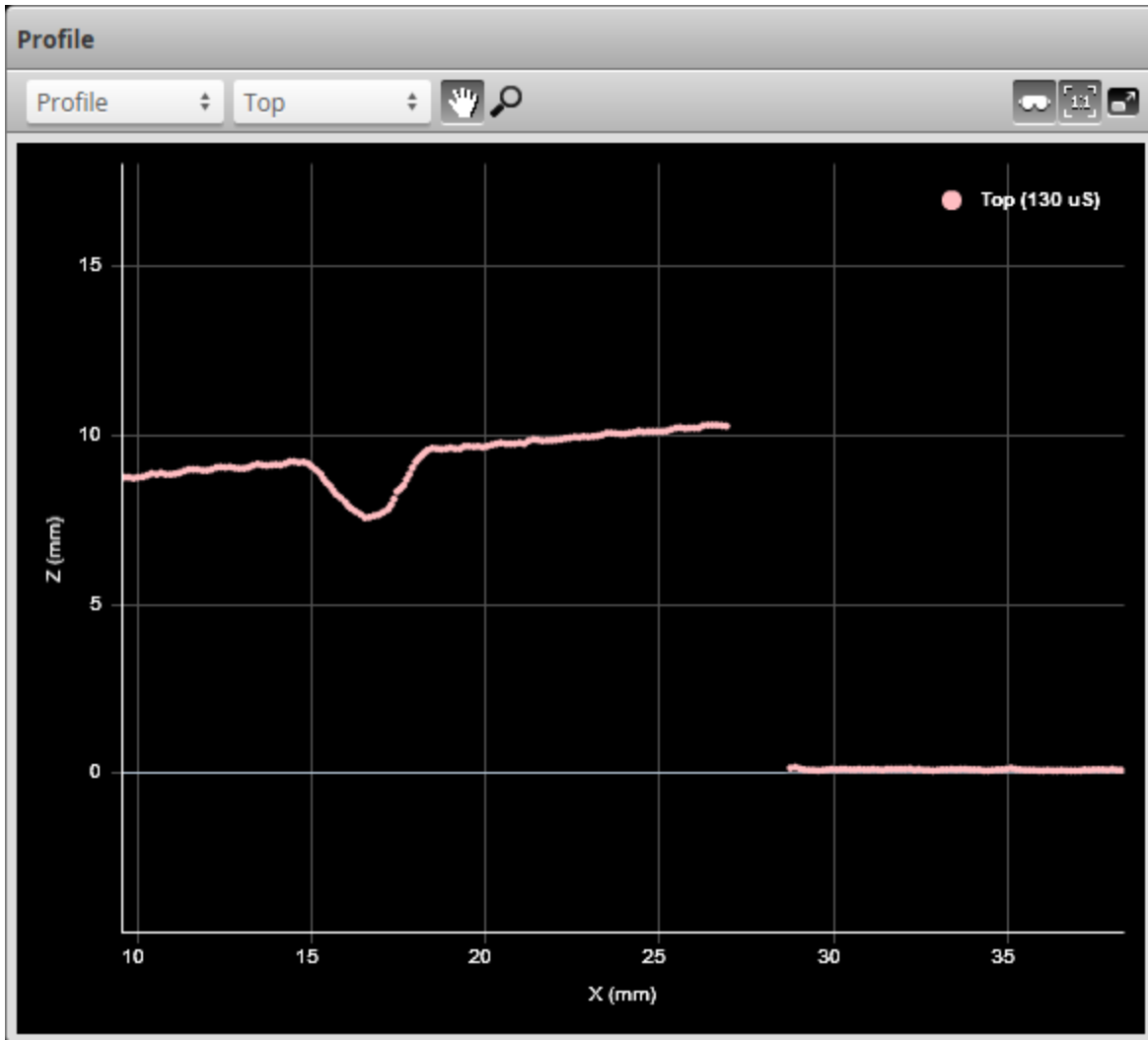

Video Mode

In Video mode, the data viewer displays images directly from the sensor's camera or cameras. In a dual-sensor system, camera images from either sensor can be displayed.

In this mode, you can configure the data viewer to display exposure, spot, and dropout information that can be useful in properly setting up the system for scanning.

Spots and Dropouts

Various settings can affect how the **Material** settings behave. In Video mode, you can examine how the **Material** settings are affected. To do this, in Video mode, check the **Show Spots** option at the top of the data viewer to overlay a representation of the spot in the data viewer.

In the image below, the white and gray squares represent the laser point as it appears on the camera sensor. The spot (which represents the center of the laser point on the camera sensor) is displayed as a red "x" symbol. A dropout would be displayed as a yellow dot.

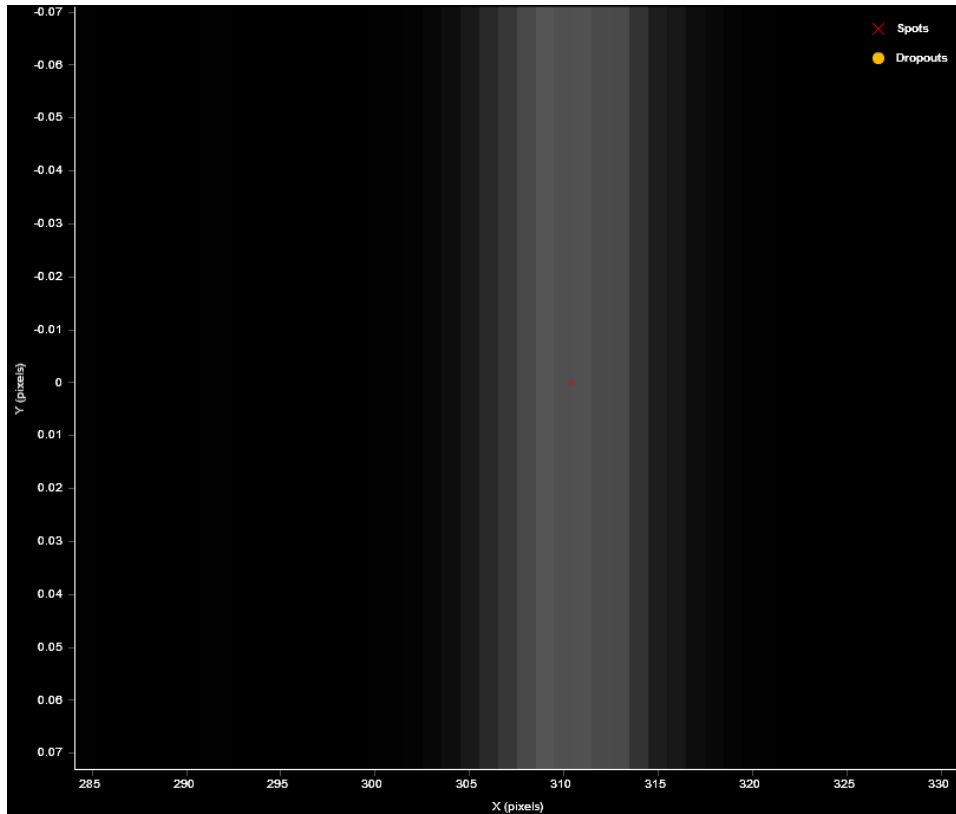

To show data dropouts:

1. Go to the **Scan** page and choose **Video** mode in the **Scan Mode** panel.
2. check the **Show Dropouts** option at the top of the data viewer.

For more information on the material settings, see *Advanced* on page 103.

Range Mode

When the Gocator is in Range scan mode, the data viewer displays range, intensity, and measurement information as numerical values and bars. Color is used to indicate pass / fail in the case of measurement decisions.

The Range value indicates where along the measurement range that the target falls. The bars indicate how close the target is to the near end (more bars, farther to the right) or the far end (fewer bars, farther to the left) of the measurement range. In the image below, the bars indicate that at 45.773 mm, the target is close to the near end of the measurement range of that sensor.

The Intensity value is on a scale of 0 to 255 and indicates the intensity at the laser point. The bars provide a graphical representation of this value. The **Acquire Intensity** option must be enabled in the **Scan Mode** panel for the Intensity value and bar to be displayed.

The Measurement value indicates the measured value of the target. If the measured value falls between the Min and Max decision values (a pass decision), the measurement and bars are green. The bars indicate graphically where, between the Min and Max decision values, the measured value falls. If the

measured value falls outside the Min and Max decision values (a fail decision), the measurement is red and no bars are displayed. If the measurement is invalid, a "---" indicator is displayed instead of a value, and the bars and this indicator are red.

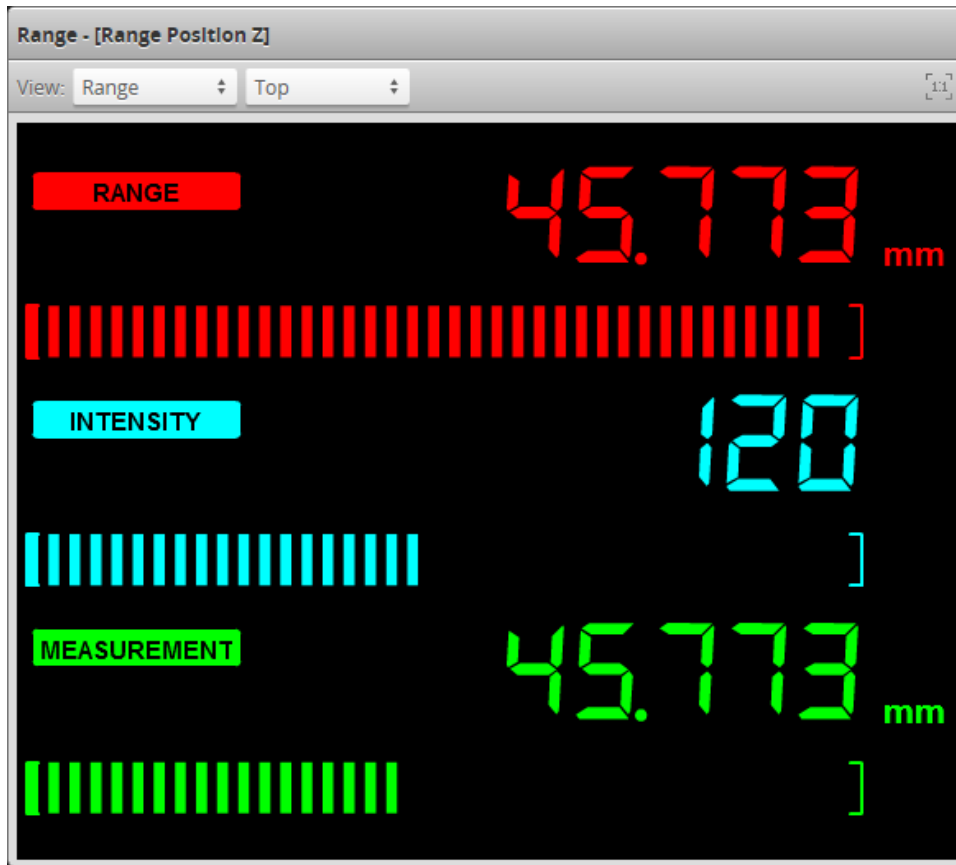

In a dual-sensor system, the sensor used to display ranges can be selected.

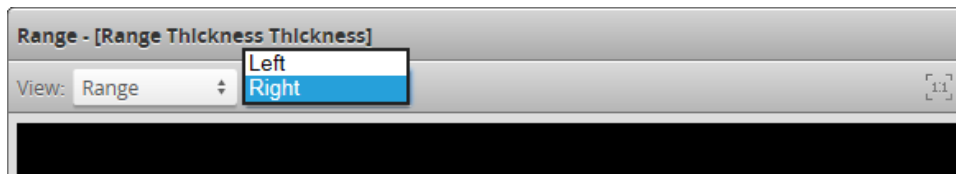

To manually select the display view in the Scan page:

1. Go to the **Scan** page and choose **Range** mode in the **Scan Mode** panel.
2. Select the view in the data viewer.

When the **Measure** page is active, the view of the display is set to the range source of the selected measurement tool (*Measurement and Processing* on page 127).

Profile Mode

When the sensor is in Profile scan mode, the data viewer displays profile plots.

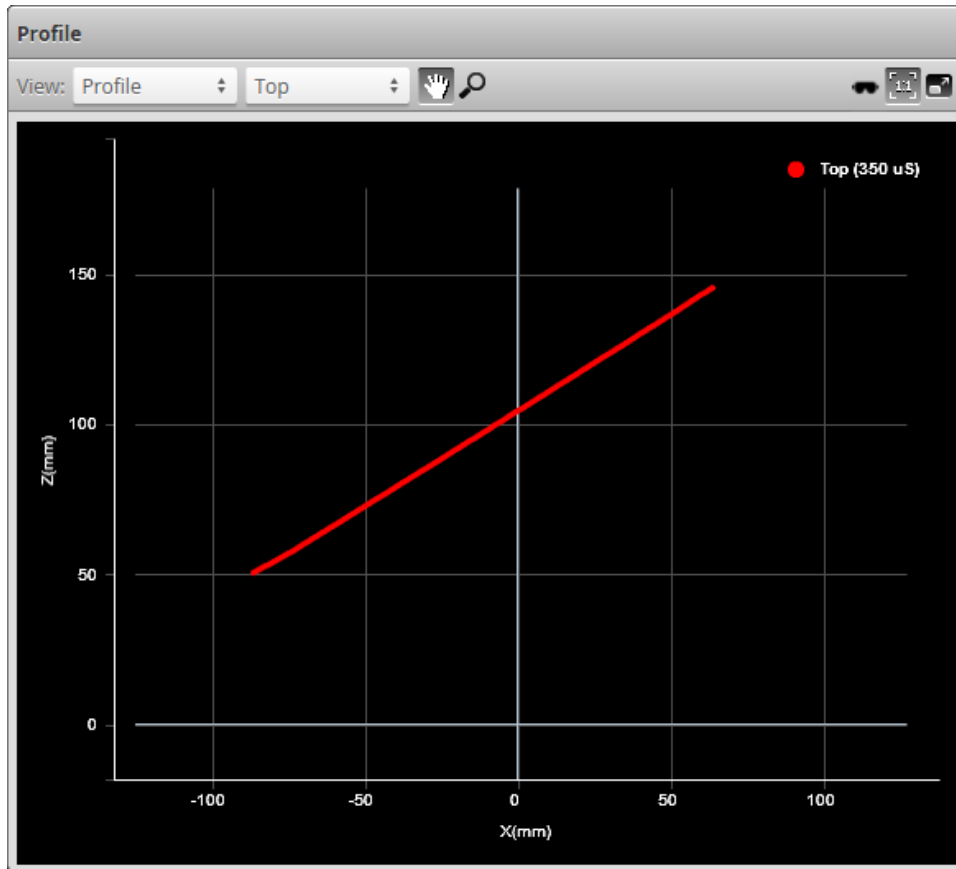

In a dual-sensor system, profiles from individual sensors or from a combined view can be displayed.

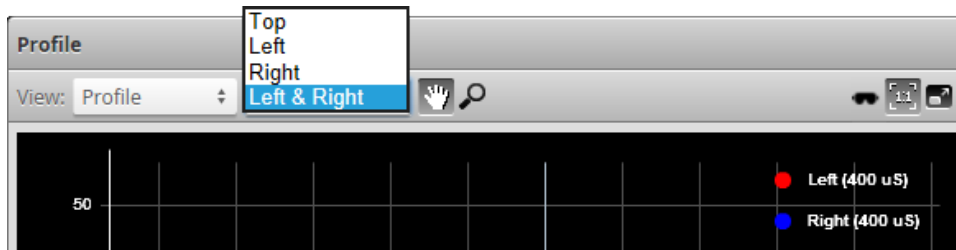

When in the **Scan** page, selecting a panel (e.g., **Sensor** or **Alignment** panel) automatically sets the display to the most appropriate display view.

To manually select the display view in the Scan page:

1. Go to the **Scan** page.
2. Choose **Profile** mode in the **Scan Mode** panel.
3. Select the view.
 - Top:** View from a single sensor, from the top sensor in an opposite-layout dual-sensor system, or the combined view of sensors in the top position.
 - Bottom:** View from the bottom sensor in an opposite-layout dual-sensor system.

Left: View from the left sensor in a dual-sensor system.

Right: View from the right sensor in a dual-sensor system.

Left & Right: In a dual-sensor system, views from both sensors, displayed at the same time in the data viewer, using the coordinate systems of each sensor.

In the **Measure** page, the view of the display is set to the profile source of the selected measurement tool.

Region Definition

Regions, such as an active area or a measurement region, can be graphically set up using the data viewer.

When the **Scan** page is active, the data viewer can be used to graphically configure the active area. The **Active Area** setting can also be configured manually by entering values into its fields and is found in the **Sensor** panel (see *Sensor* on page 98).

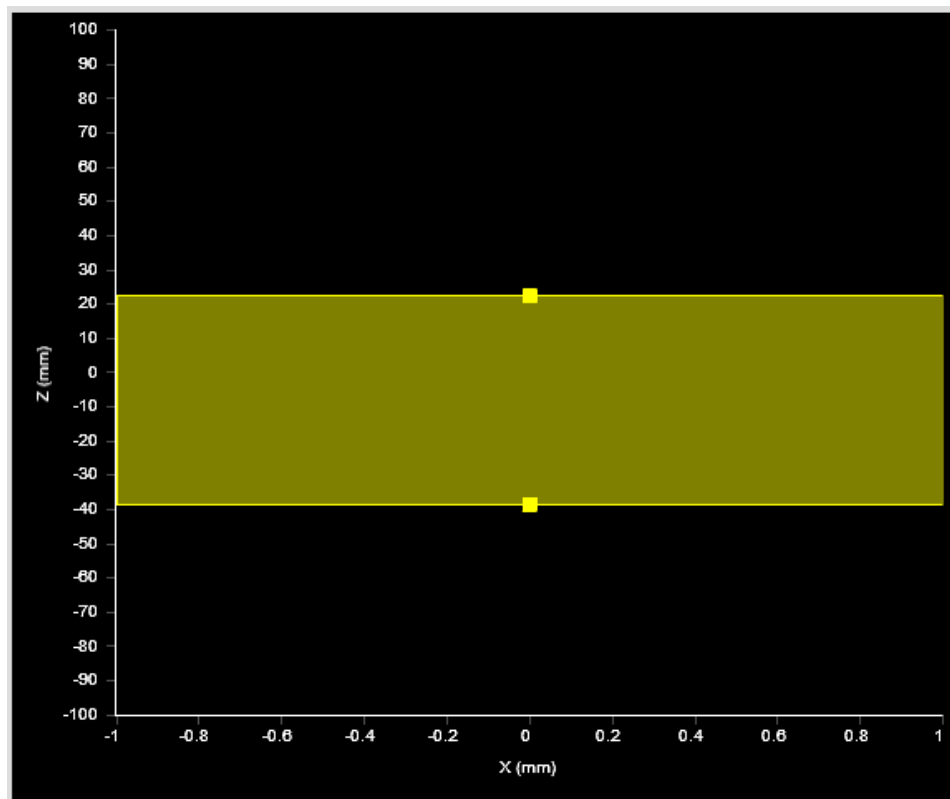

To set up a region of interest:

1. Move the mouse cursor to the rectangle.
The rectangle is automatically displayed when a setup or measurement requires an area to be specified.
2. Drag the rectangle to move it, and use the handles on the rectangle's border to resize it.

Intensity Output

Gocator sensors can produce intensity data that measure the amount of light reflected by an object. An 8-bit intensity value is output for each range value.

To display intensity data, click the Intensity button .



To be able to display intensity data, you must enable **Acquire Intensity** in the **Scan Mode** panel.

Measurement and Processing

The following sections describe Gocator's measurement and processing tools.

Measure Page Overview

Measurement tools are added and configured in the **Measure** page.

The content of the **Tools** panel in the **Measure** page depends on the current scan mode. In Range mode, the **Measure** page displays tools for range measurement. In Profile mode, the **Measure** page displays tools for profile measurement. In Video mode, tools are not available.

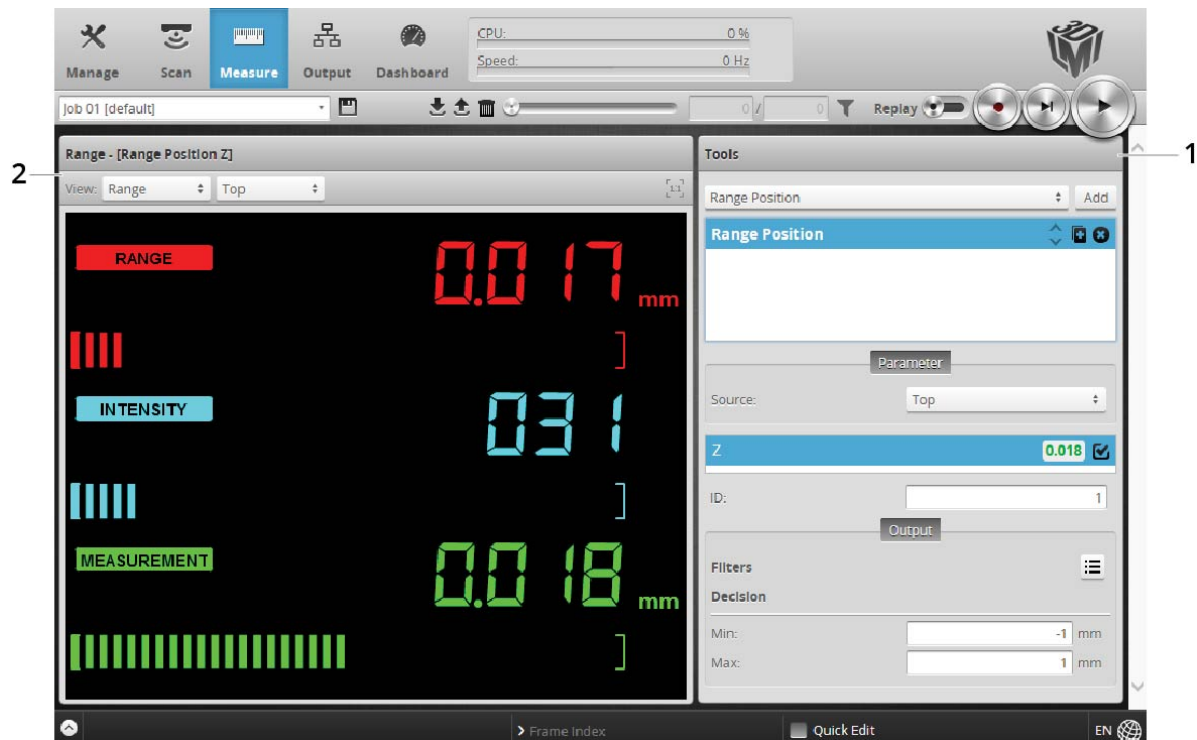

Element	Description
1	Tools panel Used to add, manage, and configure tools and measurements (see <i>Tools Panel</i> on page 129).
2	Data Viewer Displays video and scan data, sets up tools, and displays result calipers related to the selected measurement. <i>See Data Viewer below.</i>

Data Viewer

When the **Measure** page is active, the data viewer can be used to graphically configure measurement regions. Measurement regions can also be configured manually in measurements by entering values into the provided fields (see *Regions* on page 130).

For information on controls in the data viewer, see *Data Viewer Controls* on page 120.

For instructions on how to set up measurement regions graphically, see *Region Definition* on page 125.

Tools Panel

The **Tools** panel lets you add, configure, and manage measurement tools. Tools contain related measurements.

Some settings apply to tools, and therefore to all measurements; these settings are found in the **Parameters** tab below the list of tools. Other settings apply to specific measurements, and are found in a **Parameters** tab below the list of measurements; not all measurements have parameters.

See *Range Measurement* on page 144 for information on the measurement tools and their settings.



Tool names in the user interface include the scan mode, but not in the manual. So for example, you will see "Range Position" in the user interface, but simply "Position" in the manual.

Adding and Configuring a Measurement Tool

Adding a tool adds all of the tool's measurements to the **Tools** panel. You can then enable and configure the measurements selectively.

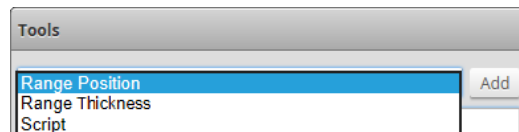

To add and configure a tool:

1. Go to the **Scan** page by clicking on the **Scan** icon.
2. Choose Range or Profile mode in the **Scan Mode** panel.
If one of these modes is not selected, tools will not be available in the **Measure** panel.
3. Go to the **Measure** page by clicking on the **Measure** icon.
4. In the Tools panel, select the tool you want to add from the drop-down list of tools.
5. Click on the **Add** button in the Tools panel.
The tool and its available measurements are added to the tool list. The tool parameters are listed in the area below the tool list.
6. (Optional) If you are running a dual-sensor system, choose the sensor that will provide data to the measurement tool in **Source**.
For more information on sources, see *Source* on the next page.
7. Select a measurement at the bottom of the tool panel.
8. Set any tool- or measurement-specific settings.
For tool- and measurement-specific settings, see the topics for the individual [range](#) or [profile](#) tools.
9. Set the **Min** and **Max** decision values.
For more information on decisions, see *Decisions* on page 134.
10. (Optional) Set one or more filters.
For more information on filters, see *Filters* on page 136.

11. (Optional) Set up anchoring.

For more information on anchoring, see *Measurement Anchoring* on page 137.

Source

For dual-sensor systems, you must specify which sensor, or combination of sensors, provides data for a measurement tool.

 The **Source** setting applies to all of a tool's measurements.

Depending on the layout you have selected, the **Source** drop-down will display one of the following (or a combination). For more information on layouts, see *Layout* on page 75.

Setting	Description
Top	The Main sensor in a standalone system. In a dual-sensor system, refers to the Main sensor in Opposite layout, or to the combined data from both the Main and Buddy sensors.
Bottom	The Buddy sensor in Opposite layout in a dual-sensor system.
Top & Bottom	In a dual-sensor system, refers to the combined data from the Main and Buddy sensor.
Top Left	Refers to a Main sensor in Wide layout or to a Buddy sensor in Reverse layout in a dual-sensor system.
Top Right	Refers to a Buddy sensor in Wide layout or to a Main sensor in Reverse layout in a dual-sensor system.

To select the source:

1. Go to the **Measure** page by clicking on the **Measure** icon.

 The [scan mode](#) must be set to the type of measurement you need to configure. Otherwise, the wrong tools, or no tools, will be listed on the **Measure** page.

2. In the **Tools** panel, click on a tool in the tool list.
3. If it is not already selected, click on the **Parameter** tab in the tool configuration area.
4. Select the profile source in the **Source** drop-down list.

Regions

Many measurement tools use user-defined regions to limit the area in which measurements occur. Unlike reducing the [active area](#), reducing the measurement region does not increase the maximum frame rate of the sensor.

 You can disable regions entirely and cause the measurement tool uses the entire [active area](#) by unchecking the checkbox next to the **Regions** setting.

All tools provide region settings under the upper **Parameters** tab. This region applies to all of a tool's measurements.

Region
↺
☰

X:

-54.122

mm

Z:

-36.593

mm

Width:

109.67

mm

Height:

109.67

mm

Region settings are often found within expandable feature sections in the tool's panel.

To configure regions:

1. Go to the **Measure** page by clicking on the **Measure** icon.

The [scan mode](#) must be set to the type of measurement you need to configure. Otherwise, the wrong tools, or no tools, will be listed on the **Measure** page.

2. In the **Tools** panel, click on a tool in the tool list.
3. Configure the region using the mouse in the data viewer.
You can also configure regions manually by clicking the expand button (☰) and entering values in the fields. This is useful if you need to set precise values.

Feature Points

Dimensional and positional measurements detect *feature points* found within the defined [measurement region](#) and then compare measurement values taken at the selected point with minimum and maximum thresholds to produce a *decision*. Feature points are selected in one or more **Feature** dropdowns in a tool and are used for all of the tool's measurements.

The following types of points can be identified in a measurement region.

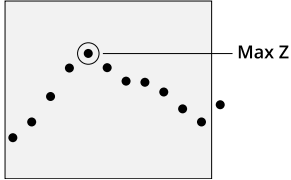
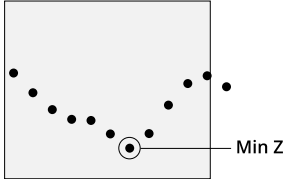
Point Type	Examples
<p>Max Z</p> <p>Finds the point with the maximum Z value in the region of interest.</p>	
<p>Min Z</p> <p>Finds the point with the minimum Z value in the region of interest.</p>	

Point Type**Examples**

Min X

Finds the point with the minimum X value in the region of interest.

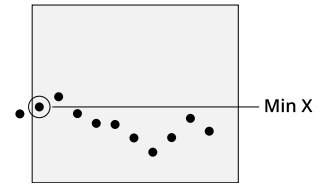
**Max X**

Finds the point with the maximum X value in the region of interest.

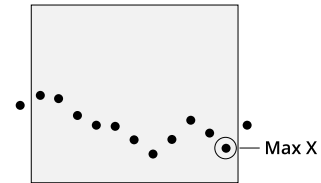
**Average**

Determines the average location of points in the region of interest.

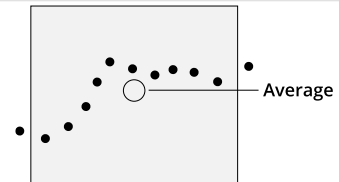
**Corner**

Finds a dominant corner in the region of interest, where corner is defined as a change in profile slope.

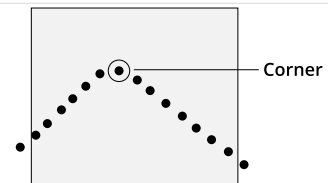
**Top Corner**

Finds the top-most corner in the region of interest, where corner is defined as a change in profile shape.

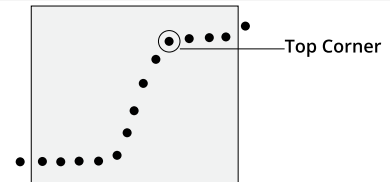
**Bottom Corner**

Finds the bottom-most corner in the region of interest, where corner is defined as a change in profile shape.

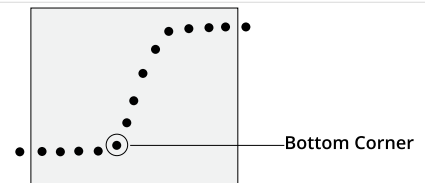
**Left Corner**

Finds the left-most corner in the region of interest, where corner is defined as a change in profile shape.

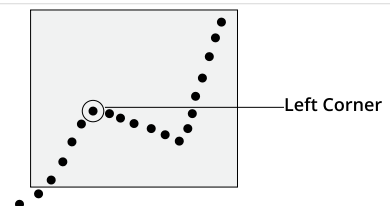

Point Type

Examples

Right Corner

Finds the right-most corner in the region of interest, where corner is defined as a change in profile shape.

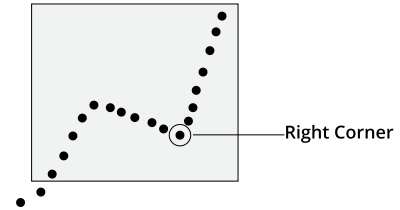

Rising Edge

Finds a rising edge in the region of interest (moving from left to right).

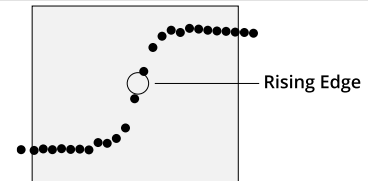

Falling Edge

Finds a falling edge in the region of interest (moving from left to right).

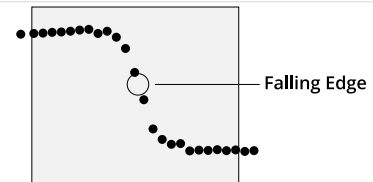

Any Edge

Finds a rising or falling edge in the region of interest.

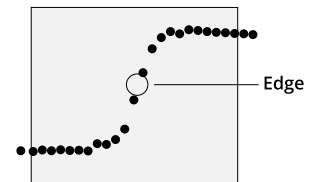
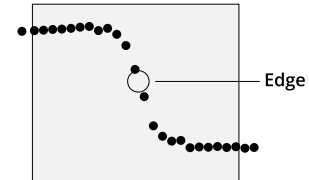

Median

Determines the median location of points in the region of interest.

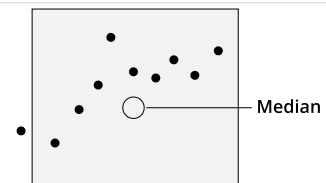

Geometric Features

Many [Profile tools](#) can output features that [Feature tools](#) can take as input to produce measurements. These features are called *geometric features*. Feature tools use these entities to produce measurements based on more complex geometry. (For more information on Feature tools, see *Feature Measurement* on page 215.)

Gocator's measurement tools can currently generate the following kinds of geometric features:

Points: A 2D point. Can be used for point-to-point or point-to-line measurements.

Lines: A straight line that is infinitely long. Useful for locating the orientation of an enclosure or part, or to intersect with another line to form a reference point that can be consumed by a Feature tool.

The following tables list the tools that can generate geometric features. (Tools that can't generate geometric features are excluded.)

Geometric features generated by Profile tools

Tool	Point	Line
Area	X	
Bounding Box	X	
Circle	X	
Intersect	X	X
Line	X	X
Position	X	

The [Feature Intersect](#) tool can also produce an intersect point. [Script tools](#) do not currently take geometric features as input.

Fit Lines

Some measurements involve estimating lines in order to measure angles or intersection points. A fit line can be calculated using data from either one or two fit areas.

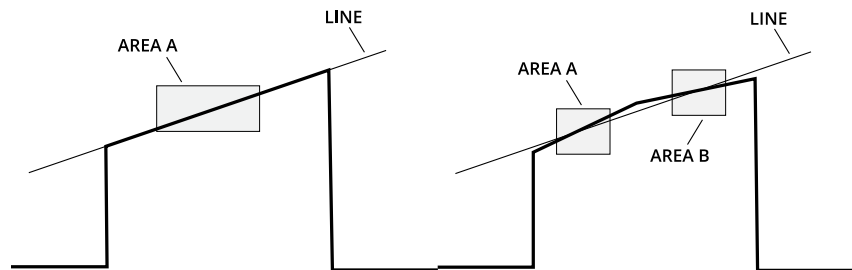

A line can be defined using one or two areas. Two areas can be used to bypass discontinuity in a line segment.

Decisions

Results from a measurement can be compared against minimum and maximum thresholds to generate *pass / fail* decisions. The decision state is *pass* if a measurement value is between the minimum and maximum threshold. In the data viewer and next to the measurement, these values are displayed in green. Otherwise, the decision state is *fail*. In the user interface, these values are displayed in red.

All measurements provide decision settings under the **Output** tab.

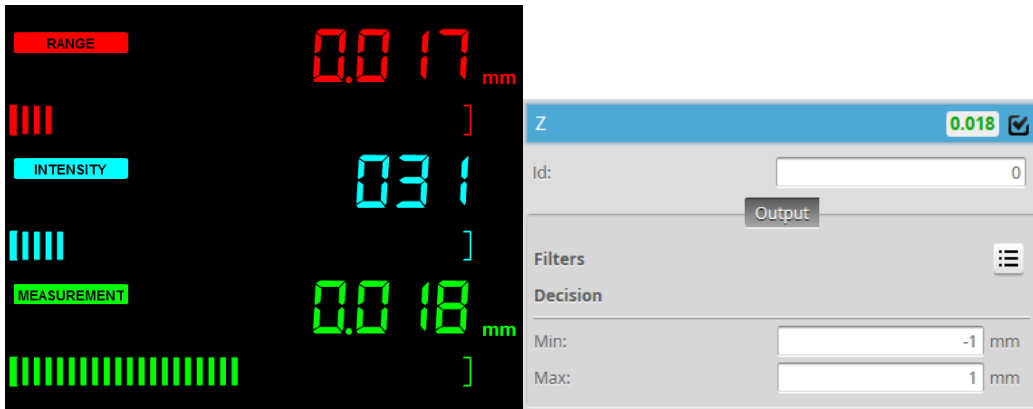

Value (5.736) within decision thresholds (Min: 5, Max: 6). Decision: Pass

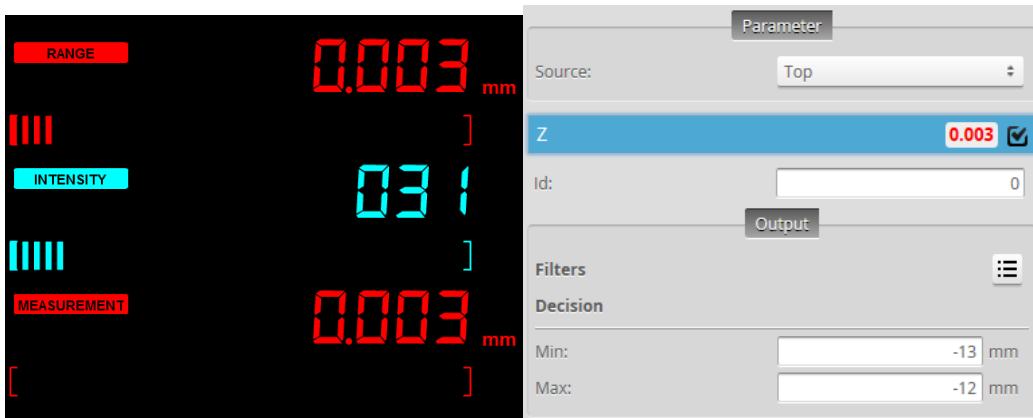

Value (-13.880) outside decision thresholds (Min: -13, Max: -12). Decision: Fail

Along with measurement values, decisions can be sent to external programs and devices. In particular, decisions are often used with digital outputs to trigger an external event in response to a measurement. See *Output* on page 234 for more information on transmitting values and decisions.

To configure decisions:

1. Go to the **Measure** page by clicking on the **Measure** icon.

 The [scan mode](#) must be set to the type of measurement you need to configure. Otherwise, the wrong tools, or no tools, will be listed on the **Measure** page.

2. In the **Tools** panel, click on a tool in the tool list.
3. In the measurement list, select a measurement.
To select a measurement, it must be enabled. See *Enabling and Disabling Measurements* on page 140 for instructions on how to enable a measurement.
4. Click on the **Output** tab.
For some measurements, only the **Output** tab is displayed.
5. Enter values in the **Min** and **Max** fields.

Filters

Filters can be applied to measurement values before they are output from the Gocator sensors.

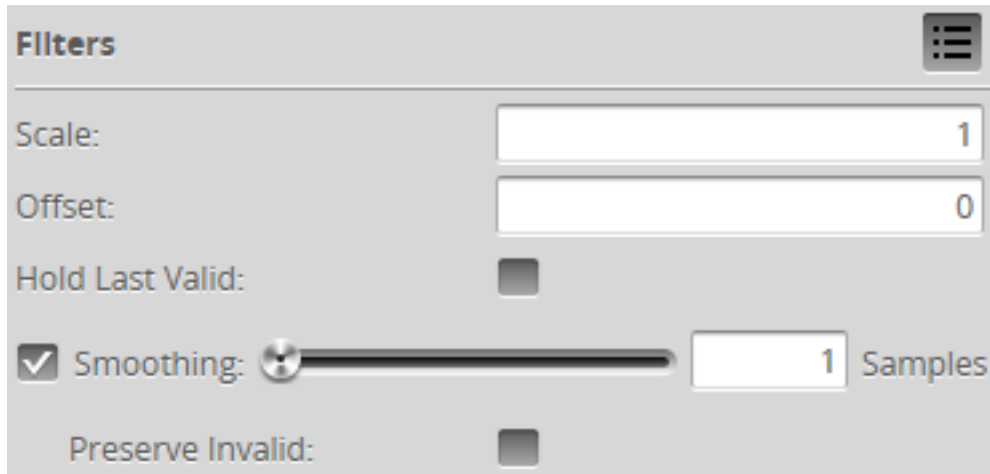

All measurements provide filter settings under the **Output** tab. The following settings are available.

Filter	Description
Scale and Offset	<p>The Scale and Offset settings are applied to a measurement value according to the following formula:</p> $\text{Scale} * \text{Value} + \text{Offset}$ <p>Scale and Offset can be used to transform the output without the need to write a script. For example, to convert the measurement value from millimeters to thousands of an inch, set Scale to 39.37. To convert from radius to diameter, set Scale to 2.</p> <p>For more information on scripts, see <i>Scripts</i> on page 228.</p>
Hold Last Valid	Holds the last valid value when the measurement is invalid.
Smoothing	<p>Averages the <i>valid</i> measurements in the number of preceding frames specified in Samples. Use this to reduce the impact of random noise on a measurement's output.</p> <p>If Hold Last Valid is enabled, the smoothing filter uses the last valid measurement value until a valid value is encountered.</p>
Preserve Invalid	<p>When enabled, smoothing is only applied to valid measurements and not to invalid results: invalid results are not modified and are sent to output as is.</p> <p>When disabled, smoothing is applied to both valid and invalid results. (This setting is only visible when Smoothing is enabled.)</p> <p>If Hold Last Valid is enabled, results will always be valid, in which case this setting does nothing.</p>

To configure the filters:

1. Go to the **Measure** page by clicking on the **Measure** icon.



The [scan mode](#) must be set to the type of measurement you need to configure. Otherwise, the wrong tools, or no tools, will be listed on the **Measure** page.

2. In the **Tools** panel, click on a tool in the tool list.
3. In the measurement list, select a measurement.
To select a measurement, it must be enabled. See *Enabling and Disabling Measurements* on page 140 for instructions on how to enable a measurement.
4. Click on the **Output** tab.
For some measurements, only the **Output** tab is displayed.
5. Expand the **Filters** panel by clicking on the panel header or the  button.
6. Configure the filters.
Refer to the table above for a list of the filters.

Measurement Anchoring

Measurement anchoring is used to track the movement of parts within the field of view of the sensor, compensating for variations in the height and position of parts. The movement is calculated as an offset from the position of a measured feature, where the offset is then used to correct the positions of measurement regions of other measurement tools. This ensures that the regions used to measure features are correctly positioned for every part.

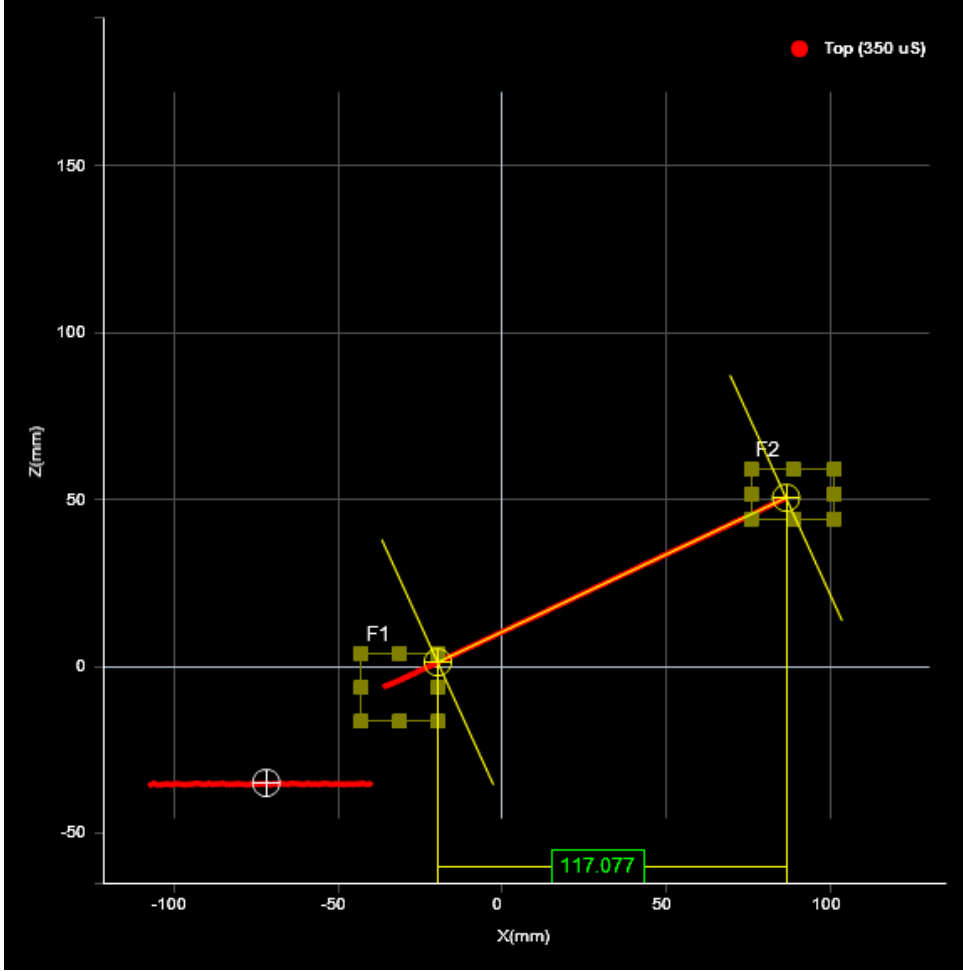

Parameter
Anchoring

X: #3 - Profile Position X

Z: Disabled

Width	<input type="checkbox"/>
Height	<input type="checkbox"/>
Distance	117.077 <input checked="" type="checkbox"/>
Center X	<input type="checkbox"/>
Center Z	<input type="checkbox"/>

Id: 2

Output

Filters ☰

Decision

Min: 110 mm

Max: 125 mm

Anchoring is not required in order to use measurement tools. This is an optional feature that helps make measurements more robust when the position and the height of the target varies from target to target.

Any X or Z measurement can be used as an anchor for a tool.

Several anchors can be created to run in parallel. For example, you could anchor some measurements relative to the left edge of a target at the same time as some other measurements are anchored relative to the right edge of a target.

To anchor a profile tool to a measurement:

1. Place a representative target object in the field of view.
 - In Profile mode*
 - a. Use the **Start** or **Snapshot** button to view live profile data to help position the target.

2. On the **Measure** page, add a suitable tool to act as an anchor.
A suitable tool is one that returns an X, Y, or Z position as a measurement value.
3. Adjust the anchoring tool's settings and measurement region.
You can adjust the measurement region graphically in the data viewer or manually by expanding the **Regions** area.
The position and size of the anchoring tool's measurement regions define the zone within which movement will be tracked.
See *Feature Points* on page 131 for more information on feature types.
4. Add the tool that you want to anchor.
Any tool can be anchored.
5. Adjust the tool and measurement settings, as well as the measurement regions, on a scan of the representative target.
6. Click on the tool's **Anchoring** tab.
7. Choose an anchor from one of the drop-down boxes.
If the sensor is running, the anchored tool's measurement regions are shown in white to indicate the regions are locked to the anchor. The measurement regions of anchored tools cannot be adjusted.
The anchored tool's measurement regions are now tracked and will move with the target's position under the sensor, as long as the anchoring measurement produces a valid measurement value. If the anchoring measurement is invalid, for example, if part moves outside its measurement region, the anchored tool will not show the measurement regions at all and an "Invalid-Anchor" message will be displayed in the tool panel.
8. Verify that the anchored tool works correctly on other scans of targets in which the part has moved slightly.

To remove an anchor from a tool:

1. Click on the anchored tool's Anchoring tab.
Select **Disabled** in the X, Y, or Z drop-down.

Enabling and Disabling Measurements

All of the measurements available in a tool are listed in the measurement list in the **Tools** panel after a tool has been added. To configure a measurement, you must enable it.

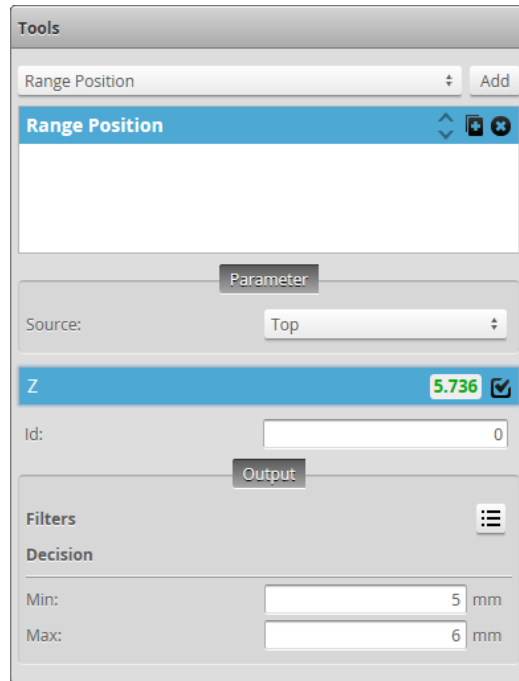

To enable a measurement:

1. Go to the **Scan** page by clicking on the **Scan** icon.
2. Choose Range mode in the **Scan Mode** panel.
If this mode is not selected, tools will not be available in the **Measure** panel.
3. Go to the **Measure** page by clicking on the **Measure** icon.
4. In the measurements list, check the box of the measurement you want to enable.
The measurement will be enabled and selected. The **Output** tab, which contains output settings will be displayed below the measurements list. For some measurements, a **Parameters** tab, which contains measurement-specific parameters, will also be displayed.

To disable a measurement:

1. Go to the **Scan** page by clicking on the **Scan** icon.
2. Choose Range mode in the **Scan Mode** panel.
3. Go to the **Measure** page by clicking on the **Measure** icon.
4. In the measurement list, uncheck the box of the measurement you want to disable.
The measurement will be disabled and the **Output** tab (and the **Parameters** tab if it was available) will be hidden.

Editing Tool, Input, or Output Names

You can change the names of tools you add in Gocator. You can also change the names of their measurements. This allows multiple instances of tools and measurements of the same type to be more

easily distinguished in the Gocator web interface. The measurement name is also referenced by the Script tool.

To change a tool or measurement name:

1. Go to the **Scan** page by clicking on the **Scan** icon.
2. Choose Range mode in the **Scan Mode** panel.
If this mode is not selected, tools will not be available in the **Measure** panel.
3. Go to the **Measure** page by clicking on the **Measure** icon.
4. Do one of the following:
 - **Tool:** In the tool list, double-click the tool name you want to change
 - **Measurement:** In a tool's measurement list, double-click the measurement name you want to change.
5. Type a new name.
6. Press the Tab or Enter key, or click outside the field.
The name will be changed.

Changing a Measurement ID

The measurement ID is used to uniquely identify a measurement in the Gocator protocol or in the SDK. The value **must** be unique among all measurements.

To edit a measurement ID:

1. Go to the **Scan** page by clicking on the **Scan** icon.
2. Choose Range mode in the **Scan Mode** panel.
If this mode is not selected, tools will not be available in the **Measure** panel.
3. Go to the **Measure** page by clicking on the **Measure** icon.
4. In the measurement list, select a measurement.
To select a measurement, it must be enabled. See *Enabling and Disabling Measurements* on page 140 for instructions on how to enable a measurement.
5. Click in the ID field.
6. Type a new ID number.
The value must be unique among all measurements.
7. Press the Tab or Enter key, or click outside the ID field.
The measurement ID will be changed.

Duplicating a Tool

You can quickly create a copy of a previously added tool in Gocator. All settings of the original are copied. This is useful, for example, when you need almost identical tools with only minor variations, such as different Min and Max values.

To duplicate a tool:

1. Go to the **Scan** page by clicking on the **Scan** icon.
2. Choose Range or Profile mode in the **Scan Mode** panel.
If one of these modes is not selected, tools will not be available in the **Measure** panel.
3. Go to the **Measure** page by clicking on the **Measure** icon.
4. In the tool list, click the Duplicate button (📄) of the tool you want to duplicate.
A copy of the tool appears below the original.

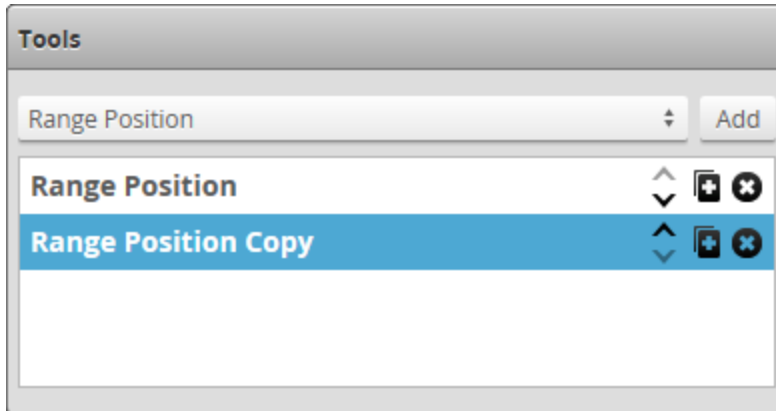

5. Configure the copy as desired and rename it if necessary.
For information on renaming a tool, see *Editing Tool, Input, or Output Names* on page 141.

Removing a Tool

Removing a tool removes all of its associated measurements.

To remove a tool:

1. Go to the **Scan** page by clicking on the **Scan** icon.
2. Choose Range or Profile mode in the **Scan Mode** panel.
If this mode one of these modes is not selected, tools will not be available in the **Measure** panel.
3. Go to the **Measure** page by clicking on the **Measure** icon.
4. In the tool list, click on the Duplicate button (✕) of the tool you want to duplicate.
A copy of the tool appears below the original.

Reordering Tools

When you [add](#) or [duplicate](#) a tool, the tool is added to the bottom of the list in the **Tools** panel. You can reorder tools in the web interface to organize tools more logically. For example, you could group tools that output [geometric features](#) with the tools that use them. Or you could group tools you use as anchors with the tools that use those anchors.

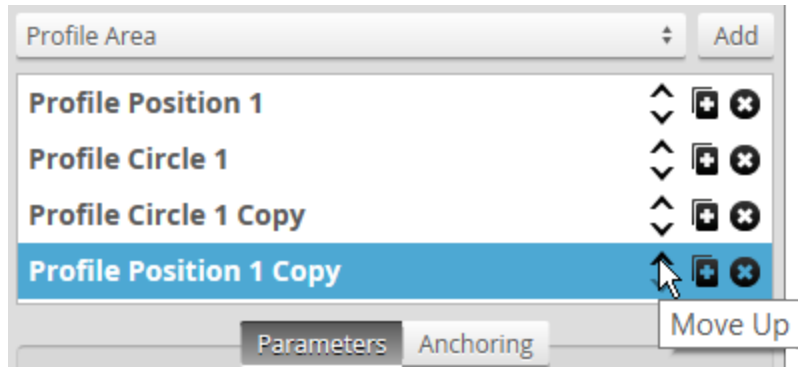

Range Measurement

This section describes the range measurement tools available in the Gocator sensors.

Position

The Position tool finds the Z axis position of the laser range.

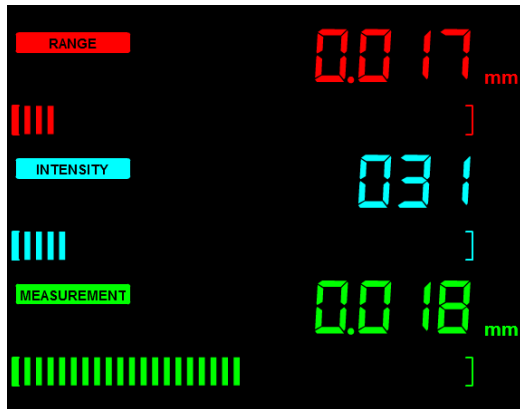

The image shows a software interface for configuring the Position tool. It has a 'Parameter' dropdown menu set to 'Z' with a value of '0.018' and a checkmark. Below this is an 'Id' field with the value '0'. There is an 'Output' button. Under 'Filters', there is a menu icon. Under 'Decision', there are 'Min' and 'Max' fields with values '-1 mm' and '1 mm' respectively.

For information on adding, managing, and removing tools and measurements, as well as detailed descriptions of settings common to most tools, see *Tools Panel* on page 129.

Measurements and Settings

Measurements

Measurement

Position Z

Determines the Z axis position of the laser range.

Illustration

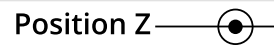

Parameters

Parameter

Source

Description

The sensor, or combination of sensors, that provides data for the tool's measurements. For more information, see *Source* on page 130.

Filters

The filters that are applied to measurement values before they are output. For more information, see *Filters* on page 136.

Decision

The **Max** and **Min** settings define the range that determines whether the measurement tool sends a pass or fail decision to the output. For more information, see *Decisions* on page 134.

Thickness

The Thickness tool determines the difference along the Z axis between two laser ranges.



The settings panel is titled 'Thickness' and is divided into sections. The 'Parameter' section includes 'Source' set to 'Left & Right' and a checked 'Absolute' option. The 'Thickness' value is displayed as '12.581' with a checkmark. The 'Id' field contains the number '1'. The 'Output' section includes a 'Filters' icon. The 'Decision' section has 'Min' set to '12 mm' and 'Max' set to '13 mm'.

The difference can be expressed as an absolute or signed result. The difference is calculated by:

$$\text{Thickness} = \text{Range}_{\text{Main}} - \text{Range}_{\text{Buddy}}$$

For information on adding, managing, and removing tools and measurements, as well as detailed descriptions of settings common to most tools, see *Tools Panel* on page 129.

Measurements and Settings

Measurements

Measurement	Illustration
<p>Thickness</p> <p>Determines the difference (thickness) along the Z axis between two laser ranges.</p>	<p>The diagram shows two horizontal lines representing laser ranges. A vertical double-headed arrow between them is labeled 'Thickness'. Each horizontal line ends with a small circle containing a dot, representing a sensor or measurement point.</p>

Parameters

Parameter	Description
Source	The sensor, or combination of sensors, that provides data for the tool's measurements. For more information, see <i>Source</i> on page 130.
Absolute	Check the Absolute option to select absolute result

Parameter	Description
Filters	The filters that are applied to measurement values before they are output. For more information, see <i>Filters</i> on page 136.
Decision	The Max and Min settings define the range that determines whether the measurement tool sends a pass or fail decision to the output. For more information, see <i>Decisions</i> on page 134.

Script

A Script measurement can be used to program a custom measurement using a simplified C-based syntax. A script measurement can produce multiple measurement values and decisions for the output.

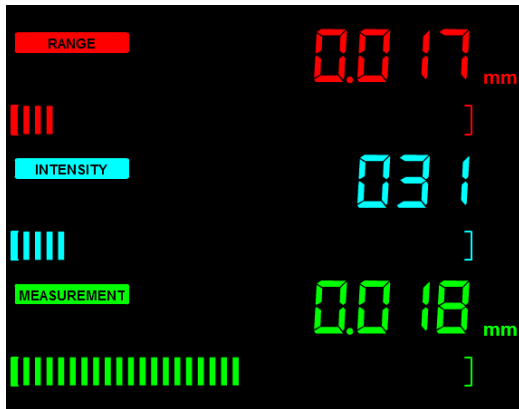

```
Code
1 double PositionZ = Measurement_Value(0);
2
3 if (Measurement_Valid(0))
4 {
5   Output_Set(PositionZ + 10000, 1);
6 }
7 else
8 {
9   Output_Set(0, 0);
10 }
11
```

*Press save button or 'Ctrl+S' to apply change.
Press 'Esc' to exit full screen.

Output:

Output 0

Id:

See *Scripts* on page 228 for more information on the script syntax.

To create or edit a Script measurement:

1. Add a new Script tool or select an existing Script measurement.
2. Edit the script code.
3. Add script outputs using the **Add** button.
For each script output that is added, an index will be added to the **Output** drop-down and a unique ID will be generated.
To remove a script output, click on the button next to it.
4. Click the **Save** button to save the script code.
If there is a mistake in the script syntax, the result will be shown as a "Invalid" with a red border in the data viewer when you run the sensor.
Outputs from multiple measurement tools can be used as inputs to the script. A typical script would take results from other measurement tools using the value and decision function, and output the result using the output function. Stamp information, such as time and encoder stamps, are available in the script, whereas the actual data is not. (The script engine is not powerful enough to process the data itself.) Only one script can be created.

Profile Measurement

This section describes the profile measurement tools available in Gocator sensors.



The Profile Advanced Height tool is not supported on Gocator 1300 sensors. It will however appear in emulator scenarios created from Gocator 1300 sensors.

Area

The Area tool determines the cross-sectional area within a region.

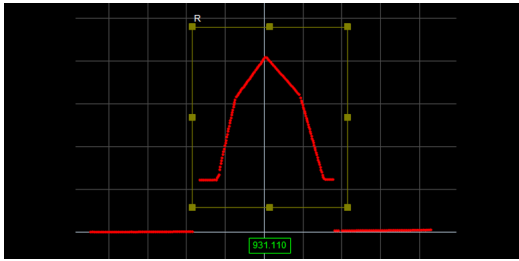





Parameters Anchoring

Source: Top ▾

Type: Object ▾

Baseline: Line ▾

Region  

Line 1 Region ▾  

Measurements Features

Area	931.110	<input checked="" type="checkbox"/>
Centroid X		<input type="checkbox"/>
Centroid Z		<input type="checkbox"/>

ID:

Output

Filters 

Decision

Min:	<input type="text" value="930"/>	mm ²
Max:	<input type="text" value="940"/>	mm ²

Areas are positive in regions where the profile is above the X axis. In contrast, areas are negative in regions where the profile is below the X axis.

For information on adding, managing, and removing tools and measurements, as well as detailed descriptions of settings common to most tools, see *Tools Panel* on page 129.

Measurements, Features, and Settings

Measurements

Measurement

Illustration

Area

Measures the cross-sectional area within a region that is above or below a fitted baseline.

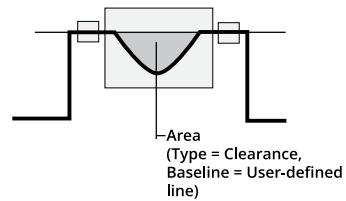
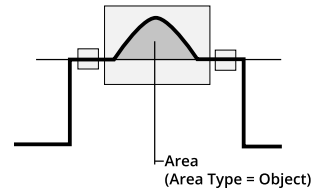

Standalone,
or dual-sensor setup
in Wide orientation

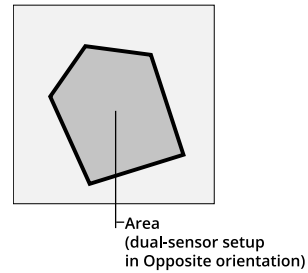
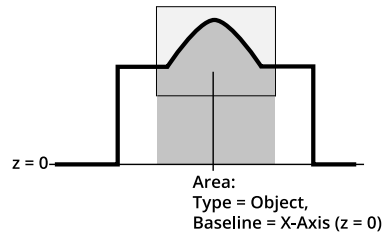

Centroid X

Determines the X position of the centroid of the area.

Centroid Z

Determines the Z position of the centroid of the area.

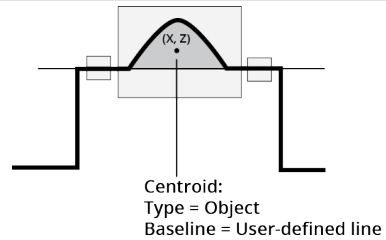

Features

Type

Description

Center Point

The center point of the area.



For more information on geometric features, see *Geometric Features* on page 133.

Parameters

Parameter	Description
Source	The sensor, or combination of sensors, that provides data for the tool's measurements. For more information, see <i>Source</i> on page 130.
Type	Object area type is for convex shapes above the baseline. Regions below the baseline are ignored. Clearance area type is for concave shapes below the baseline. Regions above the baseline are ignored.
Baseline	Baseline is the fit line that represents the line above which (Object clearance type) or below which (Clearance area type) the cross-sectional area is measured. When this parameter is set to Line , you must define a line in the Line parameter. See <i>Fit Lines</i> on page 134 for more information on fit lines. When this parameter is set to X-Axis , the baseline is set to $z = 0$.
Region	The region to which the tool's measurements will apply. For more information, see <i>Regions</i> on page 130.
Line	When Baseline (see above) is set to Line , set this to one of the following: 1 Region or 2 Regions: Lets you set one or two regions whose data the tool will use to fit a line. All Data: The tool uses all of the data in the active area. For more information on regions, see <i>Regions</i> on page 130). For more information on fit lines, see <i>Fit Lines</i> on page 134.
Filters	The filters that are applied to measurement values before they are output. For more information, see <i>Filters</i> on page 136.
Decision	The Max and Min settings define the range that determines whether the measurement tool sends a pass or fail decision to the output. For more information, see <i>Decisions</i> on page 134.

Anchoring

Anchor	Description
X or Z	Lets you choose the X or Z measurement of another tool to use as a positional anchor for this tool.



A measurement *must* be enabled in the other tool for it to be available as an anchor. The anchor measurement should also be properly configured before using it as an anchor.



For more information on anchoring, see *Measurement Anchoring* on page 137.

Bounding Box

The Bounding Box tool provides measurements related to the smallest box that contains the profile (for example, X position, Z position, width, etc.).

The bounding box provides the absolute position from which the Position centroids tools are referenced.



When you use measurement tools on parts, the coordinates returned are relative to the part. You can use the values returned by the Bounding Box tool's "Global" (see below) measurements as an offset in a Gocator script to convert the positional (X or Z) measurements of other measurement tools to [sensor](#) or [system](#) coordinates (depending on whether the sensor is aligned). For more information on Gocator scripts, see *Scripts* on page 228.

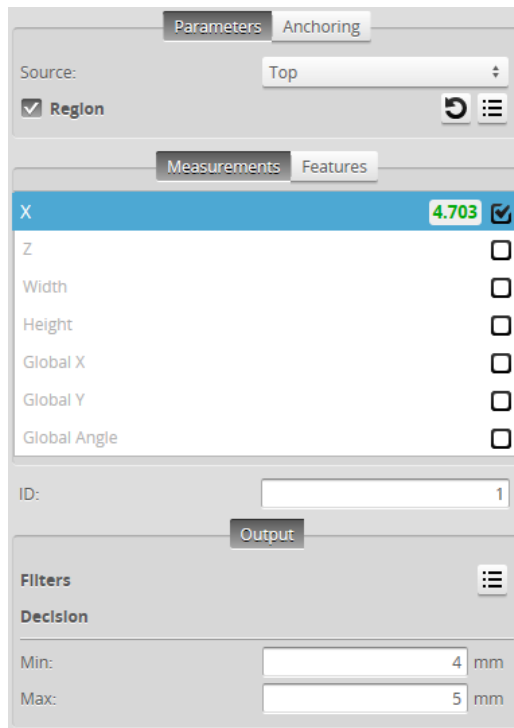
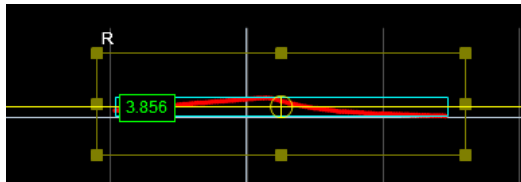

Measurement Panel

For information on adding, managing, and removing tools and measurements, as well as detailed descriptions of settings common to most tools, see *Tools Panel* on page 129.

Measurements, Features, and Settings

Measurements

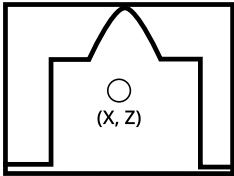
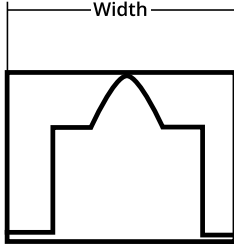
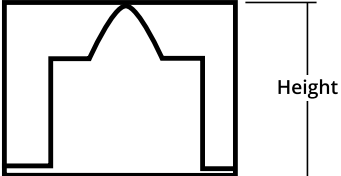
Measurement	Illustration
<p>X</p> <p>Determines the X position of the center of the bounding box that contains the profile.</p> <p>The value returned is relative to the profile.</p>	
<p>Z</p> <p>Determines the Z position of the center of the bounding box that contains the profile.</p> <p>The value returned is relative to the profile.</p>	
<p>Width</p> <p>Determines the width of the bounding box that contains the profile. The width reports the dimension of the box in the direction of the minor axis.</p>	
<p>Height</p> <p>Determines the height (thickness) of the bounding box that contains the profile.</p>	
<p>Global X*</p> <p>This measurement is not intended for use with Gocator 1300 sensors.</p>	
<p>Global Y*</p> <p>This measurement is not intended for use with Gocator 1300 sensors.</p>	
<p>Global Angle*</p> <p>This measurement is not intended for use with Gocator 1300 sensors.</p>	

Features

Type	Description
Center Point	The center point of the bounding box.
Corner Point	The lower left corner of the bounding box.

 For more information on geometric features, see *Geometric Features* on page 133.

Parameters

Parameter	Description
Source	The sensor, or combination of sensors, that provides data for the tool's measurements. For more information, see <i>Source</i> on page 130.
Region	The region to which the tool's measurements will apply. For more information, see <i>Regions</i> on page 130.
Filters	The filters that are applied to measurement values before they are output. For more information, see <i>Filters</i> on page 136.
Decision	The Max and Min settings define the range that determines whether the measurement tool sends a pass or fail decision to the output. For more information, see <i>Decisions</i> on page 134.

Anchoring

Anchor	Description
X or Z	Lets you choose the X or Z measurement of another tool to use as a positional anchor for this tool.



A measurement *must* be enabled in the other tool for it to be available as an anchor. The anchor measurement should also be properly configured before using it as an anchor.



For more information on anchoring, see *Measurement Anchoring* on page 137.

Circle

The Circle tool provides measurements that find the best-fitted circle to a profile and measure various characteristics of the circle.



The tool may be unable to fit a circle to the profile when attempting the fit on a small number of relatively collinear data points.

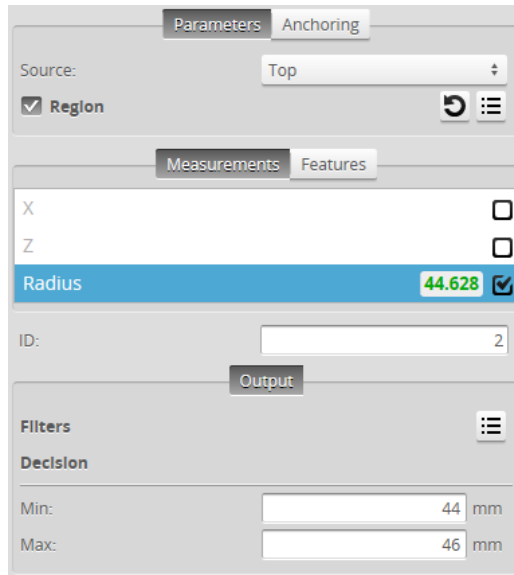
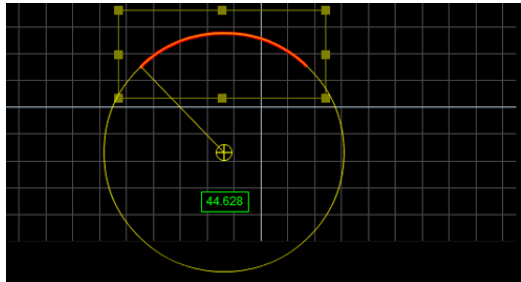

For information on adding, managing, and removing tools and measurements, as well as detailed descriptions of settings common to most tools, see *Tools Panel* on page 129.

Measurements, Features, and Settings

Measurements

Measurement

Illustration

Radius

Measures the radius of the circle.

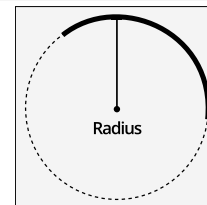

X

Finds the circle center position in the X axis.

Z

Finds the circle center position in the Z axis.

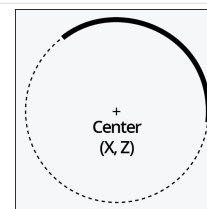

Measurement	Illustration
<p>Standard Deviation</p> <p>Returns the standard deviation of the data points with respect to the fitted circle.</p>	
<p>Min Error</p> <p>Max Error</p> <p>The minimum and maximum error among the data points with respect to the fitted circle.</p>	
<p>Min Error X</p> <p>Min Error Z</p> <p>The X and Z position of the minimum error.</p>	
<p>Max Error X</p> <p>Max Error Z</p> <p>The X and Z position of the maximum error.</p>	

Features

Type	Description
Center Point	The center point of the fitted circle.

 For more information on geometric features, see *Geometric Features* on page 133.

Parameters

Parameter	Description
Source	The sensor, or combination of sensors, that provides data for the tool's measurements. For more information, see <i>Source</i> on page 130.
Region	The region to which the tool's measurements will apply. For more information, see <i>Regions</i> on page 130.
Filters	The filters that are applied to measurement values before they are output. For more information, see <i>Filters</i> on page 136.
Decision	The Max and Min settings define the range that determines whether the measurement tool sends a pass or fail decision to the output. For more information, see <i>Decisions</i> on page 134.

Anchoring

Anchor	Description
X or Z	Lets you choose the X or Z measurement of another tool to use as a positional anchor for this tool.



A measurement *must* be enabled in the other tool for it to be available as an anchor. The anchor measurement should also be properly configured before using it as an anchor.



For more information on anchoring, see *Measurement Anchoring* on page 137.

Circle Radii



This tool is not supported on A and B revision Gocator 2100 and 2300 sensors. However, it is supported on any accelerated sensors (PC or GoMax), including these models, and will appear in emulator scenarios created using these sensors.

The Profile Circle Radii tool lets you measure radii and diameters at specified angle steps, given a specified center point. The tool draws rays from the center point and returns radii or diameter measurements for each ray.

For example, in the following scan of an exhaust pipe by a four-sensor system, the tool is showing a radius measurement at 70 degrees that indicates a dent in the pipe. The tool also provides settings to compensate for missing data and for rough surfaces or noise.

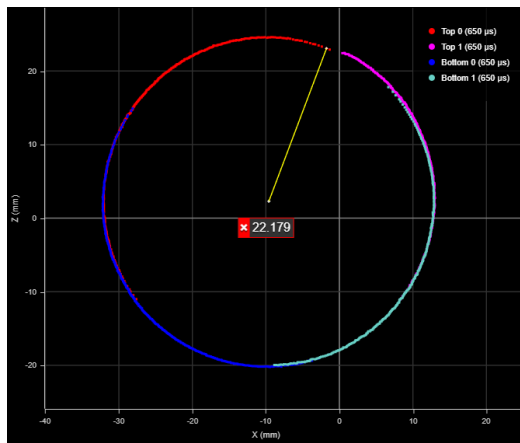

Parameters Anchoring

Source: Top & Bottom

Use Region

Center Selection: Feature Input

Center: Profile Circle/Center Point

Angle Start: 0 deg

Angle Step: 10 deg

Tolerance: 1 deg

Averaging: 0

Output: Radius

Selection: Custom

Measurements Data

Radius at 0.000	22.448	<input checked="" type="checkbox"/>
Radius at 10.000	22.593	<input checked="" type="checkbox"/>
Radius at 20.000	22.668	<input checked="" type="checkbox"/>
Radius at 30.000	22.700	<input checked="" type="checkbox"/>
Radius at 40.000	22.772	<input checked="" type="checkbox"/>
Radius at 50.000	22.679	<input checked="" type="checkbox"/>
Radius at 60.000	22.697	<input checked="" type="checkbox"/>
Radius at 70.000	22.179	<input checked="" type="checkbox"/>
Radius at 80.000	22.233	<input checked="" type="checkbox"/>

For information on adding, managing, and removing tools and measurements, as well as detailed descriptions of settings common to most tools, see *Tools Panel* on page 129.

Measurements, Features, and Settings

Measurements

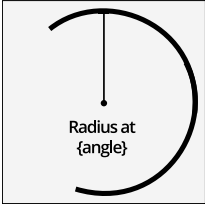
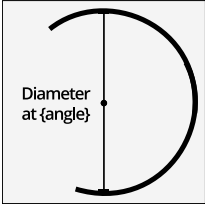
Measurement	Illustration
<p>Radius at {angle}</p> <p>Returns the radius at {angle}.</p>	
<p>Diameter at {angle}</p> <p>Returns the diameter at {angle}.</p>	

Data

Type	Description
Points	An array of the points at the end of the rays.

Parameters

Parameter	Description
Source	The sensor, or combination of sensors, that provides data for the tool's measurements. For more information, see <i>Source</i> on page 130.
Use Region	Indicates whether the tool uses a user-defined region. If this option is not checked, the tool uses data from the entire active area.
Region	The region to which the tool's measurements will apply. For more information, see <i>Regions</i> on page 130.
Center Selection	The source for the point geometric feature the tool uses as a center point. One of the following: Bounding Box – Uses the center of the bounding box that encloses the scan data selected in Source . If Use Region is enabled, the tool places a bounding box only around the data in the region. If Use Region is disabled, the tool places a bounding box around all scan data; this will include any outliers in the bounding box, which could produce an undesired center point. Feature Input – A point geometric feature provided by another tool, such as the center point from a Circle tool.
Center	The point geometric feature coming from another tool that the Circle Radii tool uses as the center point from which rays are drawn to search for data points. The parameter is only available when Center Selection is set to Feature Input .

Parameter	Description
-----------	-------------

Angle Start	Angle Start: The angle at which ray steps start.
-------------	---

Angle Step	Angle Step: The angle step in degrees.
------------	---

The following shows how these settings work together:

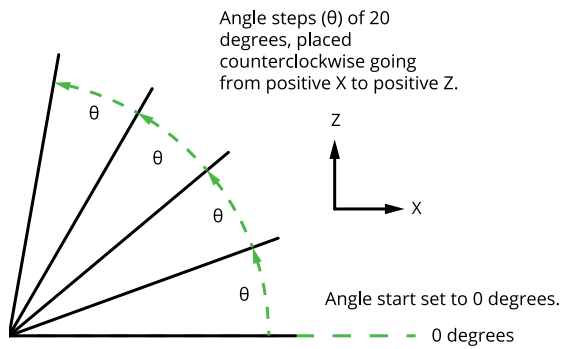

The tool searches for a data point at each angle step and returns the radius from the center point or the diameter.

Tolerance	If no data point is found at the angle step, the tool searches within the specified number of degrees to each side of the step to find a data point. Useful to compensate for gaps in the data.
-----------	---

Tolerance: Number of degrees (θ) to each side of the angle step within which the tool searches for data points.

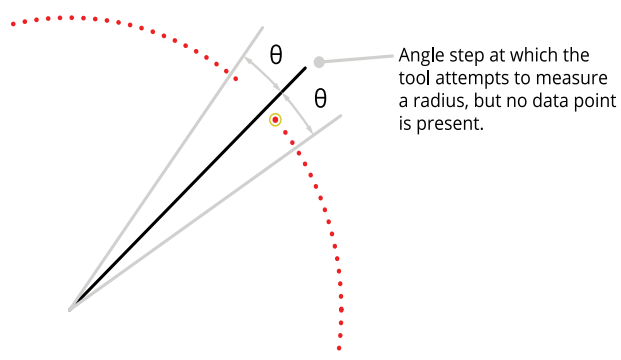

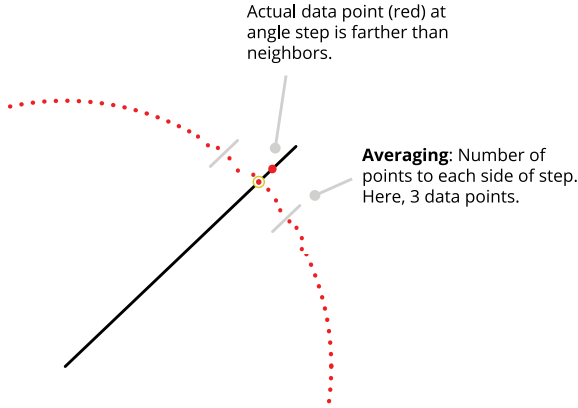

The graphic above shows how the tool searches to each side of the angle step until it finds a data point (circled and in yellow).

Parameter	Description
Averaging	<p>The number of data points to each side of the point the tool uses to average. Use this to compensate for noise or rough surfaces.</p>  <p>The graphic above shows how the tool averages the data point at the angle step with the number of data points specified in Averaging to each side of the angle step, replacing the original data point with the average (circled and in yellow).</p>
Output	Selects whether to output radius, diameter, or both at each step.
Selection	Lets you quickly enable or disable all measurements.
Filters	The filters that are applied to measurement values before they are output. For more information, see <i>Filters</i> on page 136.
Decision	The Max and Min settings define the range that determines whether the measurement tool sends a pass or fail decision to the output. For more information, see <i>Decisions</i> on page 134.

Anchoring

Anchor	Description
X or Z	Lets you choose the X or Z measurement of another tool to use as a positional anchor for this tool.

 A measurement *must* be enabled in the other tool for it to be available as an anchor. The anchor measurement should also be properly configured before using it as an anchor.

 For more information on anchoring, see *Measurement Anchoring* on page 137.

Closed Area

The Closed Area tool determines the cross-sectional area within a region using point cloud data from a dual- or multi-sensor system.

The tool is intended for use with roughly circular shaped profiles, or profiles that do not contain excessive concavity. The tool renders a polygon corresponding to the profile in the data viewer. Use this polygon to decide whether the tool can correctly calculate an acceptable representation of the profile. Minor gaps in the profile are permitted; the size of these gaps is configurable.

When the tool is used in conjunction with a script tool, you can calculate the volume of a target; for more information on the Script tool, see *Script* on page 214.

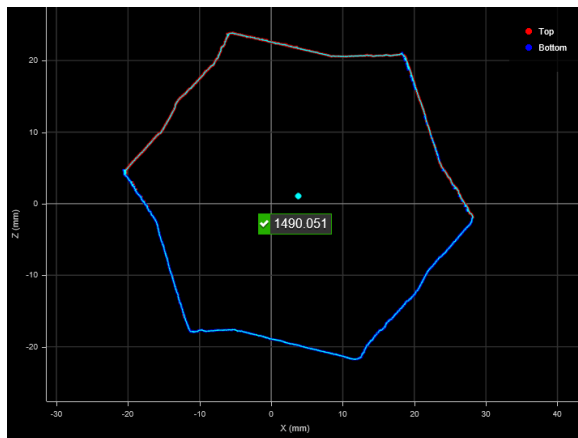

For information on adding, managing, and removing tools and measurements, as well as detailed descriptions of settings common to most tools, see *Tools Panel* on page 129.

Measurements and Settings

Measurements

Measurement	Illustration
Closed Area Measures the cross-sectional area within a region using data from a dual- or multi-sensor system.	

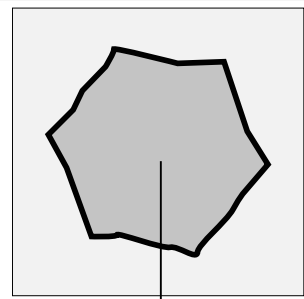

Parameters

Parameter	Description
Source	The sensor, or combination of sensors, that provides data for the tool's measurements. For more information, see <i>Source</i> on page 130. For this tool, you should set this parameter to Top and Bottom .
Use Region	Indicates whether the tool uses a user-defined region. If this option is not checked, the tool uses data from the entire active area.
Region	The region to which the tool's measurements will apply. For more information, see <i>Regions</i> on page 130.
Use Max Gap	Indicates whether the tool uses the Max Gap setting (see below).
Max Gap	The maximum gap allowed between any two profile points on the contour of the target, in millimeters. In the following illustration of a profile, if the gap were greater than the value set in Max Gap , the tool would return an invalid value.

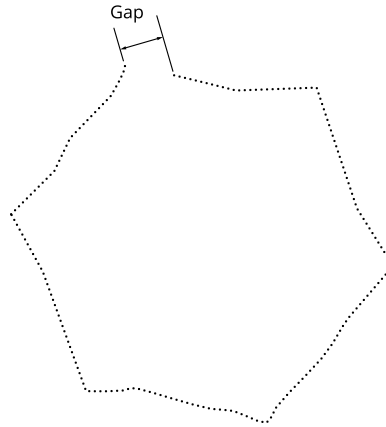

Parameter	Description
-----------	-------------

Sample Spacing	<p>The angle interval around the center of the profile the tool uses to calculate area. Enabling this setting and setting a value can increase the tool's performance.</p> <p>In the following image, the spacing is set to 1 degree. The polygon calculated from the profile points, which is then used to calculate the area, is simplified, increasing performance but reducing accuracy.</p>
----------------	--

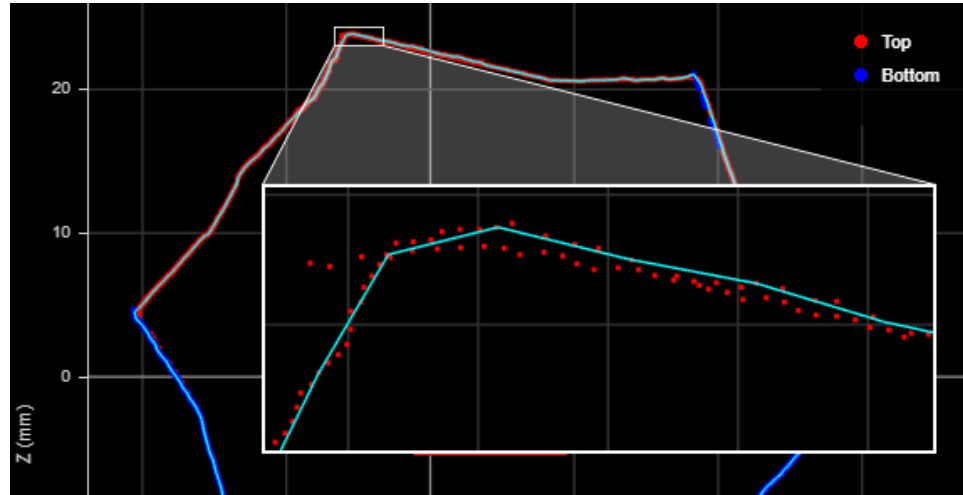

In the following image, **Sampling Spacing** is set to 0. Accuracy is increased, but performance is reduced.

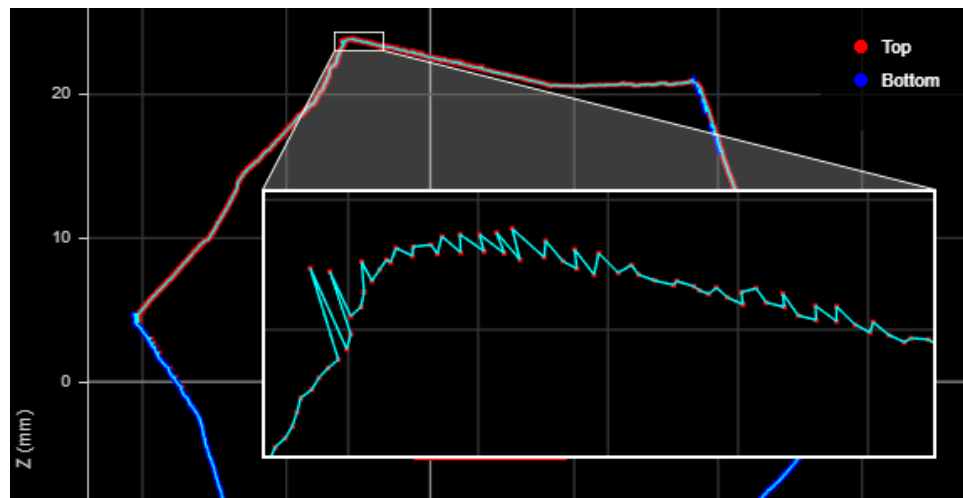

If you set the value to 0, the tool uses the smallest angle permitted internally by the sampling engine.

Filters	The filters that are applied to measurement values before they are output. For more information, see <i>Filters</i> on page 136.
---------	--

Decision	The Max and Min settings define the range that determines whether the measurement tool sends a pass or fail decision to the output. For more information, see <i>Decisions</i> on page 134.
----------	---

Anchoring

Anchor	Description
X or Z	Lets you choose the X or Z measurement of another tool to use as a positional anchor for this tool.



A measurement *must* be enabled in the other tool for it to be available as an anchor. The anchor measurement should also be properly configured before using it as an anchor.



For more information on anchoring, see *Measurement Anchoring* on page 137.

Dimension

The Dimension tool provides Width, Height, Distance, Center X, and Center Z measurements.

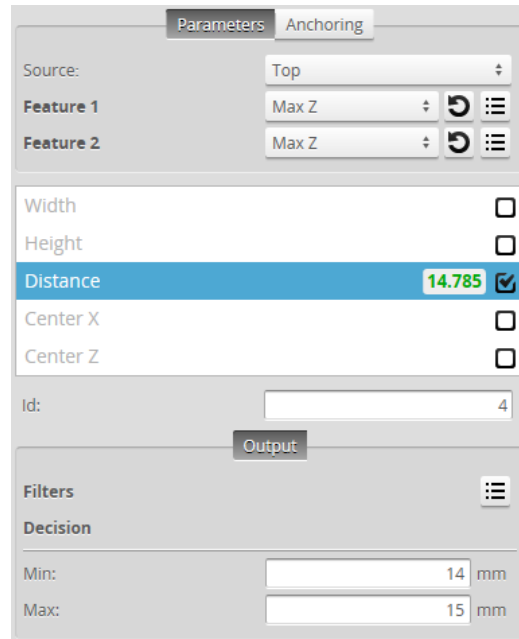
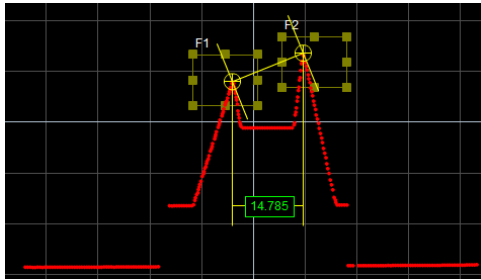

For information on adding, managing, and removing tools and measurements, as well as detailed descriptions of settings common to most tools, see *Tools Panel* on page 129.

Measurements and Settings

Measurements

Measurement

Illustration

Width

Determines the difference along the X axis between two feature points.

The difference can be calculated as an absolute or signed result. The difference is calculated by:

$$\text{Width} = \text{Feature 2}_{X \text{ position}} - \text{Feature 1}_{X \text{ position}}$$

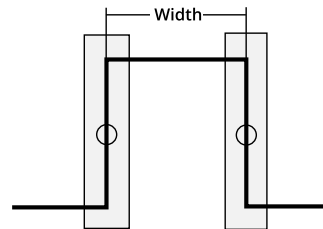

Height

Determines the difference along the Z axis between two feature points.

The difference can be expressed as an absolute or signed result. The difference is calculated by:

$$\text{Height} = \text{Feature 2}_{Z \text{ position}} - \text{Feature 1}_{Z \text{ position}}$$

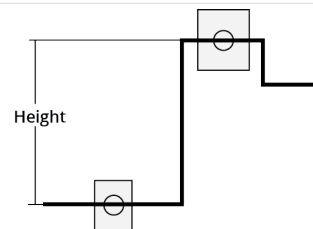

Measurement**Illustration****Distance**

Determines the direct, Euclidean distance between two feature points.

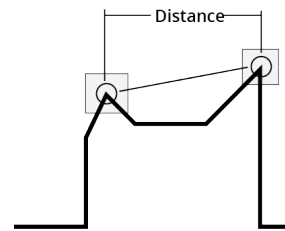
**Center X**

Finds the average location of two features and measures the X axis position of the average location

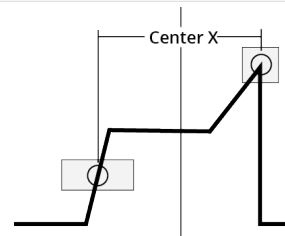
**Center Z**

Finds the average location of two features and measures the Z axis position of the average location.

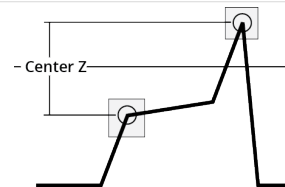

Parameters**Parameter****Description**

Source

The sensor, or combination of sensors, that provides data for the tool's measurements. For more information, see *Source* on page 130.

Parameter	Description
Feature 1 Feature 2	<p>The Feature 1 and Feature 2 settings represent the two features the tool uses to perform measurements. For each, one of the following:</p> <ul style="list-style-type: none"> • Max Z • Min Z • Max X • Min X • Corner • Average • Rising Edge • Falling Edge • Any Edge • Top Corner • Bottom Corner • Left Corner • Right Corner • Median <p>To set the region of a feature, adjust it graphically in the data viewer, or expand the feature using the expand button (☰) and enter the values in the fields. For more information on regions, see <i>Regions</i> on page 130.</p>
Absolute <i>(Width and Height measurements only)</i>	Determines if the result will be expressed as an absolute or a signed value.
Filters	The filters that are applied to measurement values before they are output. For more information, see <i>Filters</i> on page 136.
Decision	The Max and Min settings define the range that determines whether the measurement tool sends a pass or fail decision to the output. For more information, see <i>Decisions</i> on page 134.

Anchoring

Anchor	Description
X or Z	Lets you choose the X or Z measurement of another tool to use as a positional anchor for this tool.

 A measurement *must* be enabled in the other tool for it to be available as an anchor. The anchor measurement should also be properly configured before using it as an anchor.

 For more information on anchoring, see *Measurement Anchoring* on page 137.

Edge

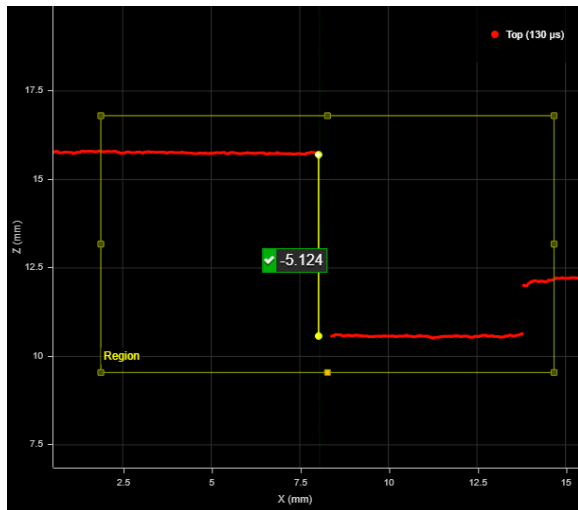

The Profile Edge tool finds an edge on a profile, searching from left to right. The tool's settings help fit the edge point when multiple potential edges are in the region of interest. After the tool locates an edge, the position (X and Z) of the center of the step and the step height can be returned as measurements.

The tool can also generate a point geometric feature corresponding to the center of the step that Feature tools can take as input for measurement. For more information on Feature tools, see *Feature Measurement* on page 215.



Parameters Anchoring

Source: Top

Region  

Use Region

Selection Type: Best

Step Direction: Falling

Step Threshold: 0 mm

Step Smoothing: 0 mm

Step Width: 0 mm

Max Gap: 1 mm

Include Null Edges

Null Fill Value: 0 mm

Show Detail

Measurements Features

X	8.030	<input checked="" type="checkbox"/>
Z	13.139	<input checked="" type="checkbox"/>
Step Height	-5.124	<input checked="" type="checkbox"/>

ID: 1

Output

Filters 

Decision

Min: -6 mm

Max: 5 mm

For information on adding, managing, and removing tools and measurements, as well as detailed descriptions of settings common to most tools, see *Tools Panel* on page 129.

Measurements, Features, and Settings

Measurements

Measurement

X

Z

These measurements return the X and Z position of the edge point, respectively. The edge point is located half-way between the upper and lower data points of the step.

Step Height

Returns the height of the step on the profile.

Features

Type	Description
Edge Center Point	The edge point.



For more information on geometric features, see *Geometric Features* on page 133.

Parameters

Parameter	Description
Source	The sensor, or combination of sensors, that provides data for the tool's measurements. For more information, see <i>Source</i> on page 130.
Selection Type	Determines which step the tool uses when there are multiple steps in the profile. An edge point is placed the chosen step. Steps must satisfy the tool's Step Threshold and Step Direction settings. Best: Selects the greatest step on the profile. First: Selects the first step on the profile. Last: Selects the last step on the profile.

Parameter	Description
-----------	-------------

Step Threshold	The minimum step accepted as an edge candidate. Steps on the profile are treated as absolute values when compared to this setting.
----------------	--

In the following profile, with **Step Threshold** set to 1.7 (and **Selection Type** set to Last), the tool accepts the step to the right, with a step of -1.873 mm, because it is above the step threshold.

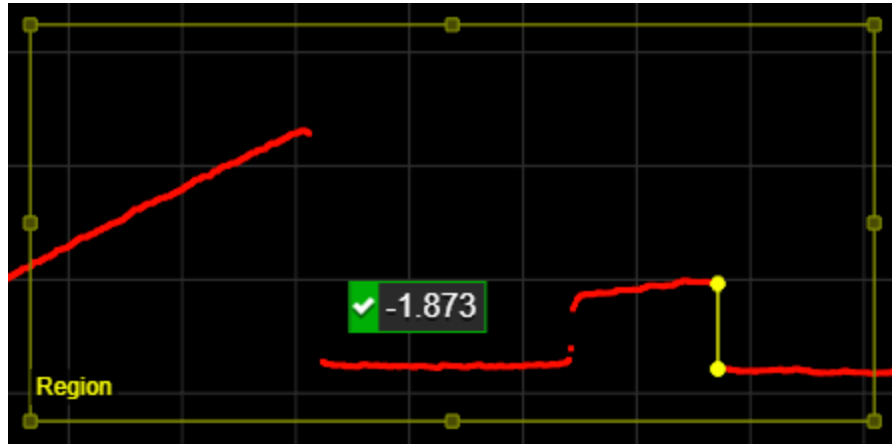

In the following, when **Step Threshold** is increased to 1.9, the tool excludes the falling step to the right, because it is no longer above the step threshold, and instead uses the step to the left.

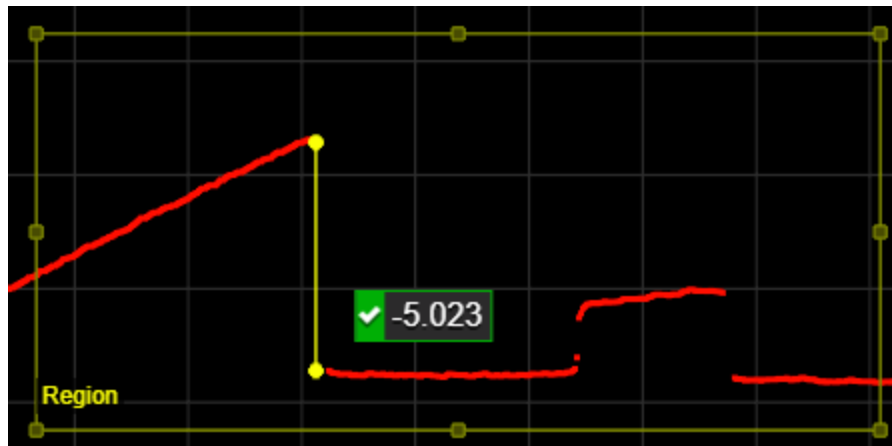

Step Direction	Determines whether the expected step rises or falls, moving left to right, along the profile. Either Rising , Falling , or Rising or Falling .
----------------	---

Step Smoothing	The size of the (moving) window along the profile used to calculate an average for each data point on the profile. The setting is useful for averaging out noise.
----------------	---

If **Step Smoothing** is set to 0, no averaging is performed.

Parameter

Description

Step Width

The distance, along a path profile, separating the points the tool uses to find steps on a profile. In the following, a step width of 5.5 mm causes the tool to consider profile points that distance apart as steps. Consequently, the curved portion of the profile is not used to measure the step.

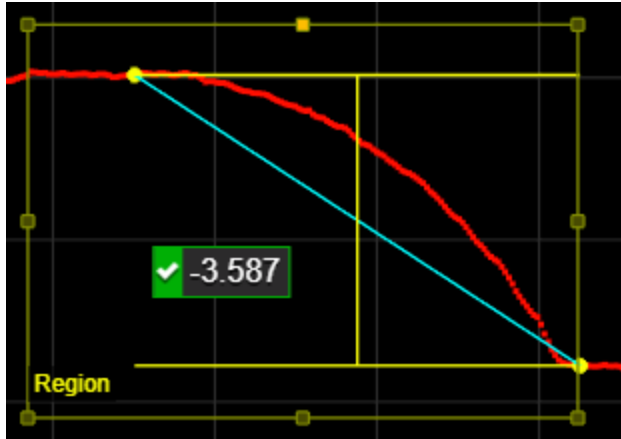

The setting is useful when you must detect a slope as an edge, rather than a sharply defined edge: setting **Step Width** to a value greater than the width of the edge ensures that the tool measures the height difference between the flat regions on either side of the edge. As a result, the height of the step is accurately measured, and the edge is correctly located.

Setting **Step Width** wider than necessary can reduce the precision of edge location.

Max Gap

Fills in regions of missing data caused by an occlusion near the desired edge. Use this setting when continuity on the target is expected. When **Max Gap** is set to a non-zero value, the tool holds and extends the last data point on the low side next to an edge across a gap of null points, up to the distance specified in **Max Gap**.

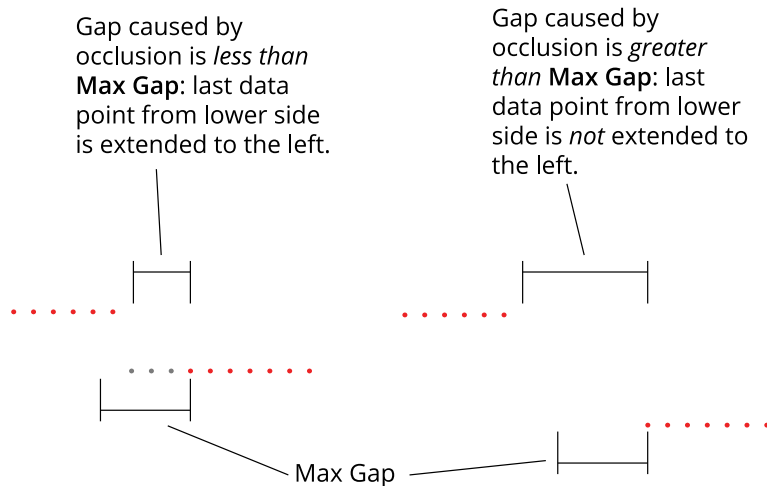



The tool uses data points "filled in" by **Max Gap** before data points filled in by **Null Fill Value** (see below).

Parameter	Description
Include Null Edges	<p>Indicates whether null points (points where no height value is available, due to dropouts or regions outside of the measurement range) are filled with the value in Null Fill Value as a general “background level.”</p> <div style="border: 1px solid black; padding: 5px;"> <p> To find an edges next null points, you must use either this option and an appropriate value in Null Fill Value or Max Gap. Otherwise, only edges within areas of contiguous data will be detected.</p> </div>
Null Fill Value	<p>The height value (in mm) used to replace null points when Include Null Edges is enabled.</p> <p>If both Null Fill Value and Max Gap fill in null points at the same position, the tool uses the value extended by Max Gap, regardless of the value of Null Fill Value.</p>
Show Detail	When disabled, reduces what is indicated in the data viewer.
Filters	The filters that are applied to measurement values before they are output. For more information, see <i>Filters</i> on page 136.
Decision	The Max and Min settings define the range that determines whether the measurement tool sends a pass or fail decision to the output. For more information, see <i>Decisions</i> on page 134.

Anchoring

Anchor	Description
X, Y, or Z	Lets you choose the X, Y, or Z measurement of another tool to use as a positional anchor for this tool.

 A measurement *must* be enabled in the other tool for it to be available as an anchor. The anchor measurement should also be properly configured before using it as an anchor.

 For more information on anchoring, see *Measurement Anchoring* on page 137.

Groove

The Groove tool provides measurements of V-shape, U-shape, or open-shape grooves.

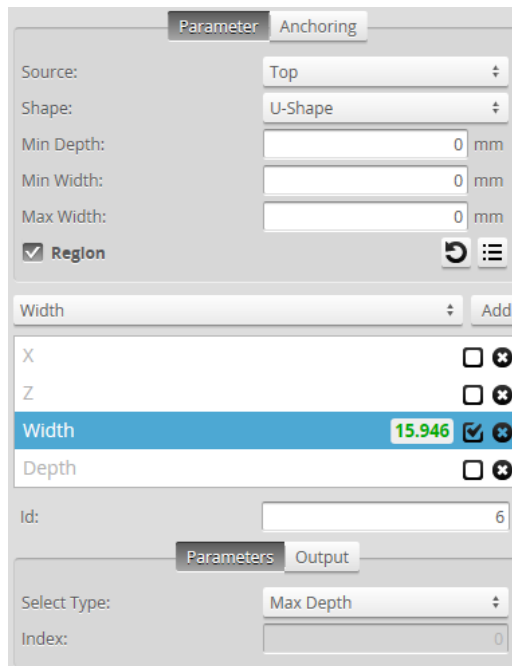
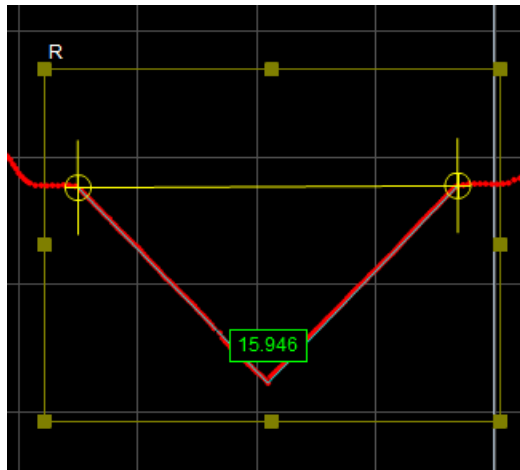

The Groove tool uses a complex feature-locating algorithm to find a groove and then return measurements. See "Groove Algorithm" in the *Gocator Measurement Tool Technical Manual* for a detailed explanation of the algorithm. The behavior of the algorithm can be adjusted by changing the parameters in the measurement panel.

The Groove tool lets you add multiple measurements of the same type to receive measurements and set decisions for multiple grooves. Multiple measurements are added by using the drop-down above the list of measurements and clicking on the **Add** button.

For example, if a target has three grooves, by adding two measurements, choosing **Index From The Left** in the **Select Type** setting of those measurements, and providing values of 0 and 2 in the **Index** setting of the measurements, respectively, the Groove tool will return measurements and decisions for the first and third grooves.

For information on adding, managing, and removing tools and measurements, as well as detailed descriptions of settings common to most tools, see *Tools Panel* on page 129.

Measurements, Features, and Settings

Measurements

Measurement

Illustration

Width

Measures the width of a groove.

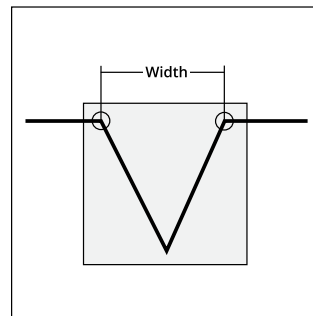
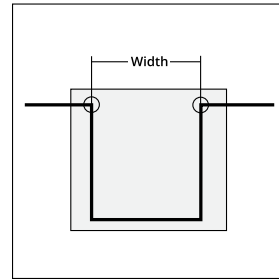

Depth

Measures the depth of a groove as the maximum perpendicular distance from a line connecting the edge points of the groove.

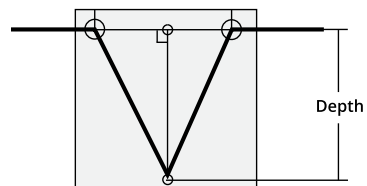
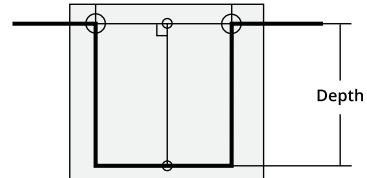

Measurement**Illustration****X**

Measures the X position of the bottom of a groove.

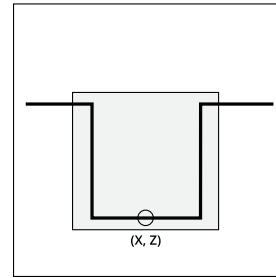
**Z**

Measures the Z position of the bottom of a groove.

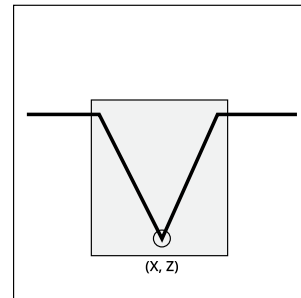

Parameters**Parameter****Description**

Source

The sensor, or combination of sensors, that provides data for the tool's measurements. For more information, see *Source* on page 130.

Shape

Shape of the groove

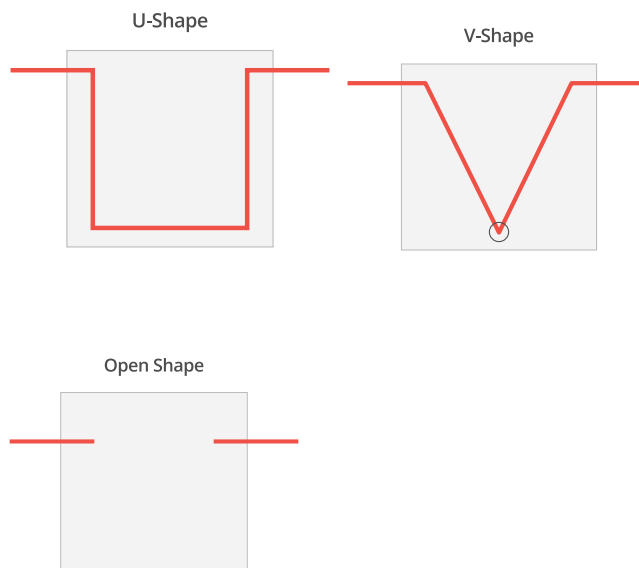

Parameter	Description
Min Depth	Minimum depth for a groove to be considered valid.
Min Width	Minimum width for a groove to be considered valid. The width is the distance between the groove corners.
Max Width	Maximum width of a groove to be considered valid. If set to 0, the maximum is set to the width of the measurement area.
Region	The measurement region defines the region in which to search for the groove. For a stable measurement, the measurement region should be large enough to cover some data on the left and right sides of the groove.

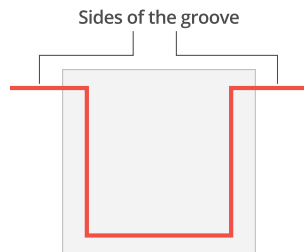

For more information on regions, see *Regions* on page 130.

Location <i>(Groove X and Groove Z measurements only)</i>	Specifies the location type to return Bottom - Groove bottom. For a U-shape and open-shape groove, the X position is at the centroid of the groove. For a V-shape groove, the X position is at the intersection of lines fitted to the left and right sides of the groove. See algorithm section below for more details. Left - Groove's left corner. Right - Groove's right corner.
Select Type	Specifies how a groove is selected when there are multiple grooves within the measurement area. Maximum Depth - Groove with maximum depth. Index from The Left - 0-based groove index, counting from left to right Index from the Right - 0-based groove index, counting from right to left.
Index	0-based groove index.
Filters	The filters that are applied to measurement values before they are output. For more information, see <i>Filters</i> on page 136.
Decision	The Max and Min settings define the range that determines whether the measurement tool sends a pass or fail decision to the output. For more information, see <i>Decisions</i> on page 134.

Anchoring

Anchor	Description
X or Z	Lets you choose the X or Z measurement of another tool to use as a positional anchor for this tool.



A measurement *must* be enabled in the other tool for it to be available as an anchor. The anchor measurement should also be properly configured before using it as an anchor.



For more information on anchoring, see *Measurement Anchoring* on page 137.

Intersect

The Intersect tool determines intersect points and angles.

The Intersect tool's measurements require two fit lines, one of which is a reference line set to the X axis ($z = 0$), the Z axis ($x = 0$), or a user-defined line.

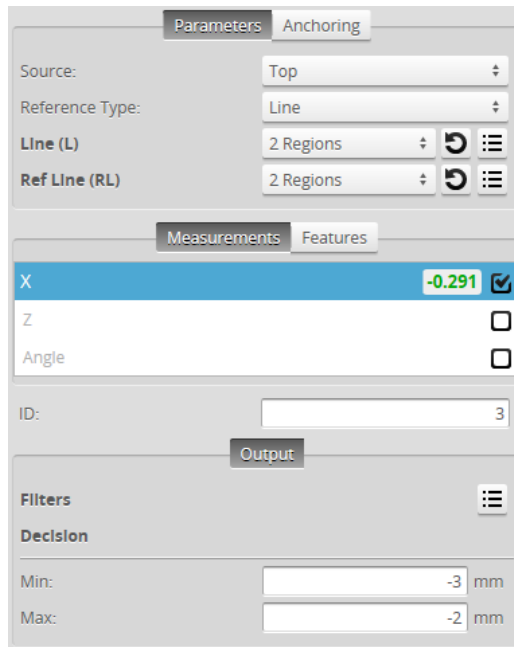

For information on adding, managing, and removing tools and measurements, as well as detailed descriptions of settings common to most tools, see *Tools Panel* on page 129.

Measurements, Features, and Settings

Measurements

Measurement

X

Finds the intersection between two fitted lines and measures the X axis position of the intersection point.

Illustration

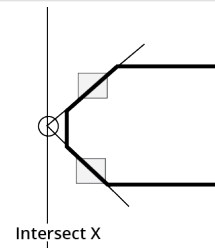

Measurement**Illustration****Z**

Finds the intersection between two fitted lines and measures the Z axis position of the intersection point.

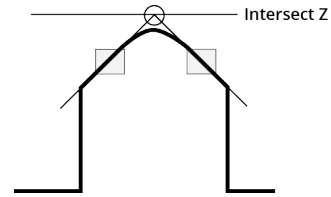
**Angle**

Finds the angle subtended by two fitted lines.

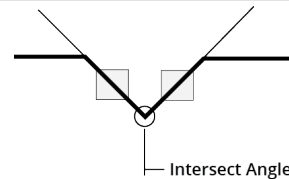

Features**Type****Description**

Intersect Point

The point of intersection.

Line

The intersect line.

Base Line

The base line.



For more information on geometric features, see *Geometric Features* on page 133.

Parameters**Parameter****Description**

Source

The sensor, or combination of sensors, that provides data for the tool's measurements. For more information, see *Source* on page 130.

Reference Type

Determines the type of the reference line.

X-Axis: The reference line is set to the X axis.

Z-Axis: The reference line is set to the Z axis

Line: The reference line is defined manually using the **Ref Line** parameter. One or two regions can be used to define the line.

Line

You can use one or two fit areas for the fit line. To set the region (or regions) of the fit line, adjust it graphically in the data viewer, or expand the feature using the expand button (⋮) and enter the values in the fields. For more information on regions, see *Regions* on page 130.

For more information on fit lines, see *Fit Lines* on page 134.

Parameter	Description
Ref Line	Used to define the reference line when Line is selected in the Reference Type parameter. To set the region (or regions) of the reference line, adjust it graphically in the data viewer, or expand the feature using the expand button (☰) and enter the values in the fields. For more information on regions, see <i>Regions</i> on page 130. For more information on fit lines, see <i>Fit Lines</i> on page 134.
Angle Range <i>(Angle measurement only)</i>	Determines the angle range. The options are: -90 – 90 0 – 180
Filters	The filters that are applied to measurement values before they are output. For more information, see <i>Filters</i> on page 136.
Decision	The Max and Min settings define the range that determines whether the measurement tool sends a pass or fail decision to the output. For more information, see <i>Decisions</i> on page 134.

Anchoring

Anchor	Description
X or Z	Lets you choose the X or Z measurement of another tool to use as a positional anchor for this tool.

 A measurement *must* be enabled in the other tool for it to be available as an anchor. The anchor measurement should also be properly configured before using it as an anchor.

 For more information on anchoring, see *Measurement Anchoring* on page 137.

Line

The Line tool fits a line to the profile and measures the deviations from the best-fitted line. The sensor compares the measurement value with the values in **Min** and **Max** to yield a decision. For more information on decisions, see *Decisions* on page 134.

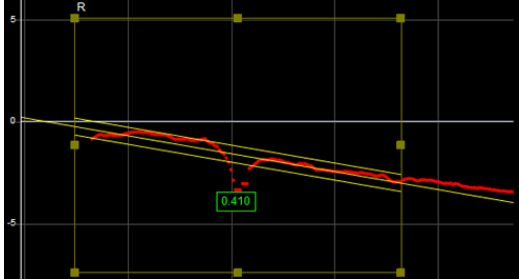

Parameters Anchoring

Source: Top

Region

X: -25.63 mm

Z: -22.355 mm

Width: 52.404 mm

Height: 52.404 mm

Fitting Regions All Data

Measurements Features

Standard Deviation	0.410	<input checked="" type="checkbox"/>
Min Error		<input type="checkbox"/>
Max Error		<input type="checkbox"/>
Percentile		<input type="checkbox"/>
Offset		<input type="checkbox"/>
Angle		<input type="checkbox"/>
Min Error X		<input type="checkbox"/>
Min Error Z		<input type="checkbox"/>
Max Error X		<input type="checkbox"/>
Max Error Z		<input type="checkbox"/>

ID: 4

Output

Filters

Decision

Min: 0 mm

Max: 1 mm

For information on adding, managing, and removing tools and measurements, as well as detailed descriptions of settings common to most tools, see *Tools Panel* on page 129.

Measurements, Features, and Settings

Measurements

Measurement

Illustration

Standard Deviation

Finds the best-fitted line and measures the standard deviation of the data points from the line.

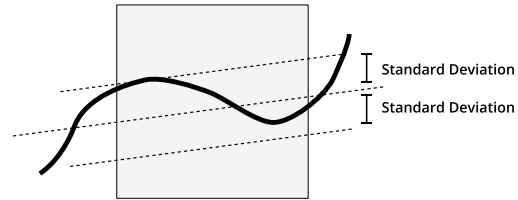

Min Error

Finds the best-fitted line and measures the minimum error from the line (the maximum distance below the line).

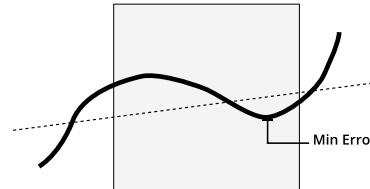

Max Error

Finds the best-fitted line and measures the maximum error from the line (the maximum distance above the line).

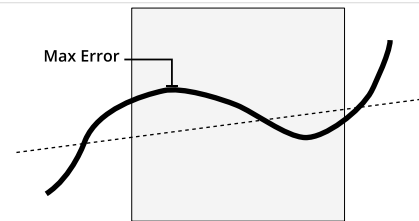

Percentile

Finds the best-fitted line and measures the range (in Z) that covers a percentage of points around the line.

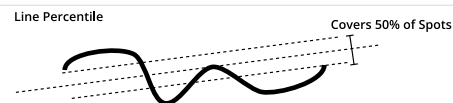

Offset

Finds the best-fitted line and returns the intersection point between that line and the Z axis.

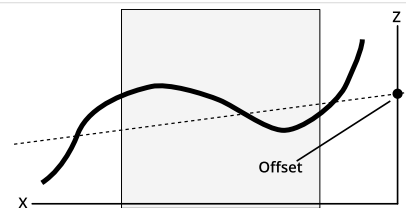

Angle

Finds the best-fitted line and returns the angle relative to the X axis.

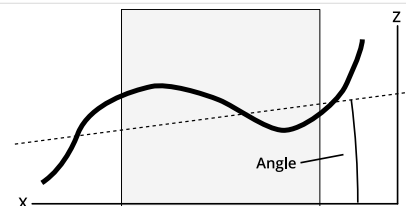

Min Error X

Min Error Z

Finds the best-fitted line and returns the X or Z position of the minimum error from the line (the maximum distance below the line).

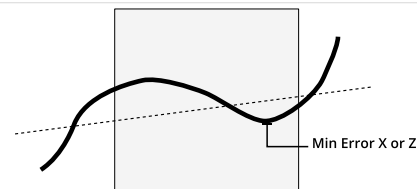

Measurement

Max Error X

Max Error Z

Finds the best-fitted line and returns the X or Z position of the maximum error from the line (the maximum distance above the line).

Illustration

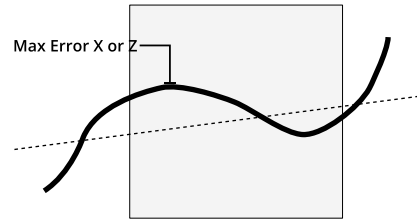

Features

Type

Description

Line

The fitted line.

Error Min Point

The point of minimum error.

Error Max Point

The point of maximum error.



For more information on geometric features, see *Geometric Features* on page 133.

Parameters

Parameter

Description

Source

The sensor, or combination of sensors, that provides data for the tool's measurements. For more information, see *Source* on page 130.

Region

The region to which the tool's measurements will apply. For more information, see *Regions* on page 130.

Fitting Regions

Determines which data Gocator uses to *fit the line* over the profile.

When **Fitting Regions** is enabled, Gocator uses the data indicated by one of the following options:

- **All Data:** All of the data in the profile is used to fit the line.
- **1 Region:** Data from a fitting region you define in the data viewer is used to fit the line.
- **2 Regions:** Data from two fitting regions you define is used to fit the line.

When **Fitting Regions** is disabled, to fit the line, Gocator uses the measurement region if **Region** is enabled, or the entire profile if **Region** is disabled.

When **Fitting Regions** is enabled and **1 Region** or **2 Regions** is selected, you can set the region (or regions) graphically in the data viewer, or you can expand the feature using the expand button () and enter the values in the fields. For more information on regions, see *Regions* on page 130.

Parameter	Description
Percent <i>(Percentile measurement only)</i>	The specified percentage of points around the best-fitted line.
Filters	The filters that are applied to measurement values before they are output. For more information, see <i>Filters</i> on page 136.
Decision	The Max and Min settings define the range that determines whether the measurement tool sends a pass or fail decision to the output. For more information, see <i>Decisions</i> on page 134.

Anchoring

Anchor	Description
X or Z	Lets you choose the X or Z measurement of another tool to use as a positional anchor for this tool.

 A measurement *must* be enabled in the other tool for it to be available as an anchor. The anchor measurement should also be properly configured before using it as an anchor.

 For more information on anchoring, see *Measurement Anchoring* on page 137.

Line Advanced



This tool is not supported on A and B revision Gocator 2100 and 2300 sensors. However, it is supported on any accelerated sensors (PC or GoMax), including these models, and will appear in emulator scenarios created using these sensors.

Like the Profile Line tool, the Profile Line Advanced tool fits a line to a profile and measures the deviations from the best-fitted line. Additionally, this version of the tool provides two “roughness parameter” measurements: Ra and Rz. Note that the region-related parameters have been reorganized to make the tool easier to use. The sensor compares the measurement value with the values in **Min** and **Max** to yield a decision. For more information on decisions, see *Decisions* on page 134.



If you do not need the roughness parameters, LMI currently recommends using the Profile Line tool (see *Line* on page 184).



Set **Fitting Method** to **Simple** to cause the tool to behave like the older Profile Line tool.

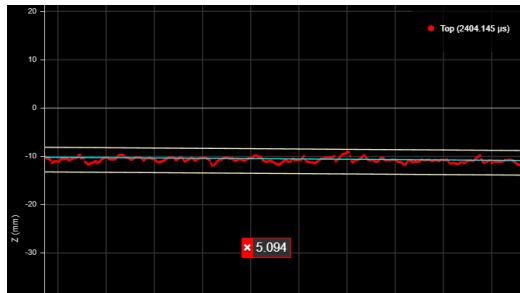

Parameters	Anchoring
Source:	Top
Region:	Combined Fitting & Meas...
Region	
Fitting Method:	Robust
Outlier Percentile:	30 %
Measurement Percentage:	50 %

Measurements	Features
Standard Deviation	Invalid
Min Error	<input type="checkbox"/>
Max Error	<input type="checkbox"/>
Percentile	<input type="checkbox"/>
Offset	<input type="checkbox"/>
Angle	<input type="checkbox"/>
Min Error X	<input type="checkbox"/>
Min Error Z	<input type="checkbox"/>
Max Error X	<input type="checkbox"/>
Max Error Z	<input type="checkbox"/>
Ra	<input type="checkbox"/>
Rz	<input type="checkbox"/>

For information on adding, managing, and removing tools and measurements, as well as detailed descriptions of settings common to most tools, see *Tools Panel* on page 129.

Measurements, Features, and Settings

Measurements

Measurement

Illustration

Standard Deviation

Finds the best-fitted line and measures the standard deviation of the data points from the line.

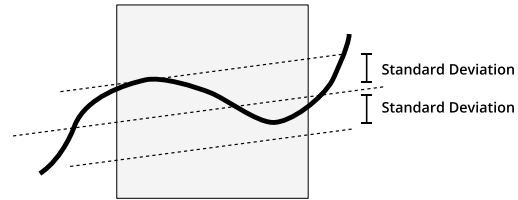

Min Error

Finds the best-fitted line and measures the minimum error from the line (the maximum distance below the line).

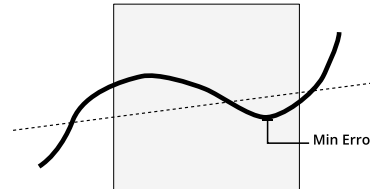

Max Error

Finds the best-fitted line and measures the maximum error from the line (the maximum distance above the line).

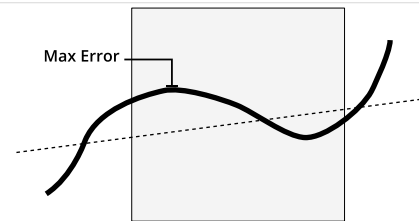

Percentile

Finds the best-fitted line and measures the range (in Z) that covers a percentage of points around the line.

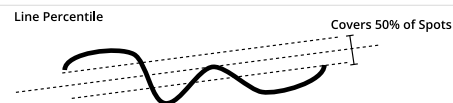

Offset

Finds the best-fitted line and returns the intersection point between that line and the Z axis.

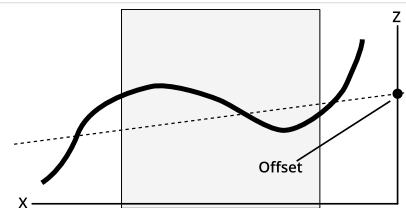

Angle

Finds the best-fitted line and returns the angle relative to the X axis.

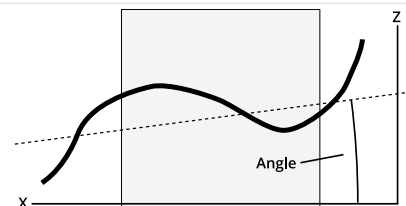

Min Error X

Min Error Z

Finds the best-fitted line and returns the X or Z position of the minimum error from the line (the maximum distance below the line).

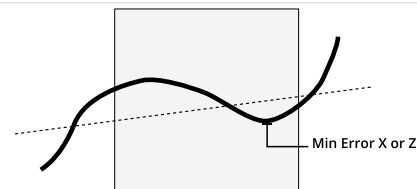

Measurement**Illustration****Max Error X****Max Error Z**

Finds the best-fitted line and returns the X or Z position of the maximum error from the line (the maximum distance above the line).

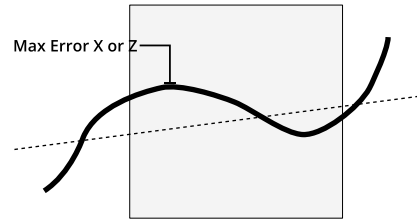
**Ra**

Returns the roughness average of the profile data.

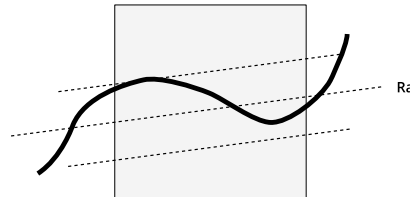
**Rz**

Returns the average maximum height of the profile data.

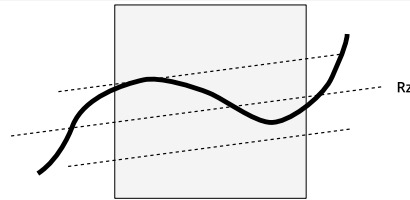

Features**Type****Description**

Line

The fitted line.

Error Min Point

The point of minimum error.

Error Max Point

The point of maximum error.



For more information on geometric features, see *Geometric Features* on page 133.

Parameters**Parameter****Description**

Source

The sensor, or combination of sensors, that provides data for the tool's measurements. For more information, see *Source* on page 130.

Parameter**Description**

Region

Whether the fitting and measurement regions are combined or separate (or not used). One of the following:

None

The tool uses the entire profile to fit the line and perform measurements.

Combined Fitting & Measurement

The tool uses a single, user-defined region to fit the line and in which it performs measurements. In the following image,

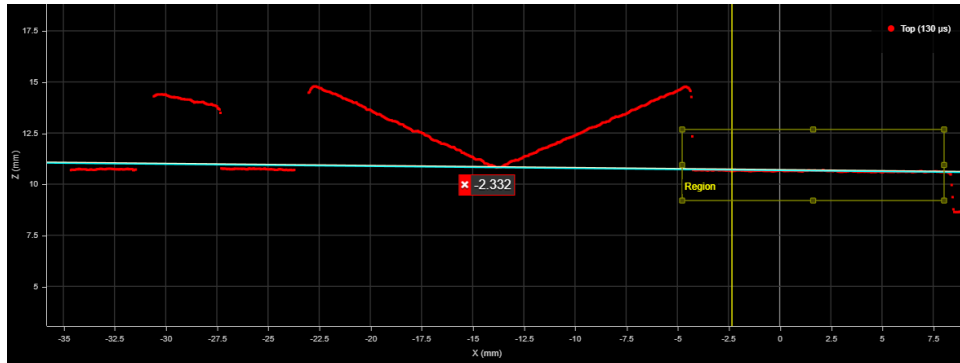
**Separate Fitting & Measurement**

The tool uses one or two regions to fit the line, and a single, separate region in which it performs measurements.

In the following image, the tools uses a single region to the left to fit the line, and performs measurements in the measurement region to the right:

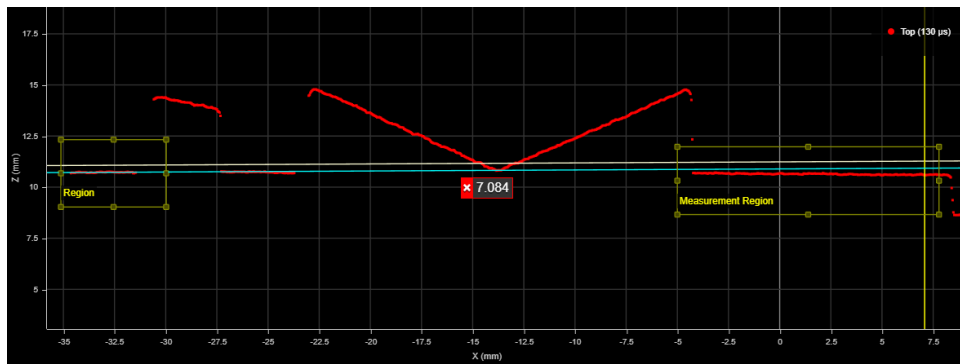

In the following image, the uses two regions to the left to fit the line, and performs measurements in the measurement region to the right:

Parameter	Description
-----------	-------------

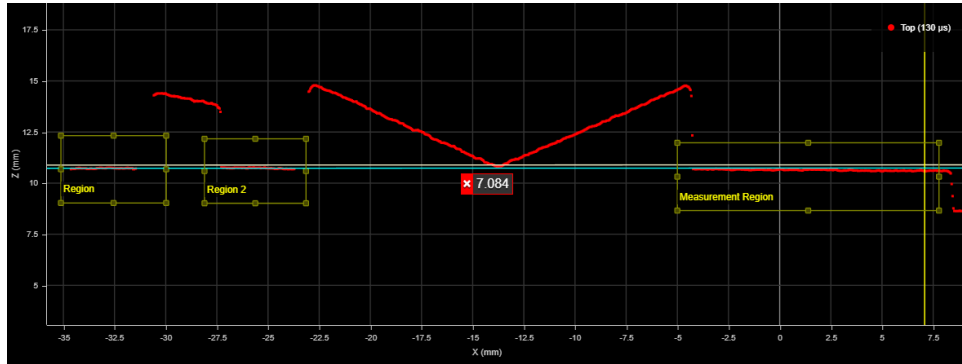

Region	These settings contain parameters to define the position and size of the fitting and measurement regions.
Region 2	
Measurement Region	

(for region definition)

Fitting Method	Determines how the tool fits the line to the data. One of the following:
----------------	--

Simple

Uses a less accurate but faster line-fitting method. Use this setting to cause the tool to behave like Profile Line.

Robust

An iterative line-fitting method that removes points and attempts to fit a line until only one-third of the original profile data points is left. More accurate but takes longer.

Outlier Percentile	Indicates the number of outlier points to be removed overall during line fitting. Adjust this value based on how much noise is present in the profile.
--------------------	--

Only displayed when **Method** is set to **Robust**.

Measurement Percentage	The specified percentage of points around the best-fitted line that the Percentile measurement uses.
------------------------	--

(Percentile measurement only)

Filters	The filters that are applied to measurement values before they are output. For more information, see <i>Filters</i> on page 136.
---------	--

Decision	The Max and Min settings define the range that determines whether the measurement tool sends a pass or fail decision to the output. For more information, see <i>Decisions</i> on page 134.
----------	---

Anchoring

Anchor	Description
--------	-------------

X or Z	Lets you choose the X or Z measurement of another tool to use as a positional anchor for this tool.
--------	---



A measurement *must* be enabled in the other tool for it to be available as an anchor. The anchor measurement should also be properly configured before using it as an anchor.



For more information on anchoring, see *Measurement Anchoring* on page 137.

Panel

The Panel tool provides Gap and Flush measurements.

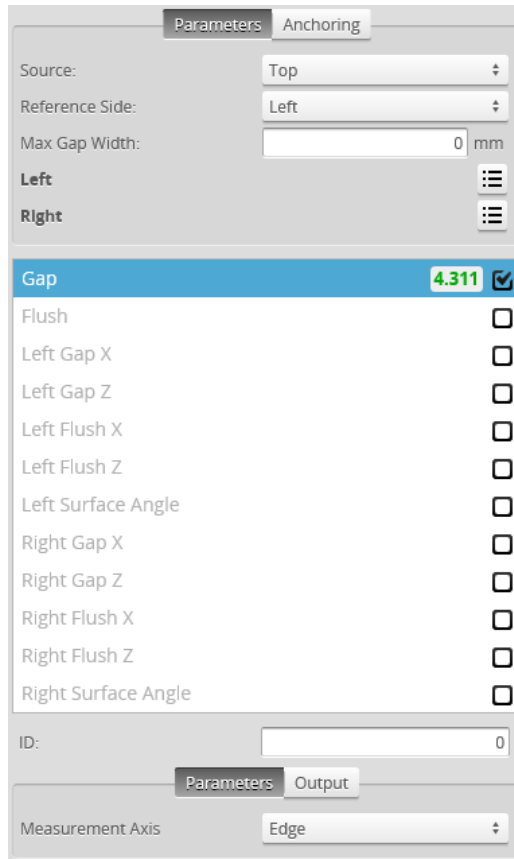
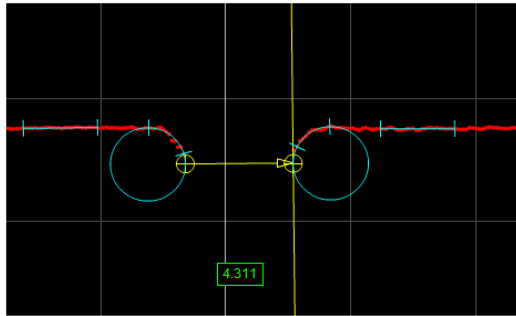

The Panel tool uses a complex feature-locating algorithm to find the gap or calculate flushness and return measurements. The behavior of the algorithm can be adjusted by changing the parameters in the measurement panel. See "Gap and Flush Algorithm" in the *Gocator Measurement Tool Technical Manual* for a detailed explanation of the algorithm.



You must make sure that there are enough data points to define the edge in the profile, by properly setting up exposure, etc. If not, the algorithm will not function.

For information on adding, managing, and removing tools and measurements, as well as detailed descriptions of settings common to most tools, see *Tools Panel* on page 129.

Measurements

Measurement

Illustration

Gap

Measures the distance between two surfaces. The surface edges can be curved or sharp.

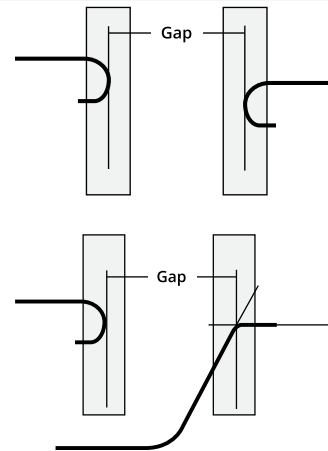

Flush

Measures the flushness between two surfaces. The surface edges can be curved or sharp.

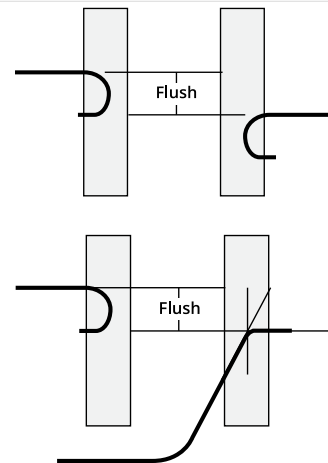

Left Gap X

Returns the X position of the edge feature on the left side used to measure the gap.

Left Gap Z

Returns the Z position of the edge feature on the left side used to measure the gap.

Left Flush X

Returns the X position of the feature on the left side used to measure flushness.

Left Flush Z

Returns the Z position of the feature on the left side used to measure flushness.

Left Surface Angle

The angle of the left side surface relative to the X axis.

Measurement	Illustration
<p>Right Gap X</p> <p>Returns the X position of the edge feature on the right side used to measure the gap.</p>	
<p>Right Gap Z</p> <p>Returns the Z position of the edge feature on the right side used to measure the gap.</p>	
<p>Right Flush X</p> <p>Returns the X position of the feature on the right side used to measure flushness.</p>	
<p>Right Flush Z</p> <p>Returns the Z position of the feature on the right side used to measure flushness.</p>	
<p>Right Surface Angle</p> <p>The angle of the right side surface relative to the X axis.</p>	

Parameters

Parameter	Description
Source	The sensor, or combination of sensors, that provides data for the tool's measurements. For more information, see <i>Source</i> on page 130.
Reference SideDirection	Defines the side used to calculate the measurement axis (see below) rounded corner.
Max Gap Width	The maximum width of the gap. Allows the tool to filter gaps greater than the expected width. This can be used to single out the correct gap when there are multiple gaps in the field of view.
Measurement Axis <i>Gap measurement only</i>	<p>Defines the direction that the gap is calculated, in relation to the reference side (see above).</p> <p>Surface: In the direction of the fitted surface line of the reference surface.</p> <p>Edge: In the direction perpendicular to the edge of the reference surface.</p> <p>Distance: The Cartesian distance between the two feature locations.</p>
Absolute <i>Flush measurement only</i>	When enabled, returns an absolute value rather than a signed value.
Filters	The filters that are applied to measurement values before they are output. For more information, see <i>Filters</i> on page 136.
Decision	The Max and Min settings define the range that determines whether the measurement tool sends a pass or fail decision to the output. For more information, see <i>Decisions</i> on page 134.

Left/Right SideEdge Parameters

Parameter	Description
Max Void Width	The maximum allowed width of missing data caused by occlusion or data dropout.
Min Depth	Defines the minimum depth before an opening could be considered to have a potential edge. The depth is the perpendicular distance from the fitted surface line.
Surface Width	The width of the surface area in which data is used to form the fitted surface line. This value should be as large as the surface allows.
Surface Offset	The distance between the edge region and the surface region. Setting a small value allows the edge within a tighter region to be detected. However, the measurement repeatability could be affected if the data from the edge are considered as part of the surface region (or vice versa). A rule of thumb is to set Surface Offset equal to Nominal Radius .
Nominal Radius	The radius of the curve edge that the tool uses to locate the edge region.
Edge Angle	A point on the best fit circle to be used to calculate the feature point. The selected point is on the circumference at the specified angle from the start of the edge region. The angle is measured from the axis perpendicular to the fitted surface line.
Edge Type	Defines the type of feature point to use for the edge (Corner or Tangent). A tangent edge point is the point selected based on the defined Edge Angle. A corner edge point is the intersect point between the fitted surface line and a edge line formed by interpolating the points at and after the tangent within the edge region.
Region	The region to which the tool's measurements will apply. For more information, see <i>Regions</i> on page 130.

Anchoring

Anchor	Description
X or Z	Lets you choose the X or Z measurement of another tool to use as a positional anchor for this tool.

 A measurement *must* be enabled in the other tool for it to be available as an anchor. The anchor measurement should also be properly configured before using it as an anchor.

 For more information on anchoring, see *Measurement Anchoring* on page 137.

Position

The Position tool finds the X or Z axis position of a feature point. The feature type must be specified and is one of the following: Max Z, Min Z, Max X, Min X, Corner, Average (the mean X and Z of the data points), Rising Edge, Falling Edge, Any Edge, Top Corner, Bottom Corner, Left Corner, Right Corner, or Median (median X and Z of the data points).

For information on adding, managing, and removing tools and measurements, as well as detailed descriptions of settings common to most tools, see *Tools Panel* on page 129.

Measurements, Features, and Settings

Measurements

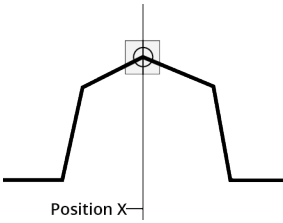
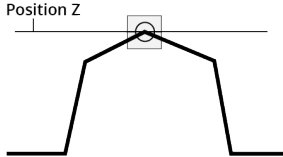
Measurement	Illustration
X Finds the position of a feature on the X axis.	 A line graph showing a peak. A vertical line passes through the peak, and a horizontal line extends from the intersection to the left, labeled "Position X". A small square and circle are at the peak.
Z Finds the position of a feature on the Z axis.	 A line graph showing a peak. A horizontal line passes through the peak, and a vertical line extends from the intersection to the left, labeled "Position Z". A small square and circle are at the peak.

Features

Type	Description
Point	The returned position.

 For more information on geometric features, see *Geometric Features* on page 133.

Parameters

Parameter	Description
Source	The sensor, or combination of sensors, that provides data for the tool's measurements. For more information, see <i>Source</i> on page 130.

Parameter	Description
Feature	<p>The feature the tool uses for its measurements. One of the following:</p> <ul style="list-style-type: none"> • Max Z • Min Z • Max X • Min X • Corner • Average • Rising Edge • Falling Edge • Any Edge • Top Corner • Bottom Corner • Left Corner • Right Corner • Median <p>To set the region of a feature, adjust it graphically in the data viewer, or expand the feature using the expand button (☰) and enter the values in the fields. For more information on regions, see <i>Regions</i> on page 130.</p>
Filters	<p>The filters that are applied to measurement values before they are output. For more information, see <i>Filters</i> on page 136.</p>
Decision	<p>The Max and Min settings define the range that determines whether the measurement tool sends a pass or fail decision to the output. For more information, see <i>Decisions</i> on page 134.</p>

Anchoring

Anchor	Description
X or Z	<p>Lets you choose the X or Z measurement of another tool to use as a positional anchor for this tool.</p>

 A measurement *must* be enabled in the other tool for it to be available as an anchor. The anchor measurement should also be properly configured before using it as an anchor.

 For more information on anchoring, see *Measurement Anchoring* on page 137.

Round Corner

The Round Corner tool measures corners with a radius, returning the position of the edge of the corner and the angle of adjacent surface with respect to the X axis.

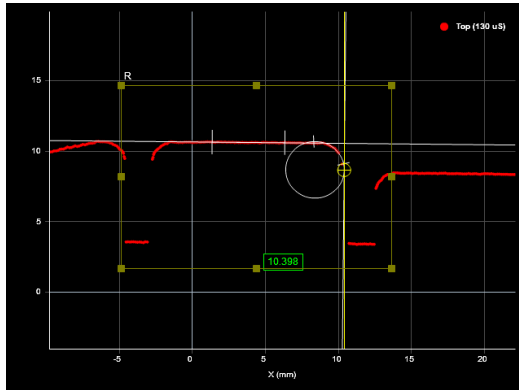

Parameters Anchoring

Source: Top

Reference Direction: From the Left

Edge

Max Void Width: 0 mm

Min Depth: 0 mm

Surface Width: 5 mm

Surface Offset: 2 mm

Nominal Radius: 2 mm

Edge Angle: 90°

Edge Type: Tangent

Region

Measurements Features

X	10.398	<input checked="" type="checkbox"/>
Z		<input type="checkbox"/>
Angle		<input type="checkbox"/>

ID: 0

Output

Filters

Decision

Min: 10 mm

Max: 11 mm

For information on adding, managing, and removing tools and measurements, as well as detailed descriptions of settings common to most tools, see *Tools Panel* on page 129.

The Round Corner tool uses a complex feature-locating algorithm to find the edge and return measurements. The behavior of the algorithm can be adjusted by changing the parameters in the measurement panel. See "Gap and Flush Algorithm" in the *Gocator Measurement Tool Technical Manual* for a detailed explanation of the algorithm.



You must make sure that there are enough data points to define the edge (proper exposure, etc.). If not, the algorithm will not function.

Measurements

Measurement

Illustration

X

Measures the X position of the location where the tangent touches the edge, or intersect of the tangent and the line fitted to the surface used by the measurement (see **Reference Side**, below).

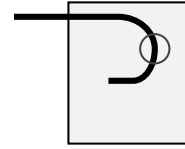

Z

Measures the Z position of the location where the tangent touches the edge, or intersect of the tangent and the line fitted to the surface used by the measurement (see **Reference Side**, below).

Angle

Measures the angle of the line fitted to the surface next to the corner (see **Reference Side**, below), with respect to the x-axis. Left edge angles are from -90 to 90. Right edge angles are from 90 to 270.

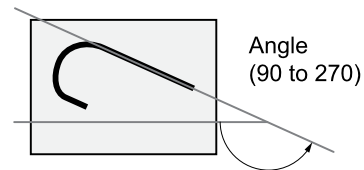
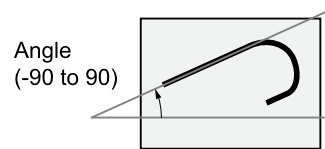

Features

Type

Description

Edge Point

The position of the edge.

Radius Center Point

The center of the radius.



For more information on geometric features, see *Geometric Features* on page 133.

Parameters

Parameter	Description
Source	The sensor, or combination of sensors, that provides data for the tool's measurements. For more information, see <i>Source</i> on page 130.
Reference Direction	Defines the side used to calculate the rounded corner.
Max Gap Width	The maximum width of the gap. Allows the tool to filter gaps greater than the expected width. This can be used to single out the correct gap when there are multiple gaps in the field of view.
Filters	The filters that are applied to measurement values before they are output. For more information, see <i>Filters</i> on page 136.
Decision	The Max and Min settings define the range that determines whether the measurement tool sends a pass or fail decision to the output. For more information, see <i>Decisions</i> on page 134.

Edge Parameters

Parameter	Description
Max Void Width	The maximum allowed width of missing data caused by occlusion or data dropout.
Min Depth	Defines the minimum depth before an opening could be considered to have a potential edge. The depth is the perpendicular distance from the fitted surface line.
Surface Width	The width of the surface area in which data is used to form the fitted surface line. This value should be as large as the surface allows.
Surface Offset	The distance between the edge region and the surface region. Setting a small value allows the edge within a tighter region to be detected. However, the measurement repeatability could be affected if the data from the edge are considered as part of the surface region (or vice versa). A rule of thumb is to set Surface Offset equal to Nominal Radius .
Nominal Radius	The radius of the curve edge that the tool uses to locate the edge region.
Edge Angle	A point on the best fit circle to be used to calculate the feature point. The selected point is on the circumference at the specified angle from the start of the edge region. The angle is measured from the axis perpendicular to the fitted surface line.
Edge Type	Defines the type of feature point to use for the edge (Corner or Tangent). A tangent edge point is the point selected based on the defined Edge Angle. A corner edge point is the intersect point between the fitted surface line and a edge line formed by interpolating the points at and after the tangent within the edge region.
Region	The region to which the tool's measurements will apply. For more information, see <i>Regions</i> on page 130.

Anchoring

Anchor	Description
X or Z	Lets you choose the X or Z measurement of another tool to use as a positional anchor for this tool.



A measurement *must* be enabled in the other tool for it to be available as an anchor. The anchor measurement should also be properly configured before using it as an anchor.



For more information on anchoring, see *Measurement Anchoring* on page 137.

Strip

The Strip tool measures the width of a strip.

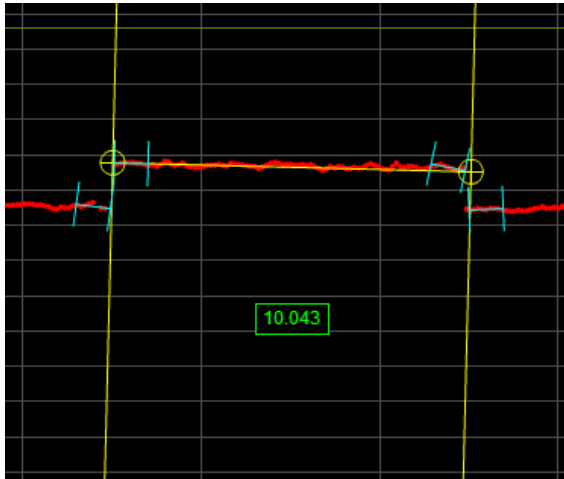

Parameters Anchoring

Source: Top

Base Type: Flat

Left Edge

Rising Data End

Falling Void

Right Edge

Tilt Enabled:

Support Width: 5 mm

Transition Width: 0 mm

Min Width: 0 mm

Min Height: 2 mm

Max Void Width: 0 mm

Region

X Add

X	<input type="checkbox"/>	<input checked="" type="checkbox"/>
Z	<input type="checkbox"/>	<input checked="" type="checkbox"/>
Width	<input checked="" type="checkbox"/>	10.043
Height	<input type="checkbox"/>	<input checked="" type="checkbox"/>

Id: 12

Parameters Output

Select Type: Index Left

Index: 0

The Strip tool uses a complex feature-locating algorithm to find a strip and then return measurements. See "Strip Algorithm" in the *Gocator Measurement Tool Technical Manual* for a detailed explanation of the algorithm. The behavior of the algorithm can be adjusted by changing the parameters in the measurement panel.

The Strip tool lets you add multiple measurements of the same type to receive measurements and set decisions for multiple strips. Multiple measurements are added by using the drop-down above the list of measurements and clicking on the **Add** button.

For example, if a target has three strips, by adding two measurements, choosing **Index From The Left** in the **Select Type** setting, and providing values of 1 and 3 in the **Index** of field of the measurements, respectively, the Strip tool will return measurements and decisions for the first and third strip.

For information on adding, managing, and removing tools and measurements, as well as detailed descriptions of settings common to most tools, see *Tools Panel* on page 129.

Measurements

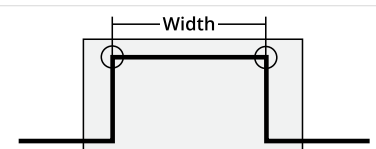
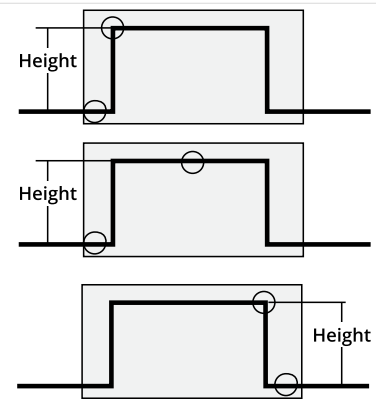
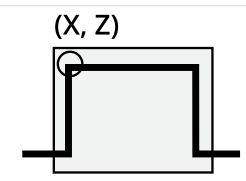
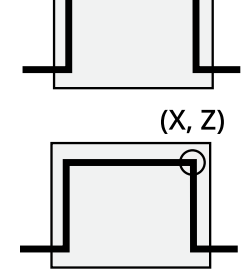
Measurement	Illustration
<p>Width</p> <p>Measures the width of a strip.</p>	
<p>Height</p> <p>Measures the height of a strip.</p>	
<p>X</p> <p>Measures the X position of a strip.</p>	
<p>Z</p> <p>Measures the Z position of a strip.</p>	

Parameters

Parameter	Description
Source	The sensor, or combination of sensors, that provides data for the tool's measurements. For more information, see <i>Source</i> on page 130.

Parameter	Description
Base Type	Affects detection of rising and falling edges.

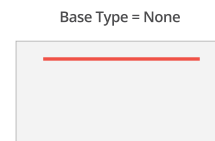
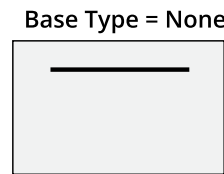
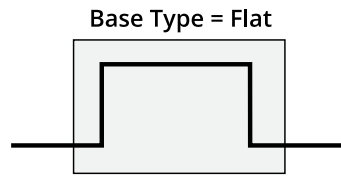

When **Base Type** is set to **Flat**, both strip (raised area) and base support regions are needed. When set to **None**, only a point that deviates from a smooth strip support region is needed to find a rising or falling edge.

Left Edge	Specifies the features that will be considered as the strip's left and right edges. You can select more than one condition.
Right Edge	
	<p>Rising - Rising edge detected based on the strip edge parameters.</p> <p>Falling - Falling edge detected based on the strip edge parameters.</p> <p>Data end - First valid profile data point in the measurement region.</p> <p>Void - Gap in the data that is larger than the maximum void threshold. Gaps connected to the measurement region's boundary are not considered as a void.</p> <p>See "Strip Start and Terminate Conditions" in the <i>Gocator Measurement Tool Technical Manual</i> for the definitions of these conditions.</p>

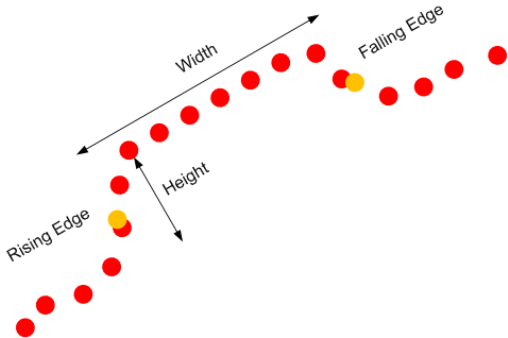
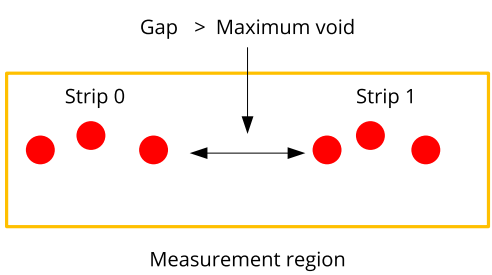
Parameter	Description
Tilt Enabled	<p>Enables/disables tilt correction.</p> <p>The strip may be tilted with respect to the sensor's coordinate X axis. This can be caused by conveyor vibration. If the Tilt option is enabled, the tool will report the width and height measurements following the tilt angle of the strip.</p> 
Support Width	Specifies the width of the region around the edges from which the data is used to calculate the step change. See "Strip Step Edge Definitions" in the <i>Gocator Measurement Tool Technical Manual</i> on how this parameter is used by different base types.
Transition Width	Specifies the nominal width needed to make the transition from the base to the strip. See "Strip Step Edge Definitions" in the <i>Gocator Measurement Tool Technical Manual</i> on how this parameter is used by different base types.
Min Width	Specifies the minimum width for a strip to be considered valid.
Min Height	Specifies the minimum deviation from the strip base. See "Strip Step Edge Definitions" in the <i>Gocator Measurement Tool Technical Manual</i> on how this parameter is used for different base types.
Max Void Width	<p>The maximum width of missing data allowed for the data to be considered as part of a strip when Void is selected in the Left or Right parameter. This value must be smaller than the edge Support Width.</p> 

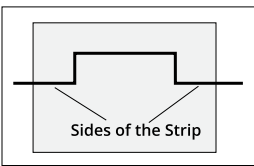
Parameter	Description
Region	<p>The measurement region defines the region in which to search for the strip. If possible, the region should be made large enough to cover the base on the left and right sides of the strip.</p>  <p>For more information, see <i>Regions</i> on page 130.</p>
Location <i>(Strip Height, Strip X, and Strip Z measurements only)</i>	<p>Specifies the strip position from which the measurements are performed.</p> <p>Left - Left edge of the strip. Right - Right edge of the strip. Center - Center of the strip.</p>
Select Type	<p>Specifies how a strip is selected when there are multiple strips within the measurement area.</p> <p>Best - The widest strip. Index Left - 0-based strip index, counting from left to right. Index Right - 0-based strip index, counting from right to left.</p>
Index	0-based strip index.
Filters	The filters that are applied to measurement values before they are output. For more information, see <i>Filters</i> on page 136.
Decision	The Max and Min settings define the range that determines whether the measurement tool sends a pass or fail decision to the output. For more information, see <i>Decisions</i> on page 134.

Anchoring

Anchor	Description
X or Z	Lets you choose the X or Z measurement of another tool to use as a positional anchor for this tool.

 A measurement *must* be enabled in the other tool for it to be available as an anchor. The anchor measurement should also be properly configured before using it as an anchor.

 For more information on anchoring, see *Measurement Anchoring* on page 137.

Template Matching



This tool is not supported on A and B revision Gocator 2100 and 2300 sensors. However, it is supported on any accelerated sensors (PC or GoMax), including these models, and will appear in emulator scenarios created using these sensors.

The Profile Template Matching tool lets you align a profile to a "master" template profile you create in the tool (a "golden template"), compensating for movement of the target from frame to frame. As a result, you can perform measurements over on a "stabilized" profile.

The tool returns measurements that represent differences between the profile and the master, letting you perform simple defect detection and location from within the tool.

The tool also outputs an aligned profile that other Profile measurement tools can use as input (via their **Stream** parameter). Finally, the tool produces a "difference" profile on which you can similarly perform measurements.

The sensor compares the measurement value with the values in **Min** and **Max** to yield a decision. For more information on decisions, see *Decisions* on page 134.

In the data viewer, the profiles are rendered using different colors:

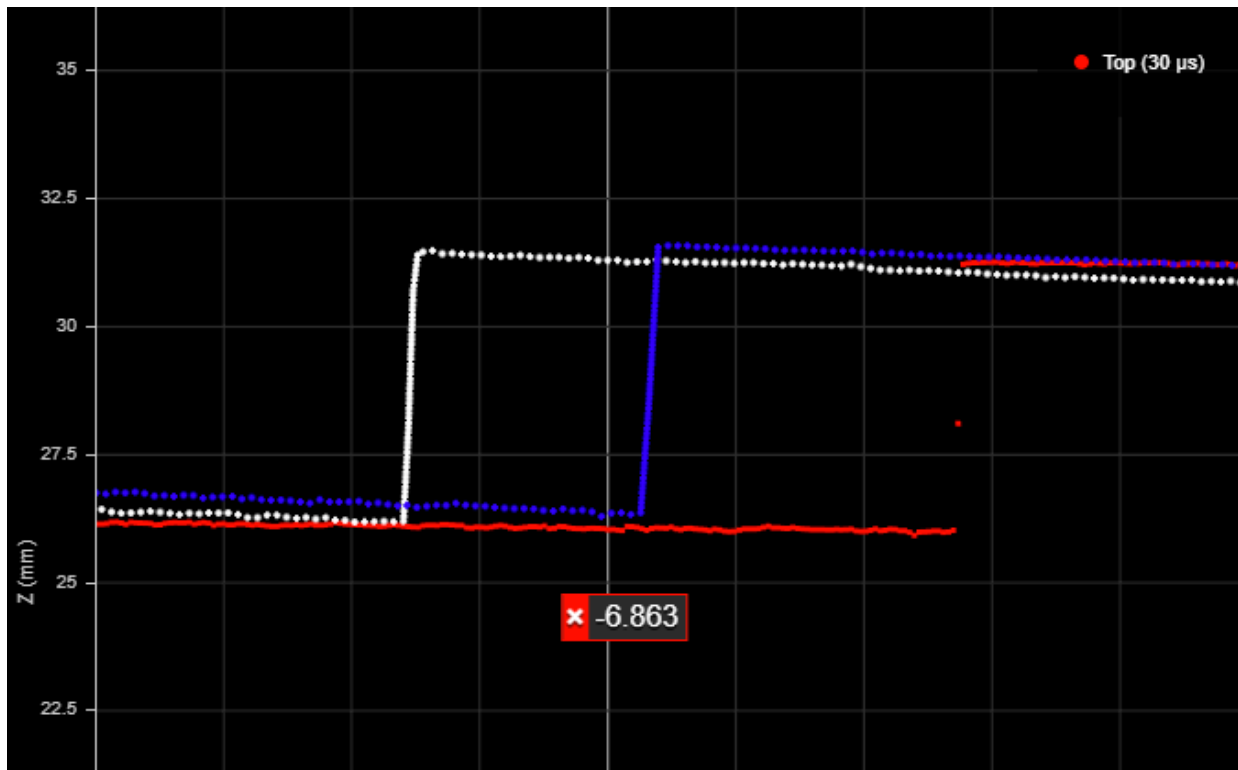

The master profile is rendered in white. The aligned profile is rendered in blue. The current profile is rendered in red.

Note that in the image above, the tool is performing only a rough alignment to ensure that the different profiles are clearly visible. Typically, the blue aligned profile will be on top of the white master profile.

For information on adding, managing, and removing tools and measurements, as well as detailed descriptions of settings common to most tools, see *Tools Panel* on page 129.

Measurements, Features, and Settings

Note that if no profile alignment is performed (both **Coarse Align** and **Fine Align** are disabled), for example, if the targets are sufficiently fixed from profile to profile, the following measurements return 0.000:

- Transform X
- Transform Z
- Transform Y Angle

Master Compare must be enabled for the following measurements; otherwise, they return Invalid values:

- Max Height Difference
- Max Difference Position X
- Max Difference Position Z
- Standard Deviation
- Difference Average
- Difference Sum
- Variance
- Matching Score

Also, for these “master compare” measurements, if the profile has been aligned to the master (either **Coarse Align** or **Fine Align** is enabled), the measurement compares the *aligned* profile and the master. If the profile has not been aligned (both alignment parameters are disabled), the measurement compares the *original* (unaligned) profile and the master.

Measurements

Measurement

Transform X

Transform Z

The distance the profile has shifted on the X and Z axis after alignment to the master, respectively.

Transform Y Angle

The rotation of the profile around the Y axis after alignment.

Max Height Difference

The maximum height difference between the profile and the master.

Max Difference Position X

Max Difference Position Z

The X and Z positions of the maximum height difference between the profile and the master.

Standard Deviation

The standard deviation between the profile and the master.

Measurement

Difference Average

The average difference on the Z axis between the profile and the master.

Difference Sum

The sum of the differences on the Z axis between the profile and the master.

Variance

Returns the variance of a difference profile calculated by subtracting the current profile from the master.

Matching Score

Returns a value between 0 and 1 that is the is the percentile of standard deviation of a difference profile (calculated by subtracting the current profile from the master) from the tolerance.

Data

Type	Description
Aligned Profile	The profile aligned to the master.
Difference Profile	A profile representing the differences between the profile and the master. Z values in the difference profile above 0 represent data points higher in the profile than in the master. Z values in the difference profile below 0 represent data points lower in the profile than in the master. Z values in the difference profile at 0 represent data points that are the same in the profile and the master.

Parameters

Parameter	Description
Source	The sensor, or combination of sensors, that provides data for the tool's measurements. For more information, see <i>Source</i> on page 130.
File	A list of templates available to the tool. The template containing the profile the tool uses as a master profile for alignment and comparisons. Use the Operation parameter to add and remove templates to this list.
Operation	Provides operations related to profile template files (masters). One of the following: Save – Saves the current profile to a template file in the local file system and adds it to the list in File . Multiple templates can be available. Files are persistent. Delete – Deletes the template file selected in File . (This parameter switches to “Normal” after the tool performs one of the file operations.)
Use Region	Indicates whether the tool uses a user-defined region to perform <i>matching</i> . (The tool uses <i>only</i> the data profile and master data in this region to perform matching.) If this option is not checked, the tool performs matching using data from the entire active area.

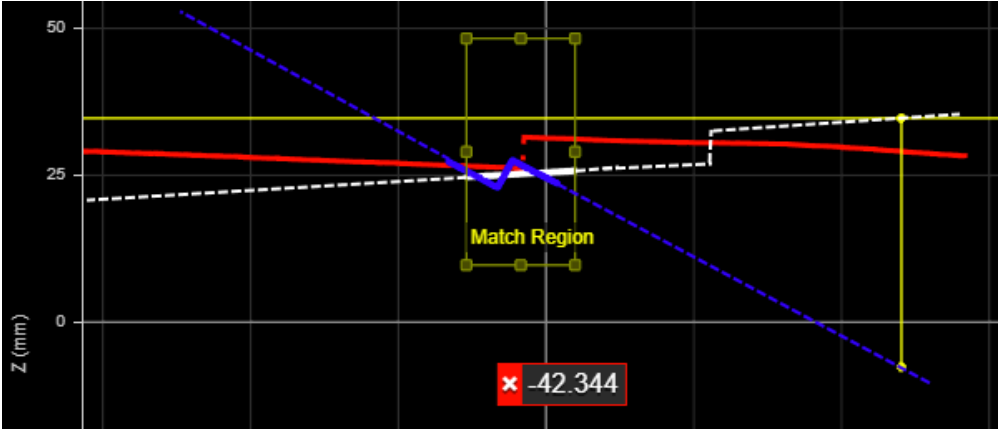
Parameter	Description
Match Region	<p>Size and position of the region in which the matching (alignment) is performed..</p> <p>Master comparison measurements however are applied to the entire profile (current profile and master). For example, in the following image, the tool limits matching to the data in the match region. But the measurement (Max Height Difference in this case) is calculated on the data outside the region.</p> 
	(The dashed lines are added to illustrate the hidden aligned profile and master.)
Coarse Align	When enabled, shows the X Shift Window parameter. Use this setting by itself if you expect targets will only move along the X and Z axes (that is, you don't expect rotation). Otherwise, when combined with Fine Align , it provides a good initial start position for fine alignment.
X Shift Window	The maximum distance on the X axis the tool can move the current profile in order to align it. Should be set to the maximum amount the part is expected to shift left or right. (Enabled using the Coarse Align parameter.)
Fine Align	When enabled, lets you set the Max Iteration and Match Window parameters for fine alignment. This alignment method is more accurate than coarse alignment but takes more time to run.
Max Iteration	The maximum number of iterations the tool uses to perform fine alignment of the profile to the master.
Match Window	The region in which points are evaluated for a match. If there's a larger difference between the current profile and the master than the match window size, it would ignore the point.
Master Compare	<p>Causes the tool to compare the current profile to the master profile and return results in some of the tool's measurements. (See list above.)</p> <p>When disabled, the measurements that compare the profile to the master return invalid values.</p>
Difference Profile Median Size	Defines the size of the window the tool uses to smooth out noise in the Difference Profile data output.
Tolerance	The difference tolerance for the master comparison.
Display Master	Displays the Master template (white profile).
Display Aligned Profile	Displays the aligned (blue profile).

Parameter	Description
Filters	The filters that are applied to measurement values before they are output. For more information, see <i>Filters</i> on page 136.
Decision	The Max and Min settings define the range that determines whether the measurement tool sends a pass or fail decision to the output. For more information, see <i>Decisions</i> on page 134.

Anchoring

Anchor	Description
X or Z	Lets you choose the X or Z measurement of another tool to use as a positional anchor for this tool.

 A measurement *must* be enabled in the other tool for it to be available as an anchor. The anchor measurement should also be properly configured before using it as an anchor.

 For more information on anchoring, see *Measurement Anchoring* on page 137.

Script

A Script measurement can be used to program a custom measurement using a simplified C-based syntax. A script measurement can produce multiple measurement values and decisions for the output.

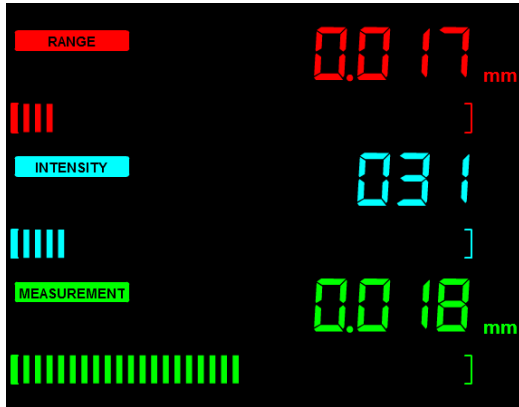

```
Code
1 double PositionZ = Measurement_Value(0);
2
3 if (Measurement_Valid(0))
4 {
5   Output_Set(PositionZ + 10000, 1);
6 }
7 else
8 {
9   Output_Set(0, 0);
10 }
11
```

*Press save button or 'Ctrl+S' to apply change.
Press 'Esc' to exit full screen.

Output:

Output 0

Id:

See *Scripts* on page 228 for more information on the script syntax.

To create or edit a Script measurement:

1. Add a new Script tool or select an existing Script measurement.

2. Edit the script code.

3. Add script outputs using the **Add** button.

For each script output that is added, an index will be added to the **Output** drop-down and a unique ID will be generated.

To remove a script output, click on the button next to it.

4. Click the **Save** button to save the script code.

If there is a mistake in the script syntax, the result will be shown as a "Invalid" with a red border in the data viewer when you run the sensor.

Outputs from multiple measurement tools can be used as inputs to the script. A typical script would take results from other measurement tools using the value and decision function, and output the result using the output function. Stamp information, such as time and encoder stamps, are available in the script, whereas the actual profile3D point cloud data is not. (The script engine is not powerful enough to process the data itself.) Only one script can be created.

Feature Measurement

The following sections describe Gocator's Feature tools.

Feature tools produce measurements based on more complex geometry, letting you implement applications more quickly by reducing dependence on writing scripts to accomplish these kinds of measurements. Feature tools take [geometric features](#) generated by other tools as input and perform measurements on those features.

Feature tools are available in Profile mode.

Create

The Feature Create tool lets you generate geometric features from other geometric features (ones generated by other tools). For example, you can create a line from two points, or create a plane from a point and a line. The tool can generate points, lines, circles, or planes. You can also extract measurement values from the geometric features generated by other tools; you can use these values as decisions or use them as anchors in other tools. The advantage of the Feature Create tool is that it means you need to rely less on Script tools or SDK/GDK applications to perform complex geometric operations.

For example, in the following, a Feature Create tool takes the hole geometric features output by two Surface Hole tools to generate a line geometric feature (near-vertical yellow line between the cyan hole center points).

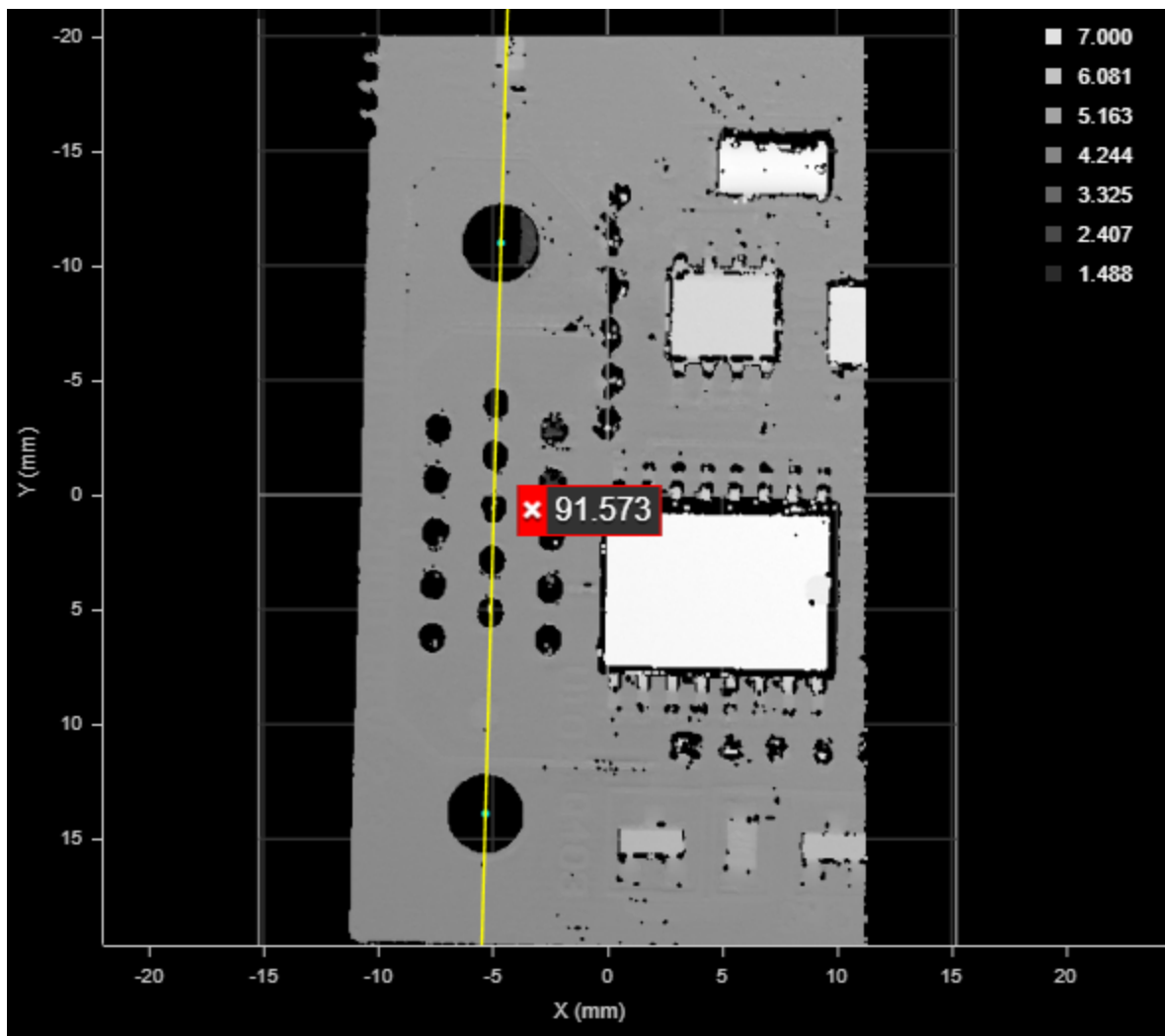

You could perform measurements on the resulting line (X, Y, and Z positional measurements on the line's center point, and, more importantly, angle measurements on the line). You could also use the line's Z angle as an anchor in other tool's in order to increase repeatability.

Parameters
Anchoring

Output: Line from two points

Point 1: Surface Hole - top/Center P...

Point 2: Surface Hole - bottom/Cent...

Show Detail

Measurements
Features

X	-4.981	☑
Y	1.459	☑
Z	4.134	☑
X Angle	-0.494	☑
Y Angle	-162.563	☑
Z Angle	91.573	☑

ID:

Output

Filters ☰

Decision

Min: mm

Max: mm

Measurement Panel

The following sections describe the output types available in the **Output** drop-down, the inputs required by each output, and the resulting output.

Line from Two Points

The **Line from two points** type of output takes two point geometric features as input.

The resulting output is a line geometric feature connecting the two points.

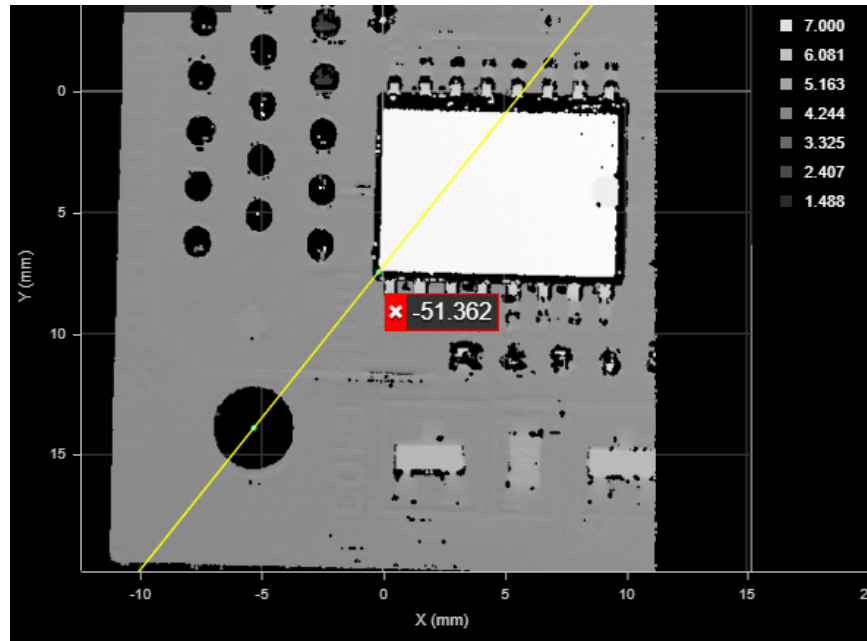

*A line between the center point of a hole and the corner of the chip.
 (The corner is the intersect point resulting from the Feature Intersect tool,
 taking the left vertical and lower horizontal line edges of the chip as input.)*

The X, Y, and Z measurements return the midpoint of the line. The X, Y, and Z Angle measurements return the angle of the line.

Perpendicular or Parallel Line from Point and Line

These types of output take a point and a line geometric feature as input to create another line.

For both of these types of line output, the X, Y, and Z measurements return the position of the point.

For perpendicular line output, the X, Y, and Z angle measurements return the angles of the line.

For parallel line output, the Z angle measurement returns the angle of the line; the X and Y angle measurements both return 180.000.

In the following, the tool generates a roughly vertical line (yellow) perpendicular to the input line (cyan line along the left edge of the large integrated circuit), passing through the input point (cyan dot at the center of the hole).

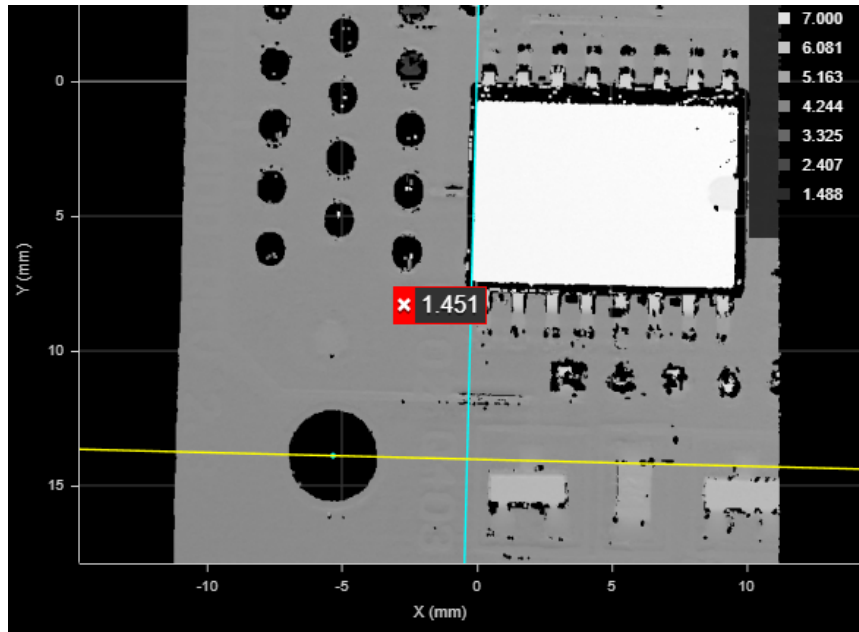

In the following, the tool generates a roughly horizontal line (yellow) parallel to the input line (cyan line along the bottom edge of the large integrated circuit), passing through the input point (cyan dot at the center of the hole).

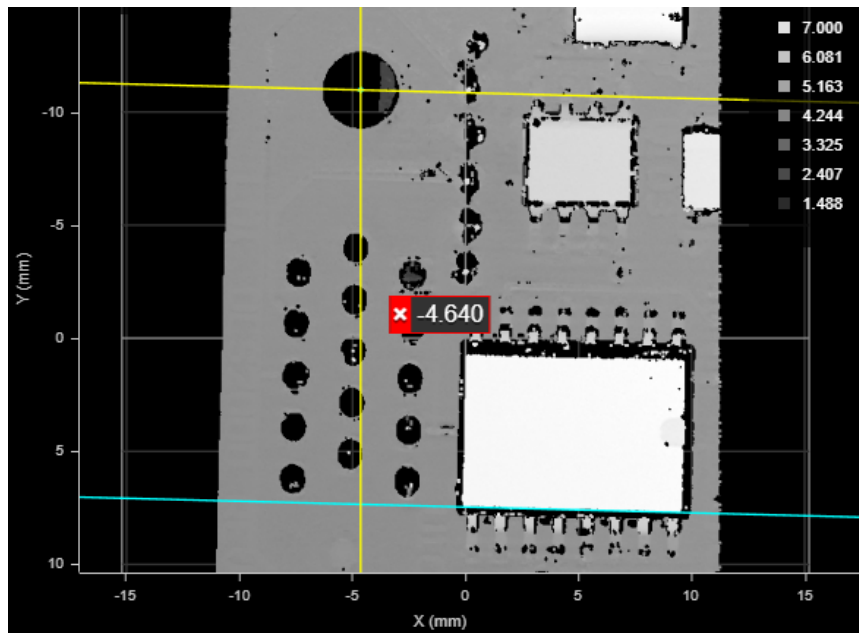

Perpendicular Line from Point to Plane

Creates a perpendicular line from a point up to a plane.

Projected Point on Plane

Creates a point projected onto a plane.

Projected Line on Plane

Creates a line projected onto a plane.

Circle from Points

The **Circle from points** output type takes three point geometric features and fits a circle to those points. The circle is always on the XY plane.

The X, Y, and Z measurements return the center of the circle. The X, Y, and Z Angle measurements return a 0.000 value.

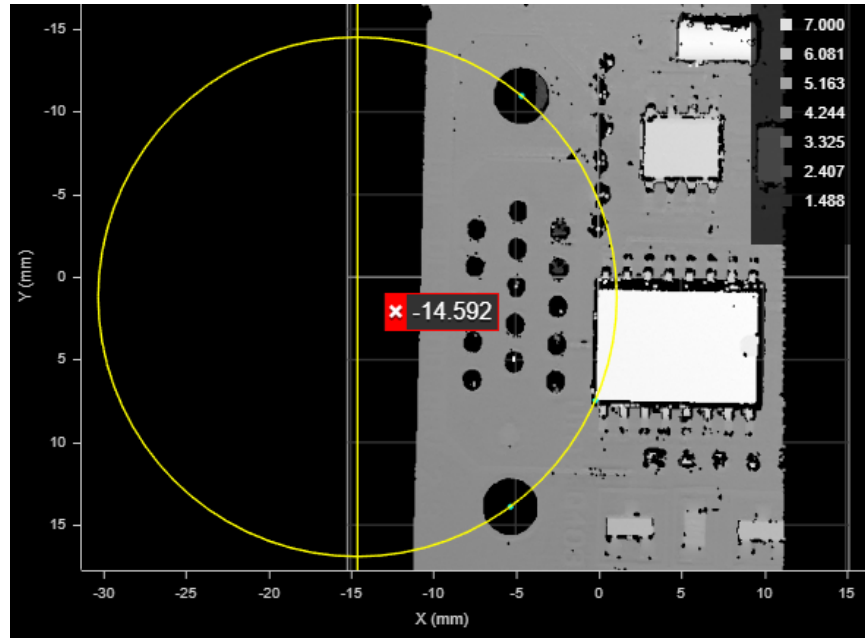

*Circle generated from the center points of the two holes and the corner of the chip (cyan points).
(The corner is the intersect point resulting from the Feature Intersect tool,
taking the left vertical and lower horizontal line edges of the chip as input.)*

Plane from Point and Normal

Creates a plane from a point and a normal.

Plane from Three Points

Creates a plane from three points.

Line from Two Planes

The **Line from two planes** output type takes two plane geometric features as input and creates a line at their intersection.

The X, Y, and Z measurements return the midpoint. The X, Y, and Z Angle measurements return the angle of the line.

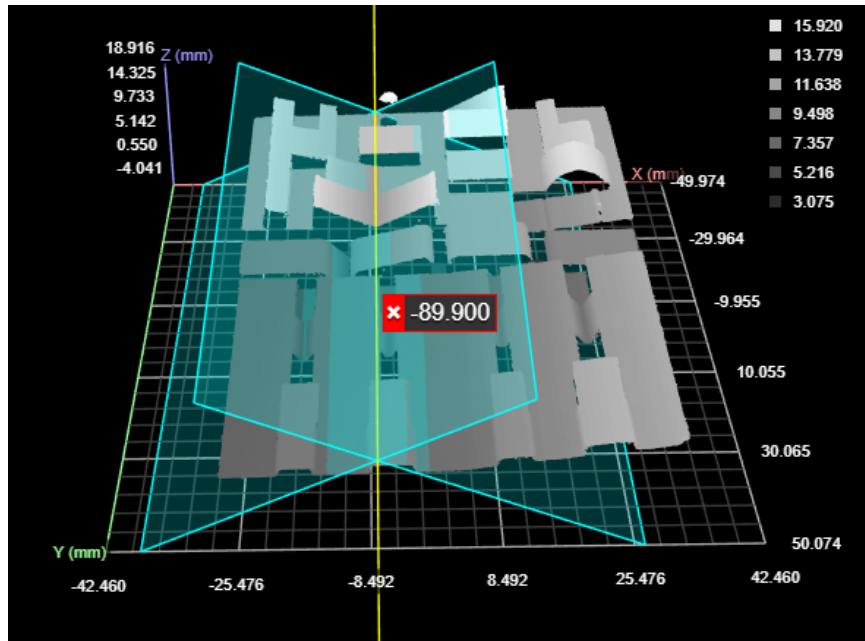

A line generated at the intersection of two planes. The Z angle is indicated.

Point from Three Planes

The **Point from three planes** output type takes three plane geometric features as input and creates a point at their intersection.

The X, Y, and Z measurements return the position of the intersect point. The X, Y, and Z Angle measurements return 0.000 values.

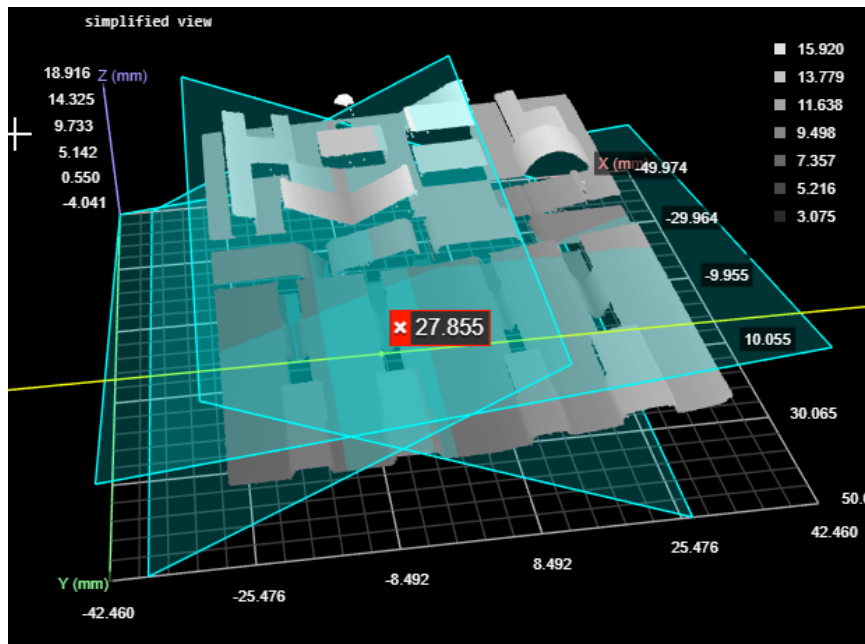

A point generated at the intersection of two planes. The Y position is indicated here.

Point from Line and Circle

Creates a point from a line and a circle (their intersection).

Point or Line

The **Point** and **Line** types of output take a point or a line geometric feature as input, respectively.

These outputs are useful if the tool takes features generated by another Feature Create tool as input, on which you want to perform measurements in the second Feature Create tool. Also, this can be useful if you have developed GDK tools that only generate geometric features (no measurements): you can use this tool to extract those measurements.

For point output, the X, Y, and Z measurements return the X, Y, and Z position of the point; the angle measurements all produce 0.000 as values.

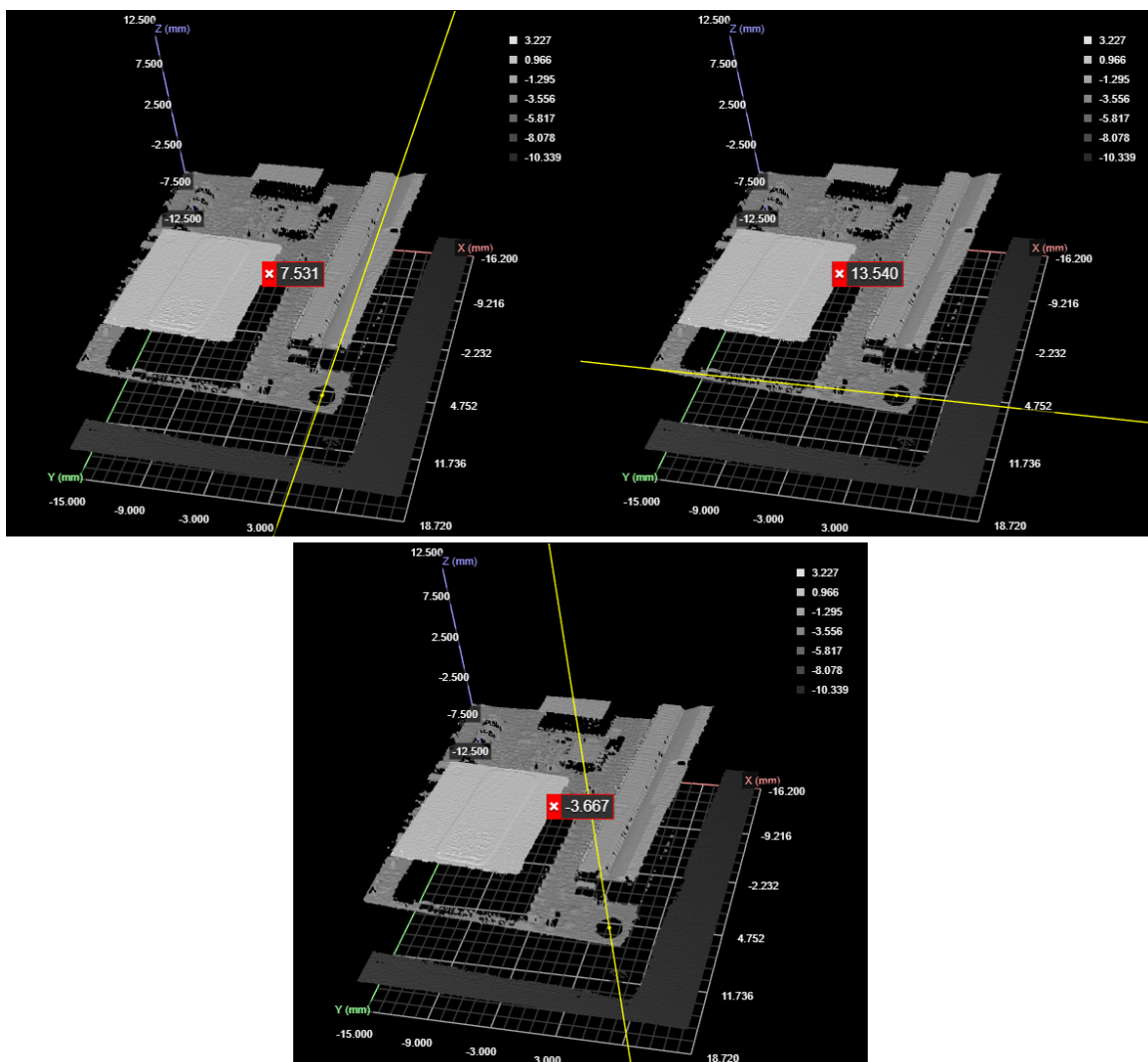

Positional measurements of a point

For line output, the X, Y, and Z measurements return the midpoint of the line. The Z Angle measurement returns the angle of the line around the Z axis. The X angle is always 0.000, and the Y angle is always 180.000.

See *Adding and Configuring a Measurement Tool* on page 129 for instructions on how to add measurement tools.

Measurements

Measurement

X, Y, Z

The X, Y, and Z positions of some aspect of the geometric feature. For more information, see the sections above.

X Angle, Y Angle, Z Angle

The X, Y, and Z angles of some aspect of the geometric feature. For more information, see the sections above.

Note that even when enabled on the **Features** tab, not all features are generated. (For example, with Line selected as the output type, only a line geometric feature can be generated: point, circle, and plane features are not generated.)

Features

Type	Description
Point	The generated point geometric feature.
Line	The generated line geometric feature.
Circle	The generated circle geometric feature.
Plane	The generated plane geometric feature.

Parameters

Parameter	Description
Output	The type of output the tool generates. Switching between the options changes the input types displayed in the tool.
Show Detail	Toggles the display of the input geometric features in the data viewer.
Filters	The filters that are applied to measurement values before they are output. For more information, see <i>Filters</i> on page 136.
Decision	The Max and Min settings define the range that determines whether the measurement tool sends a pass or fail decision to the output. For more information, see <i>Decisions</i> on page 134.

Dimension

The Feature Dimension tool provides dimensional measurements from a point [geometric feature](#) to a reference point or line geometric feature.

The sensor compares the measurement value with the values in **Min** and **Max** to yield a decision. For more information on decisions, see *Decisions* on page 134.

See *Adding and Configuring a Measurement Tool* on page 129 for instructions on how to add measurement tools.

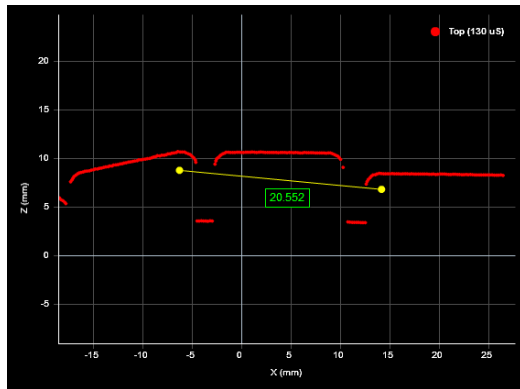

Parameters

Point: Profile Circle - Left/Center P... ▾

Reference Feature: Profile Circle - Right/Center... ▾

Width

Length

Height

Distance **20.552**

Plane Distance

ID:

Parameters Output

Filters

Decision

Min: mm

Max: mm

Measurement Panel

 In the following measurement descriptions, the first geometric feature is set in the **Point** drop-down. The second geometric feature is set in the **Reference Feature** drop-down.

Measurements

Measurement

Width

Point-point: The difference on the X axis between the points.

Point-line: The difference on the X axis between the point and a point on the line. For profiles, the point on the line is at the same Z position as the first point.

Length

Point-point: The difference on the Y axis between the points.

Point-line: The difference on the Y axis between the point and, for profiles, the nearest point on the line; currently, always zero.

Measurement

Height

Point-point: The difference on the Z axis between the points.

Point-line: The difference on the Z axis between the point and, for profiles, a point on the line at the same X position as the first point.

Distance

Point-point: The direct, Euclidean distance between two point geometric features.

Point-line: The direct, Euclidean distance between a point and the nearest point on the line.

Plane Distance

Point-point: The distance between two point geometric features. For profile data, the points are projected onto the XZ plane (always the same as the Distance measurement).

Point-line: The distance between a point and a line. For profile data, projected onto the XZ plane (always the same as the Distance measurement).

Parameters

Parameter	Description
Point	A point geometric feature generated by another tool.
Reference Feature	A point or line geometric feature generated by another tool. Dimensional measurements are calculated <i>from</i> the reference feature <i>to</i> the point in the Point setting.
Filters	The filters that are applied to measurement values before they are output. For more information, see <i>Filters</i> on page 136.
Decision	The Max and Min settings define the range that determines whether the measurement tool sends a pass or fail decision to the output. For more information, see <i>Decisions</i> on page 134.

Intersect

The Feature Intersect tool returns the intersection of a line [geometric features](#) and a reference line or plane geometric feature. For line-line intersections, the lines are projected onto the $Y = 0$ plane for features extracted from a profile. The angle measurement between the two lines is also returned

The Feature Intersect tool saves you from having to write complicated calculations in [script tools](#) to find intersect point between lines. Previously, calculating the intercept point of two lines was difficult and prone to bugs, involving finding lines in indirect ways.

The Feature Intersect tool can also generate a point [geometric feature](#) representing the point of intersection of the lines that the [Feature Dimension](#) tool can use in measurements.

The sensor compares the measurement value with the values in **Min** and **Max** to yield a decision. For more information on decisions, see *Decisions* on page 134.

See *Adding and Configuring a Measurement Tool* on page 129 for instructions on how to add measurement tools.

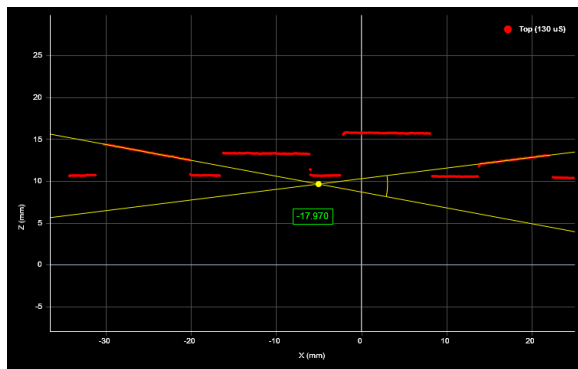

Measurement Panel

Measurements

Measurement

X

Line-Line: The X position of the intersect point between the lines.

Line-Plane: The X position of the intersect point between the line and the plane.

Measurement

Y

Line-Line: The Y position of the intersect point between the lines.

Line-Plane: The Y position of the intersect point between the line and the plane.

Z

Line-Line: The Z position of the intersect point between the lines.

Line-Plane: The Z position of the intersect point between the line and the plane.

Angle

Line-Line: The angle between the lines, as measured from the line selected in **Reference Feature** to the line selected in **Line**. Line-line angles can range over 360 degrees, expressed either as an angle from -180 to 180 or as an angle from 0 to 360 degrees.

Line-Plane: The angle between the line and the perpendicular projection of the line onto the plane, as measured from the plane geometric feature selected in **Reference Feature** to the line selected in **Line**. Line-plane angles are expressed as an angle from 90 to -90 degrees, which can be expressed as an absolute value.

In both cases, use the **Angle Range** setting to determine how angles are expressed.

Features

Type	Description
------	-------------

Intersect Point	The intersect point of the two edge lines.
-----------------	--

Parameters

Parameter	Description
-----------	-------------

Line	A line geometric feature generated by another tool.
------	---

Reference Feature	A line or plane geometric feature generated by another tool. For the Angle measurement, the angle is measured <i>from</i> the reference feature.
-------------------	--

Angle Range	Determines the angle range.
-------------	-----------------------------

(Angle measurement only)

Filters	The filters that are applied to measurement values before they are output. For more information, see <i>Filters</i> on page 136.
---------	--

Decision	The Max and Min settings define the range that determines whether the measurement tool sends a pass or fail decision to the output. For more information, see <i>Decisions</i> on page 134.
----------	---

Robot Pose

Gocator single point profilers do not support the Feature Robot Pose tool.

Scripts

Scripts use outputs from other measurement tools to produce custom measurements.

Similar to other measurement tools, a script measurement can output multiple measurement values and decisions. Scripts are added, configured, and removed much like other measurement tools; for more information on this, see *Script* under *Profile Measurement* on page 149.

 Scripts must be less than 27,000 characters long.

Scripts use a simplified C-based syntax. The following elements of the C language are supported:

Supported Elements

Elements	Supported
Control Operators	if, while, do, for, switch and return.
Data Types	char, int, unsigned int, float, double, long long (64-bit integer).
Arithmetic and Logical Operator	Standard C arithmetic operators, except ternary operator (i.e., "condition? trueValue: falseValue"). Explicit casting (e.g., int a = (int) a_float) is not supported.
Function Declarations	Standard C function declarations with argument passed by values. Pointers are not supported.

Built-in Script Functions

The script engine provides the following types of functions:

- Measurement
- Output
- Memory
- Runtime variable
- Stamp
- Math

Measurement Functions

Function	Description
int Measurement_Exists(int id)	Determines if a measurement exists by ID. Parameters: id – Measurement ID Returns: 0 – measurement does not exist 1 – measurement exists
int Measurement_Valid(int id)	Determines if a measurement value is valid by its ID. Parameters:

Function	Description
	id - Measurement ID Returns 0 - Measurement is invalid 1 - Measurement is valid
double Measurement_Value (int id)	Gets the value of a measurement by its ID. Parameters: id - Measurement ID Returns: Value of the measurement 0 - if measurement does not exist 1 - if measurement exists
int Measurement_Decision (int id)	Gets the decision of a measurement by its ID. Parameters: ID - Measurement ID Returns: Decision of the measurement 0 - if measurement decision is false 1 - If measurement decision is true
int Measurement_NameExists(char* toolName, char* measurementName)	Determines if a measurement exist by name. Parameter: toolName - Tool name measurementName - Measurement name Returns: 0 - measurement does not exist 1 - measurement exists
int Measurement_Id (char* toolName, char* measurementName)	Gets the measurement ID by the measurement name. Parameters: toolName - Tool name measurementName - Measurement name Returns: -1 - measurement does not exist Other value - Measurement ID

Output Functions

Function	Description
void Output_Set (double value, int decision)	Sets the output value and decision on Output index 0. Only the last output value / decision in a script run is kept and passed to the Gocator output. To output an invalid value, the constant INVALID_VALUE can be

Function	Description
	used (e.g., Output_SetAt(0, INVALID_VALUE, 0)) Parameters: value - value output by the script decision - decision value output by the script. Can only be 0 or 1
void Output_SetAt(unsigned int index, double value, int decision)	Sets the output value and decision at the specified output index. To output an invalid value, the constant INVALID_VALUE can be used (e.g., Output_SetAt(0, INVALID_VALUE, 0)) Parameters: index - Script output index value - value output by the script decision - decision value output by the script. Can only be 0 or 1
void Output_SetId(int id, double value, int decision)	Sets the output value and decision at the specified script output ID. To output an invalid value, the constant INVALID_VALUE can be used (e.g., Output_SetId(0, INVALID_VALUE, 0)) Parameters: id - Script output ID

Memory Functions

Function	Description
void Memory_Set64s (int id, long long value)	Stores a 64-bit signed integer in persistent memory. Parameters: id - ID of the value value - Value to store
long long Memory_Get64s (int id)	Loads a 64-bit signed integer from persistent memory. Parameters: id - ID of the value Returns: value - Value stored in persistent memory
void Memory_Set64u (int id, unsigned long long value)	Stores a 64-bit unsigned integer in the persistent memory Parameters: id - ID of the value value - Value to store
unsigned long long Memory_Get64u (int id)	Loads a 64-bit unsigned integer from persistent memory. Parameters: id - ID of the value Returns: value - Value stored in persistent memory
void Memory_Set64f (int id, double value)	Stores a 64-bit double into persistent memory.

Function	Description
	Parameters: id - ID of the value value - Value to store
double Memory_Get64f (int id)	Loads a 64-bit double from persistent memory. All persistent memory values are set to 0 when the sensor starts. Parameters: id - ID of the value Returns: value - Value stored in persistent memory
int Memory_Exists (int id)	Tests for the existence of a value by ID. Parameters: id - Value ID Returns: 0 - value does not exist 1 - value exists
void Memory_Clear (int id)	Erases a value associated with an ID. Parameters: id - Value ID
void Memory_ClearAll()	Erases all values from persistent memory

Runtime Variable Functions

Function	Description
int RuntimeVariable_Count()	Returns the number of runtime variables that can be accessed. Returns: The count of runtime variables.
int RuntimeVariable_Get32s(int id)	Returns the value of the runtime variable at the given index. Parameters: Id - ID of the runtime variable Returns: Runtime variable value

Stamp Functions

Function	Description
long long Stamp_Frame()	Gets the frame number of the last frame.
long long Stamp_Time()	Gets the time stamp of the last frame.
long long Stamp_Encoder()	Gets the encoder position of the last frame when the image data was scanned/taken.

Function	Description
long long Stamp_EncoderZ()	Gets the encoder position at the time of the last index pulse of the last frame.
unsigned int Stamp_Inputs()	Gets the digital input state of the last frame. Returns a bit field representing digital input states.

Math Functions

Function	Description
float sqrt(float x)	Calculates square root of x
float sin(float x)	Calculates sin(x) (x in radians)
float cos(float x)	Calculates cos(x) (x in radians)
float tan(float x)	Calculates tan(x) (x in radians)
float asin(float x)	Calculates asin(x) (x in radians)
float acos(float x)	Calculates acos(x) (x in radians)
float atan(float x)	Calculates atan(x) (x in radians)
float pow (float x, float y)	Calculates the exponential value. x is the base, y is the exponent
float fabs(float x)	Calculates the absolute value of x

Example: Accumulated Length

The following example shows how to create a custom measurement that is based on the values from other measurements and persistent values. The example calculates the length of the target using a series of position Z measurement tool values (Measurement ID 1)

```

/* Encoder Spacing is 0.5mm */
/* Z position measurement ID is set to 1 */

long long encoder_spacing = 500;
long long length = Memory_Get64s(0);

if (Measurement_Valid(1))
{
    length = length + encoder_spacing;
}
else
{
    length = 0;
}

Memory_Set64s(0, length);

```

```
if (length > 10000)
{
    Output_Set(length, 1);
}
else
{
    Output_Set(length, 0);
}
```

Output

The following sections describe the **Output** page.

Output Page Overview

Output configuration tasks are performed using the **Output** page. Gocator sensors can transmit data and measurement results to various external devices using several output interface options.

Up to two outputs can have scheduling enabled with ASCII as the Serial output protocol. When Selcom is the current Serial output protocol, only one other output can have scheduling enabled.

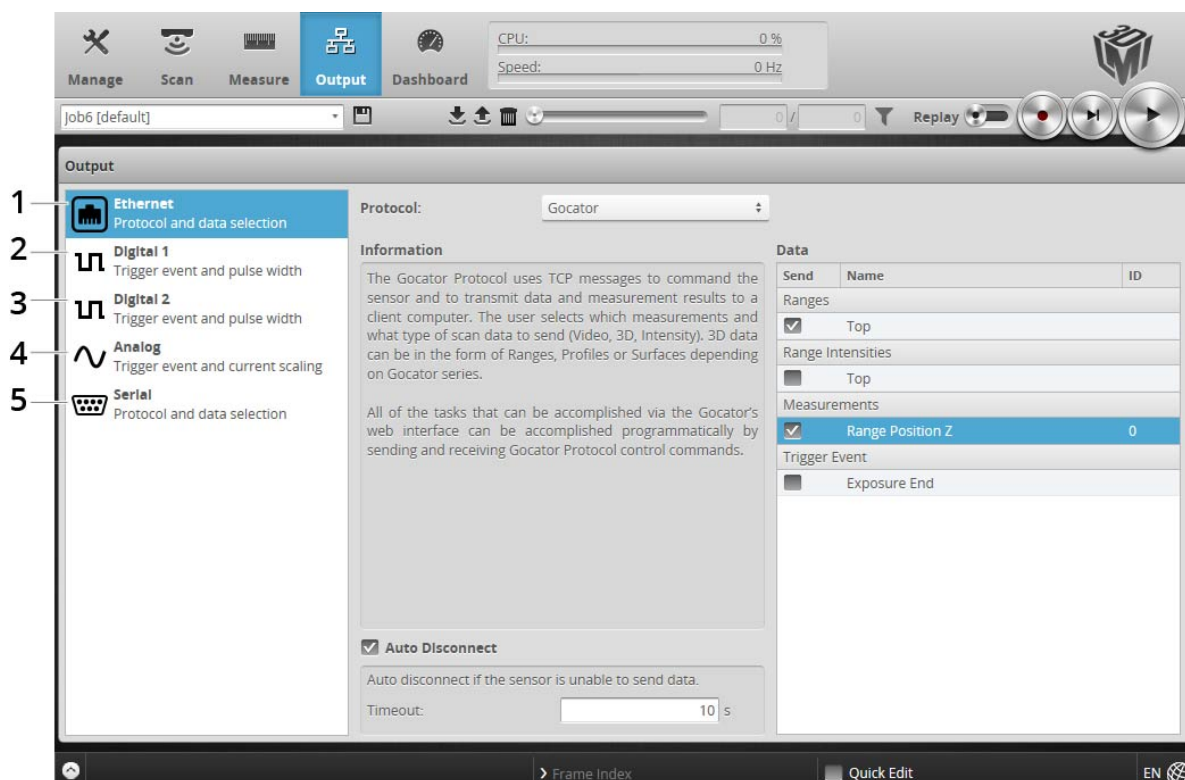

Category	Description
1 Ethernet	Used to select the data sources that will transmit data via Ethernet. See <i>Ethernet Output</i> on the next page.
2 Digital Output 1	Used to select the data sources that will be combined to produce a digital output pulse on Output 1. See <i>Digital Output</i> on page 239.
3 Digital Output 2	Used to select the data sources that will be combined to produce a digital output pulse on Output 2. See <i>Digital Output</i> on page 239.
4 Analog Panel	Used to convert a measurement value or decision into an analog output signal. See <i>Analog Output</i> on page 242.
5 Serial Panel	Used to select the measurements that will be transmitted via RS-485 serial output. See <i>Serial Output</i> on page 244.

Ethernet Output

A sensor uses TCP messages (Gocator protocol) to receive commands from client computers, and to send video, laser range, intensity, and measurement results to client computers. The sensor can also receive commands from and send measurement results to a PLC using ASCII, Modbus TCP, PROFINET, or EtherNet/IP protocol. See *Protocols* on page 342 for the specification of these protocols.

The specific protocols used with Ethernet output are selected and configured within the panel.

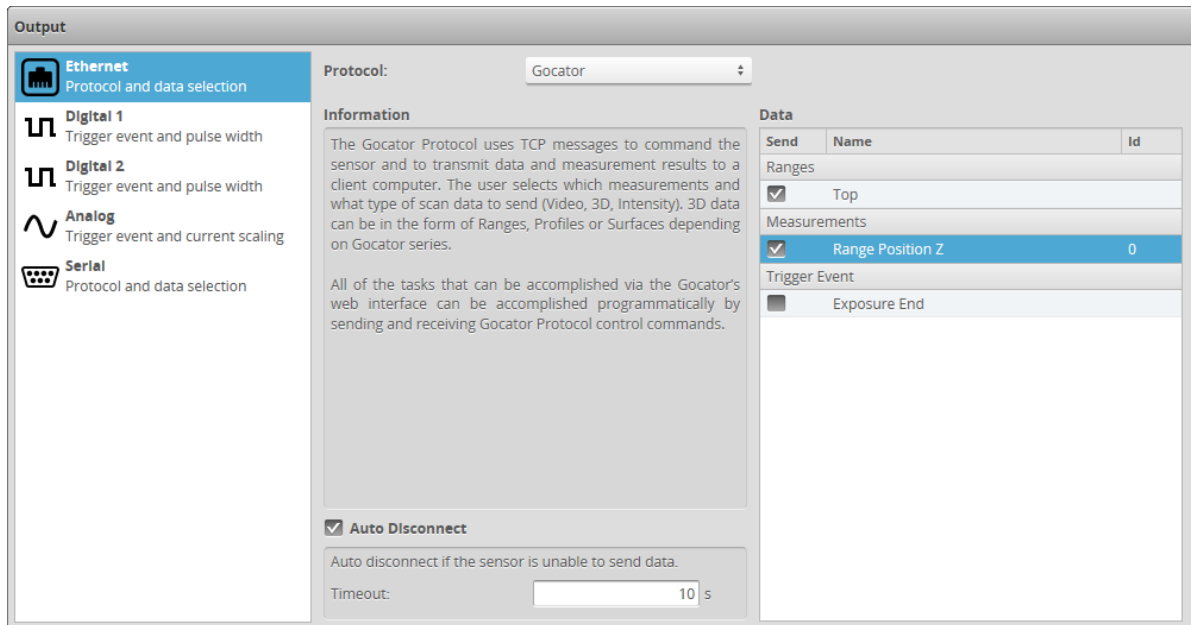

To receive commands and send results using Gocator Protocol messages:

1. Go to the **Output** page.
2. Click on the **Ethernet** category in the **Output** panel.
3. Select **Gocator** as the protocol in the **Protocol** drop-down.
4. Check the video, range, intensity, or measurement items to send.
5. (Optional) Uncheck the Auto Disconnect setting.
By default, this setting is checked, and the timeout is set to 10 seconds.

All of the tasks that can be accomplished with the Gocator's web interface (creating jobs, performing alignment, sending data and health information, and software triggering, etc.) can be accomplished programmatically by sending Gocator protocol control commands.

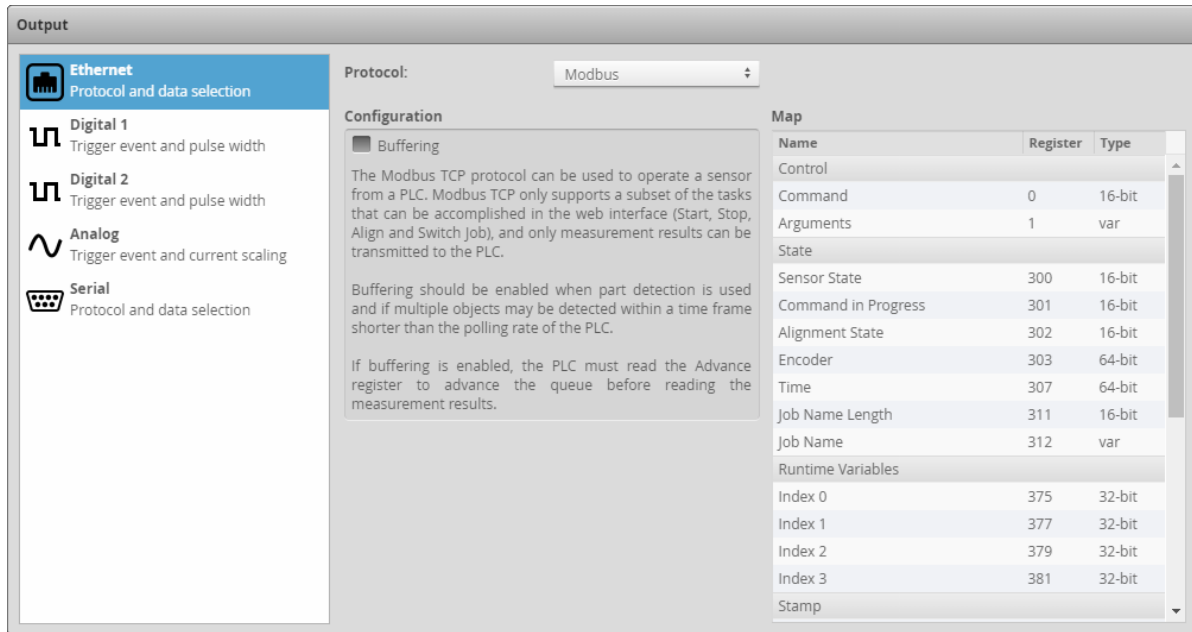

To receive commands and send results using Modbus TCP messages:

1. Go to the **Output** page.
2. Click on **Ethernet** in the **Output** panel.
3. Select **Modbus** as the protocol in the **Protocol** drop-down.
 Unlike the Gocator Protocol, you do not select which measurement items to output. The Ethernet panel will list the register addresses that are used for Modbus TCP communication.
 The Modbus TCP protocol can be used to operate a sensor. Modbus TCP only supports a subset of the tasks that can be performed in the web interface. A sensor can only process Modbus TCP commands when Modbus is selected in the **Protocol** drop-down.
4. Check the **Buffering** checkbox, if needed.
 Buffering is needed, for example, in Surface mode if multiple objects are detected within a time frame shorter than the polling rate of the PLC.
 If buffering is enabled with the Modbus protocol, the PLC must read the Advance register to advance the queue before reading the measurement results.

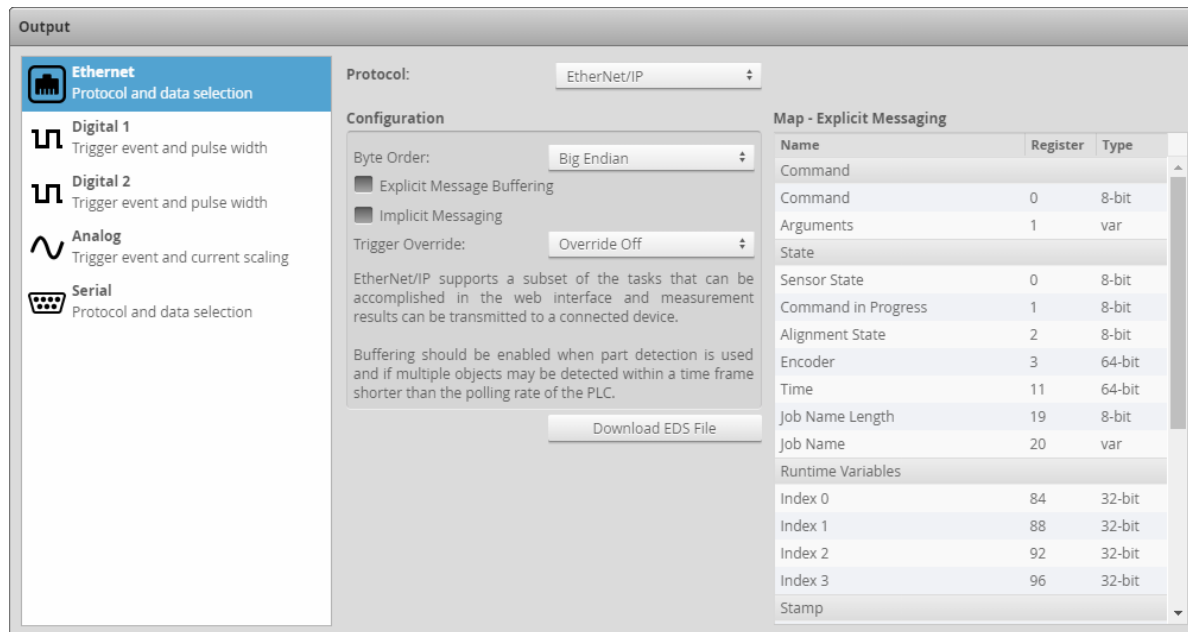

To receive commands and send results using EtherNet/IP messages:

1. Go to the **Output** page.
2. Click on **Ethernet** in the **Output** panel.
3. Select **EtherNet/IP** in the **Protocol** option.
 Unlike using the Gocator Protocol, you don't select which measurement items to output. The **Ethernet** panel will list the register addresses that are used for EtherNet/IP messages communication.
 The EtherNet/IP protocol can be used to operate a sensor. EtherNet/IP only supports a subset of the tasks that can be accomplished in the web interface. A sensor can only process EtherNet/IP commands when the EtherNet/IP is selected in the **Protocol** option.
4. Check the **Explicit Message Buffering** option, if needed.
 Buffering is needed, for example, in Surface mode if multiple objects are detected within a time frame shorter than the polling rate of the PLC. If buffering is enabled with the EtherNet/IP protocol, the buffer is automatically advanced when the Sample State Assembly Object is read (*Sample State Assembly* on page 414).
5. Check the **Implicit Messaging** option, if needed.
 Implicit messaging uses UDP and is faster than explicit messaging, so it is intended for time-critical applications. However, implicit messaging is layered on top of UDP. UDP is connectionless and data delivery is not guaranteed. For this reason, implicit messaging is only suitable for applications where occasional data loss is acceptable.
 For more information on setting up implicit messaging, see http://lmi3d.com/sites/default/files/APPNOTE_Implicit_Messaging_with_Allen-Bradley_PLCs.pdf.
6. Choose the byte order in the **Byte Order** dropdown.
7. Click the **Download EDS File** button to download an EDS file for use with your IDE.

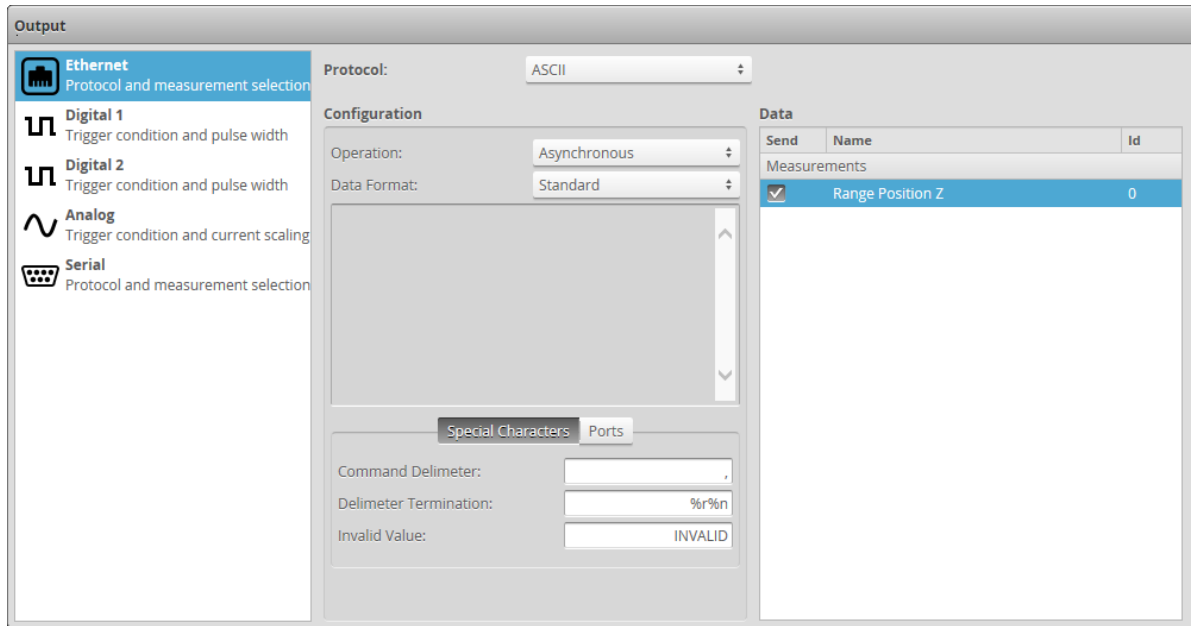

To receive commands and send results using ASCII messages:

1. Go to the **Output** page.
2. Click on **Ethernet** in the **Output** panel.
3. Select **ASCII** as the protocol in the **Protocol** drop-down.
4. Set the operation mode in the **Operation** drop-down.
In asynchronous mode, the data results are transmitted when they are available. In polling mode, users send commands on the data channel to request the latest result. See *Polling Operation Commands (Ethernet Only)* on page 468 for an explanation of the operation modes.
5. Select the data format from the **Data Format** drop-down.
Standard: The default result format of the ASCII protocol. Select the measurement to send by placing a check in the corresponding checkbox. See *Standard Result Format* on page 476 for an explanation of the standard result mode.
Standard with Stamp: Select the measurement to send by placing a check in the corresponding checkbox. See *Standard Result Format* on page 476 for an explanation of the standard result mode.
Custom: Enables the custom format editor. Use the replacement patterns listed in **Replacement Patterns** to create a custom format in the editor. C language *printf*-style formatting is also supported: for example, `%sprintf[%09d, %value[0]]`. This allows fixed length formatting for easier input parsing in PLC and robot controller logic.
6. Set the special characters in the **Special Characters** tab.
Set the command delimiter, delimiter termination, and invalid value characters. Special characters are used in commands and standard-format data results.
7. Set the TCP ports in the **Ports** tab.
Select the TCP ports for the control, data, and health channels. If the port numbers of two channels are the same, the messages for both channels are transmitted on the same port.

Digital Output

Gocator sensors can convert measurement decisions or software commands to digital output pulses, which can then be used to output to a PLC or to control external devices, such as indicator lights or air ejectors.



Digital outputs cannot be used when taking scans using the Snapshot button, which takes a single scan and is typically used to test measurement tool settings. Digital outputs can only be used when a sensor is running, taking a continuous series of scans.

A digital output can act as a measurement valid signal to allow external devices to synchronize to the timing at which measurement results are output. In this mode, the sensor outputs a digital pulse when a measurement result is ready.

A digital output can also act as a strobe signal to allow external devices to synchronize to the timing at which the sensor exposes. In this mode, the sensor outputs a digital pulse when the sensor exposes.

Each sensor supports two digital output channels. See *Digital Outputs* on page 542 for information on wiring digital outputs to external devices.

Trigger conditions and pulse width are then configured within the panel.

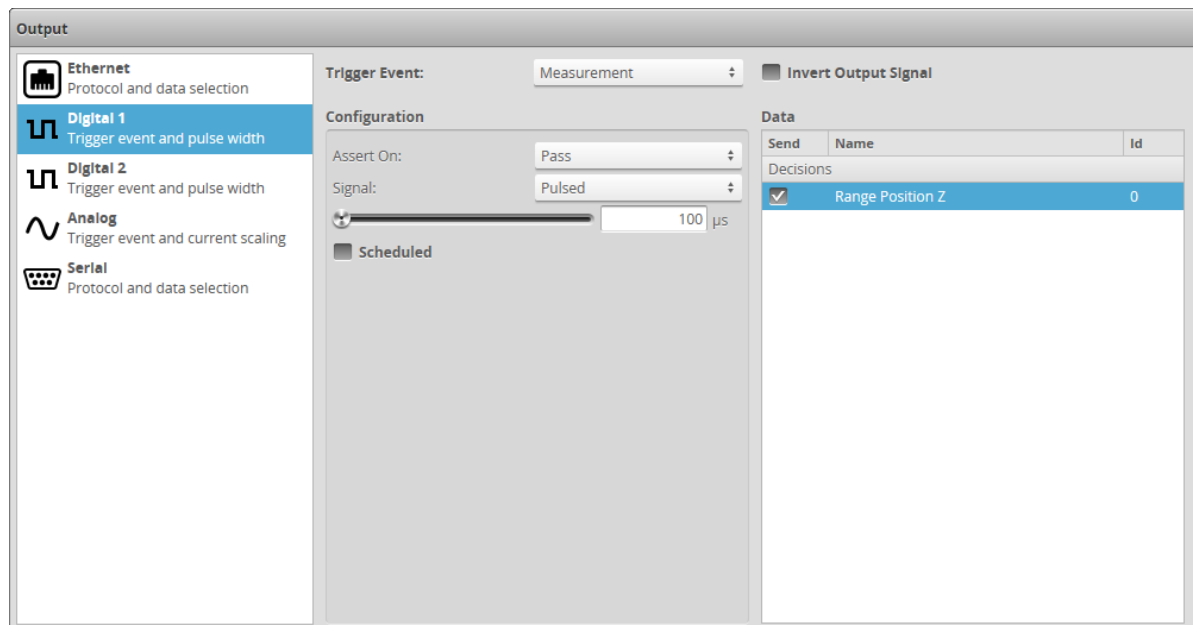

To output measurement decisions:

1. Go to the **Output** page.
2. Click **Digital 1** or **Digital 2** in the **Output** panel.
3. Set **Trigger Event** to **Measurement**.
4. In **Configuration**, set **Assert On** and select the measurements that should be combined to determine

the output.

If multiple measurement decisions are selected and **Assert On** is set to **Pass**, the output is activated when all selected measurements pass.

If **Assert On** is set to **Fail**, the output is activated when any one of the selected measurements fails.

5. Set the **Signal** option.
The signal type specifies whether the digital output is a continuous signal or a pulsed signal. If **Signal** is set to **Continuous**, the signal state is maintained until the next transition occurs. If **Signal** is set to **Pulsed**, you must specify the pulse width and how it is scheduled.
6. Specify a pulse width using the slider.
The pulse width is the duration of the digital output pulse, in microseconds.
7. Check the **Scheduled** option if the output needs to be scheduled; otherwise, leave it unchecked for immediate output.
A scheduled output becomes active after the delay from the start of Gocator exposure. A scheduled output can be used to track the decisions for multiple objects as these objects travel from the sensor to the eject gates.
The **Delay** setting specifies the distance from the sensor to the eject gates.
An immediate output becomes active as soon as measurement results are available. The output activates after the sensor finishes processing the data. As a result, the time between the start of sensor exposure and output activates can vary and is dependent on the processing latency. The latency is reported in the dashboard and in the health messages.
8. If you checked **Scheduled**, specify a delay and a delay domain.
The **Delay** specifies the time or encoder distance between the start of sensor exposure and when the output becomes active. The delay should be larger than the time needed to process the data inside the sensor. It should be set to a value that is larger than the processing latency reported in the dashboard or in the health messages.
The unit of the delay is configured with the **Delay Domain** setting.
9. If you want to invert the output signal, check **Invert Output Signal**.

To output a measurement valid signal:

1. Go to the **Output** page.
2. Click on **Digital 1** or **Digital 2** in the **Output** panel.
3. Set **Trigger Event** to **Measurement**.
4. In **Configuration**, set **Assert On** to **Always**.
5. Select the measurements.
The output activates when the selected decisions produce results. The output activates only once for each frame even if multiple decision sources are selected.
6. Specify a pulse width using the slider.
The pulse width determines the duration of the digital output pulse, in microseconds.

To respond to software scheduled commands:

1. Go to the **Output** page.
2. Click **Digital 1** or **Digital 2** in the **Output** panel.
3. Set **Trigger Event** to **Software**.
4. Specify a **Signal** type.
The signal type specifies whether the digital output is a continuous signal or a pulsed signal. If the signal is continuous, its state is maintained until the next transition occurs. If the signal is pulsed, user specifies the pulse width and the delay.
5. Specify a **Pulse Width**.
The pulse width determines the duration of the digital output pulse, in microseconds.
6. Specify if the output is immediate or scheduled.
A pulsed signal can become active immediately or be scheduled. A continuous signal always becomes active immediately.
Immediate output becomes active as soon as a scheduled digital output (*Schedule Digital Output* on page 369) is received.
Scheduled output becomes active at a specific target time or position, given by the Scheduled Digital Output command. Commands that schedule an event in the past will be ignored. An encoder value is in the future if the value will be reached by moving in the forward direction (the direction that encoder calibration was performed in).

To output an exposure signal:

1. Go to the **Output** page.
2. Click **Digital 1** or **Digital 2** in the **Output** panel.
3. Set **Trigger Event** to **Exposure Begin** or **Exposure End**.
4. Set the **Pulse Width** option.
The pulse width determines the duration of the digital output pulse, in microseconds.

To output an alignment signal:

1. Go to the **Output** page.
2. Click **Digital 1** or **Digital 2** in the **Output** panel.
3. Set **Trigger Event** to **Alignment**.
The digital output state is High if the sensor is aligned, and Low if not aligned. Whether the sensor is running does not affect the output.

To respond to exposure begin/end:

1. Go to the **Output** page.
2. Click **Digital 1** or **Digital 2** in the **Output** panel.

3. Set **Trigger Event** to **Exposure Begin** or **Exposure End**.

Analog Output

Gocator sensors can convert a measurement result or software request to an analog output. Each sensor supports one analog output channel.



Gocator 1300 series sensors are limited to sending data at 10 kHz over the analog output channel. Therefore, if you configure a sensor so that it runs at a speed higher than 10 kHz in the **Trigger** panel on the **Scan** page, and configure a measurement to be sent on the analog channel under **Analog** on the **Output** page, you will get analog data drops.

To achieve a 10 kHz analog output rate, you must check **Scheduled** on the **Output** page and configure scheduled output.

See *Analog Output* on page 545 for information on wiring analog output to an external device.

Send	Name	Id
<input type="radio"/>	None	
<input checked="" type="radio"/>	Range Position Z	0

To output measurement value or decision:

1. Go to the **Output** page.
2. Click on **Analog** in the **Output** panel.
3. Set **Trigger Event** to **Measurement**.
4. Select the measurement that should be used for output.
Only one measurement can be used for analog output. Measurements shown here correspond to measurements that have been programmed using the **Measurements** page.
5. Specify **Data Scale** values.
The values specified here determine how measurement values are scaled to the minimum and

maximum current output. The **Data Scale** values are specified in millimeters for dimensional measurements such as distance, square millimeters for areas, cubic millimeters for volumes, and degrees for angle results.

6. Specify **Current Range** and **Invalid** current values.
The values specified here determine the minimum and maximum current values in milliamperes. If **Invalid** is checked, the current value specified with the slider is used when a measurement value is not valid. If **Invalid** is not checked, the output holds the last value when a measurement value is not valid.
7. Specify if the output is immediate or scheduled.
An analog output can become active immediately or scheduled. Check the **Scheduled** option if the output needs to be scheduled.
A scheduled output becomes active after a specified delay from the start of Gocator exposure. A scheduled output can be used to track the decisions for multiple objects as these objects travel from the sensor to the eject gates. The delay specifies the distance from the sensor to the eject gates. An Immediate output becomes active as soon as the measurement results are available. The output activates after the Gocator finishes processing the data. As a result, the time between the start of Gocator exposure and output activates depends on the processing latency. The latency is reported in the dashboard and in the health messages.
8. Specify a delay.
The delay specifies the time or spatial location between the start of Gocator exposure and the output becomes active. The delay should be larger than the time needed to process the data inside the Gocator. It should be set to a value that is larger than the processing latency reported in the dashboard and in the health messages.
The unit of the delay is configured in the trigger panel. See *Triggers* on page 91 for details.

1. Go to the **Output** page.
2. Click on **Analog** in the **Output** panel.
3. Set **Trigger Event** to **Measurement**.
4. Select the measurement that should be used for output.
Only one measurement can be used for analog output. Measurements shown here correspond to measurements that have been programmed using the **Measurements** page.
5. Specify **Data Scale** values.
The values specified here determine how measurement values are scaled to the minimum and maximum current output. The **Data Scale** values are specified in millimeters for dimensional measurements such as distance, square millimeters for areas, cubic millimeters for volumes, and degrees for angle results.
6. Specify **Current Range** and **Invalid** current values.
The values specified here determine the minimum and maximum current values in milliamperes. If **Invalid** is checked, the current value specified with the slider is used when a measurement value is not valid. If **Invalid** is not checked, the output holds the last value when a measurement value is not valid.
7. Specify if the output is immediate or scheduled.
An analog output can become active immediately or scheduled. Check the **Scheduled** option if the

output needs to be scheduled.

A scheduled output becomes active after a specified delay from the start of Gocator exposure. A scheduled output can be used to track the decisions for multiple objects as these objects travel from the sensor to the eject gates. The delay specifies the distance from the sensor to the eject gates.

An Immediate output becomes active as soon as the measurement results are available. The output activates after the Gocator finishes processing the data. As a result, the time between the start of Gocator exposure and output activates depends on the processing latency. The latency is reported in the dashboard and in the health messages.

8. Specify a delay.

The delay specifies the time or spatial location between the start of Gocator exposure and the output becomes active. The delay should be larger than the time needed to process the data inside the Gocator. It should be set to a value that is larger than the processing latency reported in the dashboard and in the health messages.

The unit of the delay is configured in the trigger panel. See *Triggers* on page 91 for details.



The analog output takes about 75 us to reach 90% of the target value for a maximum change, then another ~40 us to settle completely.

To respond to software scheduled commands:

1. Go to the **Output** page.
2. Click on **Analog** in the **Output** panel.
3. Set **Trigger Event** to **Software**.
4. Specify if the output is immediate or scheduled.

An analog output value becomes active immediately or scheduled. Immediate output becomes active as soon as a Scheduled Analog Output command (see *Schedule Analog Output* on page 370) is received. Software scheduled command can schedule an analog value to output at a specified future time or encoder value, or changes its state immediately. The Delay setting in the panel is ignored. Commands that schedule event in the past will be ignored. An encoder value is in future if the value will be reached by moving in the forward direction (the direction that encoder calibration was performed in).

Serial Output

Gocator's web interface can be used to select measurements to be transmitted via RS-485 serial output. Each sensor has one serial output channel.

Two protocols are supported: ASCII Protocol and Selcom Serial Protocol.

The ASCII protocol outputs data asynchronously using a single serial port. For information on the ASCII Protocol parameters and data formats, see *ASCII Protocol* on page 467.

The Selcom Serial Protocol outputs synchronized serial data using two serial ports. For information on the Selcom serial protocol and data formats, see *Selcom Protocol* on page 478.

For information on wiring serial output to an external device, see *Serial Output* on page 544.

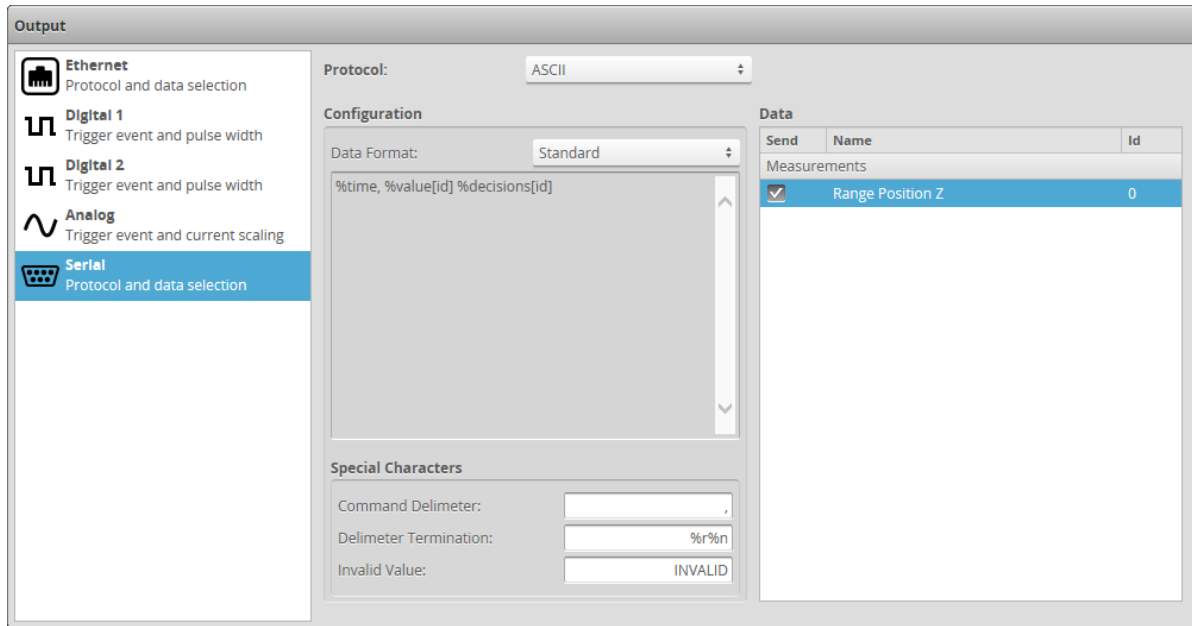

To configure ASCII output:

1. Go to the **Output** page.
2. Click on **Serial** in the **Output** panel.
3. Select **ASCII** in the **Protocol** option.
4. Select the **Data Format**.
 Select **Standard** to use the default result format of the ASCII protocol. Select value and decision to send by placing a check in the corresponding check box. See *Standard Result Format* on page 476 for an explanation of the standard result mode.
 Select **Custom** to customize the output result. A data format box will appear in which you can type the format string. See *Custom Result Format* on page 477 for the supported format string syntax.
5. Select the measurements to send.
 Select measurements by placing a check in the corresponding check box.
6. Set the **Special Characters**.
 Select the delimiter, termination and invalid value characters. Special characters are used in commands and standard-format data results.

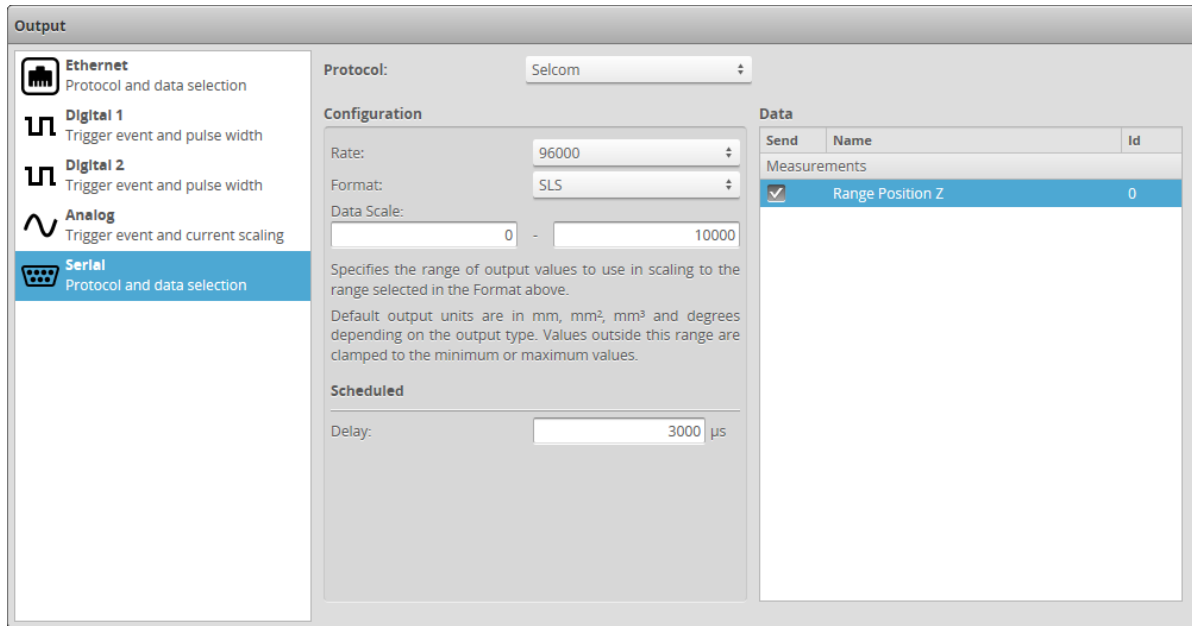

To configure Selcom output:

1. Go to the **Output** page.
2. Click on **Serial** in the **Output** panel.
3. Select **Selcom** in the **Protocol** option.
4. Select the measurements to send.
To select an item for transmission, place a check in the corresponding check box. Measurements shown here correspond to measurements that have been programmed using the **Measurements** page.
5. Select the baud rate in **Rate**.
6. Select the **Data Format**.
See *Selcom Protocol* on page 478 for definitions of the formats.
7. Specify **Data Scale** values.
The **Data Scale** values are specified in millimeters for dimensional measurements such as distance, square millimeters for areas, cubic millimeters for volumes, and degrees for angle results. The results are scaled according to the number of serial bits used to cover the data scale range. For example, the 12-bit output would break a 200 mm data scale range into 4096 increments (0.0488 mm/bit), and the 14-bit output would break a 200 mm data scale range into 16384 increments (0.0122 mm/bit).
8. Set the output delay in **Delay**.
The scheduled delay must be longer than the processing latency to prevent drops.

Dashboard

The following sections describe the **Dashboard** page.

Dashboard Page Overview

The **Dashboard** page summarizes sensor health information and provides measurement statistics. It also provides tool performance statistics. Use this information to troubleshoot your system.

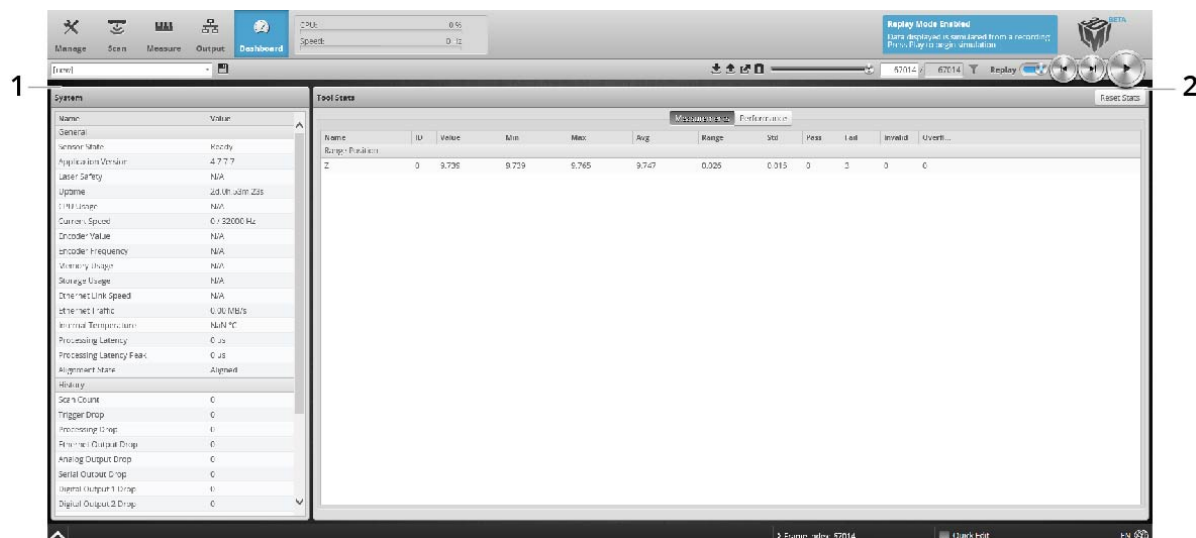

Element	Description	
1	System	Displays sensor state and health information. See <i>State and Health Information</i> below.
2	Tool Stats	Displays measurement and tool performance statistics. See <i>Statistics</i> on the next page.

State and Health Information

The following state and health information is available in the **System** panel on the **Dashboard** page:

Dashboard General System Values

Name	Description
Sensor State*	Current sensor state (Conflict, Ready, or Running).
Application Version	Sensor firmware version.
Laser Safety	Whether Laser Safety is enabled. With laser-based sensors, laser safety must be enabled in order to scan.
Uptime	Length of time since the sensor was power-cycled or reset.
CPU Usage	Sensor CPU utilization.
Current Speed*	Current speed of the sensor.
Encoder Value	Current encoder value (ticks).

Name	Description
Encoder Frequency	Current encoder frequency (Hz).
Memory Usage	Sensor memory utilization (MB used / MB total available).
Storage Usage	Sensor flash storage utilization (MB used / MB total available).
Ethernet Link Speed	Speed of the Ethernet link (Mbps).
Ethernet Traffic	Network output utilization (MB/sec).
Internal Temperature	Internal sensor temperature.
Processing Latency	Last delay from camera exposure start to when the results are ready for output.
Processing Latency Peak	Peak delay from camera exposure start to when the results are ready for output.
Alignment State	Whether the sensor or sensor system has been aligned.
Over Temperature State	Whether the internal temperature of the sensor is over a predetermined level.

Dashboard History Values

Name	Description
Scan Count*	Number of scans performed since sensor state last changed to Running.
Trigger Drop**	Count of camera frames dropped due to excessive trigger speed.
Processing Drop**	Count of frame drops due to excessive CPU utilization.
Ethernet Output Drop**	Count of frame drops due to slow Ethernet link.
Analog Output Drop**	Count of analog output drops because last output has not been completed.
Serial Output Drop**	Count of serial output drops because last output has not been completed.
Digital Output 1 Drop**	Count of digital output drops because last output has not been completed.
Digital Output 2 Drop**	Count of digital output drops because last output has not been completed.
Digital Output 1 High Count	Count of high states on digital output.
Digital Output 2 High Count	Count of high states on digital output.
Digital Output 1 Low Count	Count of low states on digital output.
Digital Output 2 Low Count	Count of low states on digital output.
Anchor Invalid Count**	Count of invalid anchors.
Valid Spot Count	Count of valid spots detected in the last frame.
Max Spot Count*	Maximum number of spots detected since sensor was started.
Camera Search Count	Not applicable to these sensors.

* When the sensor is accelerated, the indicator's value is reported from the accelerating PC.

** When the sensor is accelerated, the indicator's value is the sum of the values reported from the sensor and the accelerating PC.

Statistics

In the **Tool Stats** pane, you can examine measurement and tool statistics in two tabs: **Measurements** and **Performance**.

To reset statistics in both tabs, use the **Reset Stats** button.

Measurements

The **Measurements** tab displays statistics for each measurement enabled in the **Measure** page, grouped by the tool that contains the measurement.

Tool Stats											
Measurements											Performance
Name	ID	Value	Min	Max	Avg	Range	Std	Pass	Fail	Invalid	Overflow
Profile Area											
Centroid X	1	-13.803	-13.803	-13.803	-13.803	0	0	0	1	0	0
Area	2	0.083	0.083	0.083	0.083	0	0	0	1	0	0
Profile Line											
Offset	3	0.074	0.074	0.074	0.074	0	0	0	1	0	0
Angle	4	-0.062	-0.062	-0.062	-0.062	0	0	0	1	0	0
Profile Position											
X	5	-8.448	-8.448	-8.448	-8.448	0	0	0	1	0	0
Z	6	0.118	0.118	0.118	0.118	0	0	0	1	0	0

For each measurement, Gocator displays the following information:

Measurement Statistics

Name	Description
ID	The measurement ID as set in the measurement's ID field on the Measure page .
Value	The most recent measurement value.
Min	The minimum measurement value that has been observed.
Max	The maximum measurement value that has been observed.
Avg	The average of all measurement values collected since the sensor was started.
Range	The difference between Max and Min.
Std	The standard deviation of all measurement values collected since the sensor was started.
Pass	The number of pass decisions the measurement has generated.
Fail	The number of fail decisions the measurement has generated.
Invalid	The number of frames that returned no valid measurement value.
Overflow	The number of frames that returned an overflow.

Performance

The **Performance** tab displays performance statistics (execution time) for each tool added in the **Measure** page.

Tool Stats					
Measurements					Performance
Name	Last (ms)	Min (ms)	Max (ms)	Avg (ms)	▼ Avg (%)
Profile Area	0.022	0.006	0.098	0.025	21.3
Profile Line	0.013	0.006	0.123	0.016	13.9
Profile Position	0.006	0.004	0.046	0.007	6.1

For each tool, Gocator displays the following information:

Performance Statistics

Name	Description
Last (ms)	The last execution time of the tool.

Name	Description
Min (ms)	The minimum execution time of the tool.
Max (ms)	The maximum execution time of the tool.
Avg (ms)	The average execution time of the tool.
Avg (%)	The average percentage the CPU the tool uses.

 Tools are sorted by the *Avg (%)* column in descending order.

Gocator Emulator

The emulator is a stand-alone application that lets you run a "virtual" sensor, encapsulated in a "scenario." When running a scenario, you can test jobs, evaluate data, and even learn more about new features, rather than take a physical device off the production line to do this. You can also use a scenario to familiarize yourself with the overall interface if you are new to Gocator.



*Emulator showing a range in recorded data.
A measurement is applied to the recorded data.*

System Requirements

The following are the system requirements for the software:

PC

- Processor: Intel Core i3 or equivalent (64-bit)
- RAM: 4 GB
- Hard drive: 500 GB
- Operating system: Windows 7 or higher (64-bit)

Limitations

In most ways, a scenario behaves like a real sensor, especially when visualizing data, setting up models and part matching, and adding and configuring measurement tools. The following are some of the limitations:

- Changes to job files in the emulator are *not* persistent (they are lost when you close or restart the emulator). However, you can keep a modified job by first [saving](#) it and then [downloading](#) it from the **Jobs** list on the **Manage** page to a client computer. The job file can then be loaded into the emulator at a later time or even onto a physical sensor for final testing.
- Performing alignment in the emulator has no effect and will never complete.
- The emulator does not support the PROFINET protocol.

For information on saving and loading jobs in the emulator, see *Creating, Saving, and Loading Jobs* on page 257.

For information on uploading and downloading jobs between the emulator and a computer, and performing other job file management tasks, see *Downloading and Uploading Jobs* on page 262.

Downloading a Support File

The emulator provides several preinstalled scenarios.

You can also create scenarios yourself by downloading a support file from a physical sensor and then adding it to the emulator.

Support files can contain jobs, letting you configure systems and add measurements in an emulated sensor. Support files can also contain replay data, letting you test measurements and some configurations on real data. Dual-sensor systems are supported.

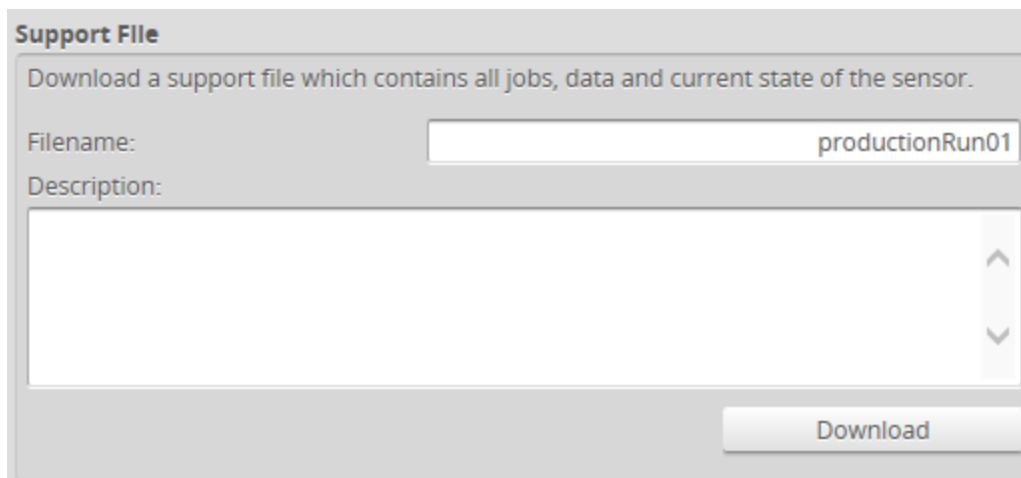

Support File

Download a support file which contains all jobs, data and current state of the sensor.

Filename:

Description:

Download

To download a support file:

1. Go to the **Manage** page and click on the **Support** category.
2. In **Filename**, type the name you want to use for the support file.

When you create a scenario from a support file in the emulator, the filename you provide here is displayed in the emulator's scenario list.

Support files end with the .gs extension, but you do not need to type the extension in **Filename**.

3. (Optional) In **Description**, type a description of the support file.

When you create a scenario from a support file in the emulator, the description is displayed below the emulator's scenario list.

4. Click **Download**, and then when prompted, click **Save**.

 Downloading a support file stops the sensor.

Running the Emulator

The emulator is contained in the utilities package (14405-x.x.x.x_SOFTWARE_GO_Uilities.zip). To get the package, go to <http://lmi3d.com/support>, choose your product from the Product Downloads section, and download the package from the Download Center.

To run the emulator, unzip the package and double-click the *GoEmulator* link in the unzipped *Emulator and Accelerator* subfolder.

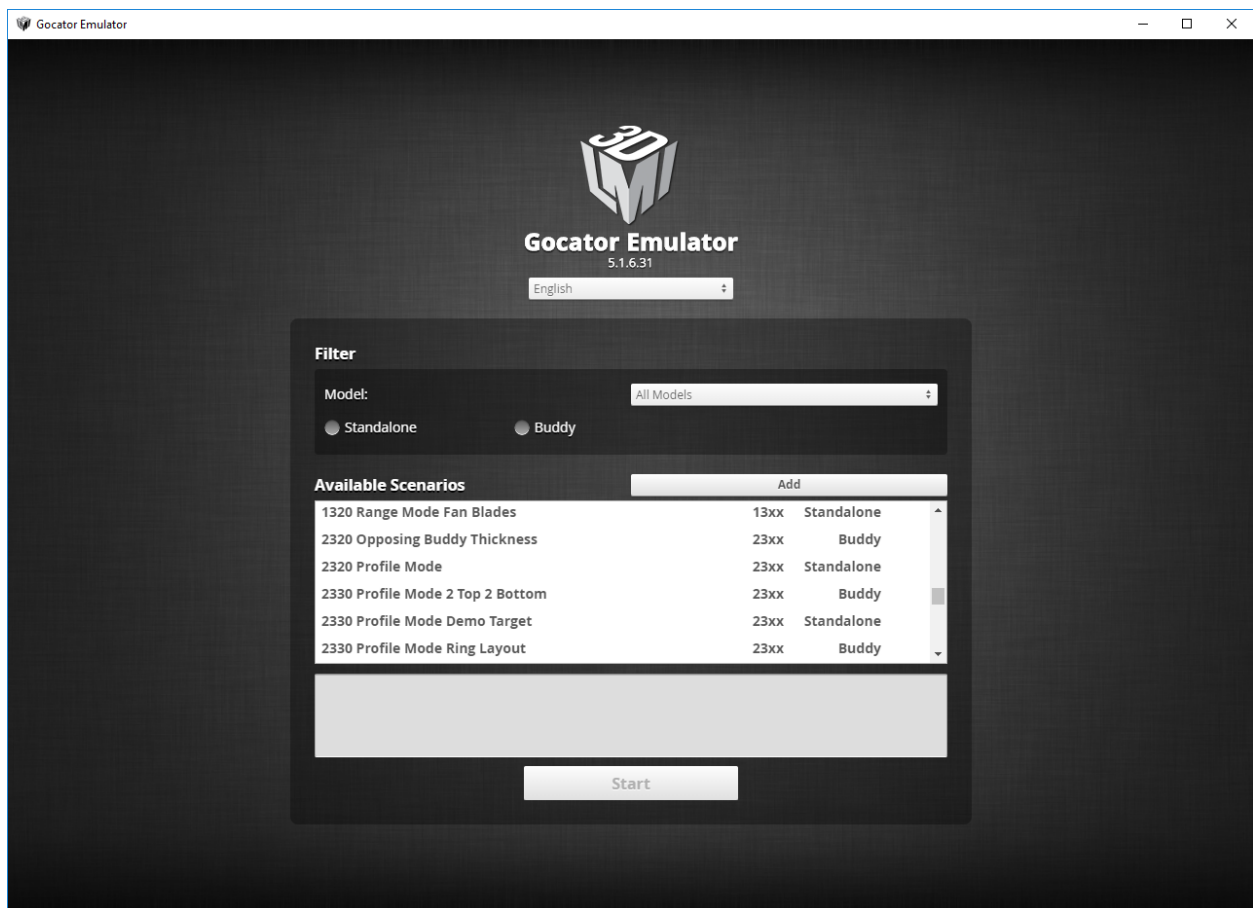

Emulator launch screen

You can change the language of the emulator's interface from the launch screen. To change the language, choose a language option from the top drop-down:



Selecting the emulator interface language

Adding a Scenario to the Emulator

To simulate a physical sensor using a support file downloaded from a sensor, you must add it as a scenario in the emulator.

You can add support files downloaded from any series of Gocator sensors to the emulator.

To add a scenario:

1. Launch the emulator if it isn't running already.
2. Click the **Add** button and choose a previously saved support file (.gs extension) in the **Choose File to Upload** dialog.



3. (Optional) In **Description**, type a description.

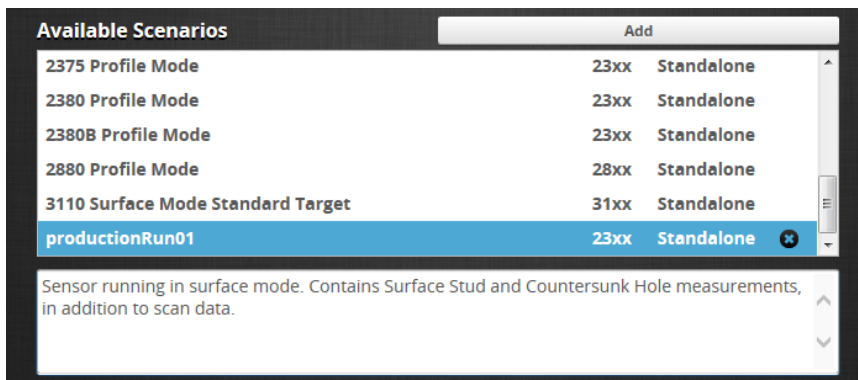

You can only add descriptions for user-added scenarios.

Running a Scenario

After you have added a virtual sensor by uploading a support file to the emulator, you can run it from the **Available Scenarios** list on the emulator launch screen. You can also run any of the scenarios included in the installation.

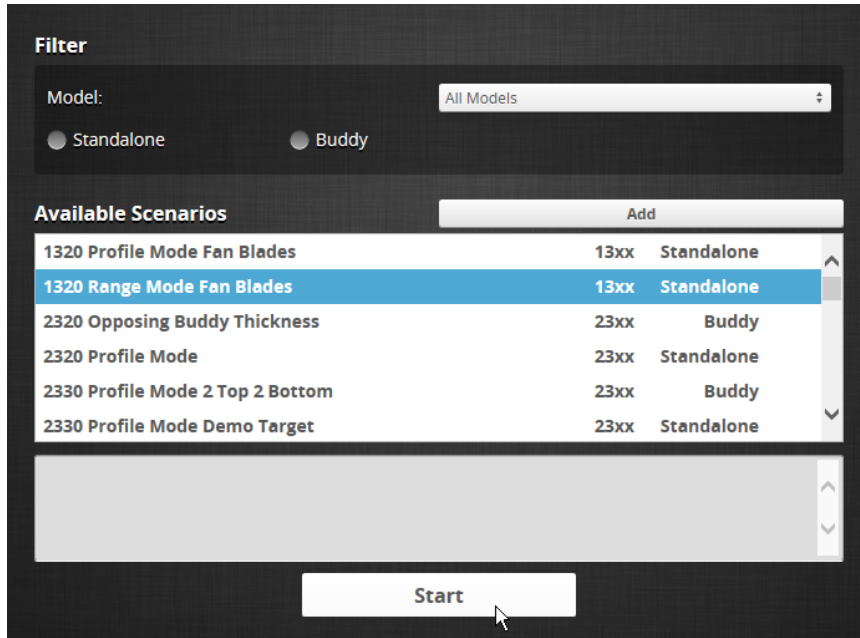

To run a scenario:

1. If you want to filter the scenarios listed in **Available Scenarios**, do one or both of the following:
 - Choose a model family in the **Model** drop-down.
 - Choose **Standalone** or **Buddy** to limit the scenarios to single-sensor or dual-/multi-sensor scenarios, respectively.
2. Select a scenario in the **Available Scenarios** list and click **Start**.

Removing a Scenario from the Emulator

You can easily remove a scenario from the emulator.

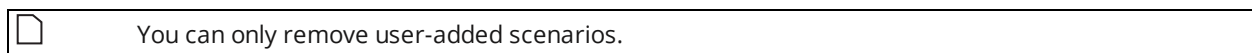

To remove a scenario:

1. If the emulator is running a scenario, click **Stop Emulation** to stop it.
2. In the **Available Scenarios** list, scroll to the scenario you want to remove.

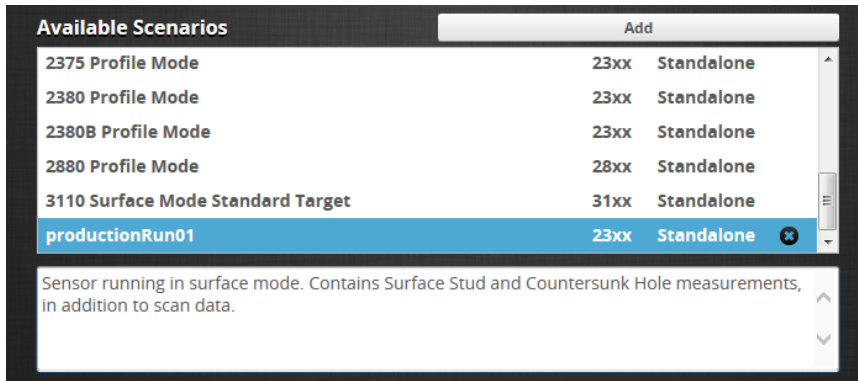

3. Click the  button next to the scenario you want to remove.

The scenario is removed from the emulator.

Using Replay Protection

Making changes to certain settings on the **Scan** page causes the emulator to flush replay data. The **Replay Protection** option protects replay data by preventing changes to settings that affect replay data. Settings that do not affect replay data can be changed.

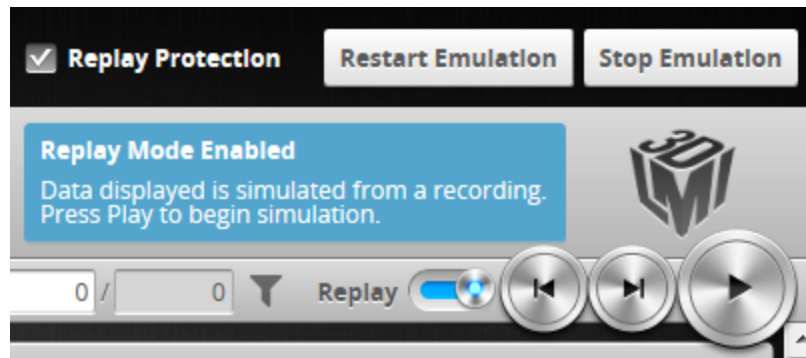

If you try to uncheck **Replay Protection**, you must confirm that you want to disable it.

Replay Protection is on by default.

Stopping and Restarting the Emulator

To stop the emulator:

- Click **Stop Emulation**.

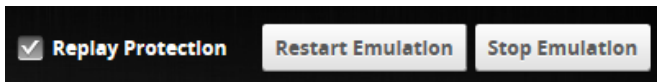

Stopping the emulator returns you to the launch screen.

To restart the emulator when it is running:

- Click **Restart Emulation**.

Restarting the emulator restarts the currently running simulation.

Running the Emulator in Default Browser

When you use the `/browser` command line parameter, the emulator application launches normally but also launches in your default browser. This provides additional flexibility when using the emulator. For example, you can resize the emulator running in a browser window.

To run the emulator in your default browser:

1. In Windows Explorer (Windows 7) or File Explorer (Windows 8 or 10), browse to the location of the emulator. The emulator is under `bin\win64`, in the location in which you installed the emulator.
2. Press and hold `Shift`, right-click the `win64` folder containing the emulator, and choose **Open command window here** (or **Open PowerShell window here**).

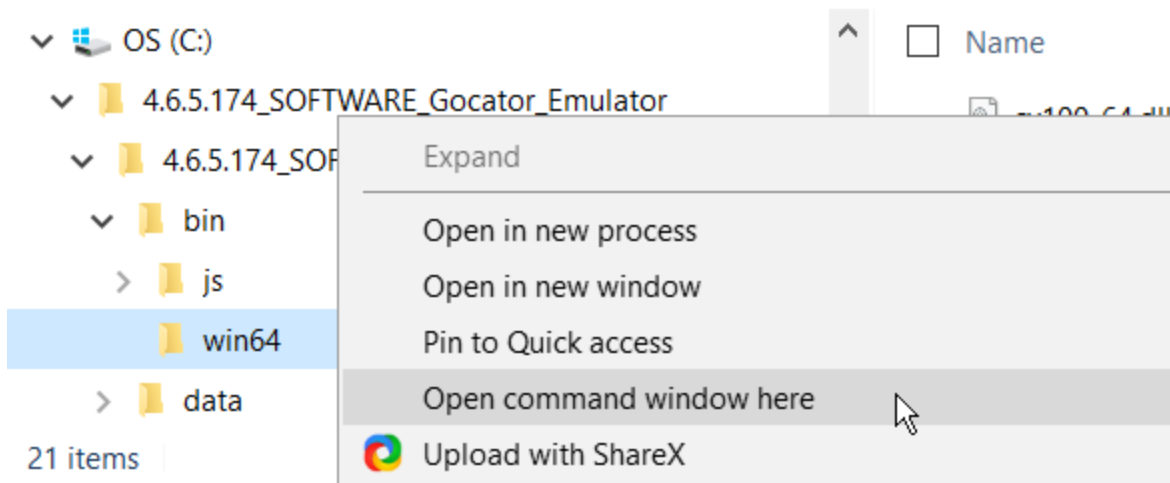

3. In the command prompt, type `GoEmulator.exe /browser` (or `.\GoEmulator.exe /browser` for PowerShell).

```
C:\WINDOWS\system32\cmd.exe
C:\4.6.5.174_SOFTWARE_Gocator_Emulator\4.6.5.174_SOFTWARE_Gocator_Emulator\bin\win64>GoEmulator.exe /browser
```

After the emulator application starts, the emulator also launches in your default browser.

Working with Jobs and Data

The following topics describe how to work with jobs and replay data (data recorded from a physical sensor) in a scenario running on the emulator.

Creating, Saving, and Loading Jobs

Changes saved to job files in the emulator are *not* persistent (they are lost when you close or restart the emulator). To keep jobs permanently, you must first save the job in the emulator and then download the job file to a client computer. See below for more information on creating, saving, and switching jobs. For information on downloading and uploading jobs between the emulator and a computer, see *Downloading and Uploading Jobs* on page 262.

The job drop-down list in the toolbar shows the jobs available in the emulator. The job that is currently active is listed at the top. The job name will be marked with "[unsaved]" to indicate any unsaved changes.



To create a job:

1. Choose **[New]** in the job drop-down list and type a name for the job.
2. Click the **Save** button  or press **Enter** to save the job.
The job is saved to the emulator using the name you provided.

To save a job:

- Click the **Save** button .
- The job is saved to the emulator.

To load (switch) jobs:

- Select an existing file name in the job drop-down list.
- The job is activated. If there are any unsaved changes in the current job, you will be asked whether you want to discard those changes.

Playback and Measurement Simulation

The emulator can replay scan data previously recorded by a physical sensor, and also simulate measurement tools on recorded data. This feature is most often used for troubleshooting and fine-tuning measurements, but can also be helpful during setup.

Playback is controlled using the toolbar controls.

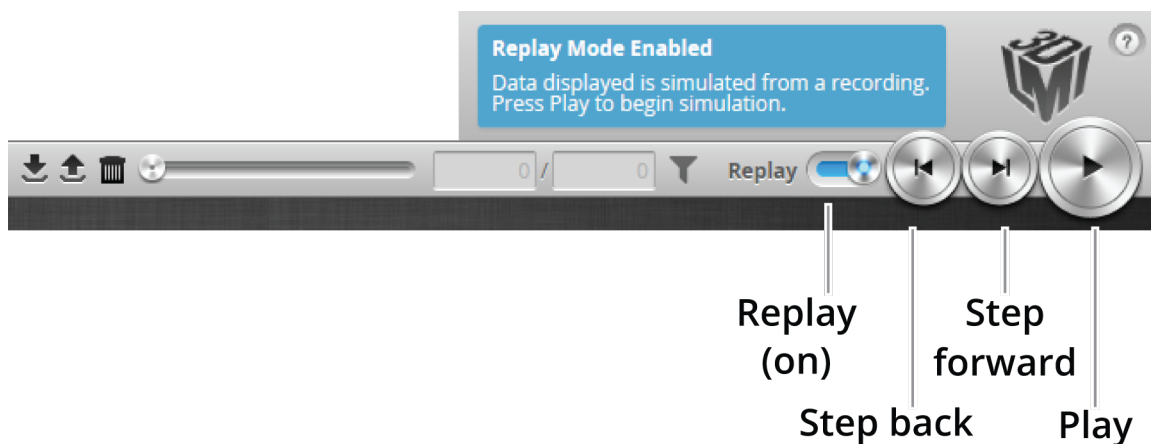
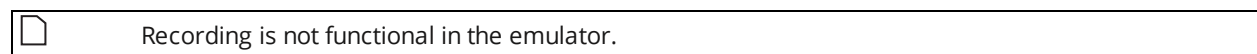

To replay data:

1. Toggle **Replay** mode on by setting the slider to the right in the **Toolbar**.
The slider's background turns blue.
To change the mode, you must uncheck **Replay Protection**.

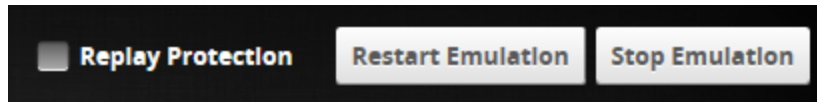

2. Use the **Replay** slider or the **Step Forward**, **Step Back**, or **Play** buttons to review data.
The **Step Forward** and **Step Back** buttons move the current replay location forward and backward by a single frame, respectively.
The **Play** button advances the replay location continuously, animating the playback until the end of the replay data.
The **Stop** button (replaces the **Play** button while playing) can be used to pause the replay at a particular location.
The **Replay** slider (or **Replay Position** box) can be used to go to a specific replay frame.

To simulate measurements on replay data:

1. Toggle **Replay** mode on by setting the slider to the right in the **Toolbar**.
The slider's background turns blue.
To change the mode, **Replay Protection** must be unchecked.
2. Go to the **Measure** page.
Modify settings for existing measurements, add new measurement tools, or delete measurement tools as desired. For information on adding and configuring measurements, see *Measurement and Processing* on page 127.
3. Use the **Replay Slider**, **Step Forward**, **Step Back**, or **Play** button to simulate measurements.
Step or play through recorded data to execute the measurement tools on the recording.
Individual measurement values can be viewed directly in the data viewer. Statistics on the measurements that have been simulated can be viewed in the **Dashboard** page; for more information on the dashboard, see *Dashboard* on page 247.

To clear replay data:

- Click the **Clear Replay Data** button .

Downloading, Uploading, and Exporting Replay Data

Replay data (recorded scan data) can be downloaded from the emulator to a client computer, or uploaded from a client computer to the emulator.

Data can also be exported from the emulator to a client computer in order to process the data using third-party tools.

 You can only upload replay data to the same sensor model that was used to create the data.

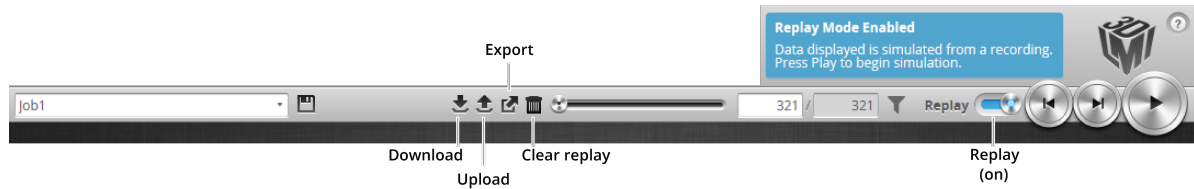

Replay data is not loaded or saved when you load or save jobs.

To download replay data:

1. Click the Download button .
2. In the **File Download** dialog, click **Save**.
3. In the **Save As...** dialog, choose a location, optionally change the name, and click **Save**.

To upload replay data:

1. Click the Upload button .
The Upload menu appears.

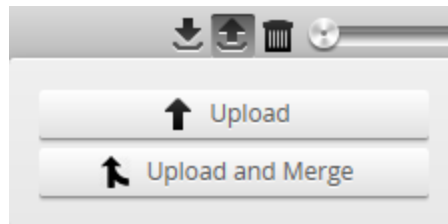

2. In the Upload menu, choose one of the following:
 - **Upload:** Unloads the current job and creates a new unsaved and untitled job from the content of the replay data file.
 - **Upload and merge:** Uploads the replay data and merges the data's associated job with the current job. Specifically, the settings on the **Scan** page are overwritten, but all other settings of the current job are preserved, including any measurements.

If you have unsaved changes in the current job, the firmware asks whether you want to discard the changes.

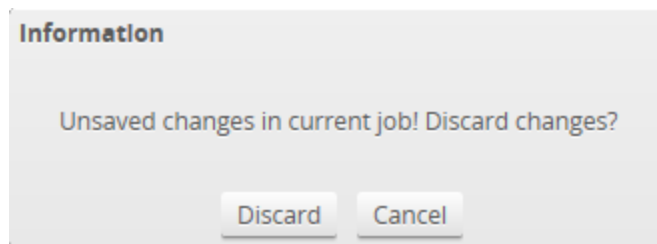

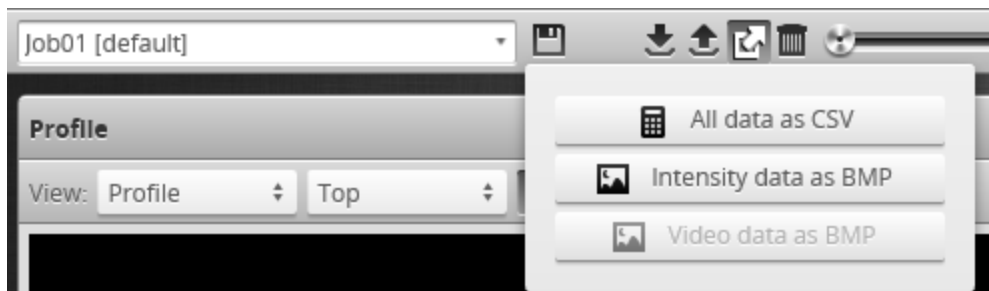

3. Do one of the following:
 - Click **Discard** to discard any unsaved changes.
 - Click **Cancel** to return to the main window to save your changes.
4. If you clicked **Discard**, navigate to the replay data to upload from the client computer and click **OK**.
The replay data is loaded, and a new unsaved, untitled job is created.

Replay data can be exported using the CSV format. If you have enabled **Acquire Intensity** in the **Scan Mode** panel on the **Scan** page, the exported CSV file includes intensity data.



To export replay data in the CSV format:

1. In the **Scan Mode** panel, switch to Range or Profile.
2. Switch to Replay mode.
3. Click the Export button  and select **All Data as CSV**.
In Profile mode, all data in the record buffer is exported. data at the current replay location is exported. Use the playback control buttons to move to a different replay location; for information on playback, see *To replay data in Playback and Measurement Simulation* on page 258.
4. (Optional) Convert exported data to another format using the CSV Converter Tool. For information on this tool, see *CSV Converter Tool* on page 505.

 The decision values in the exported data depend on the *current* state of the job, not the state during recording. For example, if you record data when a measurement returns a *pass* decision, change the measurement's settings so that a *fail* decision is returned, and then export to CSV, you will see a *fail* decision in the exported data.

Recorded intensity data can be exported to a bitmap (.BMP format). **Acquire Intensity** must be checked in the **Scan Mode** panel while data was being recorded in order to export intensity data.

To export recorded intensity data to the BMP format:

- Switch to Replay mode and click the **Export** button  and select **Intensity data as BMP**.
Only the intensity data in the current replay location is exported. Use the playback control buttons to move to a different replay location; for information on playback, see *To replay data in Playback and Measurement Simulation* on page 258.

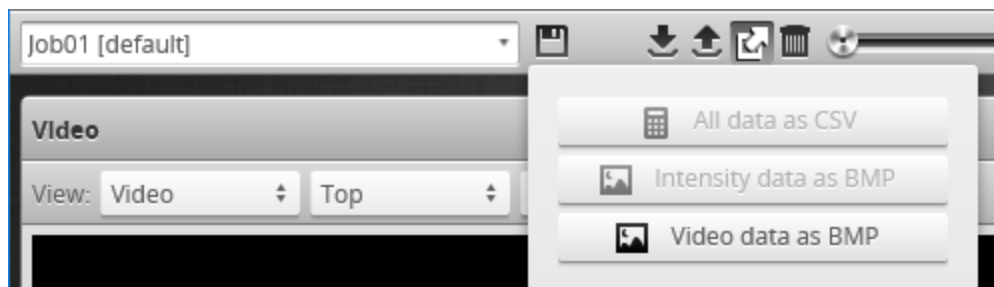

To export video data to a BMP file:

1. In the **Scan Mode** panel, switch to Video mode.
Use the playback control buttons to move to a different replay location; for information on playback, see *To replay data in Playback and Measurement Simulation* on page 258.
2. Switch to Replay mode.
3. Click the Export button  and select **Video data as BMP**.

Downloading and Uploading Jobs

The **Jobs** category on the **Manage** page lets you manage the jobs in the emulator.

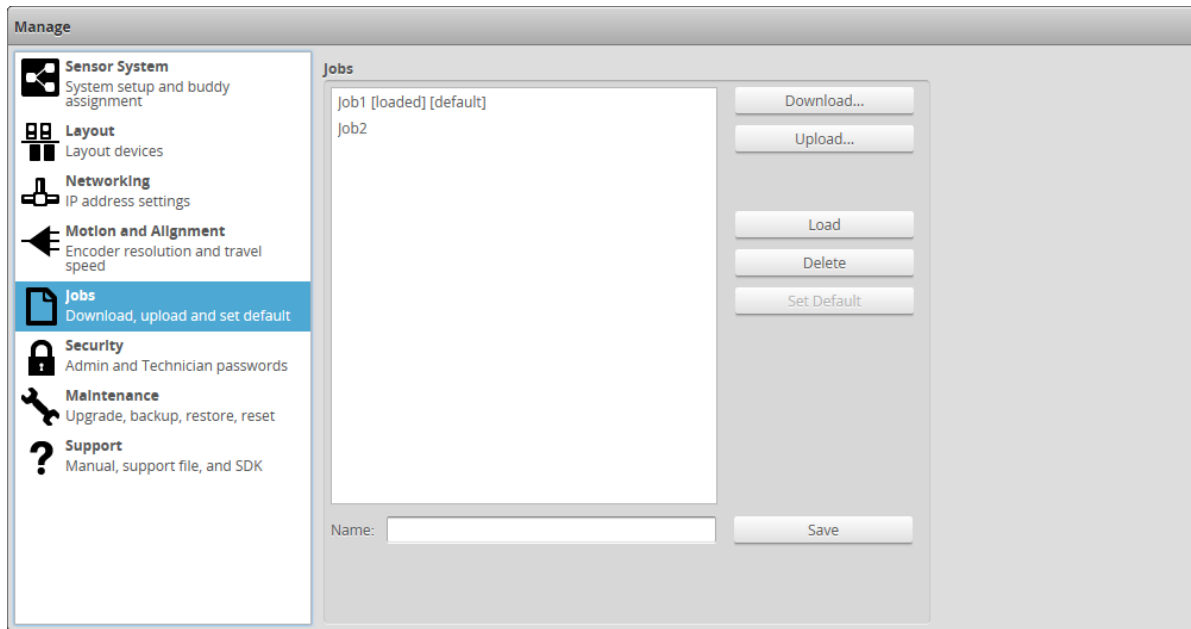

Element	Description
Name field	Used to provide a job name when saving files.
Jobs list	Displays the jobs that are currently saved in the emulator.
Save button	Saves current settings to the job using the name in the Name field. Changes to job files are not persistent in the emulator. To keep changes, first save changes in the job file, and then download the job file to a client computer. See the procedures below for instructions.
Load button	Loads the job that is selected in the job list. Reloading the current job discards any unsaved changes.
Delete button	Deletes the job that is selected in the job list.
Set as Default button	Setting a different job as the default is not persistent in the emulator. The job set as default when the support file (used to create a virtual sensor) was downloaded is used as the default whenever the emulator is started.
Download... button	Downloads the selected job to the client computer.

Element	Description
Upload... button	Uploads a job from the client computer.

Unsaved jobs are indicated by "[unsaved]".

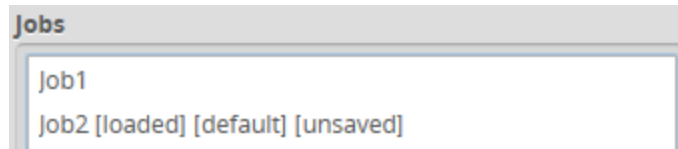

 Changes to job files in the emulator are *not* persistent (they are lost when you close or restart the emulator). However, you can keep modified jobs by first saving them and then downloading them to a client computer.

To save a job:

1. Go to the **Manage** page and click on the **Jobs** category.
2. Provide a name in the **Name** field.
To save an existing job under a different name, click on it in the **Jobs** list and then modify it in the **Name** field.
3. Click on the **Save** button or press **Enter**.

To download, load, or delete a job, or to set one as a default, or clear a default:

1. Go to the **Manage** page and click on the **Jobs** category.
2. Select a job in the **Jobs** list.
3. Click on the appropriate button for the operation.

Scan, Model, and Measurement Settings

The settings on the **Scan** page related to actual scanning will clear the buffer of any scan data that is uploaded from a client computer, or is part of a support file used to create a virtual sensor. If **Replay Protection** is checked, the emulator will indicate in the log that the setting can't be changed because the change would clear the buffer. For more information on Replay Protection, see *Using Replay Protection* on page 256.

Other settings on the **Scan** page related to the post-processing of data can be modified to test their influence on scan data, without modifying or clearing the data, for example edge filtering and filters on the X axis. Note that modifying the Y filters causes the buffer to be cleared. (For more information on these features, see the Gocator Laser Profile Sensors user manual.)

For information on creating models and setting up part matching, see *Models and Part Matching* in the Gocator 2100, 2300 and 2880 user manual. For information on adding and configuring measurement tools, see *Measurement and Processing* on page 127.

Calculating Potential Maximum Frame Rate

You can use the emulator to calculate the potential maximum frame rate you can achieve with different settings.

For example, when you reduce the active area, in the **Active Area** tab on the **Sensor** panel, the maximum frame rate displayed on the **Trigger** panel is updated to reflect the increased speed that would be available in a physical sensor. (See *Active Area* on page 98 for more information on active area.)

Similarly, you can adjust exposure on the **Exposure** tab on the **Sensor** panel to see how this affects the maximum frame rate. (See *Exposure* on page 101 for more information on exposure.)

 To adjust active area in the emulator, **Replay Protection** must be turned off. See *Using Replay Protection* on page 256 for more information.

 Saving changes to active area causes replay data to be flushed.

Protocol Output

The emulator simulates output for all of Gocator's Ethernet-based protocols, with the exception of PROFINET.

- [Gocator](#)
- [ASCII](#)
- [Modbus](#)
- [EtherNet/IP](#)

Clients (such as PLCs) can connect to the emulator to access the simulated output and use the protocols as they would with a physical sensor.

The emulator allows connections to emulated sensors on localhost (127.0.0.1). You can also allow connections to emulated sensors on your computer's network card; for more information, see *Remote Operation* below.

Remote Operation

You can specify the IP address of one of your computer's network cards to allow clients to connect remotely to an emulated sensor using the `/ip` command line parameter. When the `/ip` parameter is not used, emulated sensors are only available on the local machine (that is, 127.0.0.1 or localhost).

 Clients can only connect to emulated sensors, not to the emulator's launch page.

 You may need to contact your network administrator to allow connections to the computer running the emulated sensor.

To allow remote connections to an emulated sensor:

1. In Windows Explorer (Windows 7) or File Explorer (Windows 8 or 10), browse to the location of the emulator. The emulator is under `bin\win64`, in the location in which you installed the emulator.

2. Press and hold `Shift`, right-click the `win64` folder containing the emulator, and choose **Open command window here** (or **Open PowerShell window here**).

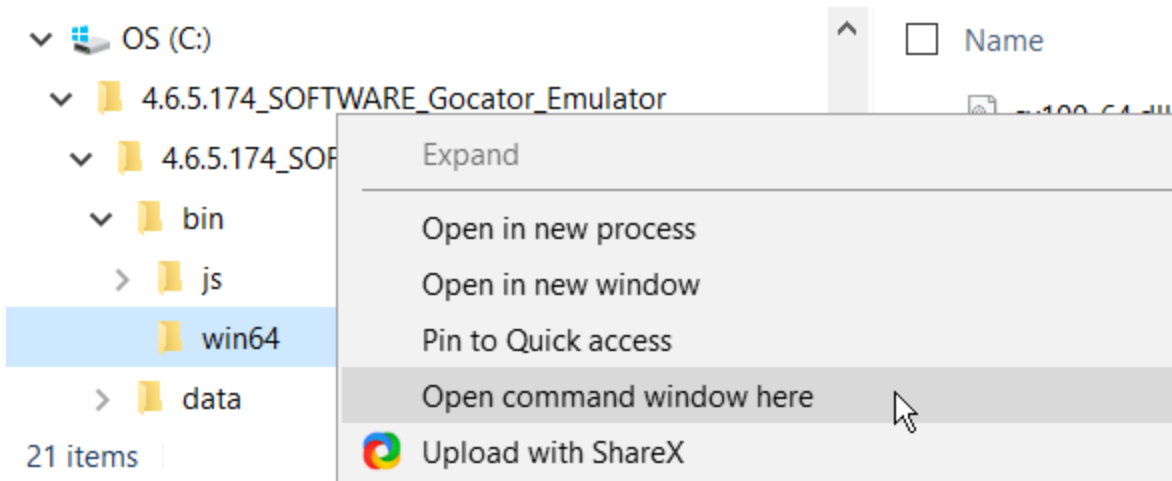

3. In the command prompt, type `GoEmulator.exe /ip`, followed by a valid IPV4 address on your network.

```
C:\WINDOWS\system32\cmd.exe
C:\4.6.5.174_SOFTWARE_Gocator_Emulator\4.6.5.174_SOFTWARE_Gocator_Emulator\bin\win64>GoEmulator.exe /ip 192.168.1.42_
```

The emulator application starts.

The emulator does not check that the IP address is valid.

4. From the emulator launch page, start a scenario.
For more information, see *Running a Scenario* on page 255.
5. Provide the IP address you used with the `/ip` parameter, followed by port number 3191, to users who want to connect to the emulated sensor, for example:

```
192.168.1.42:3191
```

Gocator Accelerator

The Gocator accelerator improves a Gocator system's processing capability by transferring the processing to a PC in the system. It can accelerate one or more standalone sensors or multi-sensor systems.

The Gocator emulator and accelerator do not support the PROFINET protocol.

You can implement acceleration capabilities in client applications that you create using the [Gocator SDK](#). LMI also provides a standalone utility (GoAccelerator.exe) that you can use to accelerate systems.

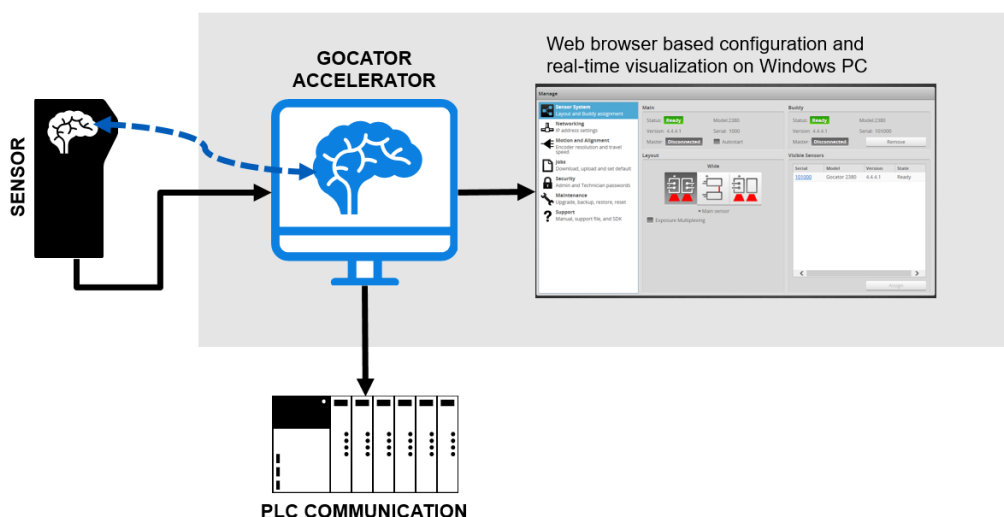

The [web interface](#) on an accelerated sensor is identical to the interface on an unaccelerated sensor. The Ethernet-based [output protocols](#) (Gocator, EtherNet/IP, ASCII, and Modbus) are also identical to those found on an unaccelerated sensor, and are fully supported.

The Gocator Accelerator supports digital, analog, and serial output from sensors. However, because output must be passed to the PC and then back to the sensor, network latency will have an impact on performance.

The firmware version of the sensor you want to accelerate must match the version of the SDK used to build an accelerator-based application (or the version of the GoAccelerator utility).

When a sensor is accelerated, it sends data directly to the accelerating application. Users access the Gocator web interface using the IP address of the computer running the application, rather than the IP of the sensor.

Some health indicators behave differently when a sensor is accelerated. For information on

which indicators in the Dashboard that acceleration affects, see *State and Health Information* on page 247. For information on which indicators available through the Gocator protocol acceleration affects, see *Health Results* on page 396.

Once a system is accelerated, an SDK application can interface to the accelerator application the same way as is possible with a physical sensor, although the IP of the accelerating PC must be used for the connection.

System Requirements and Recommendations

The following are the minimum system requirements for accelerating a single sensor with the Gocator accelerator PC application:

PC

- Processor: Intel Core i3 or equivalent (32- or 64-bit)
- RAM: 4 GB
- Hard drive: 128 GB
- Operating system: Windows 7 or higher (32- or 64-bit)

To accelerate more sensors or run the system at higher speeds, use a computer with greater system resources.

The following are general recommendations:

- Run only the accelerator application on the PC: third-party applications can consume system resources in unpredictable ways and at random times.
- Limit background Windows processes such as drive optimization (defragmentation) or virus scans, or schedule them so that they don't interfere with scanning sessions.
- Ensure that sufficient overhead in the system's resources is available. You can review the PC's resources with the Windows Task Manager and Resource Monitor applications. We recommend that you leave at least 20% network bandwidth, CPU, memory and disk utilization at all times.
- To verify system stability and robustness, perform long-term testing over multiple days.

Benefits

Accelerated sensors provide several benefits.

Acceleration is completely transparent: because the output protocols of an accelerated sensor are identical to those of an unaccelerated sensor, SDK and PLC applications require no changes whatsoever for controlling accelerated sensors and receiving health information and data.

Measurement latency is reduced on accelerated sensors, which results in shorter cycle times. This means a sensor can scan more targets in a given time period.

The memory of accelerated sensors is limited only by the memory of the PC on which the Accelerator is running.

Installation

To get the necessary packages, go to <http://lmi3d.com/support>, choose your product from the Product Downloads section, and download it from the Download Center.

- For the GoAccelerator utility, download the 14405-x.x.x.x_SOFTWARE_GO_Uilities.zip package.
- For the SDK libraries and DLL for integrating acceleration into a client application, download the 14400-X.X.X.X_SOFTWARE_GO_SDK.zip.

Gocator Accelerator Utility

The Gocator Accelerator utility accelerates the standalone sensors or multi-sensor systems you choose.

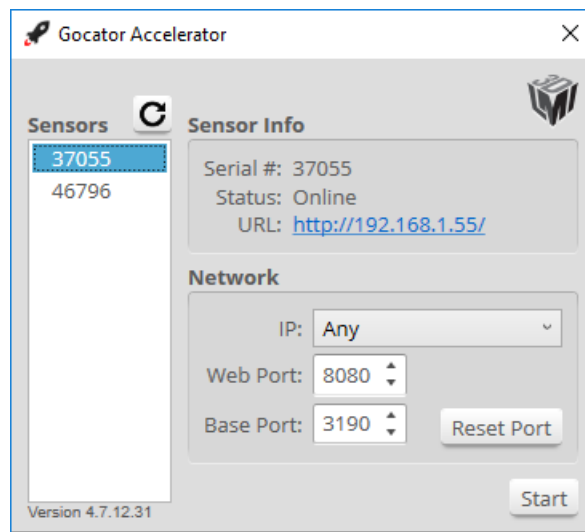

To accelerate a sensor using the Gocator Accelerator utility:

1. Power up the sensor system you want to accelerate.
2. Launch the Gocator Accelerator utility.
3. If a Windows Security alert asks whether you want to allow GoAccelerator.exe to communicate on networks, make sure **Public** and **Private** are checked, and then click **Allow Access**.
4. In the **Sensors** list, click the sensor you want to accelerate.

If you do not see the sensor, you may need to wait a few seconds and then click the Refresh button ().

In multi-sensor systems, only the Main sensor is listed.

5. (Optional) In the **IP** drop-down, choose an IP or choose **Any** to let the application choose.

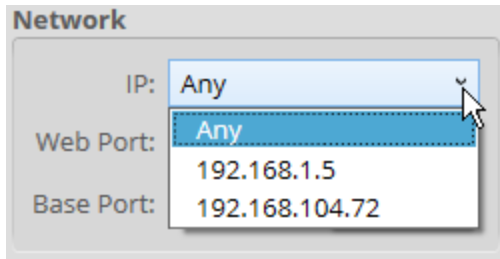

- (Optional) Set **Web Port** to a port for use with the accelerated sensor's URL.

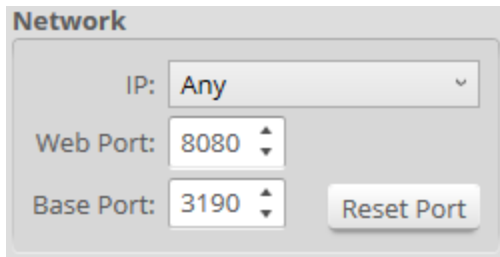

 If port 8080 is already in use, set **Web Port** to an unused port.

- (Optional) If you are accelerating multiple systems, click on another sensor in the **Sensors** list, and repeat the steps above.

The application uses **Base Port** as an offset for several communication port numbers.

To avoid port conflicts, you should increment the base port number by at least 10 for each accelerated sensor.

Port 3190 is the default base port number, allowing connections from SDK-based applications and the web UI without manually specifying ports.

- Click **Start**.

The sensor system is now accelerated. An icon appears next to the accelerated sensor in the **Sensors** list to indicate this.

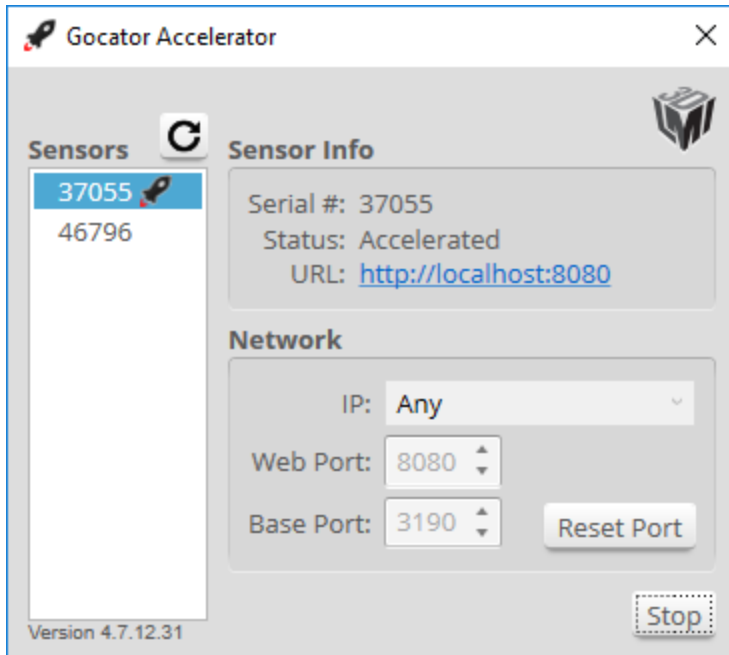

- To open the accelerated sensor's web interface, in the Gocator Accelerator application, click the link next to **URL**.

When a sensor is accelerated, a "rocket" icon appears in the [metrics area](#).



 If you restart an accelerated sensor, the sensor will continue to be accelerated when it restarts.

To stop an accelerated sensor in the Gocator Accelerator application:

- Select the sensor in the **Sensors** list.
- Click **Stop**.

To exit the Gocator Accelerator application:

- Right-click the icon Gocator Accelerator icon () in the notification tray.
Clicking the X icon in the application only minimizes the application.
- Choose **Exit**.

Dashboard and Health Indicators

After a sensor is accelerated, the values of some health indicators come from the accelerating PC instead of the sensor. Others come from a combination of the accelerated sensor and the accelerating PC.

- For information on which indicators are affected in the Dashboard in the web interface, see *State and Health Information* on page 247.

- For information on which indicators accessed through the Gocator protocol are affected, see *Health Results* on page 396.

SDK Application Integration

Gocator acceleration can be fully integrated into an SDK application. Users simply need to instantiate the GoAccelerator object and connect it to a sensor object.

```
GoAccelerator accelerator = kNULL;

// obtain GoSensor object by sensor IP address
if ((status = GoSystem_FindSensorByIpAddress(system, &ipAddress, &sensor)) != kOK)
{
    printf("Error: GoSystem_FindSensorByIpAddress:%d\n", status);
    return;
}

// construct accelerator
if ((status = GoAccelerator_Construct(&accelerator, kNULL)) != kOK)
{
    printf("Error: GoAccelerator_Construct:%d\n", status);
    return;
}

// start accelerator
if ((status = GoAccelerator_Start(accelerator)) != kOK)
{
    printf("Error: GoAccelerator_Start:%d\n", status);
    return;
}

printf ("GoAccelerator_Start completed\n");
if ((status = GoAccelerator_Attach(accelerator, sensor)) != kOK)
{
    printf("Error: GoAccelerator_Attach:%d\n", status);
    return;
}

// create connection to GoSensor object
if ((status = GoSensor_Connect(sensor)) != kOK)
{
    printf("Error: GoSensor_Connect:%d\n", status);
    return;
}
```

After, the SDK application can control an accelerated sensor in the same way as an unaccelerated sensor.

Sensor Device Files

This section describes the user-accessible device files stored on a sensor.

Live Files

Various "live" files stored on a sensor represent the sensor's active settings and transformations (represented together as "job" files), the active replay data (if any), and the sensor log.

By changing the live job file, you can change how the sensor behaves. For example, to make settings and transformations active, [write to](#) or [copy to](#) the `_live.job` file. You can also save active settings or transformations to a client computer, or to a file on the sensor, by [reading from](#) or [copying](#) these files, respectively.

 The live files are stored in volatile storage. Only user-created job files are stored in non-volatile storage.

The following table lists the live files:

Live Files

Name	Read/Write	Description
<code>_live.job</code>	Read/Write	The active job. This file contains a Configuration component containing the current settings. If Alignment Reference in the active job is set to Dynamic, it also contains a Transform component containing transformations. For more information on job files (live and user-created), accessing their components, and their structure, see <i>Job File Structure</i> on the next page.
<code>_live.cfg</code>	Read/Write	A standalone representation of the Configuration component contained in <code>_live.job</code> . Used primarily for backwards compatibility.
<code>_live.tfm</code>	Read/Write	If Alignment Reference of the active job is set to Dynamic: A copy of the Transform component in <code>_live.job</code> . Used primarily for backwards compatibility. If Alignment Reference of the active job is set to Fixed: The transformations that are used for <i>all</i> jobs whose Alignment Reference setting is set to Fixed.
<code>_live.log</code>	Read	A sensor log containing various messages. For more information on the log file, see <i>Log File</i> below.
<code>_live.rec</code>	Read/Write	The active replay simulation data.
<code>ExtendedId.xml</code>	Read	Sensor identification.

Log File

The log file contains log messages generated by the sensor. The root element is *Log*.

To access the log file, use the [Read File](#) command, passing "_live.log" to the command. The log file is read-only.

Log Child Elements

Element	Type	Description
@idStart	64s	Identifier of the first log.
@idEnd	64s	Identifier of the final log.
List of (Info Warning Error)	List	An ordered list of log entries. This list is empty if idEnd < idStart.

Log/Info | Log/Warning | Log/Error Elements

Element	Type	Description
@time	64u	Log time, in uptime (μ s).
@source	32u	The serial number of the sensor the log was produced by.
@id	32u	The Identifier, or index, of the log
@value	String	Log content; may contain printf-style format specifiers (e.g. %u).
List of (IntArg FloatArg Arg)	List	An ordered list of arguments: IntArg – Integer argument FloatArg – Floating-point argument Arg – Generic argument

The arguments are all sent as strings and should be applied in order to the format specifiers found in the content.

Job File Structure

The following sections describe the structure of job files.

Job files, which are stored in a sensor's internal storage, control system behavior when a sensor is running. Job files contain the settings and potentially the transformations associated with the job (if [Alignment Reference](#) is set to Dynamic).

There are two kinds of job files:

- A special job file called "_live.job." This job file contains the *active* settings and potentially the transformations associated with the job. It is stored in volatile storage.
- Other job files that are stored in non-volatile storage.

Job File Components

A job file contains components that can be loaded and saved as independent files. The following table lists the components of a job file:

Job File Components

Component	Path	Description
Configuration	config.xml	The job's configurations. This component is always present. For more

Component	Path	Description
		information, see <i>Configuration</i> below.
Transform	transform.xml	Transformation values. Present only if Alignment Reference is set to Dynamic. For more information, see <i>Transform</i> on page 340.

Elements in the components contain three types of values: settings, constraints, and properties. Settings are input values that can be edited. Constraints are read-only limits that define the valid values for settings. Properties are read-only values that provide supplemental information related to sensor setup.

When a job file is received from a sensor, it will contain settings, constraints, and properties. When a job file is sent to a sensor, any constraints or properties in the file will be ignored.

Changing the value of a setting can affect multiple constraints and properties. After you upload a job file, you can download the job file again to access the updated values of the constraints and properties.

Accessing Files and Components

Job file components can be accessed individually as XML files using path notation. For example, the configurations in a user-created job file called *productionRun01.job* can be read by passing "productionRun01.job/config.xml" to the [Read File](#) command. In the same way, the configurations in the active job could be read using "_live.job/config.xml".

 If [Alignment Reference](#) is set to Fixed, the active job file (_live.job) will not contain transformations. To access transformations in this case, you must access them via _live.tfm.

 The following sections correspond to the XML structure used in job file components.

Configuration

The Configuration component of a job file contains settings that control how a sensor behaves.

You can access the Configuration component of the active job as an XML file, either using path notation, via "_live.job/config.xml", or directly via "_live.cfg".

You can access the Configuration component in user-created job files in non-volatile storage, for example, "productionRun01.job/config.xml". You can only access configurations in user-created job files using path notation.

See the following sections for the elements contained in this component.

All sensors share a common job file structure and settings for all features are included in job files, regardless of the model.

 If a setting in a job file is not used by a sensor, the setting's *used* property is set to 0.

Configuration Child Elements

Element	Type	Description
@version	32u	Configuration version (101).

Element	Type	Description
@versionMinor	32u	Configuration minor version (9).
Setup	Section	For a description of the Setup elements, see <i>Setup</i> below.
Replay	Section	Contains settings related to recording filtering (see <i>Replay</i> on page 298).
Streams	Section	Read-only collection of available data streams (see <i>Streams/Stream (Read-only)</i> on page 299).
ToolOptions	Section	List of available tool types and their information. See <i>ToolOptions</i> on page 300 for details.
Tools	Collection	Collection of sections. Each section is an instance of a tool and is named by the type of the tool it describes. For more information, see the sections for each tool under <i>Tools</i> on page 302.
Tools.options	String (CSV)	Deprecated. Replaced by ToolOptions .
Outputs	Section	For a description of the Output elements, see <i>Output</i> on page 333.

Setup

The Setup element contains settings related to system and sensor setup.

Setup Child Elements

Element	Type	Description
TemperatureSafetyEnabled	Bool	Enables laser temperature safety control. Only applies to certain laser-based sensors.
TemperatureSafetyEnabled.used	Bool	Whether or not this property is used.
ScanMode	32s	The default scan mode.
ScanMode options	String (CSV)	List of available scan modes.
OcclusionReductionEnabled	Bool	Enables occlusion reduction.
OcclusionReductionEnabled.used	Bool	Whether or not property is used.
OcclusionReductionEnabled.value	Bool	Actual value used if not configurable.
OcclusionReductionAlg	32s	The Algorithm to use for occlusion reduction: 0 – Standard 1 – High Quality
OcclusionReductionAlg.used	Bool	Whether or not property is used
OcclusionReductionAlg.value	Bool	Actual value used if not configurable
UniformSpacingEnabled	Bool	Enables uniform spacing.
UniformSpacingEnabled.used	Bool	Whether or not property is used.
UniformSpacingEnabled.readonly	Bool	Whether or not property can be modified.
UniformSpacingEnabled.value	Bool	Actual value used if not configurable.
IntensityEnabled	Bool	Enables intensity data collection.
IntensityEnabled.used	Bool	Whether or not property is used.
IntensityEnabled.value	Bool	Actual value used if not configurable.
FlickerFreeModeEnabled	Bool	Enables flicker-free operation.

Element	Type	Description
FlickerFreeModeEnabled.used	Bool	Whether flicker-free operation can be used on this sensor.
ExternalInputZPulseEnabled	Bool	Enables the External Input based encoder Z Pulse feature.
ExternalInputZPulseIndex	32u	Input index to use for the input triggered z pulse feature.
ExternalInputZPulseEnabled.used	Bool	Whether the index can be set.
BackgroundSuppression	Section	See <i>BackgroundSuppression</i> below.
Filters	Section	See <i>Filters</i> below.
Trigger	Section	See <i>Trigger</i> on page 279.
Layout	Section	See <i>Layout</i> on page 281.
Alignment	Section	See <i>Alignment</i> on page 282.
Devices	Collection	A collection of two Device sections (with roles main and buddy). See <i>Devices / Device</i> on page 284.
SurfaceGeneration	Section	See <i>SurfaceGeneration</i> on page 291. Used by profile sensors.
SurfaceSections	Section	See <i>SurfaceSections</i> on page 292. Used by Gocator profile and snapshot sensors.
ProfileGeneration	Section	See <i>ProfileGeneration</i> on page 293.
PartDetection	Section	See <i>PartDetection</i> on page 294.
PartMatching	Section	See <i>PartMatching</i> on page 296. Used by Gocator profile and snapshot sensors.
Custom	Custom	Used by specialized sensors.

BackgroundSuppression

The BackgroundSuppression element contains settings related to background suppression.

BackgroundSuppression Child Elements

Element	Type	Description
Enabled	Bool	Enables background suppression.
FrameRatio	64f	Ratio of background frames to calibration frames

Filters

The Filters element contains settings related to post-processing profiles before they are output or used by measurement tools.

XSmoothing

XSmoothing Child Elements

Element	Type	Description
@used	Bool	Whether or not this field is used
Enabled	Bool	Enables filtering.
Window	64f	Window size (mm).
Window.min	64f	Minimum window size (mm).
Window.max	64f	Maximum window size (mm).

YSmoothing

YSmoothing Child Elements

Element	Type	Description
@used	Bool	Whether or not this field is used
Enabled	Bool	Enables filtering.
Window	64f	Window size (mm).
Window.min	64f	Minimum window size (mm).
Window.max	64f	Maximum window size (mm).

XGapFilling

XGapFilling Child Elements

Element	Type	Description
@used	Bool	Whether or not this field is used
Enabled	Bool	Enables filtering.
Window	64f	Window size (mm).
Window.min	64f	Minimum window size (mm).
Window.max	64f	Maximum window size (mm).

YGapFilling

YGapFilling Child Elements

Element	Type	Description
@used	Bool	Whether or not this field is used
Enabled	Bool	Enables filtering.
Window	64f	Window size (mm).
Window.min	64f	Minimum window size (mm).
Window.max	64f	Maximum window size (mm).

XMedian

XMedian Child Elements

Element	Type	Description
@used	Bool	Whether or not this field is used
Enabled	Bool	Enables filtering.
Window	64f	Window size (mm).
Window.min	64f	Minimum window size (mm).
Window.max	64f	Maximum window size (mm).

YMedian

YMedian Child Elements

Element	Type	Description
@used	Bool	Whether or not this field is used
Enabled	Bool	Enables filtering.
Window	64f	Window size (mm).
Window.min	64f	Minimum window size (mm).
Window.max	64f	Maximum window size (mm).

XDecimation

XDecimation Child Elements

Element	Type	Description
@used	Bool	Whether or not this field is used
Enabled	Bool	Enables filtering.
Window	64f	Window size (mm).
Window.min	64f	Minimum window size (mm).
Window.max	64f	Maximum window size (mm).

YDecimation

YDecimation Child Elements

Element	Type	Description
@used	Bool	Whether or not this field is used
Enabled	Bool	Enables filtering.
Window	64f	Window size (mm).
Window.min	64f	Minimum window size (mm).
Window.max	64f	Maximum window size (mm).

XSlope

 This filter is only available on displacement sensors.

XSlope Child Elements

Element	Type	Description
@used	Bool	Whether or not this field is used
Enabled	Bool	Enables filtering.
Window	64f	Window size (mm).
Window.min	64f	Minimum window size (mm).
Window.max	64f	Maximum window size (mm).

YSlope

 This filter is only available on displacement sensors.

YSlope Child Elements

Element	Type	Description
@used	Bool	Whether or not this field is used
Enabled	Bool	Enables filtering.
Window	64f	Window size (mm).
Window.min	64f	Minimum window size (mm).
Window.max	64f	Maximum window size (mm).

Trigger

The Trigger element contains settings related to trigger source, speed, and encoder resolution.

 Gocator 1300 series sensors are limited to sending data at 10 kHz over the analog output channel. Therefore, if you configure a sensor so that it runs at a speed higher than 10 kHz, and configure a measurement to be sent on the analog channel, you will get analog data drops. To achieve a 10 kHz analog output rate, you must enable and configure scheduled output.

Trigger Child Elements

Element	Type	Description
Source	32s	Trigger source: 0 – Time 1 – Encoder 2 – Digital Input 3 – Software
Source.options	32s (CSV)	List of available source options.
ExternalInputIndex	32s	Index of external input when Source (above) is set to 2 – Digital Input and connected to a Master. 0 – first digital input 1 – second digital input 2 – third digital input 3 – fourth digital input
ExternalInputIndex.options	32s (CSV)	List of available external input indices.
ExternalInputIndex.used	Bool	Whether the external input index used.
Units	32s	Sensor triggering units when source is not clock or encoder: 0 – Time 1 – Encoder
FrameRate	64f	Frame rate for time trigger (Hz).
FrameRate.min	64f	Minimum frame rate (Hz).

Element	Type	Description
FrameRate.max	64f	Maximum frame rate (Hz).
FrameRate.maxSource	32s	Source of maximum frame rate limit: 0 – Imager 1 – Surface generation
TracheidRate	64f	The frame rate of Tracheid data (Read Only)
TracheidRate.used	Bool	Whether the sensor has a Tracheid data rate.
FrameDataRate	64f	The frame rate of normal (range/profile/surface) data (Read Only)
FrameDataRate.used	Bool	Whether the sensor has a separate FrameDataRate
EncoderSpacing.min	64f	Minimum encoder spacing (mm).
EncoderSpacing.max	64f	Maximum encoder spacing (mm).
EncoderSpacing.minSource	32s	Source of minimum encoder spacing: 0 – Resolution 1 – Surface generation
EncoderSpacing.used	Bool	Whether or not this parameter is configurable.
EncoderTriggerMode	32s	Encoder triggering mode: 0 – Tracking backward 1 – Bidirectional 2 – Ignore backward
Delay	64f	Trigger delay (μ s or mm).
Delay.min	64f	Minimum trigger delay (μ s or mm).
Delay.max	64f	Maximum trigger delay (μ s or mm).
GateEnabled	Bool	Enables digital input gating.
GateEnabled.used	Bool	True if this parameter can be configured.
GateEnabled.value	Bool	Actual value if the parameter cannot be configured.
BurstEnabled	Bool	Enables burst triggering.
BurstEnabled.Used	Bool	Whether or not this parameter is configurable.
BurstCount	32u	Number of scans to take during burst triggering.
BurstCount.used	Bool	Whether or not this parameter is configurable.
BurstCount.max	32u	Maximum burst count.
ReversalDistanceAutoEnabled	Bool	Whether or not to use auto-calculated value.
ReversalDistanceAutoEnabled.used	Bool	Whether or not this parameter can be configured.
ReversalDistance	64f	Encoder reversal threshold (for jitter handling)
ReversalDistance.used	Bool	Whether or not this parameter is used.
ReversalDistance.value	64f	Actual value.
LaserSleepMode.used	Bool	Whether or not this feature can be configured.
LaserSleepMode/Enabled	Bool	Enables or disables the feature.

Element	Type	Description
LaserSleepMode/IdleTime	64u	Idle time before laser is turned off (μ s).
LaserSleepMode/WakupEncoderTravel	64u	Minimum amount of encoder movement before laser turns on (mm).

Layout

Layout Child Elements

Element	Type	Description
DataSource	32s	Data source of the layout output (read-only): 0 – Top 1 – Bottom 2 – Top left 3 – Top right 4 – Top Bottom 5 – Left Right
XSpacingCount	32u	Number of points along X when data is resampled.
YSpacingCount	32u	Number of points along Y when data is resampled.
TransformedDataRegion	Region3D	Transformed data region of the layout output.
Orientation	32s	Sensor orientation: 0 – Normal (single-sensor system) / Wide (dual-sensor system) 1 – Opposite 2 – Reverse 3 – Grid
Grid	Grid	Grid representation of the multi-sensor layout.
Orientation.options	32s (CSV)	List of available orientation options.
Orientation.value	32s	Actual value used if not configurable.
MultiplexBuddyEnabled	Bool	Enables multiplexing for buddies.
MultiplexSingleEnabled	Bool	Enables multiplexing for a single sensor configuration.
MultiplexSingleExposureDuration	64f	Exposure duration in μ s (currently rounded to integer when read by the sensor)
MultiplexSingleDelay	64f	Delay in μ s. (Currently gets rounded up when read by the sensor.)
MultiplexSinglePeriod	64f	Period in μ s. (Currently gets rounded up when read by the sensor.)
MultiplexSinglePeriod.min	64f	Minimum period in μ s.

Region3D Child Elements

Element	Type	Description
X	64f	X start (mm).
Y	64f	Y start (mm).
Z	64f	Z start (mm).
Width	64f	X extent (mm).

Element	Type	Description
Length	64f	Y extent (mm).
Height	64f	Z extent (mm).
ZAngle	64f	Z Angle start (degrees).
ZAngle.used	Bool	Whether or not this property is used.

Grid Elements

Element	Type	Description
ColumnCount	32u	Column count.
ColumnCount.value	32u	Column count value.

Alignment

The Alignment element contains settings related to alignment and encoder calibration.

Alignment Child Elements

Element	Type	Description
@used	Bool	Whether or not this field is used
InputTriggerEnabled	Bool	Enables digital input-triggered alignment operation.
InputTriggerEnabled.used	Bool	Whether or not this feature can be enabled. This feature is available only on some sensor models.
InputTriggerEnabled.value	Bool	Actual feature status.
Type	32s	Type of alignment operation: 0 – Stationary 1 – Moving
Type.options	32s (CSV)	List of available alignment types.
StationaryTarget	32s	Stationary alignment target: 0 – None 1 – Disk 2 – Bar 3 – Plate
StationaryTarget.options	32s (CSV)	List of available stationary alignment targets.
MovingTarget	32s	Moving alignment target: 1 – Disk 2 – Bar
MovingTarget.options	32s (CSV)	List of available moving alignment targets.
EncoderCalibrateEnabled	Bool	Enables encoder resolution calibration.
Disk	Section	See <i>Disk</i> on the next page.
Bar	Section	See <i>Bar</i> on the next page.
Plate	Section	See <i>Plate</i> on the next page.
Polygon	Section	See <i>Polygon</i> on the next page.

Disk

Disk Child Elements

Element	Type	Description
Diameter	64f	Disk diameter (mm).
Height	64f	Disk height (mm).

Bar

Bar Child Elements

Element	Type	Description
Width	64f	Bar width (mm).
Height	64f	Bar height (mm).
HoleCount	32u	Number of holes.
HoleCount.value	32u	Actual number of holes expected by system.
HoleCount.used	Bool	Whether the hole count will be used in the bar alignment procedure.
HoleDistance	64f	Distance between holes (mm).
HoleDistance.used	Bool	Whether the hole distance will be used in the bar alignment procedure.
HoleDiameter	64f	Diameter of holes (mm).
HoleDiameter.used	Bool	Whether the hole diameter will be used in the bar alignment procedure.
DegreesOfFreedom	32s	Degrees of freedom (DOF) to align: 42 – 3 DOF: x, z, y angle 58 – 4 DOF: x, y, z, y angle 59 – 5 DOF: x, y, z, y angle, z angle

Plate

Plate Child Elements

Element	Type	Description
Height	64f	Plate height (mm).
HoleCount	32u	Number of holes.
RefHoleDiameter	64f	Diameter of reference hole (mm).
SecHoleDiameter	64f	Diameter of secondary hole(s) (mm).

Polygon

Polygon Child Elements

Element	Type	Description
Corners	List	Contains a list of Corners (described below).
Corners.minCount	32s	Minimum number of corners.

Polygon/Corner

Corner Child Elements

Element	Type	Description
X	64f	X Position
Y	64f	Y Position
Devices	List of 32u	List of devices this corner is assigned to.
Devices.options	List of 32u	List of valid options for this field.

Devices / Device

Devices / Device Child Elements

Element	Type	Description
@index	32u	Ordered index of devices in device list.
@role	32s	Sensor role: 0 - Main 1 - Buddy
Layout	Layout	Multiplexing bank settings.
DataSource	32s	Data source of device output (read-only): 0 - Top 1 - Bottom 2 - Top Left 3 - Top Right
XSpacingCount	32u	Number of resampled points along X (read-only).
YSpacingCount	32u	Number of resampled points along Y (read-only).
ActiveArea	Region3D	Active area. (Contains min and max attributes for each element.)
TransformedDataRegion	Region3D	Active area after transformation (read-only).
FrontCamera	Window	Front camera window (read-only).
BackCamera	Window	Back camera window (read-only).
BackCamera.used	Bool	Whether or not this field is used.
PatternSequenceType	32s	The projector pattern sequence to display when a projector equipped device is running. The following types are possible: -1 - None 0 - Default 100 - Nine Lines 101 - Focus 102 - Standard Sequence
PatternSequenceType.options	32s	List of available pattern sequence types.
PatternSequenceType.used	Bool	Whether or not this field is used.
PatternSequenceIndex	32u	The index of the pattern sequence to display. Choose the pattern

Element	Type	Description
		that produces the best data.
		The indices represent Phase Pattern Sequences, followed by Stripe Pattern Sequences in reverse order. The lower indices are the higher frequency phase code patterns, and the higher indices are the lower frequency binary patterns.
		Index 1 [Phase Pattern Sequence Image 5]: Highest frequency sinusoid.
		Index 2 [Phase Pattern Sequence Image 4]
		[...]
		Index 5 [Phase Pattern Sequence Image 1]: Lowest frequency sinusoid.
		Index 6 [Stripe Pattern Sequence Image 7]: Highest bar count.
		Index 7 [Stripe Pattern Sequence Image 6]
		[...]
		Index 12 [Stripe Pattern Sequence Image 1]: Lowest bar count)
		Index 13 [Reference Image 1]
PatternSequenceIndex.min	32u	The minimum index (inclusive)
PatternSequenceIndex.max	32u	The maximum index (inclusive)
PatternSequenceIndex.used	Bool	Whether or not the pattern sequence index should be displayed
PatternSequenceIndex	32u	The index of the pattern sequence to display.
PatternSequenceIndex.min	32u	The minimum index (inclusive).
PatternSequenceIndex.max	32u	The maximum index (inclusive).
PatternSequenceIndex.used	Bool	Whether or not the pattern sequence index should be displayed.
PatternSequenceCount	32u	Number of frames in the active sequence (read-only).
ExposureMode	32s	Exposure mode: 0 – Single exposure 2 – Dynamic exposure
ExposureMode.options	32s (CSV)	List of available exposure modes.
Exposure	64f	Single exposure (μ s).
Exposure.min	64f	Minimum exposure (μ s).
Exposure.max	64f	Maximum exposure (μ s).
Exposure.used	Bool	Whether or not this field is used.
DynamicExposureMin	64f	Dynamic exposure range minimum (μ s).
DynamicExposureMax	64f	Dynamic exposure range maximum (μ s).
ExposureSteps	64f (CSV)	Mutiple exposure list (μ s).
ExposureSteps.countMin	32u	Minimum number of exposure steps.

Element	Type	Description
ExposureSteps.countMax	32u	Maximum number of exposure steps.
IntensitySource	32s	Intensity source: 0 – Both cameras 1 – Front camera 2 – Back camera
IntensitySource.options	32s (CSV)	List of available intensity sources.
IntensityMode	32s	Intensity Mode: 0 – Auto 1 – Preserve
IntensityMode.used	Bool	Whether intensity mode is used
ZSubsampling	32u	Subsampling factor in Z.
ZSubsampling.options	32u (CSV)	List of available subsampling factors in Z.
SpacingInterval	64f	Uniform spacing interval (mm).
SpacingInterval.min	64f	Minimum spacing interval (mm).
SpacingInterval.max	64f	Maximum spacing interval (mm).
SpacingInterval.used	Bool	Whether or not field is used.
SpacingInterval value	64f	Actual value used.
SpacingIntervalType	32s	Spacing interval type: 0 – Maximum resolution 1 – Balanced 2 – Maximum speed 3 – Custom
SpacingIntervalType.used	Bool	Whether or not this field is used.
Tracking	Section	See <i>Tracking Child Elements</i> on the next page.
Material	Section	See <i>Material Child Elements</i> on page 288.
Tracheid	Section	See <i>Tracheid Child Elements</i> on page 291.
IndependentExposures	Section	See <i>IndependentExposures Child Elements</i> on page 290
Custom	Custom	Used by specialized sensors.

Region3D Child Elements

Element	Type	Description
X	64f	X start (mm).
Y	64f	Y start (mm).
Z	64f	Z start (mm).
Width	64f	X extent (mm).
Length	64f	Y extent (mm).

Element	Type	Description
Height	64f	Z extent (mm).
ZAngle	64f	Z Angle start (degrees).
ZAngle.used	Bool	Whether or not this property is used.

Window Child Elements

Element	Type	Description
X	32u	X start (pixels).
Y	32u	Y start (pixels).
Width	32u	X extent (pixels).
Height	32u	Y extent (pixels).

Layout Child Elements

Element	Type	Description
Grid	Grid	Layout grid information.
MultiplexingBank	32u	Multiplexing bank ID
MultiplexingBank.used	32u	Whether or not this field can be specified
MultiplexingBank.value	32u	Actual value used by system

Grid Child Elements

Element	Type	Description
@used	Bool	Whether or not this section is used.
Row	32s	Device row position in grid layout.
Row.value	32s	Value in use by the sensor, useful for determining value when used is false.
Column	32s	Device column position in grid layout.
Column.value	32s	Value in use by the sensor, useful for determining value when used is false.
Direction	32s	Sensor orientation direction.
Direction.value	32s	Value in use by the sensor, useful for determining value when used is false.

 Tracking is only available on Gocator 2300 and 2400 series sensors.

Tracking Child Elements

Element	Type	Description
Enabled	Bool	Enables tracking.
Enabled.used	Bool	Whether or not this field is used.
SearchThreshold	64f	Percentage of spots that must be found to remain in track.
Height	64f	Tracking window height (mm).
Height.min	64f	Minimum tracking window height (mm).
Height.max	64f	Maximum tracking window height (mm).

Material Child Elements

Element	Type	Description
Type	32s	Type of Material settings to use. 0 – Custom 1 – Diffuse 3 – Reflective
Type.used	Bool	Determines if the setting's value is currently used.
Type.value	32s	Value in use by the sensor, useful for determining value when used is false.
Type.options	32u (CSV)	List of available material types.
SpotThreshold	32s	Spot detection threshold.
SpotThreshold.min	32s	The minimum spot detection threshold possible.
SpotThreshold.max	32s	The maximum spot detection threshold possible.
SpotThreshold.used	Bool	Determines if the setting's value is currently used.
SpotThreshold.value	32s	Value in use by the sensor, useful for determining value when used is false.
SpotThreshold.readonly	Bool	Whether or not property can be modified. If set, the value should be considered read-only by the client. Only has meaning if "used" is also set.
SpotWidthMax	32s	Spot detection maximum width.
SpotWidthMax.used	Bool	Determines if the setting's value is currently used.
SpotWidthMax.value	32s	Value in use by the sensor, useful for determining value when used is false.
SpotWidthMax.min	32s	Minimum allowed spot detection maximum value.
SpotWidthMax.max	32s	Maximum allowed spot detection maximum value.
SpotSelectionType	32s	Spot selection type 0 – Best. Picks the strongest spot in a given column. 1 – Top. Picks the spot which is most Top/Left on the imager 2 – Bottom. Picks the spot which is most Bottom/Right on the imager 3 – None. All spots are available. This option may not be available in some configurations. 4 – Continuity. Picks the most continuous spot.
SpotSelectionType.used	Bool	Determines if the setting's value is currently used.
SpotSelectionType.value	32s	Value in use by the sensor, useful for determining value when used is false.
SpotSelectionType.options	32s (CSV)	List of available spot selection types.
CameraGainAnalog	64f	Analog camera gain factor.

Element	Type	Description
CameraGainAnalog.used	Bool	Determines if the setting's value is currently used.
CameraGainAnalog.value	64f	Value in use by the sensor, useful for determining value when used is false.
CameraGainAnalog.min	64f	Minimum value.
CameraGainAnalog.max	64f	Maximum value.
CameraGainDigital	64f	Digital camera gain factor.
CameraGainDigital.used	Bool	Determines if the setting's value is currently used.
CameraGainDigital.value	64f	Value in use by the sensor, useful for determining value when used is false.
CameraGainDigital.min	64f	Minimum value.
CameraGainDigital.max	64f	Maximum value.
DynamicSensitivity	64f	Dynamic exposure control sensitivity factor. This can be used to scale the control setpoint.
DynamicSensitivity.used	Bool	Determines if the setting's value is currently used.
DynamicSensitivity.value	64f	Value in use by the sensor, useful for determining value when used is false.
DynamicSensitivity.min	64f	Minimum value.
DynamicSensitivity.max	64f	Maximum value.
DynamicThreshold	32s	Dynamic exposure control threshold. If the detected number of spots is fewer than this number, the exposure will be increased.
DynamicThreshold.used	Bool	Determines if the setting's value is currently used.
DynamicThreshold.value	32s	Value in use by the sensor, useful for determining value when used is false.
DynamicThreshold.min	32s	Minimum value.
DynamicThreshold.max	32s	Maximum value.
SensitivityCompensationEnabled	Bool	Sensitivity compensation toggle. Used in determining analog and digital gain, along with exposure scale.
SensitivityCompensationEnabled.used	Bool	Determines if the setting's value is currently used.
SensitivityCompensationEnabled.value	Bool	Value in use by the sensor, useful for determining value when used is false.
GammaType	32s	Gamma type.
GammaType used	Bool	Determines if the setting's value is currently used.
GammaType value	32s	Value in use by the sensor. Useful for determining value when used is false.
SpotContinuitySorting	Section	See <i>SpotContinuitySorting Child Elements</i> on the next page.
SurfaceEncoding	32s	Surface encoding type: 0 – Standard

Element	Type	Description
		1 - Interreflection (advanced use only)
SurfaceEncoding.used	Bool	Determines if the setting's value is currently used.
SurfaceEncoding.value	Bool	Value in use by the sensor, useful for determining value when used is false.
SurfaceEncoding.readonly	Bool	Whether or not property can be modified. If set, the value should be considered read-only by the client. Only has meaning if "used" is also set.
SurfacePhaseFilter	32s	Surface phase filter (correction type) 0 - None 1 - Reflective 2 - Translucent
SurfacePhaseFilter.used	Bool	Determines if the setting's value is currently used.
SurfacePhaseFilter.value	Bool	Value in use by the sensor, useful for determining value when used is false.
ContrastThreshold	32s	Contrast detection threshold.
ContrastThreshold.min	32s	The minimum contrast detection threshold possible.
ContrastThreshold.max	32s	The maximum contrast detection threshold possible.
ContrastThreshold.used	Bool	Determines if the setting's value is currently used.
ContrastThreshold.value	32s	Value in use by the sensor, useful for determining value when used is false.
ContrastThreshold.readonly	Bool	Whether or not property can be modified. If set, the value should be considered read-only by the client. Only has meaning if "used" is also set.

SpotContinuitySorting Child Elements

Element	Type	Description
MinimumSegmentSize	32u	Smallest continuous segment considered in continuity sorting.
SearchWindow/X	32u	X component of continuity sorting search window size.
SearchWindow/Y	32u	Y component of continuity sorting search window size.

 IndependentExposures settings are only supported by 3x00 series sensors.

IndependentExposures Child Elements

Element	Type	Description
@used	Bool	Whether this field is used
Enabled	Bool	Whether to allow using separate exposure values for each camera
FrontCameraExposure	64f	The exposure value to use for the front camera
FrontCameraExposure.min	64f	The minimum exposure value possible for front camera

Element	Type	Description
FrontCameraExposure.max	64f	The maximum exposure value possible for back camera
BackCameraExposure	64f	The exposure value to use for the front camera
BackCameraExposure.min	64f	The minimum exposure value possible for front camera
BackCameraExposure.max	64f	The maximum exposure value possible for back camera

 Tracheid settings are only supported by Gocator 200 series multi-point sensors.

Tracheid Child Elements

Element	Type	Description
@used	Bool	Whether this field is used
TracheidExposureEnabled	Bool	Whether to use a unique exposure for tracheid capture
TracheidExposure	64f	The exposure value to use for tracheid measurements
TracheidExposure.min	64f	The minimum exposure value possible tracheid measurements
TracheidExposure.max	64f	The maximum exposure value possible for tracheid measurements
Camera0Threshold	32u	The tracheid threshold for camera 0
Camera1Threshold	32u	The tracheid threshold for camera 1

SurfaceGeneration

The SurfaceGeneration element contains settings related to surface generation.

This element is used by laser profile sensors.

SurfaceGeneration Child Elements

Element	Type	Description
Type	32s	Surface generation type: 0 - Continuous 1 - Fixed length 2 - Variable length 3 - Rotational
Type.options	32s (CSV)	List of available generation types
Type.value	32s	Value in use by the sensor
FixedLength	Section	See <i>FixedLength</i> on the next page.
VariableLength	Section	See <i>VariableLength</i> on the next page.
Rotational	Section	See <i>Rotational</i> on the next page.

FixedLength

FixedLength Child Elements

Element	Type	Description
StartTrigger	32s	Start trigger condition: 0 – Sequential 1 – Digital input 2 – Software triggered
ExternalInputIndex	32s	Index of external input when Source (above) is set to 1 – Digital Input and connected to a Master. 0 – first digital input 1 – second digital input 2 – third digital input 3 – fourth digital input
ExternalInputIndex.options	32s (CSV)	List of available external input indices.
ExternalInputIndex.used	Bool	Is the external input index in use.
Length	64f	Surface length (mm).
Length.min	64f	Minimum surface length (mm).
Length.max	64f	Maximum surface length (mm).

VariableLength

VariableLength Child Elements

Element	Type	Description
MaxLength	64f	Maximum surface length (mm).
MaxLength.min	64f	Minimum value for maximum surface length (mm).
MaxLength.max	64f	Maximum value for maximum surface length (mm).

Rotational

Rotational Child Elements

Element	Type	Description
Circumference	64f	Circumference (mm).
Circumference.min	64f	Minimum circumference (mm).
Circumference.max	64f	Maximum circumference (mm).

SurfaceSections

SurfaceSections Child Elements

Element	Type	Description
@used	Bool	Whether surface sectioning is enabled.
@xMin	64f	The minimum valid X value to be used for section definition.
@xMax	64f	The maximum valid X value to be used for section definition.

Element	Type	Description
@yMin	64f	The minimum valid Y value to be used for section definition.
@yMax	64f	The maximum valid Y value to be used for section definition.
Section	Collection	A series of Section elements.

Section Child Elements

Element	Type	Description
@id	32s	The ID assigned to the surface section.
@name	String	The name associated with the surface section.
StartPoint	Point64f	The beginning point of the surface section.
EndPoint	Point64f	The end point of the surface section.
CustomSpacingIntervalEnabled	Bool	Indicates whether a user specified custom spacing interval is to be used for the resulting section.
SpacingInterval	64f	The user specified spacing interval.
SpacingInterval.min	64f	The spacing interval limit minimum.
SpacingInterval.max	64f	The spacing interval limit maximum.
SpacingInterval.value	64f	The current spacing interval used by the system.

ProfileGeneration

The ProfileGeneration element contains settings related to profile generation.

ProfileGeneration Child Elements

Element	Type	Description
Type	32s	Profile generation type: 0 – Continuous 1 – Fixed length 2 – Variable length 3 – Rotational
Type.options	32s (CSV)	List of available generation types
Type.value	32s	Value in use by the sensor
FixedLength	Section	See <i>FixedLength</i> below.
VariableLength	Section	See <i>VariableLength</i> on the next page.
Rotational	Section	See <i>Rotational</i> on the next page.

FixedLength

FixedLength Child Elements

Element	Type	Description
StartTrigger	32s	Start trigger condition: 0 – Sequential 1 – Digital input

Element	Type	Description
		2 – Software triggered
ExternalInputIndex	32s	Index of external input when Source (above) is set to 1 – Digital Input and connected to a Master. 0 – first digital input 1 – second digital input 2 – third digital input 3 – fourth digital input
ExternalInputIndex.options	32s (CSV)	List of available external input indices.
ExternalInputIndex.used	Bool	Is the external input index in use.
Length	64f	Profile length (mm).
Length.min	64f	Minimum profile length (mm).
Length.max	64f	Maximum profile length (mm).

VariableLength

VariableLength Child Elements

Element	Type	Description
MaxLength	64f	Maximum surface length (mm).
MaxLength.min	64f	Minimum value for maximum profile length (mm).
MaxLength.max	64f	Maximum value for maximum profile length (mm).

Rotational

Rotational Child Elements

Element	Type	Description
Circumference	64f	Circumference (mm).
Circumference.min	64f	Minimum circumference (mm).
Circumference.max	64f	Maximum circumference (mm).

PartDetection

PartDetection Child Elements

Element	Type	Description
Enabled	Bool	Enables part detection.
Enabled.used	Bool	Whether or not this field is used.
Enabled value	Bool	Actual value used if not configurable.
MinArea	64f	Minimum area (mm ²).
MinArea.min	64f	Minimum value of minimum area.
MinArea.max	64f	Maximum value of minimum area.
MinArea.used	Bool	Whether or not this field is used.

Element	Type	Description
GapWidth	64f	Gap width (mm).
GapWidth.min	64f	Minimum gap width (mm).
GapWidth.max	64f	Maximum gap width (mm).
GapWidth.used	Bool	Whether or not this field is used.
GapLength	64f	Gap length (mm).
GapLength.min	64f	Minimum gap length (mm).
GapLength.max	64f	Maximum gap length (mm).
GapLength.used	Bool	Whether or not this field is used.
PaddingWidth	64f	Padding width (mm).
PaddingWidth.min	64f	Minimum padding width (mm).
PaddingWidth.max	64f	Maximum padding width (mm).
PaddingWidth.used	Bool	Whether or not this field is used.
PaddingLength	64f	Padding length (mm).
PaddingLength.min	64f	Minimum padding length (mm).
PaddingLength.max	64f	Maximum padding length (mm).
PaddingLength.used	Bool	Whether or not this field is used.
MinLength	64f	Minimum length (mm).
MinLength.min	64f	Minimum value of minimum length (mm).
MinLength.max	64f	Maximum value of minimum length (mm).
MinLength.used	Bool	Whether or not this field is used.
MaxLength	64f	Maximum length (mm).
MaxLength.min	64f	Minimum value of maximum length (mm).
MaxLength.max	64f	Maximum value of maximum length (mm).
MaxLength.used	Bool	Whether or not this field is used.
Threshold	64f	Height threshold (mm).
Threshold.min	64f	Minimum height threshold (mm).
Threshold.max	64f	Maximum height threshold (mm).
ThresholdDirection	32u	Threshold direction: 0 – Above 1 – Below
FrameOfReference	32s	Part frame of reference: 0 – Sensor 1 – Scan 2 – Part
FrameOfReference.used	Bool	Whether or not this field is used.
FrameOfReference.value	32s	Actual value.

Element	Type	Description
IncludeSinglePointsEnabled	Bool	Enables preservation of single data points in Top+Bottom layout
IncludeSinglePointsEnabled.used	Bool	Whether or nto this field is available to be modified
EdgeFiltering	Section	See <i>EdgeFiltering</i> below. (Not used by G1 sensors.)

EdgeFiltering

EdgeFiltering Child Elements

Element	Type	Description
@used	Bool	Whether or not this section is used.
Enabled	Bool	Enables edge filtering.
PreserveInteriorEnabled	Bool	Enables preservation of interior.
ElementWidth	64f	Element width (mm).
ElementWidth.min	64f	Minimum element width (mm).
ElementWidth.max	64f	Maximum element width (mm).
ElementLength	64f	Element length (mm).
ElementLength.min	64f	Minimum element length (mm).
ElementLength.max	64f	Maximum element length (mm).

PartMatching

The PartMatching element contains settings related to part matching. This element is used by Gocator profile and snapshot sensors.

PartMatching Child Elements

Element	Type	Description
Enabled	Bool	Enables part matching.
Enabled.used	Bool	Whether or not this field is used.
MatchAlgo	32s	Match algorithm. 0 – Edge points 1 – Bounding Box 2 – Ellipse
Edge	Section	See <i>Edge</i> below.
BoundingBox	Section	See <i>BoundingBox</i> on the next page.
Ellipse	Section	See <i>Ellipse</i> on the next page.

Edge

Edge Child Elements

Element	Type	Description
ModelName	String	Name of the part model to use. Does not include the .mdl extension.
Acceptance/Quality/Min	64f	Minimum quality value for a match.

BoundingBox

BoundingBox Child Elements

Element	Type	Description
ZAngle	64f	Z rotation to apply to bounding box (degrees).
AsymmetryDetectionType	32s	Determine whether to use asymmetry detection and, if enabled, which dimension is the basis of detection. The possible values are: 0 – None 1 – Length 2 – Width
Acceptance/Width/Min	64f	Minimum width (mm).
Acceptance/Width/Max	64f	Maximum width (mm).
Acceptance/Width/Tolerance	64f	Width acceptance tolerance value
Acceptance/Width/Tolerance.deprecated	Bool	Whether this tolerance field is deprecated
Acceptance/Length/Min	64f	Minimum length (mm).
Acceptance/Length/Max	64f	Maximum length (mm).
Acceptance/Length/Tolerance	64f	Length acceptance tolerance value
Acceptance/Length/Tolerance.deprecated	Bool	Whether this tolerance field is deprecated
X	64f	X value
X.deprecated	Bool	Whether this X field is deprecated
Y	64f	Y value
Y.deprecated	Bool	Whether this Y field is deprecated
Width	64f	Width value
Width.deprecated	Bool	Whether this width field is deprecated
Length	64f	Length value
Length.deprecated	Bool	Whether this length field is deprecated

Ellipse

Ellipse Child Elements

Element	Type	Description
ZAngle	64f	Z rotation to apply to ellipse (degrees).
AsymmetryDetectionType	32s	Determine whether to use asymmetry detection and, if enabled, which dimension is the basis of detection. The possible values are: 0 – None 1 – Major 2 – Minor
Acceptance/Major/Min	64f	Minimum major length (mm).

Element	Type	Description
Acceptance/Major/Max	64f	Maximum major length (mm).
Acceptance/Major/Tolerance	64f	Major acceptance tolerance value
Acceptance/Major/Tolerance.deprecated	Bool	Whether this tolerance field is deprecated
Acceptance/Minor/Min	64f	Minimum minor length (mm).
Acceptance/Minor/Max	64f	Maximum minor length (mm).
Acceptance/Minor/Tolerance	64f	Minor acceptance tolerance value
Acceptance/Minor/Tolerance.deprecated	Bool	Whether this tolerance field is deprecated
X	64f	X value
X.deprecated	Bool	Whether this X field is deprecated
Y	64f	Y value
Y.deprecated	Bool	Whether this Y field is deprecated
Width	64f	Width value
Width.deprecated	Bool	Whether this width field is deprecated
Length	64f	Length value
Length.deprecated	Bool	Whether this length field is deprecated

Replay

Contains settings related to recording filtering.

RecordingFiltering

RecordingFiltering Child Elements

Element	Type	Description
ConditionCombineType	32s	0 – Any: If any enabled condition is satisfied, the current frame is recorded. 1 – All: All enabled conditions must be satisfied for the current frame to be recorded.
Conditions	Collection	A collection of AnyMeasurement , AnyData , or Measurement conditions.

Conditions/AnyMeasurement

Conditions/AnyMeasurement Elements

Element	Type	Description
Enabled	Bool	Indicates whether the condition is enabled.
Result	32s	The measurement decision criteria to be included in the filter. Possible values are: 0 – Pass 1 – Fail 2 – Valid 3 – Invalid

Conditions/AnyData

Conditions/AnyData Elements

Element	Type	Description
Enabled	Bool	Indicates whether the condition is enabled.
RangeCountCase	32s	The case under which to record data: 0 – Range count at or above threshold of valid data points. 1 – Range count below threshold.
RangeCountThreshold	32u	The threshold for the number of range points that are valid.

Conditions/Measurement

Conditions/Measurement Elements

Element	Type	Description
Enabled	Bool	Indicates whether the condition is enabled.
Result	32s	The measurement decision criteria for the selected ID to be included in the filter. Possible values are: 0 – Pass 1 – Fail 2 – Valid 3 – Invalid
Ids	32s	The ID of the measurement to filter.

Streams/Stream (Read-only)

Streams/Stream Child Elements

Element	Type	Description
Step	32s	The data step of the stream being described. Possible values are: 1 – Video 2 – Range 3 – Surface 4 – Section
Id	32u	The stream ID.
CadenceId	32u	Represents a stage in the data processing pipeline. The greater the number, the farther removed from the initial acquisition stage. One of the following: 0 – Primary 1 – Auxiliary 10 – Diagnostic
DataType	32s	The stream data type 0 – None 4 – Uniform Profile

Element	Type	Description
		16 – Uniform Surface
ColorEncoding	32s	The color encoding type. Only appears for Video stream steps (1). 0 – None 1 – Bayer BGGR 2 – Bayer GBRG 3 – Bayer RGGB 4 – Bayer GRBG
IntensityEnabled	Bool	Whether the stream includes intensity data
Sources	Collection	A collection of Source elements as described below.

Source Child Elements

Element	Type	Description
Id	32s	The ID of the data source. Possible values are: 0 – Top 1 – Bottom 2 – Top Left 3 – Top Right 4 – Top Bottom 5 – Left Right
Capability	32s	The capability of the data stream source. Possible values are: 0 – Full 1 – Diagnostic only 2 – Virtual
Region	Region3d	The region of the given stream source.
AdditionalRegions	Collection	Collection of additional regions (for example, for the second camera).
AdditionalRegions/Region	Region3d	Additional regions.

ToolOptions

The ToolOptions element contains a list of available tool types, their measurements, and settings for related information.

ToolOptions Child Elements

Element	Type	Description
<Tool Names>	Collection	A collection of tool name elements. An element for each tool type is present.

Tool Name Child Elements

Element	Type	Description
@displayName	String	Display name of the tool.
@isCustom	Bool	Reserved for future use.

Element	Type	Description
@format	32s	Format type of the tool: 0 – Standard built-in tool 1 – GDK user-defined tool 2 – Internal GDK tool
MeasurementOptions	Collection	See <i>MeasurementOptions</i> below
FeatureOptions	Collection	See <i>FeatureOptions</i> below.
StreamOptions	Collection	See <i>StreamOptions</i> on the next page.

MeasurementOptions

MeasurementOptions Child Elements

Element	Type	Description
<Measurement Names>	Collection	A collection of measurement name elements. An element for each measurement is present.

<Measurement Name> Child Elements

Element	Type	Description
@displayName	String	Display name of the tool.
@minCount	32u	Minimum number of instances in a tool.
@maxCount	32u	Maximum number of instances in a tool.

FeatureOptions

FeatureOptions Child Elements

Element	Type	Description
<Feature Names>	Collection	A collection of feature name elements. An element for each measurement is present.

<Feature Name> Child Elements

Element	Type	Description
@displayName	String	Display name of the feature.
@minCount	32u	Minimum number of instances in a tool.
@maxCount	32u	Maximum number of instances in a tool.
@dataType	String	The data type of the feature. One of: – PointFeature – LineFeature – CircleFeature – PlaneFeature

StreamOptions

StreamOptions Child Elements

Element	Type	Description
@step	32s	The data step of the stream being described. Possible values are: 1 - Video 2 - Range 3 - Surface 4 - Section
@ids	CSV	A list representing the available IDs associated with the given step.

Tools

The Tools element contains measurement tools. The following sections describe each tool and its available measurements.

Tools Child Elements

Element	Type	Description
@options	String (CSV)	A list of the tools available in the currently selected scan mode.
<ToolType>	Section	An element for each added tool.

Profile Types

The following types are used by various measurement tools.

ProfileFeature

An element of type ProfileFeature defines the settings for detecting a feature within an area of interest.

ProfileFeature Child Elements

Element	Type	Description
Type	32s	Determine how the feature is detected within the area: 0 - Max Z 1 - Min Z 2 - Max X 3 - Min X 4 - Corner 5 - Average 6 - Rising Edge 7 - Falling Edge 8 - Any Edge 9 - Top Corner 10 - Bottom Corner 11 - Left Corner 12 - Right Corner

Element	Type	Description
		13 – Median
RegionEnabled	Bool	Indicates whether feature detection applies to the defined Region or to the entire active area.
Region	ProfileRegion2D	Element for feature detection area.

ProfileLine

An element of type ProfileLine defines measurement areas used to calculate a line.

ProfileLine Child Elements

Element	Type	Description
RegionCount	32s	Count of the regions.
Regions	(Collection)	The regions used to calculate a line. Contains one or two Region elements of type ProfileRegion2D , with RegionEnabled fields for each.

ProfileRegion2d

An element of type ProfileRegion2d defines a rectangular area of interest.

ProfileRegion2d Child Elements

Element	Type	Description
X	64f	Setting for profile region X position (mm).
Z	64f	Setting for profile region Z position (mm).
Width	64f	Setting for profile region width (mm).
Height	64f	Setting for profile region height (mm).

Geometric Feature Types

The Geometric Feature type is used by various measurement tools.

Feature Child Elements

Element	Type	Description
@id	32s	The identifier of the geometric feature. -1 if unassigned.
@dataType	String	The data type of the feature. One of: – PointFeature – LineFeature
@type	String	Type name of feature.
Name	String	The display name of the feature.
Enabled	Bool	Whether the given feature output is enabled.
Parameters	Collection	Collection of GdkParam elements.

Parameter Types

The following types are used by internal and custom (user-created) GDK-based tools.

GDK Parameter Child Elements

Element	Type	Description
@label	String	Parameter label.
@type	String	Type of parameter. It is one of the following (see tables below for elements found in each type): <ul style="list-style-type: none">- Bool- Int- Float- ProfileRegion- SurfaceRegion2d- SurfaceRegion3d- GeometricFeature
@options	Variant (CSV)	Options available for this parameter.
@optionNames	String (CSV)	Names

GDK Parameter Bool Type

Element	Type	Description
	Bool	Boolean value of parameter.

GDK Parameter Int Type

Element	Type	Description
	32s	Integer value of parameter of integer type.

GDK Parameter Float Type

Element	Type	Description
	64f	Floating point value of parameter.

GDK Parameter String Type

Element	Type	Description
	String	String value of parameter.

GDK Parameter Profile Region Type

Element	Type	Description
X	64f	X value of region.
Z	64f	Z value of region.
Width	64f	Width value of region.
Height	64f	Height value of region.

GDK Parameter Surface Region 2D Type

Element	Type	Description
X	64f	X value of region.
X	64f	X value of region.

Element	Type	Description
Y	64f	Y value of region.
Width	64f	Width value of region.
Length	64f	Length value of region.

GDK Parameter Surface Region 3D Type

Element	Type	Description
X	64f	X value of region.
Y	64f	Y value of region.
Z	64f	Z value of region.
Width	64f	Width value of region.
Length	64f	Length value of region.
Height	64f	Height value of region.
ZAngle	64f	ZAngle value of region.

GDK Parameter Geometric Feature Type

Element	Type	Description
	32s	Geometric feature Id for parameter.

RangePosition

A RangePosition element defines settings for a range position tool and its measurement.

RangePosition Child Elements

Element	Type	Description
@isCustom	Bool	Reserved for future use.
@format	32s	Format type of the tool: 0 – Standard built-in tool 1 – GDK user-defined tool 2 – Internal GDK tool
@id	32s	The tool's ID.
Name	String	Tool name.
Features	Collection	Not used.
Source	32s	Range source.
Anchor\Z	String (CSV)	The Z measurements (IDs) used for anchoring.
Anchor\Z.options	String (CSV)	The Z measurements (IDs) available for anchoring.
StreamOptions	Collection	Not used.
Stream\Step	32s	Not used.
Stream\ld	32u	Not used.
Measurements\Z	Position tool measurement	Z measurement. Determines the Z axis position of the laser range.

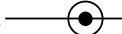
Position Z 

Position Tool Measurement

Element	Type	Description
@id	32s	Measurement ID. Optional (measurement disabled if not set).
Name	String	Measurement name.
Enabled	Boolean	Measurement enable state: 0 – Disable 1 – Enable
HoldEnabled	Boolean	Output hold enable state: 0 – Disable 1 – Enable
SmoothingEnabled	Boolean	Smoothing enable state: 0 – Disable 1 – Enable
PreserveInvalidsEnabled	Boolean	Preserve invalid measurements enable state 0 – Disable 1 – Enable
SmoothingWindow	32u	Smoothing window.
Scale	64f	Output scaling factor.
Offset	64f	Output offset factor.
DecisionMin	64f	Minimum decision threshold.
DecisionMax	64f	Maximum decision threshold.

@displayName String Display name of the tool.

@isCustom Bool Reserved for future use.

@format 32s Format type of the tool:
0 – Standard built-in tool
1 – GDK user-defined tool
2 – Internal GDK tool

RangeThickness

A RangeThickness element defines settings for a range thickness tool and its measurement.

RangeThickness Child Elements

Element	Type	Description
@isCustom	Bool	Reserved for future use.
@format	32s	Format type of the tool: 0 – Standard built-in tool

Element	Type	Description
		1 - GDK user-defined tool 2 - Internal GDK tool
@id	32s	The tool's ID.
Name	String	Tool name.
Features	Collection	Not used.
Source	32s	Range source.
Anchor\Z	String (CSV)	The Z measurements (IDs) used for anchoring.
Anchor\Z.options	String (CSV)	The Z measurements (IDs) available for anchoring.
StreamOptions	Collection	Not used.
Stream\Step	32s	Not used
Stream\ld	32u	Not used.
Absolute	Boolean	Setting for selecting absolute or signed result: 0 - Signed 1 - Absolute
Measurements\Thickness	Thickness tool measurement	Thickness measurement.

Thickness Tool Measurement

Element	Type	Description
@id	32s	Measurement ID. Optional (measurement disabled if not set).
Name	String	Measurement name.
Enabled	Boolean	Measurement enable state: 0 - Disable 1 - Enable
HoldEnabled	Boolean	Output hold enable state: 0 - Disable 1 - Enable
SmoothingEnabled	Boolean	Smoothing enable state: 0 - Disable 1 - Enable
PreserveInvalidsEnabled	Boolean	Preserve invalid measurements enable state 0 - Disable 1 - Enable
SmoothingWindow	32u	Smoothing window.
Scale	64f	Output scaling factor.
Offset	64f	Output offset factor.

Element	Type	Description
DecisionMin	64f	Minimum decision threshold.
DecisionMax	64f	Maximum decision threshold.

ProfileArea

A ProfileArea element defines settings for a profile area tool and one or more of its measurements.

ProfileArea Child Elements

Element	Type	Description
@isCustom	Bool	Reserved for future use.
@format	32s	Format type of the tool: 0 – Standard built-in tool 1 – GDK user-defined tool 2 – Internal GDK tool
@id	32s	The tool's ID.
Name	String	Tool name.
Features	Collection	Collection of geometric feature outputs available in the tool. See <i>ProfileArea</i> above.
Source	32s	Profile source.
Anchor\X	String (CSV)	The X measurements (IDs) used for anchoring.
Anchor\X.options	String (CSV)	The X measurements (IDs) available for anchoring.
Anchor\Z	String (CSV)	The Z measurements (IDs) used for anchoring.
Anchor\Z.options	String (CSV)	The Z measurements (IDs) available for anchoring.
StreamOptions	Collection	A collection of StreamOptions elements.
Stream\Step	32s	The stream source step. Possible values are: 1 – Video 2 – Range 3 – Surface 4 – Section
Stream\ld	32u	The stream source ID.
Type	Boolean	Area to measure: 0 – Object (convex shape above the baseline) 1 – Clearance (concave shape below the baseline)
Type.used	Boolean	Whether or not field is used.
Baseline	Boolean	Baseline type: 0 – X-axis 1 – Line
Baseline.used	Boolean	Whether or not field is used.
RegionEnabled	Boolean	If enabled, the defined region is used for

Element	Type	Description
		measurements. Otherwise, the full active area is used.
Region	ProfileRegion2d	Measurement region.
Line	ProfileLine	Line definition when Baseline is set to Line.
Measurements\Area	Area tool measurement	Area measurement.
Measurements\CentroidX	Area tool measurement	CentroidX measurement.
Measurements\CentroidZ	Area tool measurement	CentroidZ measurement.
Features\CenterPoint	GeometricFeature	CenterPoint PointFeature.

Area Tool Measurement

Element	Type	Description
@id	32s	Measurement ID. Optional (measurement disabled if not set).
Name	String	Measurement name.
Enabled	Boolean	Measurement enable state: 0 – Disable 1 – Enable
HoldEnabled	Boolean	Output hold enable state: 0 – Disable 1 – Enable
SmoothingEnabled	Boolean	Smoothing enable state: 0 – Disable 1 – Enable
PreserveInvalidsEnabled	Boolean	Preserve invalid measurements enable state 0 – Disable 1 – Enable
SmoothingWindow	32u	Smoothing window.
Scale	64f	Output scaling factor.
Offset	64f	Output offset factor.
DecisionMin	64f	Minimum decision threshold.
DecisionMax	64f	Maximum decision threshold.

ProfileBoundingBox

A ProfileBoundingBox element defines settings for a profile bounding box tool and one or more of its measurements.

ProfileBoundingBox Child Elements

Element	Type	Description
@isCustom	Bool	Reserved for future use.
@format	32s	Format type of the tool:

Element	Type	Description
		0 – Standard built-in tool 1 – GDK user-defined tool 2 – Internal GDK tool
@id	32s	The tool's ID.
Name	String	Tool name.
Features	Collection	Collection of geometric feature outputs available in the tool. See <i>ProfileBoundingBox</i> on the previous page.
Source	32s	Profile source.
Anchor\X	String (CSV)	The X measurements (IDs) used for anchoring.
Anchor\X.options	String (CSV)	The X measurements (IDs) available for anchoring.
Anchor\Z	String (CSV)	The Z measurements (IDs) used for anchoring.
Anchor\Z.options	String (CSV)	The Z measurements (IDs) available for anchoring.
StreamOptions	Collection	A collection of StreamOptions elements.
Stream\Step	32s	The stream source step. Possible values are: 1 – Video 2 – Range 3 – Surface 4 – Section
Stream\ld	32u	The stream source ID.
RegionEnabled	Bool	Whether or not to use the region. If the region is disabled, all available data is used.
Region	ProfileRegion2d	Measurement region.
Measurements\X	Bounding Box tool measurement	X measurement.
Measurements\Z	Bounding Box tool measurement	Z measurement.
Measurements\Width	Bounding Box tool measurement	Width measurement.
Measurements\Height	Bounding Box tool measurement	Height measurement.
Measurements\GlobalX	Bounding Box tool measurement	GlobalX measurement
Measurements\GlobalY	Bounding Box tool measurement	GlobalY measurement
Measurements\GlobalAngle	Bounding Box tool measurement	GlobalAngle measurement
Features\CenterPoint	GeometricFeature	CenterPoint PointFeature.
Features\CornerPoint	GeometricFeature	CornerPoint PointFeature.

Bounding Box Tool Measurement

Element	Type	Description
@id	32s	Measurement ID. Optional (measurement disabled if not set).
Name	String	Measurement name.
Enabled	Boolean	Measurement enable state: 0 – Disable 1 – Enable
HoldEnabled	Boolean	Output hold enable state: 0 – Disable 1 – Enable
SmoothingEnabled	Boolean	Smoothing enable state: 0 – Disable 1 – Enable
PreserveInvalidsEnabled	Boolean	Preserve invalid measurements enable state 0 – Disable 1 – Enable
SmoothingWindow	32u	Smoothing window.
Scale	64f	Output scaling factor.
Offset	64f	Output offset factor.
DecisionMin	64f	Minimum decision threshold.
DecisionMax	64f	Maximum decision threshold.

ProfileCircle

A ProfileCircle element defines settings for a profile circle tool and one or more of its measurements.

ProfileCircle Child Elements

Element	Type	Description
@isCustom	Bool	Reserved for future use.
@format	32s	Format type of the tool: 0 – Standard built-in tool 1 – GDK user-defined tool 2 – Internal GDK tool
@id	32s	The tool's ID.
Name	String	Tool name.
Features	Collection	Collection of geometric feature outputs available in the tool. See <i>ProfileCircle</i> above.
Source	32s	Profile source.
Anchor\X	String (CSV)	The X measurements (IDs) used for anchoring.

Element	Type	Description
Anchor\X.options	String (CSV)	The X measurements (IDs) available for anchoring.
Anchor\Z	String (CSV)	The Z measurements (IDs) used for anchoring.
Anchor\Z.options	String (CSV)	The Z measurements (IDs) available for anchoring.
StreamOptions	Collection	A collection of StreamOptions elements.
Stream\Step	32s	The stream source step. Possible values are: 1 – Video 2 – Range 3 – Surface 4 – Section
Stream\ld	32u	The stream source ID.
RegionEnabled	Bool	Whether or not to use the region. If the region is disabled, all available data is used.
Region	ProfileRegion2d	Measurement region.
Measurements\X	Circle tool measurement	X measurement.
Measurements\Z	Circle tool measurement	Z measurement.
Measurements\Radius	Circle tool measurement	Radius measurement.
Measurements\StdDev	CircleMeasurement	Standard deviation measurement
Measurements\MinError	CircleMeasurement	Minimum error measurement
Measurements\MinErrorX	CircleMeasurement	Minimum error X measurement
Measurements\MinErrorZ	CircleMeasurement	Minimum error Z measurement
Measurements\MaxError	CircleMeasurement	Maximum error measurement
Measurements\MaxErrorX	CircleMeasurement	Maximum error X measurement
Measurements\MaxErrorZ	CircleMeasurement	Maximum error Z measurement
Features\CenterPoint	GeometricFeature	CenterPoint PointFeature.

Circle Tool Measurement

Element	Type	Description
@id	32s	Measurement ID. Optional (measurement disabled if not set).
Name	String	Measurement name.
Enabled	Boolean	Measurement enable state: 0 – Disable 1 – Enable
HoldEnabled	Boolean	Output hold enable state: 0 – Disable 1 – Enable
SmoothingEnabled	Boolean	Smoothing enable state: 0 – Disable

Element	Type	Description
		1 – Enable
PreserveInvalidsEnabled	Boolean	Preserve invalid measurements enable state 0 – Disable 1 – Enable
SmoothingWindow	32u	Smoothing window.
Scale	64f	Output scaling factor.
Offset	64f	Output offset factor.
DecisionMin	64f	Minimum decision threshold.
DecisionMax	64f	Maximum decision threshold.

ProfileDimension

A ProfileDimension element defines settings for a profile dimension tool and one or more of its measurements.

ProfileDimension Child Elements

Element	Type	Description
@isCustom	Bool	Reserved for future use.
@format	32s	Format type of the tool: 0 – Standard built-in tool 1 – GDK user-defined tool 2 – Internal GDK tool
@id	32s	The tool's ID.
Name	String	Tool name.
Features	Collection	Not used.
Source	32s	Profile source.
Anchor\X	String (CSV)	The X measurements (IDs) used for anchoring.
Anchor\X.options	String (CSV)	The X measurements (IDs) available for anchoring.
Anchor\Z	String (CSV)	The Z measurements (IDs) used for anchoring.
Anchor\Z.options	String (CSV)	The Z measurements (IDs) available for anchoring.
StreamOptions	Collection	A collection of StreamOptions elements.
Stream\Step	32s	The stream source step. Possible values are: 1 – Video 2 – Range 3 – Surface 4 – Section
Stream\ld	32u	The stream source ID.
RefFeature	ProfileFeature	Reference measurement region.

Element	Type	Description
Feature	ProfileFeature	Measurement region.
Measurements\Width	Dimension tool measurement	Width measurement.
Measurements\Height	Dimension tool measurement	Height measurement.
Measurements\Distance	Dimension tool measurement	Distance measurement.
Measurements\CenterX	Dimension tool measurement	CenterX measurement.
Measurements\CenterZ	Dimension tool measurement	CenterZ measurement.

Dimension Tool Measurement

Element	Type	Description
@id	32s	Measurement ID. Optional (measurement disabled if not set).
Name	String	Measurement name.
Enabled	Boolean	Measurement enable state: 0 – Disable 1 – Enable
HoldEnabled	Boolean	Output hold enable state: 0 – Disable 1 – Enable
SmoothingEnabled	Boolean	Smoothing enable state: 0 – Disable 1 – Enable
PreserveInvalidsEnabled	Boolean	Preserve invalid measurements enable state 0 – Disable 1 – Enable
SmoothingWindow	32u	Smoothing window.
Scale	64f	Output scaling factor.
Offset	64f	Output offset factor.
DecisionMin	64f	Minimum decision threshold.
DecisionMax	64f	Maximum decision threshold.
Absolute	Boolean	Setting for selecting absolute or signed result: <i>(Width and Height measurements only)</i> 0 – Signed 1 – Absolute

ProfileGroove

A ProfileGroove element defines settings for a profile groove tool and one or more of its measurements.

The profile groove tool is dynamic, meaning that it can contain multiple measurements of the same type in the Measurements element.

ProfileGroove Child Elements

Element	Type	Description
@isCustom	Bool	Reserved for future use.
@format	32s	Format type of the tool: 0 - Standard built-in tool 1 - GDK user-defined tool 2 - Internal GDK tool
@id	32s	The tool's ID.
Name	String	Tool name.
Features	Collection	Not used.
Source	32s	Profile source.
Anchor\X	String (CSV)	The X measurements (IDs) used for anchoring.
Anchor\X.options	String (CSV)	The X measurements (IDs) available for anchoring.
Anchor\Z	String (CSV)	The Z measurements (IDs) used for anchoring.
Anchor\Z.options	String (CSV)	The Z measurements (IDs) available for anchoring.
StreamOptions	Collection	A collection of StreamOptions elements.
Stream\Step	32s	The stream source step. Possible values are: 1 - Video 2 - Range 3 - Surface 4 - Section
Stream\ld	32u	The stream source ID.
Shape	32s	Shape: 0 - U-shape 1 - V-shape 2 - Open
MinDepth	64f	Minimum depth.
MinWidth	64f	Minimum width.
MaxWidth	64f	Maximum width.
RegionEnabled	Bool	Whether or not to use the region. If the region is disabled, all available data is used.
Region	ProfileRegion2d	Measurement region.
Measurements\X	Groove tool measurement	X measurement.
Measurements\Z	Groove tool measurement	Z measurement.

Element	Type	Description
Measurements\Width	Groove tool measurement	Width measurement.
Measurements\Depth	Groove tool measurement	Depth measurement.

Groove Tool Measurement

Element	Type	Description
@id	32s	Measurement ID. Optional (measurement disabled if not set).
Name	String	Measurement name.
Enabled	Boolean	Measurement enable state: 0 – Disable 1 – Enable
HoldEnabled	Boolean	Output hold enable state: 0 – Disable 1 – Enable
SmoothingEnabled	Boolean	Smoothing enable state: 0 – Disable 1 – Enable
PreserveInvalidsEnabled	Boolean	Preserve invalid measurements enable state 0 – Disable 1 – Enable
SmoothingWindow	32u	Smoothing window.
Scale	64f	Output scaling factor.
Offset	64f	Output offset factor.
DecisionMin	64f	Minimum decision threshold.
DecisionMax	64f	Maximum decision threshold.
SelectType	32s	Method of selecting a groove when multiple grooves are found: 0 – Max depth 1 – Ordinal, from left 2 – Ordinal, from right
SelectIndex	32s	Index when SelectType is set to 1 or 2.
Location (X and Z measurements only)	32s	Setting for groove location to return from: 0 – Bottom 1 – Left corner 2 – Right corner

ProfileIntersect

A ProfileIntersect element defines settings for a profile intersect tool and one or more of its measurements.

ProfileIntersect Child Elements

Element	Type	Description
@isCustom	Bool	Reserved for future use.
@format	32s	Format type of the tool: 0 – Standard built-in tool 1 – GDK user-defined tool 2 – Internal GDK tool
@id	32s	The tool's ID.
Name	String	Tool name.
Features	Collection	Collection of geometric feature outputs available in the tool. See <i>ProfileIntersect</i> above.
Source	32s	Profile source.
Anchor\X	String (CSV)	The X measurements (IDs) used for anchoring.
Anchor\X.options	String (CSV)	The X measurements (IDs) available for anchoring.
Anchor\Z	String (CSV)	The Z measurements (IDs) used for anchoring.
Anchor\Z.options	String (CSV)	The Z measurements (IDs) available for anchoring.
RefType	32s	Reference line type: 0 – Fit 1 – X Axis
StreamOptions	Collection	A collection of StreamOptions elements.
Stream\Step	32s	The stream source step. Possible values are: 1 – Video 2 – Range 3 – Surface 4 – Section
Stream\ld	32u	The stream source ID.
RefLine	ProfileLine	Definition of reference line. Ignored if RefType is not 0.
Line	ProfileLine	Definition of line.
Measurements\X	Intersect tool measurement	X measurement.
Measurements\Z	Intersect tool measurement	Z measurement.
Measurements\Angle	Intersect tool measurement	Angle measurement.
Features\IntersectPoint	GeometricFeature	IntersectPoint PointFeature.

Element	Type	Description
Features\Line	GeometricFeature	Line LineFeature.
Features\BaseLine	GeometricFeature	BaseLine LineFeature.

Intersect Tool Measurement

Element	Type	Description
@id	32s	Measurement ID. Optional (measurement disabled if not set).
Name	String	Measurement name.
Enabled	Boolean	Measurement enable state: 0 – Disable 1 – Enable
HoldEnabled	Boolean	Output hold enable state: 0 – Disable 1 – Enable
SmoothingEnabled	Boolean	Smoothing enable state: 0 – Disable 1 – Enable
PreserveInvalidsEnabled	Boolean	Preserve invalid measurements enable state 0 – Disable 1 – Enable
SmoothingWindow	32u	Smoothing window.
Scale	64f	Output scaling factor.
Offset	64f	Output offset factor.
DecisionMin	64f	Minimum decision threshold.
DecisionMax	64f	Maximum decision threshold.
Absolute (<i>Angle measurement only</i>)	Boolean	Setting for selecting the angle range: 0 – A range of -90 to 90 degrees is used. 1 – A range of 0 to 180 degrees is used.

ProfileLine

A ProfileLine element defines settings for a profile line tool and one or more of its measurements.

ProfileLine Child Elements

Element	Type	Description
@isCustom	Bool	Reserved for future use.
@format	32s	Format type of the tool: 0 – Standard built-in tool 1 – GDK user-defined tool 2 – Internal GDK tool

Element	Type	Description
@id	32s	The tool's ID.
Name	String	Tool name.
Features	Collection	Collection of geometric feature outputs available in the tool. See <i>ProfileLine</i> on the previous page.
Source	32s	Profile source.
Anchor\X	String (CSV)	The X measurements (IDs) used for anchoring.
Anchor\X.options	String (CSV)	The X measurements (IDs) available for anchoring.
Anchor\Z	String (CSV)	The Z measurements (IDs) used for anchoring.
Anchor\Z.options	String (CSV)	The Z measurements (IDs) available for anchoring.
StreamOptions	Collection	A collection of StreamOptions elements.
Stream\Step	32s	The stream source step. Possible values are: 1 – Video 2 – Range 3 – Surface 4 – Section
Stream\ld	32u	The stream source ID.
RegionEnabled	Bool	Whether or not to use the region. If the region is disabled, all available data is used.
Region	ProfileRegion2d	Measurement region.
FittingRegions	ProfileLine	ProfileLine describing up to 2 regions to fit to.
FittingRegionsEnabled	Bool	Whether the fitting regions are enabled.
Measurements\StdDev	Line tool measurement	StdDev measurement.
Measurements\MaxError	Line tool measurement	MaxError measurement.
Measurements\MinError	Line tool measurement	MinError measurement.
Measurements\Percentile	Line tool measurement	Percentile measurement.
Measurements\Offset	Line tool measurement	Offset measurement.
Measurements\Angle	Line tool measurement	Angle measurement.
Measurements\MinErrorX	Line tool measurement	Minimum Error in X measurement.
Measurements\MinErrorZ	Line tool measurement	Minimum Error in Z measurement.
Measurements\MaxErrorX	Line tool measurement	Maximum Error in X measurement.
Measurements\MaxErrorZ	Line tool measurement	Maximum Error in Z measurement.
Features\Line	GeometricFeature	Line LineFeature.
Features\ErrorMinPoint	GeometricFeature	ErrorMinPoint PointFeature.
Features\ErrorMaxPoint	GeometricFeature	ErrorMaxPoint PointFeature.

Line Tool Measurement

Element	Type	Description
@id	32s	Measurement ID. Optional (measurement disabled if not set).
Name	String	Measurement name.
Enabled	Boolean	Measurement enable state: 0 – Disable 1 – Enable
HoldEnabled	Boolean	Output hold enable state: 0 – Disable 1 – Enable
SmoothingEnabled	Boolean	Smoothing enable state: 0 – Disable 1 – Enable
PreserveInvalidsEnabled	Boolean	Preserve invalid measurements enable state 0 – Disable 1 – Enable
SmoothingWindow	32u	Smoothing window.
Scale	64f	Output scaling factor.
Offset	64f	Output offset factor.
DecisionMin	64f	Minimum decision threshold.
DecisionMax	64f	Maximum decision threshold.
Percent	64f	Error percentile. <i>(Percentile measurement only)</i>

ProfilePanel

A ProfilePanel element defines settings for a profile panel tool and one or more of its measurements.

ProfilePanel Child Elements

Element	Type	Description
@isCustom	Bool	Reserved for future use.
@format	32s	Format type of the tool: 0 – Standard built-in tool 1 – GDK user-defined tool 2 – Internal GDK tool
@id	32s	The tool's ID.
Name	String	Tool name.
Features	Collection	Not used.
Source	32s	Profile source.

Element	Type	Description
Anchor\X	String (CSV)	The X measurements (IDs) used for anchoring.
Anchor\X.options	String (CSV)	The X measurements (IDs) available for anchoring.
Anchor\Z	String (CSV)	The Z measurements (IDs) used for anchoring.
Anchor\Z.options	String (CSV)	The Z measurements (IDs) available for anchoring.
StreamOptions	Collection	A collection of StreamOptions elements.
Stream\Step	32s	The stream source step. Possible values are: 1 – Video 2 – Range 3 – Surface 4 – Section
Stream\ld	32u	The stream source ID.
RefSide	32s	Setting for reference side to use.
MaxGapWidth	64f	Setting for maximum gap width (mm).
LeftEdge	ProfilePanelEdge	Element for left edge configuration.
RightEdge	ProfilePanelEdge	Element for right edge configuration.
Measurements\Gap	Gap/Flush measurement	Gap measurement.
Measurements\Flush	Gap/Flush measurement	Flush measurement.
Measurements\LeftGapX	Gap/Flush measurement	Left Gap X measurement.
Measurements\LeftGapZ	Gap/Flush measurement	Left Gap Z measurement.
Measurements\LeftFlushX	Gap/Flush measurement	Left Flush X measurement.
Measurements\LeftFlushZ	Gap/Flush measurement	Left Flush Z measurement.
Measurements\LeftSurfaceAngle	Gap/Flush measurement	Left Surface Angle measurement.
Measurements\RightGapX	Gap/Flush measurement	Right Gap X measurement.
Measurements\RightGapZ	Gap/Flush measurement	Right Gap Z measurement.
Measurements\RightFlushX	Gap/Flush measurement	Right Flush X measurement.
Measurements\RightFlushZ	Gap/Flush measurement	Right Flush Z measurement.
Measurements\RightSurfaceAngle	Gap/Flush measurement	Right Surface Angle measurement.

ProfilePanelEdge

Element	Type	Description
EdgeType	32s	Edge type: 0 – Tangent 1 – Corner
MinDepth	64f	Minimum depth.
MaxVoidWidth	64f	Maximum void width.
SurfaceWidth	64f	Surface width.
SurfaceOffset	64f	Surface offset.
NominalRadius	64f	Nominal radius.
EdgeAngle	64f	Edge angle.
RegionEnabled	Bool	Whether or not to use the region. If the region is disabled, all available data is used.
Region	ProfileRegion2d	Edge region.

Gap/Flush Measurement

Element	Type	Description
@id	32s	Measurement ID. Optional (measurement disabled if not set).
Name	String	Measurement name.
Enabled	Boolean	Measurement enable state: 0 – Disable 1 – Enable
HoldEnabled	Boolean	Output hold enable state: 0 – Disable 1 – Enable
SmoothingEnabled	Boolean	Smoothing enable state: 0 – Disable 1 – Enable
PreserveInvalidsEnabled	Boolean	Preserve invalid measurements enable state 0 – Disable 1 – Enable
SmoothingWindow	32u	Smoothing window.
Scale	64f	Output scaling factor.
Offset	64f	Output offset factor.
DecisionMin	64f	Minimum decision threshold.
DecisionMax	64f	Maximum decision threshold.
Axis	32s	Measurement axis: <i>(Gap measurement only)</i> 0 – Edge

Element	Type	Description
		1 – Surface 2 – Distance
Absolute (Flush measurement only)	Boolean	Setting for selecting absolute or signed result: 0 – Signed 1 – Absolute

ProfilePosition

A ProfilePosition element defines settings for a profile position tool and one or more of its measurements.

ProfilePosition Child Elements

Element	Type	Description
@isCustom	Bool	Reserved for future use.
@format	32s	Format type of the tool: 0 – Standard built-in tool 1 – GDK user-defined tool 2 – Internal GDK tool
@id	32s	The tool's ID.
Name	String	Tool name.
Features	Collection	Collection of geometric feature outputs available in the tool. See <i>ProfilePosition</i> above.
Source	32s	Profile source.
Anchor\X	String (CSV)	The X measurements (IDs) used for anchoring.
Anchor\X.options	String (CSV)	The X measurements (IDs) available for anchoring.
Anchor\Z	String (CSV)	The Z measurements (IDs) used for anchoring.
Anchor\Z.options	String (CSV)	The Z measurements (IDs) available for anchoring.
StreamOptions	Collection	A collection of StreamOptions elements.
Stream\Step	32s	The stream source step. Possible values are: 1 – Video 2 – Range 3 – Surface 4 – Section
Stream\ld	32u	The stream source ID.
Feature	ProfileFeature	Element for feature detection.
Measurements\X	Position tool measurement	X measurement.
Measurements\Z	Position tool measurement	Z measurement.
Features\Point	GeometricFeature	Point PointFeature

Position Tool Measurement

Element	Type	Description
id (attribute)	32s	Measurement ID. Optional (measurement disabled if not set).
Name	String	Measurement name.
Enabled	Boolean	Measurement enable state: 0 – Disable 1 – Enable
HoldEnabled	Boolean	Output hold enable state: 0 – Disable 1 – Enable
SmoothingEnabled	Boolean	Smoothing enable state: 0 – Disable 1 – Enable
PreserveInvalidsEnabled	Boolean	Preserve invalid measurements enable state 0 – Disable 1 – Enable
SmoothingWindow	32u	Smoothing window.
Scale	64f	Output scaling factor.
Offset	64f	Output offset factor.
DecisionMin	64f	Minimum decision threshold.
DecisionMax	64f	Maximum decision threshold.

ProfileRoundCorner

A ProfileRoundCorner element defines settings for a profile round corner tool and one or more of its measurements.

ProfileRoundCorner Child Elements

Element	Type	Description
@isCustom	Bool	Reserved for future use.
@format	32s	Format type of the tool: 0 – Standard built-in tool 1 – GDK user-defined tool 2 – Internal GDK tool
@id	32s	The tool's ID.
Name	String	Tool name.
Features	Collection	Not used.
Source	32s	Profile source.
Anchor\X	String (CSV)	The X measurements (IDs) used for anchoring.

Element	Type	Description
Anchor\X.options	String (CSV)	The X measurements (IDs) available for anchoring.
Anchor\Z	String (CSV)	The Z measurements (IDs) used for anchoring.
Anchor\Z.options	String (CSV)	The Z measurements (IDs) available for anchoring.
StreamOptions	Collection	A collection of StreamOptions elements.
Stream\Step	32s	The stream source step. Possible values are: 1 - Video 2 - Range 3 - Surface 4 - Section
Stream\ld	32u	The stream source ID.
RefDirection	32s	Setting for reference side to use: 0 - Left 1 - Right
Edge	ProfilePanelEdge	Element for edge configuration
Measurements\X	Round Corner tool measurement	X measurement.
Measurements\Z	Round Corner tool measurement	Z measurement.
Measurements\Angle	Round Corner tool measurement	Angle measurement.
Features\CenterPoint	Geometric Feature	Circle Center PointFeature.
Features\EdgePoint	Geometric Feature	Edge PointFeature.

ProfilePanelEdge

Element	Type	Description
EdgeType	32s	Edge type: 0 - Tangent 1 - Corner
MinDepth	64f	Minimum depth.
MaxVoidWidth	64f	Maximum void width.
SurfaceWidth	64f	Surface width.
SurfaceOffset	64f	Surface offset.
NominalRadius	64f	Nominal radius.
EdgeAngle	64f	Edge angle.
RegionEnabled	Bool	Whether or not to use the region. If the region is disabled, all available data is used.
Region	ProfileRegion2d	Edge region.

Round Corner Tool Measurement

Element	Type	Description
id (attribute)	32s	Measurement ID. Optional (measurement disabled if not set).
Name	String	Measurement name.
Enabled	Boolean	Measurement enable state: 0 – Disable 1 – Enable
HoldEnabled	Boolean	Output hold enable state: 0 – Disable 1 – Enable
PreserveInvalidsEnabled	Boolean	Preserve invalid measurements enable state 0 – Disable 1 – Enable
SmoothingEnabled	Boolean	Smoothing enable state: 0 – Disable 1 – Enable
SmoothingWindow	32u	Smoothing window.
Scale	64f	Output scaling factor.
Offset	64f	Output offset factor.
DecisionMin	64f	Minimum decision threshold.
DecisionMax	64f	Maximum decision threshold.

ProfileStrip

A ProfileStrip element defines settings for a profile strip tool and one or more of its measurements.

The profile strip tool is dynamic, meaning that it can contain multiple measurements of the same type in the Measurements element.

ProfileStrip Child Elements

Element	Type	Description
@isCustom	Bool	Reserved for future use.
@format	32s	Format type of the tool: 0 – Standard built-in tool 1 – GDK user-defined tool 2 – Internal GDK tool
@id	32s	The tool's ID.
Name	String	Tool name.
Features	Collection	Not used.
Source	32s	Profile source.

Element	Type	Description
Anchor\X	String (CSV)	The X measurements (IDs) used for anchoring.
Anchor\X.options	String (CSV)	The X measurements (IDs) available for anchoring.
Anchor\Z	String (CSV)	The Z measurements (IDs) used for anchoring.
Anchor\Z.options	String (CSV)	The Z measurements (IDs) available for anchoring.
StreamOptions	Collection	A collection of StreamOptions elements.
Stream\Step	32s	The stream source step. Possible values are: 1 - Video 2 - Range 3 - Surface 4 - Section
Stream\ld	32u	The stream source ID.
BaseType	32s	Setting for the strip type: 0 - None 1 - Flat
LeftEdge	Bitmask	Setting for the left edge conditions: 1 - Raising 2 - Falling 4 - Data End 8 - Void
RightEdge	Bitmask	Setting for the right edge conditions: 1 - Raising 2 - Falling 4 - Data End 8 - Void
TiltEnabled	Boolean	Setting for tilt compensation: 0 - Disabled 1 - Enabled
SupportWidth	64f	Support width of edge (mm).
TransitionWidth	64f	Transition width of edge (mm).
MinWidth	64f	Minimum strip width (mm).
MinHeight	64f	Minimum strip height (mm).
MaxVoidWidth	64f	Void max (mm).
Region	ProfileRegion2d	Region containing the strip.
Measurements\X	Strip tool measurement	X measurement.
Measurements\Z	Strip tool measurement	Z measurement.
Measurements\Width	Strip tool measurement	Width measurement.
Measurements\Height	Strip tool measurement	Width measurement.

Strip Tool Measurement

Element	Type	Description
@id	32s	Measurement ID. Optional (measurement disabled if not set).
Name	String	Measurement name.
Enabled	Boolean	Measurement enable state: 0 – Disable 1 – Enable
HoldEnabled	Boolean	Output hold enable state: 0 – Disable 1 – Enable
SmoothingEnabled	Boolean	Smoothing enable state: 0 – Disable 1 – Enable
PreserveInvalidsEnabled	Boolean	Preserve invalid measurements enable state 0 – Disable 1 – Enable
SmoothingWindow	32u	Smoothing window.
Scale	64f	Output scaling factor.
Offset	64f	Output offset factor.
DecisionMin	64f	Minimum decision threshold.
DecisionMax	64f	Maximum decision threshold.
SelectType	32s	Method of selecting a groove when multiple grooves are found: 0 – Best 1 – Ordinal, from left 2 – Ordinal, from right
SelectIndex	32s	Index when SelectType is set to 1 or 2.
Location <i>(X, Z, and Height measurements only)</i>	32s	Setting for groove location to return from: 0 – Left 1 – Right 2 – Center

Script

A Script element defines settings for a script measurement.

Script Child Elements

Element	Type	Description
@isCustom	Bool	Reserved for future use.
@format	32s	Format type of the tool:

Element	Type	Description
		0 – Standard built-in tool 1 – GDK user-defined tool 2 – Internal GDK tool
@id	32s	The tool's ID.
Name	String	Tool name.
Code	String	Script code.
Measurements\Output	(Collection)	Dynamic list of Output elements.

Output

Element	Type	Description
@id	32s	Measurement ID. Optional (measurement disabled if not set).
Name	String	Measurement name.

Tool (type FeatureDimension)

A Tool element of type FeatureDimension defines settings for a feature dimension tool and one or more of its measurements.

Tool Child Elements

Element	Type	Description
@isCustom	Bool	Reserved for future use.
@format	32s	Format type of the tool: 0 – Standard built-in tool 1 – GDK user-defined tool 2 – Internal GDK tool
@id	32s	The tool's ID.
@type	String	Type name of the tool.
@version	String	Version string for custom tool.
Name	String	Tool name.
Source	32s	Surface source.
Anchor\X	String (CSV)	The X measurements (IDs) used for anchoring.
Anchor\X.options	String (CSV)	The X measurements (IDs) available for anchoring.
Anchor\Y	String (CSV)	The Y measurements (IDs) used for anchoring.
Anchor\Y.options	String (CSV)	The Y measurements (IDs) available for anchoring.
Anchor\Z	String (CSV)	The Z measurements (IDs) used for anchoring.

Element	Type	Description
Anchor\Z.options	String (CSV)	The Z measurements (IDs) available for anchoring.
Parameters\RefPoint	GdkParamGeometricFeature	Reference point feature.
Parameters\Feature	GdkParamGeometricFeature	Reference feature.
Measurements\Measurement @type=Width	Dimension Measurement	Width measurement.
Measurements\Measurement @type=Length	Dimension Measurement	Length measurement.
Measurements\Measurement @type=Height	Dimension Measurement	Width measurement.
Measurements\Measurement @type=Distance	Dimension Measurement	Distance measurement.
Measurements\Measurement @type=PlaneDistance	Dimension Measurement	Plane distance measurement.
<i>Dimension Measurement Child Elements</i>		
@id	32s	Measurement ID. Optional (measurement disabled if not set).
@type	String	Type name of measurement.
Name	String	Measurement name.
Enabled	Boolean	Measurement enable state: 0 – Disable 1 – Enable
HoldEnabled	Boolean	Output hold enable state: 0 – Disable 1 – Enable
SmoothingEnabled	Boolean	Smoothing enable state: 0 – Disable 1 – Enable
PreserveInvalidsEnabled	Boolean	Preserve invalid measurements enable state 0 – Disable 1 – Enable
SmoothingWindow	32u	Smoothing window.
Scale	64f	Output scaling factor.
Offset	64f	Output offset factor.
DecisionMin	64f	Minimum decision threshold.
DecisionMax	64f	Maximum decision threshold.
Parameters\WidthAbsolute <i>(Width measurement only)</i>	GdkParamBool	Absolute width enabled boolean.

Parameters\LengthAbsolute (Length measurement only)	GdkParamBool	Absolute length enabled boolean.
Parameters\HeightAbsolute (Height measurement only)	GdkParamBool	Absolute height enabled boolean.

Tool (type FeatureIntersect)

A Tool element of type FeatureIntersect defines settings for a feature intersection tool and one or more of its measurements.

Tool Child Elements

Element	Type	Description
@isCustom	Bool	Reserved for future use.
@format	32s	Format type of the tool: 0 – Standard built-in tool 1 – GDK user-defined tool 2 – Internal GDK tool
@id	32s	The tool's ID.
@type	String	Type name of the tool.
@version	String	Version string for custom tool.
Name	String	Tool name.
Source	32s	Surface source.
Anchor\X	String (CSV)	The X measurements (IDs) used for anchoring.
Anchor\X.options	String (CSV)	The X measurements (IDs) available for anchoring.
Anchor\Y	String (CSV)	The Y measurements (IDs) used for anchoring.
Anchor\Y.options	String (CSV)	The Y measurements (IDs) available for anchoring.
Anchor\Z	String (CSV)	The Z measurements (IDs) used for anchoring.
Anchor\Z.options	String (CSV)	The Z measurements (IDs) available for anchoring.
Parameters\Line	GdkParamGeometricFeature	Line feature input.
Parameters\RefLine	GdkParamGeometricFeature	Reference line feature input.
Measurements\Measurement @type=X	Intersect Measurement	X measurement.
Measurements\Measurement @type=Y	Intersect Measurement	Y measurement.
Measurements\Measurement @type=Z	Intersect Measurement	Z measurement.

Element	Type	Description
Measurements\Measurement @type=Angle	Intersect Measurement	Angle measurement.
Features\IntersectPoint	GDK Feature	Intersect point feature.

Intersect Measurement Child Elements

@id	32s	Measurement ID. Optional (measurement disabled if not set).
@type	String	Type name of measurement.
Name	String	Measurement name.
Enabled	Boolean	Measurement enable state: 0 - Disable 1 - Enable
HoldEnabled	Boolean	Output hold enable state: 0 - Disable 1 - Enable
SmoothingEnabled	Boolean	Smoothing enable state: 0 - Disable 1 - Enable
PreserveInvalidsEnabled	Boolean	Preserve invalid measurements enable state 0 - Disable 1 - Enable
SmoothingWindow	32u	Smoothing window.
Scale	64f	Output scaling factor.
Offset	64f	Output offset factor.
DecisionMin	64f	Minimum decision threshold.
DecisionMax	64f	Maximum decision threshold.
Parameters\AngleRange	GdkParamInt	Angle range option choice. Is one of: 0 - -180 To 180 1 - 0 To 360

Custom

A Custom element defines settings for a user-created GDK-based tool and one or more of its measurements.

Custom Child Elements

Element	Type	Description
@type	String	Type name of the tool.
@version	String	Version string for custom tool.
Name	String	Tool name.

Element	Type	Description
Source	32s	Surface source.
Anchor\X	String (CSV)	The X measurements (IDs) used for anchoring.
Anchor\X.options	String (CSV)	The X measurements (IDs) available for anchoring.
Anchor\Y	String (CSV)	The Y measurements (IDs) used for anchoring.
Anchor\Y.options	String (CSV)	The Y measurements (IDs) available for anchoring.
Anchor\Z	String (CSV)	The Z measurements (IDs) used for anchoring.
Anchor\Z.options	String (CSV)	The Z measurements (IDs) available for anchoring.
Parameters	GDK Parameter	Collection of parameters . The element name in the job file is the name of the parameter.
Measurements	GDK Measurement	Collection of measurements .
Features	GDK Feature	Collection of features .

Output

The Output element contains the following sub-elements: Ethernet, Serial, Analog, Digital0, and Digital1. Each of these sub-elements defines the output settings for a different type of output.

For all sub-elements, the source identifiers used for measurement outputs correspond to the measurement identifiers defined in each tool's Measurements element. For example, in the following XML, in the options attribute of the Measurements element, 2 and 3 are the identifiers of measurements that are enabled and available for output. The value of the Measurements element (that is, 2) means that only the measurement with id 2 (Range Position Z) will be sent to output.

```
<RangePosition>    ...
  <Measurements>
    <Z id="2">    ...
<RangeThickness>  ...
  <Measurements>
    <Thickness id="3">  ...

<Output>
  <Ethernet>    ...
    <Measurements options="2,3">2</Measurements>
```

Ethernet

The Ethernet element defines settings for Ethernet output.

In the Ethernet element, the source identifiers used for video, range, profile, and surface output, as well as range, profile, and surface intensity outputs, correspond to the *sensor* that provides the data. For example, in the XML below, the *options* attribute of the Ranges element shows that only two sources are available (see the table below for the meanings of these values). The value in this element—0—indicates that only data from that source will be sent to output.

```
<Output>
```

```

<Ethernet>
  ...
  <Ranges options="0,1">0</Ranges>
  <Profiles options=""/>>
  <Surfaces options=""/>
  ...

```

Ethernet Child Elements

Element	Type	Description
Ethernet.used	Boolean	Indicates if the output is available on the sensor.
Protocol	32s	Ethernet protocol: 0 – Gocator 1 – Modbus 2 – EtherNet/IP 3 – ASCII 4 – PROFINET
Protocol.options	32s (CSV)	List of available protocol options.
TimeoutEnabled	Boolean	Enable or disable auto-disconnection timeout. Applies only to the Gocator protocol.
Timeout	64f	Disconnection timeout (seconds). Used when TimeoutEnabled is true and the Gocator protocol is selected.
Ascii	Section	See <i>Ascii</i> on page 336.
EIP	Section	See <i>EIP</i> on page 336.
Modbus	Section	See <i>Modbus</i> on page 337.
Profinet	Section	See <i>Profinet</i> on page 337.
Ptp	Section	Enable or disable Precision Time Protocol support.
Videos	32s (CSV)	Selected video sources: 0 – Top 1 – Bottom 2 – Top left 3 – Top right
Videos.options	32s (CSV)	List of available video sources (see above).
Ranges	32s (CSV)	Selected range sources: 0 – Top 1 – Bottom 2 – Top left 3 – Top right
Ranges.options	32s (CSV)	List of available range sources (see above).
Profiles	32s (CSV)	Selected profile sources:

Element	Type	Description
		0 - Top 1 - Bottom 2 - Top left 3 - Top right
Profiles.options	32s (CSV)	List of available profile sources (see above).
Surfaces	32s (CSV)	Selected surface sources: 0 - Top 1 - Bottom 2 - Top left 3 - Top right
Surfaces.options	32s (CSV)	List of available surface sources (see above).
SurfaceSections	32s (CSV)	Selected surface section sources.
SurfaceSections.options	32s (CSV)	List of available surface section sources.
RangeIntensities	32s (CSV)	Selected range intensity sources. 0 - Top 1 - Bottom 2 - Top left 3 - Top right
RangeIntensities.options	32s (CSV)	List of available range intensity sources (see above).
ProfileIntensities	32s (CSV)	Selected profile intensity sources. 0 - Top 1 - Bottom 2 - Top left 3 - Top right
ProfileIntensities.options	32s (CSV)	List of available profile intensity sources (see above).
SurfaceIntensities	32s (CSV)	Selected surface intensity sources.
SurfaceIntensities.options	32s (CSV)	List of available surface intensity sources (see above).
SurfaceSectionIntensities	32s (CSV)	Selected surface section intensity sources
SurfaceSectionIntensities.options	32s (CSV)	List of available surface section intensity sources.
Tracheids	32s (CSV)	Selected tracheid sources.
Tracheids.options	32s (CSV)	List of available tracheid sources.
Measurements	32u (CSV)	Selected measurement sources.
Measurements.options	32u (CSV)	List of available measurement sources.
Events	32u (CSV)	Selected events
Events.Options	32u (CSV)	CSV list of possible event options: 0 - Exposure Begins

Element	Type	Description
		1 – Exposure Ends
Features	32u (CSV)	Selected feature sources.
Features.options	32u (CSV)	List of available feature sources.
ToolData	32u (CSV)	Selected tool data sources.
ToolData.options	32u (CSV)	List of available tool data sources.

Ascii

Ascii Child Elements

Element	Type	Description
Operation	32s	Operation mode: 0 – Asynchronous 1 – Polled
ControlPort	32u	Control service port number.
HealthPort	32u	Health service port number.
DataPort	32u	Data service port number.
Delimiter	String	Field delimiter.
Terminator	String	Line terminator.
InvalidValue	String	String for invalid output.
CustomDataFormat	String	Custom data format.
CustomFormatEnabled	Bool	Enables custom data format.
StandardFormatMode	32u	The formatting mode used if not a custom format: 0 – Standard 1 – Standard with Stamp

EIP

EIP Child Elements

Element	Type	Description
BufferEnabled	Bool	Enables EtherNet/IP output buffering.
EndianOutputType	32s	Endian output type: 0 – Big endian 1 – Little endian
ImplicitOutputEnabled	Bool	Enables Implicit (I/O) Messaging.
ImplicitTriggerOverride	32s	Override requested trigger type by client: 0 – No override 1 – Cyclic 2 – Change of State

Modbus

Modbus Child Elements

Element	Type	Description
BufferEnabled	Bool	Enables Modbus output buffering.

Profinet

PROFINET is not supported on Gocator point profile sensors (Gocator 1300 series).

Digital0 and Digital1

The Digital0 and Digital1 elements define settings for a sensor's two digital outputs.

Digital0 and Digital1 Child Elements

Element	Type	Description
Digital0.used	Boolean	Indicates if the output is available on the sensor.
Event	32s	Triggering event: 0 – None (disabled) 1 – Measurements 2 – Software 3 – Alignment state 4 – Acquisition start 5 – Acquisition end
SignalType	32s	Signal type: 0 – Pulse 1 – Continuous
ScheduleEnabled	Bool	Enables scheduling.
PulseWidth	64f	Pulse width (μ s).
PulseWidth.min	64f	Minimum pulse width (μ s).
PulseWidth.max	64f	Maximum pulse width (μ s).
PassMode	32s	Measurement pass condition: 0 – AND of measurements is true 1 – AND of measurements is false 2 – Always assert
Delay	64f	Output delay (μ s or mm, depending on delay domain defined below).
DelayDomain	32s	Output delay domain: 0 – Time (μ s) 1 – Encoder (mm)
Inverted	Bool	Whether the sent bits are flipped.
Measurements	32u (CSV)	Selected measurement sources.
Measurements.options	32u (CSV)	List of available measurement sources.

Analog

The Analog element defines settings for analog output.

The range of valid measurement values [DataScaleMin, DataScaleMax] is scaled linearly to the specified current range [CurrentMin, CurrentMax].

Only one Value or Decision source can be selected at a time.

 Gocator 1300 series sensors are limited to sending data at 10 kHz over the analog output channel. Therefore, if you configure a sensor so that it runs at a speed higher than 10 kHz, and configure a measurement to be sent on the analog channel, you will get analog data drops. To achieve a 10 kHz analog output rate, you must enable and configure scheduled output.

Analog Child Elements

Element	Type	Description
Analog.used	Boolean	Indicates if the output is available on the sensor.
Event	32s	Triggering event: 0 – None (disabled) 1 – Measurements 2 – Software
ScheduleEnabled	Bool	Enables scheduling.
CurrentMin	64f	Minimum current (mA).
CurrentMin.min	64f	Minimum value of minimum current (mA).
CurrentMin.max	64f	Maximum value of minimum current (mA).
CurrentMax	64f	Maximum current (mA).
CurrentMax.min	64f	Minimum value of maximum current (mA).
CurrentMax.max	64f	Maximum value of maximum current (mA).
CurrentInvalidEnabled	Bool	Enables special current value for invalid measurement value.
CurrentInvalid	64f	Current value for invalid measurement value (mA).
CurrentInvalid.min	64f	Minimum value for invalid current (mA).
CurrentInvalid.max	64f	Maximum value for invalid current (mA).
DataScaleMax	64f	Measurement value corresponding to maximum current.
DataScaleMin	64f	Measurement value corresponding to minimum current.
Delay	64f	Output delay (μ s or mm, depending on delay domain defined below).
DelayDomain	32s	Output delay domain: 0 – Time (μ s) 1 – Encoder (mm)
Measurement	32u	Selected measurement source.
Measurement.options	32u (CSV)	List of available measurement sources.

 The delay specifies the time or position at which the analog output activates. Upon activation, there is an additional delay before the analog output settles at the correct value.

Serial

The Serial element defines settings for Serial output.

Serial Child Elements

Element	Type	Description
Serial.used	Boolean	Indicates if the output is available on the sensor.
Protocol	32s	Serial protocol: 0 – ASCII 1 – Selcom
Protocol.options	32s (CSV)	List of available protocols.
Selcom	Section	See <i>Selcom</i> below.
Ascii	Section	See <i>Ascii</i> below.
Measurements	32u (CSV)	Selected measurement sources.
Measurements.options	32u (CSV)	List of available measurement sources.

Selcom

Selcom Child Elements

Element	Type	Description
Rate	32u	Output bit rate.
Rate.options	32u (CSV)	List of available rates.
Format	32s	Output format: 0 – 12-bit 1 – 12-bit with search 2 – 14-bit 3 – 14-bit with search
Format.options	32s (CSV)	List of available formats.
DataScaleMin	64f	Measurement value corresponding to minimum word value.
DataScaleMax	64f	Measurement value corresponding to maximum word value.
Delay	64u	Output delay in μ s.

Ascii

Ascii Child Elements

Element	Type	Description
Rate	32u	Output bit rate.
Rate.options	32u (CSV)	List of available rates.
Delimiter	String	Field delimiter.
Terminator	String	Line terminator.
InvalidValue	String	String for invalid output.
CustomDataFormat	String	Custom data format.

Element	Type	Description
CustomFormatEnabled	Bool	Enables custom data format.
StandardFormatMode	32u	The formatting mode used if not a custom format: 0 – Standard 1 – Standard with Stamp

Transform

The transformation component contains information about the physical system setup that is used to:

- Transform data from sensor coordinate system to another coordinate system (e.g., world)
- Define encoder resolution for encoder-based triggering
- Define the travel offset (Y offset) between sensors for staggered operation

You can access the Transform component of the active job as an XML file, either using path notation, via "_live.job/transform.xml", or directly via "_live.tfm".

You can access the Transform component in user-created job files in non-volatile storage, for example, "productionRun01.job/transform.xml". You can only access transformations in user-created job files using path notation.

See the following sections for the elements contained in this component.

Transformation Example:

```
<?xml version="1.0" encoding="UTF-8"?>
<Transform version="100">
  <EncoderResolution>1</EncoderResolution>
  <Speed>100</Speed>
  <Devices>
    <Device role="0">
      <X>-2.3650924829</X>
      <Y>0.0</Y>
      <Z>123.4966803469</Z>
      <XAngle>5.7478302588</XAngle>
      <YAngle>3.7078302555</XAngle>
      <ZAngle>2.7078302556</XAngle>
    </Device>
    <Device id="1">
      <X>0</X>
      <Y>0.0</Y>
      <Z>123.4966803469</Z>
      <XAngle>5.7478302588</XAngle>
      <YAngle>3.7078302555</XAngle>
      <ZAngle>2.7078302556</XAngle>
    </Device>
  </Devices>
</Transform>
```

```

    </Devices>
</Transform>

```

The Transform element contains the alignment record for both the Main and the Buddy sensor.

Transform Child Elements

Element	Type	Description
@version	32u	Major transform version (100).
@versionMinor	32u	Minor transform version (0).
EncoderResolution	64f	Encoder Resolution (mm/tick).
Speed	64f	Travel Speed (mm/s).
Devices	(Collection)	Contains two Device elements.

Device

A Device element defines the transformation for a sensor. There is one entry element per sensor, identified by a unique role attribute (0 for main and 1 for buddy):

Device Child Elements

Element	Type	Description
@role	32s	Role of device described by this section: 0 – Main 1 – Buddy
X	64f	Translation on the X axis (mm).
Y	64f	Translation on the Y axis (mm).
Z	64f	Translation on the Z axis (mm).
XAngle	64f	Rotation around the X axis (degrees).
YAngle	64f	Rotation around the Y axis (degrees).
ZAngle	64f	Rotation around the Z axis (degrees).

The rotation (counter-clockwise in the X-Z plane) is performed before the translation.

Integrations

Several integration tools are provided in the Tools package available from the [Downloads](#) center, in the Software subsection for your sensor model and Gocator software release.

- GenICam GenTL driver (see below)
- LabVIEW integration (for more information, see the LabVIEW application guide at <https://downloads.lmi3d.com/interfacing-gocator-labview-4x-guide>).
- EtherNet/IP files
- MountainsMap transfer tool (see below)

Protocols

Gocator supports protocols for communicating with sensors over Ethernet (TCP/IP) and serial output. For a protocol to output data, it must be enabled and configured in the active job.



If you switch jobs or make changes to a job using the SDK or a protocol (from a PLC), the switch or changes are not automatically displayed in the web interface: you must refresh the browser to see these.

Protocols available over Ethernet

- [Gocator](#)
- [Modbus](#)
- [EtherNet/IP](#)
- [ASCII](#)

For an overview of the Ethernet ports used by sensors, see *Required Ports* on page 48.

Protocols available over serial

- [ASCII](#)
- [Selcom](#)

Gocator Protocol

This section describes the TCP and UDP commands and data formats used by a client computer to communicate with Gocator sensors using the Gocator protocol. It also describes the connection types (Discovery, Control, Upgrade, Data, and Health), and data types. The protocol enables the client to:

- Discover Main and Buddy sensors on an IP network and re-configure their network addresses.
- Configure Main and Buddy sensors.
- Send commands to run sensors, provide software triggers, read/write files, etc.

- Receive data, health, and diagnostic messages.
- Upgrade firmware.

 The Gocator 4.x/5.x firmware uses mm, mm², mm³, and degrees as standard units. In all protocols, values are scaled by 1000, as values in the protocols are represented as integers. This results in effective units of mm/1000, mm²/1000, mm³/1000, and deg/1000 in the protocols.

To use the protocol, it must be enabled and configured in the active job.

 Sensors send UDP broadcasts over the network over the Internal Discovery channel (port 2016) at regular intervals during operation to perform peer discovery.

 The Gocator SDK provides open source C language libraries that implement the network commands and data formats defined in this section. For more information, see *GoSDK* on page 480.

For information on configuring the protocol using the web interface, see *Ethernet Output* on page 235.

For information on job file structures (for example, if you wish to create job files programmatically), see *Job File Structure* on page 273.

Data Types

The table below defines the data types and associated type identifiers used in this section.

All values except for IP addresses are transmitted in little endian format (least significant byte first) unless stated otherwise. The bytes in an IP address "a.b.c.d" will always be transmitted in the order a, b, c, d (big endian).

Data Types

Type	Description	Null Value
char	Character (8-bit, ASCII encoding)	-
byte	Byte.	-
8s	8-bit signed integer.	-128
8u	8-bit unsigned integer.	255U
16s	16-bit signed integer.	-32768 (0x8000)
16u	16-bit unsigned integer.	65535 (0xFFFF)
32s	32-bit signed integer.	-2147483648 (0x80000000)
32u	32-bit unsigned integer.	4294967295 (0xFFFFFFFF)
64s	64-bit signed integer.	-9223372036854775808 (0x8000000000000000)
64u	64-bit unsigned integer.	18446744073709551615 (0xFFFFFFFFFFFFFFFF)
64f	64-bit floating point	-1.7976931348623157e+308
Point16s	Two 16-bit signed integers	-
Point64f	Two 64-bit floating point values	-

Type	Description	Null Value
Point3d64f	Three 64-bit floating point values	-
Rect64f	Four 64-bit floating point values	-
Rect3d64f	Eight 64-bit floating point values	-

Commands

The following sections describe the commands available on the Discovery (page 344), Control (page 347), and Upgrade (page 385) channels.

When a client sends a command over the Control or Upgrade channel, the sensor sends a reply whose identifier is the same as the command's identifier. The identifiers are listed in the tables of each of the commands.

Status Codes

Each reply on the Discovery, Control, and Upgrade channels contains a *status* field containing a status code indicating the result of the command. The following status codes are defined:

Status Codes

Label	Value	Description
OK	1	Command succeeded.
Failed	0	Command failed.
Invalid State	-1000	Command is not valid in the current state.
Item Not Found	-999	A required item (e.g., file) was not found.
Invalid Command	-998	Command is not recognized.
Invalid Parameter	-997	One or more command parameters are incorrect.
Not Supported	-996	The operation is not supported.
Simulation Buffer Empty	-992	The simulation buffer is empty.

Discovery Commands

Sensors ship with the following default network configuration:

Setting	Default
DHCP	0 (disabled)
IP Address	192.168.1.10
Subnet Mask	255.255.255.0
Gateway	0.0.0.0 (disabled)

Use the [Get Address](#) and [Set Address](#) commands to modify a sensor's network configuration. These commands are UDP broadcast messages:

Destination Address	Destination Port
255.255.255.255	3220

When a sensor accepts a discovery command, it will send a UDP broadcast response:

Destination Address	Destination Port
255.255.255.255	Port of command sender.

The use of UDP broadcasts for discovery enables a client computer to locate a sensor when the sensor and client are configured for different subnets. All you need to know is the serial number of the sensor in order to locate it on an IP network.

Get Address

The Get Address command is used to discover sensors across subnets.

Command

Field	Type	Offset	Description
length	64s	0	Command length.
type	64s	8	Command type (0x1).
signature	64s	16	Message signature (0x0000504455494D4C)
deviceld	64s	24	Serial number of the device whose address information is queried. 0 selects all devices.

Reply

Field	Type	Offset	Description
length	64s	0	Reply length.
type	64s	8	Reply type (0x1001).
status	64s	16	Operation status.
signature	64s	24	Message signature (0x0000504455494D4C)
deviceld	64s	32	Serial number.
dhcpEnabled	64s	40	0 - Disabled 1 - Enabled
reserved[4]	byte	48	Reserved.
address[4]	byte	52	The IP address in left to right order.
reserved[4]	byte	56	Reserved.
subnetMask[4]	byte	60	The subnet mask in left to right order.
reserved[4]	byte	64	Reserved.
gateway[4]	byte	68	The gateway address in left to right order.
reserved[4]	byte	72	Reserved.
reserved[4]	byte	76	Reserved.

Set Address

The Set Address command modifies the network configuration of a sensor. On receiving the command, the sensor will perform a reset. You should wait 30 seconds before re-connecting to the sensor.

Command

Field	Type	Offset	Description
length	64s	0	Command length.

Field	Type	Offset	Description
type	64s	8	Command type (0x2).
signature	64s	16	Message signature (0x0000504455494D4C)
deviceld	64s	24	Serial number of the device whose address information is queried. 0 selects all devices.
dhcpEnabled	64s	32	0 – Disabled 1 – Enabled
reserved[4]	byte	40	Reserved.
address[4]	byte	44	The IP address in left to right order.
reserved[4]	byte	48	Reserved.
subnetMask[4]	byte	52	The subnet mask in left to right order.
reserved[4]	byte	56	Reserved.
gateway[4]	byte	60	The gateway address in left to right order.
reserved[4]	byte	64	Reserved.
reserved[4]	byte	68	Reserved.

Reply

Field	Type	Offset	Description
length	64s	0	Reply length.
type	64s	8	Reply type (0x1002).
status	64s	16	Operation status. For a list of status codes, see <i>Commands</i> on page 344.
signature	64s	24	Message signature (0x0000504455494D4C).
deviceld	64s	32	Serial number.

Get Info

The Get Info command is used to retrieve sensor information.

Command

Field	Type	Offset	Description
length	64s	0	Command length.
type	64s	8	Command type (0x5).
signature	64s	16	Message signature (0x0000504455494D4C).
deviceld	64s	24	Serial number of the device whose address information is queried. 0 selects all devices.

Reply

Field	Type	Offset	Description
length	64s	0	Reply length.
type	64s	8	Reply type (0x1005).
status	64s	16	Operation status. For a list of status codes, see <i>Commands</i> on page 344.

Field	Type	Offset	Description
signature	64s	24	Message signature (0x0000504455494D4C).
attrCount	16u	32	Byte count of the attributes (begins after this field and ends before propertyCount).
id	32u	34	Serial number.
version	32u	38	Version as a 4-byte integer (encoded in little-endian).
uptime	64u	42	Sensor uptime (microseconds).
ipNegotiation	byte	50	IP negotiation type: 0 – Static 1 – DHCP
addressVersion	byte	51	IP address version (always 4).
address[4]	byte	52	IP address.
reserved[12]	byte	56	Reserved.
prefixLength	32u	68	Subnet prefix length (in number of bits).
gatewayVersion	byte	72	Gateway address version (always 4).
gatewayAddress[4]	byte	73	Gateway address.
reserved[12]	byte	77	Reserved.
controlPort	16u	89	Control channel port.
upgradePort	16u	91	Upgrade channel port.
healthPort	16u	93	Health channel port.
dataPort	16u	95	Data channel port.
webPort	16u	97	Web server port.
propertyCount	8u	99	Number of sensor ID properties.
properties[propertyCount]	Property	100	List of sensor ID properties.

Property

Field	Type	Description
nameLength	8u	Length of the name.
name[nameLength]	char	Name string.
valueLength	8u	Length of the value.
value[valueLength]	char	Value string.

Control Commands

A client sends control commands for most operations over the Control TCP channel (port 3190).

The Control channel and the Upgrade channel (port 3192) can be connected simultaneously. For more information on Upgrade commands, see *Upgrade Commands* on page 385.

States

A sensor system can be in one of three states: Conflict, Ready, or Running. The client sends the [Start](#) and [Stop](#) control commands to change the system's current state to Running and Ready, respectively. The

sensor can also be configured to boot in either the Ready or Running state, by enabling or disabling autostart, respectively, using the [Set Auto Start Enabled](#) command.

In the Ready state, a sensor can be configured. In the Running state, a sensor responds to input signals, performs measurements, drives its outputs, and sends data messages to the client.

The state of the sensor can be retrieved using the [Get States](#) or [Get System Info](#) command.

The Conflict state indicates that a sensor has been configured with a Buddy sensor but the Buddy sensor is not present on the network. The sensor will not accept some commands until the [Set Buddy](#) command is used to remove the configured Buddy.

Progressive Reply

Some commands send replies progressively, as multiple messages. This allows the sensor to stream data without buffering it first, and allows the client to obtain progress information on the stream.

A progressive reply begins with an initial, standard reply message. If the *status* field of the reply indicates success, the reply is followed by a series of “continue” reply messages.

A continue reply message contains a block of data of variable size, as well as status and progress information. The series of continue messages is ended by either an error, or a continue message containing 0 bytes of data.

Protocol Version

The Protocol Version command returns the protocol version of the connected sensor.

Command

Field	Type	Offset	Description
length	32u	0	Command size including this field, in bytes.
id	16u	4	Command identifier (0x4511)

Reply

Field	Type	Offset	Description
length	32u	0	Reply size including this field, in bytes.
id	16u	4	Reply identifier (0x4511).
status	32s	6	Reply status. For a list of status codes, see <i>Commands</i> on page 344.
majorVersion	8u	10	Major version.
minorVersion	8u	11	Minor version.

Get Address

The Get Address command is used to get a sensor address.

Command

Field	Type	Offset	Description
length	32u	0	Command size including this field, in bytes.
id	16u	4	Command identifier (0x3012)

Reply

Field	Type	Offset	Description
length	32u	0	Reply size including this field, in bytes.
id	16u	4	Reply identifier (0x3012).
status	32s	6	Reply status. For a list of status codes, see <i>Commands</i> on page 344.
dhcpEnabled	byte	10	0 – DHCP not used 1 – DHCP used
address[4]	byte	11	IP address (most significant byte first).
subnetMask[4]	byte	15	Subnet mask.
gateway[4]	byte	19	Gateway address.

Set Address

The Set Address command modifies the network configuration of a sensor. On receiving the command, the sensor will perform a reset. You should wait 30 seconds before re-connecting to the sensor.

Command

Field	Type	Offset	Description
length	32u	0	Command size including this field, in bytes.
id	16u	4	Command identifier (0x3013)
dhcpEnabled	byte	6	0 – DHCP not used 1 – DHCP used
address[4]	byte	7	IP address (most significant byte first).
subnetMask[4]	byte	11	Subnet mask.
gateway[4]	byte	15	Gateway address.

Reply

Field	Type	Offset	Description
length	32u	0	Reply size including this field, in bytes.
id	16u	4	Reply identifier (0x3013).
status	32s	6	Reply status. For a list of status codes, see <i>Commands</i> on page 344.

Get System Info V2

The Get System Info command reports information about the local node, remote nodes and assigned buddies.

Firmware version refers to the version of the sensor's firmware installed on each individual sensor. The client can upgrade the sensor's firmware by sending the Start Upgrade command (see *Start Upgrade* on page 385). Firmware upgrade files are available from the downloads section under the support tab on the LMI web site. For more information on getting the latest firmware, see *Firmware Upgrade* on page 86.

Every sensor contains factory backup firmware. If a firmware upgrade command fails (e.g., power is interrupted), the factory backup firmware will be loaded when the sensor is reset or power cycled. In this case, the sensors will fall back to the factory default IP address. To avoid IP address conflicts in a multi-sensor system, connect to one sensor at a time and re-attempt the firmware upgrade.

Command

Field	Type	Offset	Description
length	32u	0	Command size including this field, in bytes.
id	16u	4	Command identifier (0x4010)

Reply

Field	Type	Offset	Description
length	32u	0	Reply size including this field, in bytes.
id	16u	4	Reply identifier (0x4010).
status	32s	6	Reply status. For a list of status codes, see <i>Commands</i> on page 344.
localInfoSize	16u	10	Size of localInfo structure. Current: 116.
localInfo	Local Info	12	Info for this device.
remoteCount	32u	-	Number of discovered sensors.
remoteInfoSize	16u	-	Size of remoteInfo structure. Current 124.
remoteInfo[remoteCount]	Remote Info	-	List of info for discovered sensors.
buddyInfoCount	32u	-	Number of buddies assigned (can be 0).
buddyInfoSize	16u	-	Size of buddyInfo structure. Current: 8.
Buddies[buddyCount]	Buddy Info	-	List of info for the assigned buddies.

Local Info

Field	Type	Offset	Description
deviceId	32u	0	Serial number of the device.
address[4]	byte	4	IP address (most significant byte first).
modelName[32]	char	8	Model name; "part number" starting with GoSdk 5.3.17.23. Should not be parsed.
firmwareVersion[4]	byte	40	Firmware version (most significant byte first).
state	32s	44	Sensor state -1 – Conflict 0 – Ready 1 – Running For more information on states, see <i>Control Commands</i> on page 347.
role	32s	48	Sensor role 0 – Main 1 – Buddy

Field	Type	Offset	Description
modelNumber[32]	char	52	Model number that can be parsed.
modelDisplayName[32]	char	84	User-friendly model display name that can be used to rename sensors more appropriately for custom-branding naming.

Remote Info

Field	Type	Offset	Description
deviceId	32u	0	Serial number of the remote device.
address[4]	byte	4	IP address (most significant byte first).
modelName[32]	char	8	Remote model name; "remote part number" starting with GoSdk 5.3.17.23.
firmwareVersion[4]	byte	40	Remote firmware version (most significant byte first).
state	32s	44	Remote sensor state -1 - Conflict 0 - Ready 1 - Running For more information on states, see <i>Control Commands</i> on page 347.
role	32s	48	Sensor role 0 - Main 1 - Buddy
mainId	32u	52	Serial number of the main device, or zero.
buddiableStatus	32s	56	Whether or not the device can be buddied: 1 - Can be buddied Errors: 0 - Unbuddiable (General Error) -100 - Already buddied -99 - Invalid State (e.g. running) -98 - Version Mismatch -97 - Model Mismatch
modelNumber[32]	char	60	Model number that can be parsed.
modelDisplayName[32]	char	92	Remote user-friendly model display name that can be used to rename sensors more appropriately for custom-branding naming.

Buddy Info

Field	Type	Offset	Description
deviceld	32u	2	Serial number of the device.
state	k32s	6	Buddy state 2 - Connecting 1 - Connected Errors: 0 - Unbuddiable (General Error) -100 - Already buddied -99 - Invalid State (e.g. running) -98 - Version Mismatch -97 - Model Mismatch -95 - Device Missing -92 - Standalone Sensor -91 - Restricted Sensor Mismatch

Get System Info

 This version of the Get System Info command is deprecated. Use [Get System Info \(v2\)](#) instead.

The Get System Info command reports information for sensors that are visible in the system.

Firmware version refers to the version of the sensor's firmware installed on each individual sensor. The client can upgrade the sensor's firmware by sending the Start Upgrade command (see *Start Upgrade* on page 385). Firmware upgrade files are available from the downloads section under the support tab on the LMI web site. For more information on getting the latest firmware, see *Firmware Upgrade* on page 86.

Every sensor contains factory backup firmware. If a firmware upgrade command fails (e.g., power is interrupted), the factory backup firmware will be loaded when the sensor is reset or power cycled. In this case, the sensors will fall back to the factory default IP address. To avoid IP address conflicts in a multi-sensor system, connect to one sensor at a time and re-attempt the firmware upgrade.

Command

Field	Type	Offset	Description
length	32u	0	Command size including this field, in bytes.
id	16u	4	Command identifier (0x4002)

Reply

Field	Type	Offset	Description
length	32u	0	Reply size including this field, in bytes.
id	16u	4	Reply identifier (0x4002).
status	32s	6	Reply status. For a list of status codes, see <i>Commands</i> on

Field	Type	Offset	Description
			page 344.
localInfo	Sensor Info	10	Info for this device.
remoteCount	32u	66	Number of discovered sensors.
remoteInfo[remoteCount]	Sensor Info	70	List of info for discovered sensors.

Sensor Info

Field	Type	Offset	Description
deviceId	32u	0	Serial number of the device.
address[4]	byte	4	IP address (most significant byte first).
modelName[32]	char	8	Model name.
firmwareVersion[4]	byte	40	Firmware version (most significant byte first).
state	32s	44	Sensor state -1 – Conflict 0 – Ready 1 – Running For more information on states, see <i>Control Commands</i> on page 347.
role	32s	48	Sensor role 0 – Main 1 – Buddy
buddyId	32s	52	Serial number of paired device (main or buddy). 0 if unpaired.

Get States

The Get States command returns various system states.

Command

Field	Type	Offset	Description
length	32u	0	Command size including this field, in bytes.
id	16u	4	Command identifier (0x4525)

Reply

Field	Type	Offset	Description
length	32u	0	Reply size including this field, in bytes.
id	16u	4	Reply identifier (0x4525).
status	32s	6	Reply status. For a list of status codes, see <i>Commands</i> on page 344.
count	32u	10	Number of state variables.
sensorState	32s	14	Sensor state

Field	Type	Offset	Description
			-1 – Conflict 0 – Ready 1 – Running For more information on states, see <i>Control Commands</i> on page 347.
loginState	32s	18	Device login state 0 – No user 1 – Administrator 2 – Technician
alignmentReference	32s	22	Alignment reference 0 – Fixed 1 – Dynamic
alignmentState	32s	26	Alignment state 0 – Unaligned 1 – Aligned
recordingEnabled	32s	30	Whether or not recording is enabled 0 – Disabled 1 – Enabled
playbackSource	32s	34	Playback source 0 – Live data 1 – Recorded data
uptimeSec	32su	38	Uptime (whole seconds component)
uptimeMicrosec	32u	42	Uptime (remaining microseconds component)
playbackPos	32u	46	Playback position
playbackCount	32u	50	Playback frame count
autoStartEnabled	32u	54	Auto-start enable (boolean)
isAccelerator	32u	58	Is the device an accelerator instance?
voltage	32u	62	Voltage setting 0 – 48V 1 – 24V
cableLength	32u	66	Cable length (maximum is 60.0 meters, default is 5.0 meters)
quickEditEnabled	32u	70	Quick Edit state
securityLevel	32s	74	Security Level 0 – No security, any user type can access system. 1 – Basic security level, only authorized user types can access system.

Field	Type	Offset	Description
brandingType	32s	78	Branding Type 0 – None/Gocator (default) 1 – White Label 2 – Custom

Log In/Out

The Log In/Out command is used to log in or out of a sensor.

Command

Field	Type	Offset	Description
length	32u	0	Command size including this field, in bytes.
id	16u	4	Command identifier (0x4003).
userType	32s	6	Defines the user type 0 – None (log out) 1 – Administrator 2 – Technician
password[64]	char	10	Password (required for log-in only).

Reply

Field	Type	Offset	Description
length	32u	0	Reply size including this field, in bytes.
id	16u	4	Reply identifier (0x4003).
status	32s	6	Reply status. For a list of status codes, see <i>Commands</i> on page 344.

Change Password

The Change Password command is used to change log-in credentials for a user.

Command

Field	Type	Offset	Description
length	32u	0	Command size including this field, in bytes.
id	16u	4	Command identifier (0x4004).
user type	32s	6	Defines the user type 0 – None (log out) 1 – Administrator 2 – Technician
password[64]	char	10	New password.

Reply

Field	Type	Offset	Description
length	32u	0	Reply size including this field, in bytes.
id	16u	4	Reply identifier (0x4004).
status	32s	6	Reply status. For a list of status codes, see <i>Commands</i> on page 344.



Passwords can only be changed if a user is logged in as an administrator.

Assign Buddies

The Assign Buddies command is used to set the list of buddies assigned to the system.

This command can be used to both add and remove buddies by changing the list of buddies. A serial number of 0 can be used to add device slots that are not assigned a physical sensor. Collections associated with the devices (e.g. <Device> element in the configuration) grow or shrink accordingly. Items are added to or removed from the end of these collections. For example: the system starts with 2 devices, [A, B]. A new list [A, B, C] is sent. The configuration for A and B are preserved, and a new record is created for C. If now the system changes back to [A, B], the record for C is deleted. Adding or removing items in the middle of the list has the same behaviour. Example: the system starts with 3 devices, [A, B, C]. A new list [A, C] is sent. The configuration for B is now used for C, and the configuration for C is deleted. To ensure consistency when adding and removing devices, add only to the end of the list and remove using the Remove Buddies command.

Command

Field	Type	Offset	Description
length	32u	0	Command size including this field, in bytes.
id	16u	4	Command identifier (0x4011).
buddyCount	32u	6	Number of buddies or 0 to unbuddy all devices.
buddies[buddyCount]	32u	10	Serial Numbers of the buddies to assign (can be 0).

Reply

Field	Type	Offset	Description
length	32u	0	Reply size including this field, in bytes.
id	16u	4	Reply identifier (0x4011).
status	32s	6	Reply status. For a list of status codes, see <i>Commands</i> on page 344.

Remove Buddies

The Remove Buddies command is used to remove one or more buddies using 0-based buddy indices.

Use this command to remove a buddy devices along with its associated configuration resources. If the system starts with 3 devices: [A, B, C], and this command is called to remove B, the configuration items for A and C remain unchanged.

Command

Field	Type	Offset	Description
length	32u	0	Command size including this field, in bytes.
id	16u	4	Command identifier (0x4013).
buddyCount	32u	6	Number of buddies.
buddyIds[buddyCount]	32u	10	Indices of the buddies to remove. Note that the first buddy has index 0 (i.e. it's the index of buddies, not all devices including the main).

Reply

Field	Type	Offset	Description
length	32u	0	Reply size including this field, in bytes.
id	16u	4	Reply identifier (0x4013).
status	32s	6	Reply status. For a list of status codes, see <i>Commands</i> on page 344.

Set Buddy

The Set Buddy command is used to assign or unassign a Buddy sensor.

Command

Field	Type	Offset	Description
length	32u	0	Command size including this field, in bytes.
id	16u	4	Command identifier (0x4005).
buddyId	32u	6	Id of the sensor to acquire as buddy. Set to 0 to remove buddy.

Reply

Field	Type	Offset	Description
length	32u	0	Reply size including this field, in bytes.
id	16u	4	Reply identifier (0x4005).
status	32s	6	Reply status. For a list of status codes, see <i>Commands</i> on page 344.

List Files

The List Files command returns a list of the files in the sensor's file system.

Command

Field	Type	Offset	Description
length	32u	0	Command size including this field, in bytes.
id	16u	4	Command identifier (0x101A).
extension[64]	char	6	Specifies the extension used to filter the list of files (does not include the "."). If an empty string is used, then no filtering is performed.

Reply

Field	Type	Offset	Description
length	32u	0	Reply size including this field, in bytes.
id	16u	4	Reply identifier (0x101A).
status	32s	6	Reply status. For a list of status codes, see <i>Commands</i> on page 344.
count	32u	10	Number of file names.
fileNames[count][64]	char	14	File names.

Copy File

The Copy File command copies a file from a source to a destination within the connected sensor (a .job file, a component of a job file, or another type of file; for more information, see *Job File Structure* on page 273).

To make a job active (to load it), copy a saved job to "_live.job".

To "save" the active job, copy from "_live.job" to another file.

Command

Field	Type	Offset	Description
length	32u	0	Command size including this field, in bytes.
id	16u	4	Command identifier (0x101B).
source[64]	char	6	Source file name.
destination[64]	char	70	Destination file name.

Reply

Field	Type	Offset	Description
length	32u	0	Reply size including this field, in bytes.
id	16u	4	Reply identifier (0x101B).
status	32s	6	Reply status. For a list of status codes, see <i>Commands</i> on page 344.

Read File

Downloads a file from the connected sensor (a .job file, a component of a job file, or another type of file; for more information, see *Job File Structure* on page 273).

To download the live configuration, pass "_live.job" in the *name* field.

To read the configuration of the live configuration only, pass "_live.job/config.xml" in the *name* field.

Command

Field	Type	Offset	Description
length	32u	0	Command size including this field, in bytes.
id	16u	4	Command identifier (0x1007).
name[64]	char	6	Source file name.

Reply

Field	Type	Offset	Description
length	32u	0	Reply size including this field, in bytes.
id	16u	4	Reply identifier (0x1007).
status	32s	6	Reply status. For a list of status codes, see <i>Commands</i> on page 344.
length	32u	10	File length.
data[length]	byte	14	File contents.

Write File

The Write File command uploads a file to the connected sensor (a .job file, a component of a job file, or another type of file; for more information, see *Job File Structure* on page 273).

To make a job file live, write to "_live.job". Except for writing to the live file, the file is permanently stored on the sensor.

Command

Field	Type	Offset	Description
length	32u	0	Command size including this field, in bytes.
id	16u	4	Command identifier (0x1006).
name[64]	char	6	Source file name.
length	32u	70	File length.
data[length]	byte	74	File contents.

Reply

Field	Type	Offset	Description
length	32u	0	Reply size including this field, in bytes.
id	16u	4	Reply identifier (0x1006).
status	32s	6	Reply status. For a list of status codes, see <i>Commands</i> on page 344.

Delete File

The Delete File command removes a file from the connected sensor (a .job file, a component of a job file, or another type of file; for more information, see *Job File Structure* on page 273).

Command

Field	Type	Offset	Description
length	32u	0	Command size including this field, in bytes.
id	16u	4	Command identifier (0x1008).
name[64]	char	6	Source file name.

Reply

Field	Type	Offset	Description
length	32u	0	Reply size including this field, in bytes.
id	16u	4	Reply identifier (0x1008).
status	32s	6	Reply status. For a list of status codes, see <i>Commands</i> on page 344.

User Storage Used

The User Storage Used command returns the amount of user storage that is used.

Command

Field	Type	Offset	Description
length	32u	0	Command size including this field, in bytes.
id	16u	4	Command identifier (0x1021).

Reply

Field	Type	Offset	Description
length	32u	0	Reply size including this field, in bytes.
id	16u	4	Reply identifier (0x1021).
status	32s	6	Reply status.
spaceUsed	64u	10	The used storage space in bytes.

User Storage Free

The User Storage Free command returns the amount of user storage that is free.

Command

Field	Type	Offset	Description
length	32u	0	Command size including this field, in bytes.
id	16u	4	Command identifier (0x1022).

Reply

Field	Type	Offset	Description
length	32u	0	Reply size including this field, in bytes.
id	16u	4	Reply identifier (0x1022).
status	32s	6	Reply status.
spaceFree	64u	10	The free storage space in bytes.

Get Default Job

The Get Default Job command gets the name of the job the sensor loads when it powers up.

Command

Field	Type	Offset	Description
length	32u	0	Command size including this field, in bytes.
id	16u	4	Command identifier (0x4100).

Reply

Field	Type	Offset	Description
length	32u	0	Reply size including this field, in bytes.
id	16u	4	Reply identifier (0x4100).
status	32s	6	Reply status. For a list of status codes, see <i>Commands</i> on page 344.
name[64]	char	10	The file name (null-terminated) of the job the sensor loads when it powers up.

Set Default Job

The Set Default Job command sets the job the sensor loads when it powers up.

Command

Field	Type	Offset	Description
length	32u	0	Command size including this field, in bytes.
id	16u	4	Command identifier (0x4101).
fileName[64]	char	6	File name (null-terminated) of the job the sensor loads when it powers up.

Reply

Field	Type	Offset	Description
length	32u	0	Reply size including this field, in bytes.
id	16u	4	Reply identifier (0x4101).
status	32s	6	Reply status. For a list of status codes, see <i>Commands</i> on page 344.

Get Loaded Job

The Get Loaded Job command returns the name and modified status of the currently loaded file.

Command

Field	Type	Offset	Description
length	32u	0	Command size including this field, in bytes.
id	16u	4	Command identifier (0x4512).

Reply

Field	Type	Offset	Description
length	32u	0	Reply size including this field, in bytes.

Field	Type	Offset	Description
id	16u	4	Reply identifier (0x4512).
status	32s	6	Reply status. For a list of status codes, see <i>Commands</i> on page 344.
fileName[64]	char	10	Name of the currently loaded job.
changed	8u	74	Whether or not the currently loaded job has been changed (1: yes; 0: no).

Get Alignment Reference

The Get Alignment Reference command is used to get the sensor's alignment reference.

Command

Field	Type	Offset	Description
length	32u	0	Command size including this field, in bytes.
id	16u	4	Command identifier (0x4104).

Reply

Field	Type	Offset	Description
length	32u	0	Reply size including this field, in bytes.
id	16u	4	Reply identifier (0x4104).
status	32s	6	Reply status. For a list of status codes, see <i>Commands</i> on page 344.
reference	32s	10	Alignment reference 0 – Fixed 1 – Dynamic

Set Alignment Reference

The Set Alignment Reference command is used to set the sensor's alignment reference.

Command

Field	Type	Offset	Description
length	32u	0	Command size including this field, in bytes.
id	16u	4	Command identifier (0x4103).
reference	32s	6	Alignment reference 0 – Fixed 1 – Dynamic

Reply

Field	Type	Offset	Description
length	32u	0	Reply size including this field, in bytes.
id	16u	4	Reply identifier (0x4103).

Field	Type	Offset	Description
status	32s	6	Reply status. For a list of status codes, see <i>Commands</i> on page 344.

Clear Alignment

The Clear Alignment command clears sensor alignment.

Command

Field	Type	Offset	Description
length	32u	0	Command size including this field, in bytes.
id	16u	4	Command identifier (0x4102).

Reply

Field	Type	Offset	Description
length	32u	0	Reply size including this field, in bytes.
id	16u	4	Reply identifier (0x4102).
status	32s	6	Reply status. For a list of status codes, see <i>Commands</i> on page 344.

Get Timestamp

The Get Timestamp command retrieves the sensor's timestamp, in clock ticks. All devices in a system are synchronized with the system clock; this value can be used for diagnostic purposes, or used to synchronize the start time of the system.

Command

Field	Type	Offset	Description
length	32u	0	Command size including this field, in bytes.
id	16u	4	Command identifier (0x100A).

Reply

Field	Type	Offset	Description
length	32u	0	Reply size including this field, in bytes.
id	16u	4	Reply identifier (0x100A).
status	32s	6	Reply status. For a list of status codes, see <i>Commands</i> on page 344.
timestamp	64u	10	Timestamp, in clock ticks.

Get Encoder

This command retrieves the current system encoder value.

Command

Field	Type	Offset	Description
length	32u	0	Command size including this field, in bytes.
id	16u	4	Command identifier (0x101C).

Reply

Field	Type	Offset	Description
length	32u	0	Reply size including this field, in bytes.
id	16u	4	Reply identifier (0x101C).
status	32s	6	Reply status. For a list of status codes, see <i>Commands</i> on page 344.
encoder	64s	10	Current encoder position, in ticks.

Reset Encoder

The Reset Encoder command is used to reset the current encoder value.

 The encoder value can be reset only when the encoder is connected directly to a sensor. When the encoder is connected to the master, the value cannot be reset via this command.

Command

Field	Type	Offset	Description
length	32u	0	Command size including this field, in bytes.
id	16u	4	Command identifier (0x101E).

Reply

Field	Type	Offset	Description
length	32u	0	Reply size including this field, in bytes.
id	16u	4	Reply identifier (0x101E).
status	32s	6	Reply status. For a list of status codes, see <i>Commands</i> on page 344.

Start

The Start command starts the sensor system (system enters the Running state). For more information on states, see *Control Commands* on page 347.

Command

Field	Type	Offset	Description
length	32u	0	Command size including this field, in bytes.
id	16u	4	Command identifier (0x100D).

Reply

Field	Type	Offset	Description
length	32u	0	Reply size including this field, in bytes.
id	16u	4	Reply identifier (0x100D).
status	32s	6	Reply status. For a list of status codes, see <i>Commands</i> on page 344.

Scheduled Start

The scheduled start command starts the sensor system (system enters the Running state) at target time or encoder value (depending on the trigger mode). For more information on states, see *Control Commands* on page 347.

Command

Field	Type	Offset	Description
length	32u	0	Command size – in bytes.
id	16u	4	Command identifier (0x100F).
target	64s	6	Target scheduled start value (in ticks or μ s, depending on the trigger type).

Reply

Field	Type	Offset	Description
length	32u	0	Reply size – in bytes.
id	16u	4	Reply identifier (0x100F).
status	32s	6	Reply status. For a list of status codes, see <i>Commands</i> on page 344.

Stop

The Stop command stops the sensor system (system enters the Ready state). For more information on states, see *Control Commands* on page 347.

Command

Field	Type	Type	Description
length	32u	0	Command size including this field, in bytes.
id	16u	4	Command identifier (0x1001).

Reply

Field	Type	Offset	Description
length	32u	0	Reply size including this field, in bytes.
id	16u	4	Reply identifier (0x1001).
status	32s	6	Reply status. For a list of status codes, see <i>Commands</i> on page 344.

Get Auto Start Enabled

The Get Auto Start Enabled command returns whether the system automatically starts after booting.

Command

Field	Type	Offset	Description
length	32u	0	Command size including this field, in bytes.
id	16u	4	Command identifier (0x452C).

Reply

Field	Type	Offset	Description
length	32u	0	Reply size including this field, in bytes.
id	16u	4	Reply identifier (0x452C).
status	32s	6	Reply status. For a list of status codes, see <i>Commands</i> on page 344.
enable	8u	10	0: disabled 1: enabled

Set Auto Start Enabled

The Set Auto Start Enabled command sets whether the system automatically starts after booting (enters Running state; for more information on states, see *Control Commands* on page 347).

Command

Field	Type	Offset	Description
length	32u	0	Command size including this field, in bytes.
id	16u	4	Command identifier (0x452B).
enable	8u	6	0: disabled 1: enabled

Reply

Field	Type	Offset	Description
length	32u	0	Reply size including this field, in bytes.
id	16u	4	Reply identifier (0x452B).
status	32s	6	Reply status. For a list of status codes, see <i>Commands</i> on page 344.

Get Voltage Settings

The Get Voltage Settings command returns the sensor's voltage and cable length settings.

Command

Field	Type	Offset	Description
length	32u	0	Command size including this field, in bytes.
id	16u	4	Command identifier (0x4539).

Reply

Field	Type	Offset	Description
length	32u	0	Reply size including this field, in bytes.
id	16u	4	Reply identifier (0x4539).
Voltage	16u	10	0: 48 Volts; 1: 24 Volts.
Cable Length	32u	12	0 – 100: Meters

Set Voltage Settings

The Set Voltage Settings command sets the sensor's voltage and cable length settings.

Command

Field	Type	Offset	Description
length	32u	0	Command size including this field, in bytes.
id	16u	4	Command identifier (0x4538).
Voltage	16u	6	0: 48 Volts; 1: 24 Volts.
Cable Length	32u	8	0 – 100: Meters

Reply

Field	Type	Offset	Description
length	32u	0	Reply size including this field, in bytes.
id	16u	4	Reply identifier (0x4538).
status	32s	6	Reply status. For a list of status codes, see <i>Commands</i> on page 344.

Get Quick Edit Enabled

The Get Quick Edit Enabled command returns whether Quick Edit mode is enabled on the sensor.

Command

Field	Type	Offset	Description
length	32u	0	Command size including this field, in bytes.
id	16u	4	Command identifier (0x4541).

Reply

Field	Type	Offset	Description
length	32u	0	Reply size including this field, in bytes.
id	16u	4	Reply identifier (0x4541).
status	32s	6	Reply status. For a list of status codes, see <i>Commands</i> on page 344.
Enable	8u	10	0: disabled; 1: enabled.

Set Quick Edit Enabled

The Set Quick Edit Enabled command enables or disables Quick Edit mode on the sensor.

Command

Field	Type	Offset	Description
length	32u	0	Command size including this field, in bytes.
id	16u	4	Command identifier (0x4540).
enable	8u	6	0: disabled; 1: enabled.

Reply

Field	Type	Offset	Description
length	32u	0	Reply size including this field, in bytes.
id	16u	4	Reply identifier (0x4540).
status	32s	6	Reply status. For a list of status codes, see <i>Commands</i> on page 344.

Start Alignment

The Start Alignment command is used to start the alignment procedure on a sensor.

Command

Field	Type	Offset	Description
length	32u	0	Command size including this field, in bytes.
id	16u	4	Command identifier (0x4600).

Reply

Field	Type	Offset	Description
length	32u	0	Reply size including this field, in bytes.
id	16u	4	Reply identifier (0x4600).
status	32s	6	Reply status. For a list of status codes, see <i>Commands</i> on page 344.
opId	32u	10	Operation ID. Use this ID to correlate the command/reply on the Command channel with the correct Alignment Result message on the Data channel. A unique ID is returned each time the client uses this command.

Start Exposure Auto-set

The Start Exposure Auto-set command is used to start the exposure auto-set procedure on a sensor.

Command

Field	Type	Offset	Description
length	32u	0	Command size including this field, in bytes.
id	16u	4	Command identifier (0x4601).
role	32s	6	Role of sensors to auto-set. 0 – Main 1 – Buddy

Reply

Field	Type	Offset	Description
length	32u	0	Reply size including this field, in bytes.
id	16u	4	Reply identifier (0x4601).
status	32s	6	Reply status. For a list of status codes, see <i>Commands</i> on

Field	Type	Offset	Description
			page 344.
opId	32u	10	Operation ID. Use this ID to correlate the command/reply on the Command channel with the correct Exposure Calibration Result message on the Data channel. A unique ID is returned each time the client uses this command.

Software Trigger

The Software Trigger command causes the sensor to take a snapshot while in software mode and in the Running state.

Command

Field	Type	Offset	Description
length	32u	0	Command size including this field, in bytes.
id	16u	4	Command identifier (0x4510).

Reply

Field	Type	Offset	Description
length	32u	0	Reply size including this field, in bytes.
id	16u	4	Reply identifier (0x4510).
status	32s	6	Reply status. For a list of status codes, see <i>Commands</i> on page 344.

Schedule Digital Output

The Schedule Digital Output command schedules a digital output event. The digital output must be configured to accept software-scheduled commands and be in the Running state.

Command

Field	Type	Offset	Description
length	32u	0	Command size including this field, in bytes.
id	16u	4	Command identifier (0x4518).
index	16u	6	Index of the output (starts from 0).
target	64s	8	Specifies the time (clock ticks) when or position (μm) at which the digital output event should happen. The target value is ignored if ScheduleEnabled is set to false. (Scheduled is unchecked in Digital in the Output panel.) The output will be triggered immediately.
value	8u	16	Specifies the target state: 0 – Set to low (continuous) 1 – Set to high (continuous) Ignored if output type is pulsed.

Reply

Field	Type	Offset	Description
length	32u	0	Reply size including this field, in bytes.
id	16u	4	Reply identifier (0x4518).
status	32s	6	Reply status. For a list of status codes, see <i>Commands</i> on page 344.

Schedule Analog Output

The Schedule Analog Output command schedules an analog output event. The analog output must be configured to accept software-scheduled commands and be in the Running state.

Command

Field	Type	Offset	Description
length	32u	0	Command size including this field, in bytes.
id	16u	4	Command identifier (0x4519).
index	16u	6	Index of the output. Must be 0.
target	64s	8	Specifies the time (clock ticks) or position (encoder ticks) of when the event should happen. The target value is ignored if ScheduleEnabled is set to false. (Scheduled is unchecked in Analog in the Output panel.) The output will be triggered immediately.
value	32s	16	Output current (microamperes).

Reply

Field	Type	Offset	Description
length	32u	0	Reply size including this field, in bytes.
id	16u	4	Reply identifier (0x4519).
status	32s	6	Reply status. For a list of status codes, see <i>Commands</i> on page 344.



The analog output takes about 75 us to reach 90% of the target value for a maximum change, then roughly another 40 us to settle completely.

Ping

The Ping command can be used to test the control connection. This command has no effect on sensors.

Command

Field	Type	Offset	Description
length	32u	0	Command size including this field, in bytes.
id	16u	4	Command identifier (0x100E).
timeout	64u	6	Timeout value (microseconds).

Reply

Field	Type	Offset	Description
length	32u	0	Reply size including this field, in bytes.
id	16u	4	Reply identifier (0x100E).
status	32s	6	Reply status. For a list of status codes, see <i>Commands</i> on page 344.



If a non-zero value is specified for timeout, the client must send another ping command before the timeout elapses; otherwise the server would close the connection. The timer is reset and updated with every command.

Reset

The Reset command reboots the Main sensor and any Buddy sensors. All sensors will automatically reset 3 seconds after the reply to this command is transmitted.

Command

Field	Type	Offset	Description
length	32u	0	Command size including this field, in bytes.
id	16u	4	Command identifier (0x4300).

Reply

Field	Type	Offset	Description
length	32u	0	Reply size including this field, in bytes.
id	16u	4	Reply identifier (0x4300).
status	32s	6	Reply status. For a list of status codes, see <i>Commands</i> on page 344.

Backup

The Backup command creates a backup of all files stored on the connected sensor and downloads the backup to the client.

Command

Field	Type	Offset	Description
length	32u	0	Command size including this field, in bytes.
id	16u	4	Command identifier (0x1013).

Reply

Field	Type	Offset	Description
length	32u	0	Reply size including this field, in bytes.
id	16u	4	Reply identifier (0x1013).
status	32s	6	Reply status. For a list of status codes, see <i>Commands</i> on page 344.
length	32u	10	Data length.
data[length]	byte	14	Data content.

Restore

The Restore command uploads a backup file to the connected sensor and then restores all sensor files from the backup.

 The sensor must be reset or power-cycled before the restore operation can be completed.

Command

Field	Type	Offset	Description
length	32u	0	Command size including this field, in bytes.
id	16u	4	Command identifier (0x1014).
length	32u	6	Data length.
data[length]	byte	10	Data content.

Reply

Field	Type	Offset	Description
length	32u	0	Reply size including this field, in bytes.
id	16u	4	Reply identifier (0x1014).
status	32s	6	Reply status. For a list of status codes, see <i>Commands</i> on page 344.

Restore Factory

The Restore Factory command restores the connected sensor to factory default settings.

 The command erases the non-volatile memory of the main device.

This command has no effect on connected Buddy sensors.

Note that the sensor must be reset or power-cycled before the factory restore operation can be completed.

Command

Field	Type	Offset	Description
length	32u	0	Command size including this field, in bytes.
id	16u	4	Command identifier (0x4301).
resetIp	8u	6	Specifies whether IP address should be restored to default: 0 – Do not reset IP 1 – Reset IP

Reply

Field	Type	Offset	Description
length	32u	0	Reply size including this field, in bytes.
id	16u	4	Reply identifier (0x4301).
status	32s	6	Reply status. For a list of status codes, see <i>Commands</i> on page 344.

Get Recording Enabled

The Get Recording Enabled command retrieves whether recording is enabled.

Command

Field	Type	Offset	Description
length	32u	0	Command size including this field, in bytes.
id	16u	4	Command identifier (0x4517).

Reply

Field	Type	Offset	Description
length	32u	0	Reply size including this field, in bytes.
id	16u	4	Reply identifier (0x4517).
status	32s	6	Reply status. For a list of status codes, see <i>Commands</i> on page 344.
enable	8u	10	0: disabled; 1: enabled.

Set Recording Enabled

The Set Recording Enabled command enables recording for replay later.

Command

Field	Type	Offset	Description
length	32u	0	Command size including this field, in bytes.
id	16u	4	Command identifier (0x4516).
enable	8u	6	0: disabled; 1: enabled.

Reply

Field	Type	Offset	Description
length	32u	0	Reply size including this field, in bytes.
id	16u	4	Reply identifier (0x4516).
status	32s	6	Reply status. For a list of status codes, see <i>Commands</i> on page 344.

Clear Replay Data

The Clear Replay Data command clears the sensors replay data..

Command

Field	Type	Offset	Description
length	32u	0	Command size including this field, in bytes.
id	16u	4	Command identifier (0x4513).

Reply

Field	Type	Offset	Description
length	32u	0	Reply size including this field, in bytes.

Field	Type	Offset	Description
id	16u	4	Reply identifier (0x4513).
status	32s	6	Reply status. For a list of status codes, see <i>Commands</i> on page 344.

Get Playback Source

The Get Playback Source command gets the data source for data playback.

Command

Field	Type	Offset	Description
length	32u	0	Command size including this field, in bytes.
id	16u	4	Command identifier (0x4524).

Reply

Field	Type	Offset	Description
length	32u	0	Reply size including this field, in bytes.
id	16u	4	Reply identifier (0x4524).
status	32s	6	Reply status. For a list of status codes, see <i>Commands</i> on page 344.
source	32s	10	Source 0 – Live 1 – Replay buffer

Set Playback Source

The Set Playback Source command sets the data source for data playback.

Command

Field	Type	Offset	Description
length	32u	0	Command size including this field, in bytes.
id	16u	4	Command identifier (0x4523).
source	32s	6	Source 0 – Live 1 – Replay buffer

Reply

Field	Type	Offset	Description
length	32u	0	Reply size including this field, in bytes.
id	16u	4	Reply identifier (0x4523).
status	32s	6	Reply status. For a list of status codes, see <i>Commands</i> on page 344.

Simulate

The Simulate command simulates the last frame if playback source is live, or the current frame if playback source is the replay buffer.

Command

Field	Type	Offset	Description
length	32u	0	Command size including this field, in bytes.
id	16u	4	Command identifier (0x4522).

Reply

Field	Type	Offset	Description
length	32u	0	Reply size including this field, in bytes.
id	16u	4	Reply identifier (0x4522).
status	32s	6	Reply status. For a list of status codes, see <i>Commands</i> on page 344.
bufferValid	8u	10	Whether or not the buffer is valid.

	<p>A reply status of -996 means that the current configuration (mode, sensor type, etc.) does not support simulation.</p> <p>A reply status of -992 means that the simulation buffer is empty. Note that the buffer can be valid even if the simulation buffer is actually empty due to optimization choices. This scenario means that the simulation buffer would be valid if data were recorded.</p>
---	--

Seek Playback

The Seek Playback command seeks to any position in the current playback dataset. The frame is then sent.

Command

Field	Type	Offset	Description
length	32u	0	Command size including this field, in bytes.
id	16u	4	Command identifier (0x4503).
frame	32u	6	Frame index.

Reply

Field	Type	Offset	Description
length	32u	0	Reply size including this field, in bytes.
id	16u	4	Reply identifier (0x4503).
status	32s	6	Reply status. For a list of status codes, see <i>Commands</i> on page 344.

Step Playback

The Step Playback command advances playback by one frame.

Command

Field	Type	Offset	Description
length	32u	0	Command size including this field, in bytes.
id	16u	4	Command identifier (0x4501).
direction	32s	6	Define step direction 0 – Forward 1 – Reverse

Reply

Field	Type	Offset	Description
length	32u	0	Reply size including this field, in bytes.
id	16u	4	Reply identifier (0x4501).
status	32s	6	Reply status. For a list of status codes, see <i>Commands</i> on page 344.



When the system is running in the Replay mode, this command advances replay data (playback) by one frame. This command returns an error if no live playback data set is loaded. You can use the [Copy File](#) command to load a replay data set to `_live.rec`.

Playback Position

The Playback Position command retrieves the current playback position.

Command

Field	Type	Offset	Description
length	32u	0	Command size including this field, in bytes.
id	16u	4	Command identifier (0x4502).

Reply

Field	Type	Offset	Description
length	32u	0	Reply size including this field, in bytes.
id	16u	4	Reply identifier (0x4502).
status	32s	6	Reply status. For a list of status codes, see <i>Commands</i> on page 344.
Frame Index	32u	10	Current frame index (starts from 0).
Frame Count	32u	14	Total number of available frames/objects.

Clear Measurement Stats

The Clear Measurement Stats command clears the sensor's measurement statistics.

Command

Field	Type	Offset	Description
length	32u	0	Command size including this field, in bytes.
id	16u	4	Command identifier (0x4526).

Reply

Field	Type	Offset	Description
length	32u	0	Reply size including this field, in bytes.
id	16u	4	Reply identifier (0x4526).
status	32s	6	Reply status. For a list of status codes, see <i>Commands</i> on page 344.

Read Live Log

The Read Live Log command returns an XML file containing the log messages between the passed start and end indexes.

Command

Field	Type	Offset	Description
length	32u	0	Command size including this field, in bytes.
id	16u	4	Command identifier (0x101F).
Start	32u	6	First log to read
End	32u	10	Last log to read

Reply

Field	Type	Offset	Description
length	32u	0	Reply size including this field, in bytes.
id	16u	4	Reply identifier (0x101F).
status	32s	6	Reply status.
length	32u	10	File length
data[length]	byte	14	XML Log File

Clear Log

The Clear Log command clears the sensor's log.

Command

Field	Type	Offset	Description
length	32u	0	Command size including this field, in bytes.
id	16u	4	Command identifier (0x101D).

Reply

Field	Type	Offset	Description
length	32u	0	Reply size including this field, in bytes.
id	16u	4	Reply identifier (0x101D).
status	32s	6	Reply status. For a list of status codes, see <i>Commands</i> on page 344.

Simulate Unaligned

The Simulate Unaligned command simulates data before alignment transformation.

Command

Field	Type	Offset	Description
length	32u	0	Command size including this field, in bytes.
id	16u	4	Command identifier (0x452A).

Reply

Field	Type	Offset	Description
length	32u	0	Reply size including this field, in bytes.
id	16u	4	Reply identifier (0x452A).
status	32s	6	Reply status. For a list of status codes, see <i>Commands</i> on page 344.

Acquire

The Acquire command acquires a new scan.

Command

Field	Type	Offset	Description
length	32u	0	Command size including this field, in bytes.
id	16u	4	Command identifier (0x4528).

Reply

Field	Type	Offset	Description
length	32u	0	Reply size including this field, in bytes.
id	16u	4	Reply identifier (0x4528).
status	32s	6	Reply status. For a list of status codes, see <i>Commands</i> on page 344.



The command returns after the scan has been captured and transmitted.

Acquire Unaligned

The Acquire Unaligned command acquires a new scan without performing alignment transformation.

Command

Field	Type	Offset	Description
length	32u	0	Command size including this field, in bytes.
id	16u	4	Command identifier (0x4527).

Reply

Field	Type	Offset	Description
length	32u	0	Reply size including this field, in bytes.
id	16u	4	Reply identifier (0x4527).
status	32s	6	Reply status. For a list of status codes, see <i>Commands</i> on page 344.



The command returns after the scan has been captured and transmitted.

Create Model

The Create Model command creates a new part model from the active simulation scan.

Command

Field	Type	Offset	Description
length	32u	0	Command size including this field, in bytes.
id	16u	4	Command identifier (0x4602).
modelName[64]	char	6	Name of the new model (without .mdl extension)

Reply

Field	Type	Offset	Description
length	32u	0	Reply size including this field, in bytes.
id	16u	4	Reply identifier (0x4602).
status	32s	6	Reply status. For a list of status codes, see <i>Commands</i> on page 344.

Detect Edges

The Detect Edges command detects and updates the edge points of a part model.

Command

Field	Type	Offset	Description
length	32u	0	Command size including this field, in bytes.
id	16u	4	Command identifier (0x4604).
modelName[64]	char	6	Name of the model (without .mdl extension)
sensitivity	16u	70	Sensitivity (in thousandths).

Reply

Field	Type	Offset	Description
length	32u	0	Reply size including this field, in bytes.
id	16u	4	Reply identifier (0x4604).
status	32s	6	Reply status. For a list of status codes, see <i>Commands</i> on page 344.

Add Tool

The Add Tool command adds a tool to the live job.

Command

Field	Type	Offset	Description
length	32u	0	Command size including this field, in bytes.
id	16u	4	Command identifier (0x4530).

Field	Type	Offset	Description
typeName[64]	char	6	Type name of the tool (e.g., ProfilePosition)
name[64]	char	70	User-specified name for tool instance

Reply

Field	Type	Offset	Description
length	32u	0	Reply size including this field, in bytes.
id	16u	4	Reply identifier (0x4530).
status	32s	6	Reply status. For a list of status codes, see <i>Commands</i> on page 344.

Add Measurement

The Add Measurement command adds a measurement to a tool instance.

Command

Field	Type	Offset	Description
length	32u	0	Command size including this field, in bytes.
id	16u	4	Command identifier (0x4531).
toolIndex	32u	6	Index of the tool instance the new measurement is added to.
typeName[64]	char	10	Type name of the measurement (for example, X).
name[64]	char	74	User-specified name of the measurement instance.

Reply

Field	Type	Offset	Description
length	32u	0	Reply size including this field, in bytes.
id	16u	4	Reply identifier (0x4531).
status	32s	6	Reply status. For a list of status codes, see <i>Commands</i> on page 344.

 This command can only be used with dynamic tools (tools with a dynamic list of measurements). The maximum number of instances for a given measurement type can be found in the [ToolOptions](#) node. For dynamic tools, the maximum count is greater than one, while for static tools it is one.

Read File (Progressive)

The progressive Read File command reads the content of a file as a stream.

This command returns an initial reply, followed by a series of "continue" replies if the initial reply's *status* field indicates success. The continue replies contain the actual data, and have 0x5000 as their identifier.

Command

Field	Type	Offset	Description
length	32u	0	Command size including this field, in bytes.

Field	Type	Offset	Description
id	16u	4	Command identifier (0x4529).
name[64]	char	6	Source file name.

Initial Reply

Field	Type	Offset	Description
length	32u	0	Reply size including this field, in bytes.
id	16u	4	Reply identifier (0x4529).
status	32s	6	Reply status. For a list of status codes, see <i>Commands</i> on page 344.
progressTotal	32u	10	Progress indicating completion (100%).
progress	32u	14	Current progress.

Continue Reply

Field	Type	Offset	Description
length	32u	0	Reply size including this field, in bytes.
id	16u	4	Reply identifier (0x5000).
status	32s	6	Reply status. For a list of status codes, see <i>Commands</i> on page 344.
progressTotal	32u	10	Progress indicating completion (100%).
progress	32u	14	Current progress.
size	32u	18	Size of the chunk in bytes.
data[size]	byte	22	Chunk data.

Export CSV (Progressive)

The progressive Export CSV command exports replay data as a CSV stream.

This command returns an initial reply, followed by a series of "continue" replies if the initial reply's *status* field indicates success. The continue replies contain the actual data, and have 0x5000 as their identifier.

Command

Field	Type	Offset	Description
length	32u	0	Command size including this field, in bytes.
id	16u	4	Command identifier (0x4507).

Initial Reply

Field	Type	Offset	Description
length	32u	0	Reply size including this field, in bytes.
id	16u	4	Reply identifier (0x4507).
status	32s	6	Reply status. For a list of status codes, see <i>Commands</i> on page 344.

Field	Type	Offset	Description
progressTotal	32u	10	Progress indicating completion (100%).
progress	32u	14	Current progress.

Continue Reply

Field	Type	Offset	Description
length	32u	0	Reply size including this field, in bytes.
id	16u	4	Reply identifier (0x5000).
status	32s	6	Reply status. For a list of status codes, see <i>Commands</i> on page 344.
progressTotal	32u	10	Progress indicating completion (100%).
progress	32u	14	Current progress.
size	32u	18	Size of the chunk in bytes.
data[size]	byte	22	Chunk data.

 All recorded range or profile data is exported to the CSV stream.

Export Bitmap (Progressive)

The progressive Export Bitmap command exports replay data as a bitmap stream.

This command returns an initial reply, followed by a series of "continue" replies if the initial reply's *status* field indicates success. The continue replies contain the actual data, and have 0x5000 as their identifier.

Command

Field	Type	Offset	Description
length	32u	0	Command size including this field, in bytes.
id	16u	4	Command identifier (0x4508).
type	32s	6	Data type: 0 – Range or video 1 – Intensity
source	32s	10	Data source to export.

Initial Reply

Field	Type	Offset	Description
length	32u	0	Reply size including this field, in bytes.
id	16u	4	Reply identifier (0x4508).
status	32s	6	Reply status. For a list of status codes, see <i>Commands</i> on page 344.
progressTotal	32u	10	Progress indicating completion (100%).
progress	32u	14	Current progress.

Continue Reply

Field	Type	Offset	Description
length	32u	0	Reply size including this field, in bytes.
id	16u	4	Reply identifier (0x5000).
status	32s	6	Reply status. For a list of status codes, see <i>Commands</i> on page 344.
progressTotal	32u	10	Progress indicating completion (100%).
progress	32u	14	Current progress.
size	32u	18	Size of the chunk in bytes.
data[size]	byte	22	Chunk data.

Get Flag

The Get Flag command returns the given flag value as a string.

Command

Field	Type	Offset	Description
length	32u	0	Command size including this field, in bytes.
id	16u	4	Command identifier (0x4533).
name[256]	Char	6	A string representing the flag name whose value is to be retrieved.

Reply

Field	Type	Offset	Description
length	32u	0	Reply size including this field, in bytes.
id	16u	4	Reply identifier (0x4533).
valueLength	32u	10	The length of the string representing the flag's value.
value[valueLength]	Char	14	The value of the flag.

Set Flag

The Set Flag command sets the string value for the given flag name.

Command

Field	Type	Offset	Description
length	32u	0	Command size including this field, in bytes.
id	16u	4	Command identifier (0x4534).
Variablename[256]	Char	6	A string representing the flag name whose value is to be retrieved.
valueLength	32u	262	The length of the flag's value string.
value[valueLength]	Char	266	The string representing the flag's value.

Reply

Field	Type	Offset	Description
length	32u	0	Reply size including this field, in bytes.
id	16u	4	Reply identifier (0x4534).
status	32s	6	Reply status. For a list of status codes, see <i>Commands</i> on page 344.

Get Runtime Variable Count

The Get Runtime Variable Count command gets the number of runtime variables that can be accessed.

Command

Field	Type	Offset	Description
length	32u	0	Command size including this field, in bytes.
id	16u	4	Command identifier (0x4537).

Reply

Field	Type	Offset	Description
length	32u	0	Reply size including this field, in bytes.
id	16u	4	Reply identifier (0x4537).
status	32s	6	Reply status.
valueLength	32u	10	The count of runtime variables.

Set Runtime Variables

The Set Runtime Variables command sets the runtime variables at the given index for the given length.

Command

Field	Type	Offset	Description
length	32u	0	Command size including this field, in bytes.
id	16u	4	Command identifier (0x4536).
index	32u	6	The starting index of the variables to set.
length	32u	10	The number of values to set from the starting index.
values[length]	32s	14	The runtime variable values to set.

Reply

Field	Type	Offset	Description
length	32u	0	Reply size including this field, in bytes.
id	16u	4	Reply identifier (0x4536).
status	32s	6	Reply status.

Get Runtime Variables

The Get Runtime Variables command gets the runtime variables for the given index and length.

Command

Field	Type	Offset	Description
length	32u	0	Command size including this field, in bytes.
id	16u	4	Command identifier (0x4535).
index	32u	6	The starting index of the variables to retrieve.
length	32u	10	The number of values to retrieve from the starting index.

Reply

Field	Type	Offset	Description
length	32u	0	Reply size including this field, in bytes.
id	16u	4	Reply identifier (0x4535).
status	32s	6	Reply status.
index	32u	10	The starting index of the variables being returned.
length	32u	14	The number of values being returned.
values[length]	32s	18	The runtime variable values.

Upgrade Commands

A client sends firmware upgrade commands over the Upgrade TCP channel (port 3192).

The Control channel (port 3190) and the Upgrade channel can be connected simultaneously. For more information on Control commands, see *Control Commands* on page 347.

After connecting to a sensor, you can use the [Protocol Version](#) command to retrieve the protocol version. Protocol version refers to the version of the Gocator Protocol supported by the *connected sensor* (the sensor to which a command connection is established), and consists of major and minor parts. The minor part is updated when backward-compatible additions are made to the protocol. The major part is updated when breaking changes are made to the protocol.

Start Upgrade

The Start Upgrade command begins a firmware upgrade for the sensors in a system. All sensors automatically reset 3 seconds after the upgrade process is complete.

Command

Field	Type	Offset	Description
length	64s	0	Command size including this field, in bytes.
id	64s	8	Command identifier (0x0000).
length	64s	16	Length of the upgrade package (bytes).
data[length]	byte	24	Upgrade package data.

Reply

Field	Type	Offset	Description
length	64s	0	Reply size including this field, in bytes.
id	64s	8	Reply identifier (0x0000).

Field	Type	Offset	Description
status	64s	16	Reply status. For a list of status codes, see <i>Commands</i> on page 344.

Start Upgrade Extended

The Start Upgrade Extended command begins a firmware upgrade for the sensors in a system. All sensors automatically reset 3 seconds after the upgrade process is complete.

Command

Field	Type	Offset	Description
length	64s	0	Command size including this field, in bytes.
id	64s	8	Command identifier (0x0003).
skipValidation	64s	16	Whether or not to skip validation (0 – do not skip, 1 – skip).
length	64s	24	Length of the upgrade package (bytes).
data[length]	byte	32	Upgrade package data.

Reply

Field	Type	Offset	Description
length	64s	0	Reply size including this field, in bytes.
id	64s	8	Reply identifier (0x0003).
status	64s	16	Reply status. For a list of status codes, see <i>Commands</i> on page 344.

Get Upgrade Status

The Get Upgrade Status command determines the progress of a firmware upgrade.

Command

Field	Type	Offset	Description
length	64s	0	Command size including this field, in bytes.
id	64s	8	Command identifier (0x1)

Reply

Field	Type	Offset	Description
length	64s	0	Reply size including this field, in bytes.
id	64s	8	Reply identifier (0x1).
status	64s	16	Reply status. For a list of status codes, see <i>Commands</i> on page 344.
state	64s	24	Upgrade state: -1 – Failed 0 – Completed 1 – Running 2 – Completed, but should run again

Field	Type	Offset	Description
progress	64s	32	Upgrade progress (valid when in the Running state)

Get Upgrade Log

The Get Upgrade Log command can retrieve an upgrade log in the event of upgrade problems.

Command

Field	Type	Offset	Description
length	64s	0	Command size including this field, in bytes.
id	64s	8	Command identifier (0x2)

Reply

Field	Type	Offset	Description
length	64s	0	Reply size including this field, in bytes.
id	64s	8	Reply identifier (0x2).
status	64s	16	Reply status. For a list of status codes, see <i>Commands</i> on page 344.
length	64s	24	Length of the log (bytes).
log[length]	char	32	Log content.

Results

The following sections describe the results (data and health) that a sensor sends.

Data Results

A client can receive data messages from a sensor by connecting to the Data TCP channel (port 3196).

The Data channel and the Health channel (port 3194) can be connected at the same time. The sensor accepts multiple connections on each port. For more information on the Health channel, see *Health Results* on page 396.

Messages that are received on the Data and Health channels use a common structure, called Gocator Data Protocol (GDP). Each message consists of a 6-byte header, containing *size* and *control* fields, followed by a variable-length, message-specific content section. The structure of the GDP message is defined below.

Gocator Data Protocol

Field	Type	Offset	Description
size	32u	0	Count of bytes in message (including this field).
control	16u	4	Bit 15: Last Message flag Bits 0-14: Message type identifier. (See individual data result sections.)

Messages are always sent in groups. The Last Message flag in the *control* field is used to indicate the final message in a group. If there is only one message per group, this bit will be set in each message.

Stamp

Field	Type	Offset	Description
size	32u	0	Count of bytes in message (including this field).
control	16u	4	Bit 15: Last message flag. Bits 0-14: Message type identifier. For this message, set to 1.
count (C)	32u	6	Count of stamps in this message.
size	16u	10	Stamp size, in bytes (min: 56, current: 56).
source	8u	12	Source (0 – Main, 1 – Buddy).
reserved	8u	13	Reserved.
stamps[C]	Stamp	14	Array of stamps (see below).

Stamp

Field	Type	Offset	Description
frameIndex	64u	0	Frame index (counts up from zero).
timestamp	64u	8	Timestamp (μ s).
encoder	64s	16	Current encoder value (ticks).
encoderAtZ	64s	24	Encoder value latched at z/index mark (ticks).
status	64u	32	Bit field containing various frame information: Bit 0: sensor digital input state Bit 4: master digital input state Bit 8-9: inter-frame digital pulse trigger. (Master digital input if master is connected, otherwise sensor digital input. Value is cleared after each frame and clamped at 3 if more than 3 pulses are received).
serialNumber	32u	40	Sensor serial number. (In a dual-sensor system, the serial number of the main sensor.)
reserved[2]	32u	44	Reserved.

Video

Field	Type	Offset	Description
size	32u	0	Count of bytes in message (including this field).
control	16u	4	Bit 15: Last message flag. Bits 0-14: Message type identifier. For this message, set to 2.
attributesSize	16u	6	Size of attributes, in bytes (min: 20, current: 20).
height (H)	32u	8	Image height, in pixels.
width (W)	32u	12	Image width, in pixels.
pixelSize	8u	16	Pixel size, in bytes.
pixelFormat	8u	17	Pixel format:

Field	Type	Offset	Description
			1 – 8-bit greyscale 2 – 8-bit color filter 3 – 8-bits-per-channel color (B, G, R, X)
colorFilter	8u	18	Color filter array alignment: 0 – None 1 – Bayer BG/GR 2 – Bayer GB/RG 3 – Bayer RG/GB 4 – Bayer GR/BG
source	8u	19	Source 0 – Top 1 – Bottom 2 – Top Left 3 – Top Right
cameraIndex	8u	20	Camera index.
exposureIndex	8u	21	Exposure index.
exposure	32u	22	Exposure (ns).
flippedX	8u	26	Indicates whether the video data must be flipped horizontally to match up with profile data.
flippedY	8u	27	Indicates whether the video data must be flipped vertically to match up with profile data.
streamStep	32s	28	Data stream step number. For video, values are: 0 – video stream step 8 – tool data stream step
streamStepId	32s	32	Data stream step identifier within the stream step.
pixels[H][W]	(Variable)	36	Image pixels. (Depends on pixelSize above.)

Range

Field	Type	Offset	Description
size	32u	0	Count of bytes in message (including this field).
control	16u	4	Bit 15: Last message flag. Bits 0-14: Message type identifier. For this message, set to 3.
attributeSize	16u	6	Size of attributes, in bytes (min: 20, current: 20).
count (C)	32u	8	Number of profile arrays.
zScale	32u	12	Z scale (nm).
zOffset	32s	16	Z offset (µm).

Field	Type	Offset	Description
source	8u	20	Source 0 – Top 1 – Bottom 2 – Top Left 3 – Top Right
exposure	32u	21	Exposure (ns).
reserved[3]	8u	25	Reserved.
streamStep	32s	28	Data stream step number. For range, values are: 1 – range stream step 8 – tool data stream step
streamStepId	32s	32	Data stream step identifier within the stream step.
range[C]	16s	36	Range values.

Range Intensity

Field	Type	Offset	Description
size	32u	0	Count of bytes in message (including this field).
control	16u	4	Bit 15: Last message flag. Bits 0-14: Message type identifier. For this message, set to 4.
attributeSize	16u	6	Size of attributes, in bytes (min: 12, current: 12).
count (C)	32u	8	Number of profile arrays.
source	8u	12	Source 0 – Top 1 – Bottom 2 – Top Left 3 – Top Right
exposure	32u	13	Exposure (ns).
reserved[3]	8u	17	Reserved.
streamStep	32s	28	Data stream step number. For range, values are: 1 – range stream step 8 – tool data stream step
streamStepId	32s	32	Data stream step identifier within the stream step.
range[C]	8u	28	Range intensity values.

Profile Point Cloud

Field	Type	Offset	Description
size	32u	0	Count of bytes in message (including this field).
control	16u	4	Bit 15: Last message flag. Bits 0-14: Message type identifier. For this message, set to 5.
attributeSize	16u	6	Size of attributes, in bytes (min: 32, current: 32).
count (C)	32u	8	Number of profile arrays.
width (W)	32u	12	Number of points per profile array.
xScale	32u	16	X scale (nm).
zScale	32u	20	Z scale (nm).
xOffset	32s	24	X offset (μm).
zOffset	32s	28	Z offset (μm).
Source	8u	32	Source 0 – Top 1 – Bottom 2 – Top Left 3 – Top Right
exposure	32u	33	Exposure (ns).
cameraIndex	8u	37	Camera index.
reserved[2]	8u	38	Reserved.
streamStep	32s	40	Stream step
streamStepId	32s	44	Data stream step identifier within the stream step.
ranges[C][W]	Point16s	48	Profile ranges.

Profile Intensity

Field	Type	Offset	Description
size	32u	0	Count of bytes in message (including this field).
control	16u	4	Bit 15: Last message flag. Bits 0-14: Message type identifier. For this message, set to 7.
attributesSize	16u	6	Size of attributes, in bytes (min: 24, current: 24).
count (C)	32u	8	Number of profile intensity arrays.
width (W)	32u	12	Number of points per profile intensity array.
xScale	32u	16	X scale (nm).
xOffset	32s	20	X offset (μm).
source	8u	24	Source 0 – Top

Field	Type	Offset	Description
			1 – Bottom 2 – Top Left 3 – Top Right
exposure	32u	25	Exposure (ns).
cameraIndex	8u	29	Camera index.
reserved[2]	8u	30	Reserved.
streamStep	32s	32	Data stream step number. For video, values are: 2 – profile stream step 8 – tool data stream step
streamStepId	32s	36	Data stream step identifier within the stream step.
points[C][W]	8u	40	Intensity arrays.

Measurement

Field	Type	Offset	Description
size	32u	0	Count of bytes in message (including this field).
control	16u	4	Bit 15: Last message flag. Bits 0-14: Message type identifier. For this message, set to 10.
count (C)	32u	6	Count of measurements in this message.
reserved[2]	8u	10	Reserved.
id	16u	12	Measurement identifier.
measurements[C]	Measurement	14	Array of measurements (see below).

Measurement

Field	Type	Offset	Description
value	32s	0	Measurement value.
decision	8u	4	Measurement decision bitmask. Bit 0: 1 – Pass 0 – Fail Bits 1-7: 0 – Measurement value OK 1 – Invalid value 2 – Invalid anchor
reserved[3]	8u	5	Reserved.

Alignment Result

Field	Type	Offset	Description
size	32u	0	Count of bytes in message (including this field).
control	16u	4	Bit 15: Last message flag. Bits 0-14: Message type identifier. For this message, set to 11.
attributesSize	16u	6	Size of attributes, in bytes (min: 8, current: 8).
opId	32u	8	Operation ID.
status	32s	12	Operation status. 1 – OK 0 – General failure -1 – No data in the field of view for stationary alignment -2 – No profiles with sufficient data for line fitting for travel alignment -3 – Invalid target detected. Examples include: - Calibration disk diameter too small. - Calibration disk touches both sides of the field of view. - Too few valid data points after outlier rejection. -4 – Target detected in an unexpected position. -5 – No reference hole detected in bar alignment. -6 – No change in encoder value during travel calibration -988 – User aborted -993 – Timed out -997 – Invalid parameter

Exposure Calibration Result

Field	Type	Offset	Description
size	32u	0	Count of bytes in message (including this field).
control	16u	4	Bit 15: Last message flag. Bits 0-14: Message type identifier. For this message, set to 12.
attributesSize	16u	6	Size of attributes, in bytes (min: 8, current: 8).
opId	32u	8	Operation ID.
status	32s	12	Operation status.
exposure	32u	16	Exposure result (ns).

Event

Field	Type	Offset	Description
size	32u	0	Count of bytes in message (including this field).
control	16u	4	Bit 15: Last message flag. Bits 0-14: Message type identifier. For this message, set to 22.
attributesSize	16u	6	Size of attributes, in bytes (min: 8, current: 8).
eventType	32u	8	The type of event: 0 – Exposure Begin 1 – Exposure End
length	32u	12	The number of bytes containing additional data.
data[length]	8u	16	Additional data.

Feature Point

Field	Type	Offset	Description
size	32u	0	Count of bytes in message (including this field).
control	16u	4	Bit 15: Last message flag. Bits 0-14: Message type identifier. For this message, set to 24.
id	16u	6	Feature Id
Point.x	64s	8	X Coordinate of Point (Scaled by 10 ⁶)
Point.y	64s	16	Y Coordinate of Point (Scaled by 10 ⁶)
Point.z	64s	24	Z Coordinate of Point (Scaled by 10 ⁶)

Feature Line

Field	Type	Offset	Description
size	32u	0	Count of bytes in message (including this field).
control	16u	4	Bit 15: Last message flag. Bits 0-14: Message type identifier. For this message, set to 25.
id	16u	6	Feature Id
Point.x	64s	8	X Coordinate of Point (Scaled by 10 ⁶)
Point.y	64s	16	Y Coordinate of Point (Scaled by 10 ⁶)
Point.z	64s	24	Z Coordinate of Point (Scaled by 10 ⁶)
Direction.x	64s	32	X Component of Direction Vector (Scaled by 10 ⁶)
Direction.y	64s	40	Y Component of Direction Vector (Scaled by 10 ⁶)
Direction.z	64s	48	Z Component of Direction Vector (Scaled by 10 ⁶)

Feature Plane

Field	Type	Offset	Description
size	32u	0	Count of bytes in message (including this field).
control	16u	4	Bit 15: Last message flag. Bits 0-14: Message type identifier. For this message, set to 26.
id	16u	6	Feature Id
Normal.x	64s	8	X Component of Normal Vector (Scaled by 10 ⁶)
Normal.y	64s	16	Y Component of Normal Vector (Scaled by 10 ⁶)
Normal.z	64s	24	Z Component of Normal Vector (Scaled by 10 ⁶)
originDistance	64s	32	Distance to Origin (Scaled by 10 ⁶)

Feature Circle

Field	Type	Offset	Description
size	32u	0	Count of bytes in message (including this field).
control	16u	4	Bit 15: Last message flag. Bits 0-14: Message type identifier. For this message, set to 27.
id	16u	6	Feature Id
Point.x	64s	8	X Coordinate of Point (Scaled by 10 ⁶)
Point.y	64s	16	Y Coordinate of Point (Scaled by 10 ⁶)
Point.z	64s	24	Z Coordinate of Point (Scaled by 10 ⁶)
Normal.x	64s	32	X Component of Normal Vector (Scaled by 10 ⁶)
Normal.y	64s	40	Y Component of Normal Vector (Scaled by 10 ⁶)
Normal.z	64s	48	Z Component of Normal Vector (Scaled by 10 ⁶)
radius	64s	56	Radius of Circle (Scaled by 10 ⁶)

Generic Message

Field	Type	Offset	Description
size	32u	0	Count of bytes in message (including this field).
control	16u	4	Bit 15: Last message flag. Bits 0-14: Message type identifier. For this message, set to 29.
attributeSize	16u	6	Size of attributes, in bytes (min: 32, current: 40).
streamStep	32s	8	Data stream step.
streamStepId	32s	12	Data stream step ID.
userType	32u	16	User-define data type ID
isObject	8u	20	0 – Content is raw byte buffer 1 – Content is an kObject

Field	Type	Offset	Description
contentLength	32u	21	Length of content array, in bytes
Content[contentLength]	byte	25	Content array. If isObject is true, the byte buffer should be deserialized using kDat6Serializer.

Health Results

A client can receive health messages from a sensor by connecting to the Health TCP channel (port 3194).

The Data channel (port 3196) and the Health channel can be connected at the same time. The sensor accepts multiple connections on each port. For more information on the Data channel, see *Data Results* on page 387.

Messages that are received on the Data and Health channels use a common structure, called Gocator Data Protocol (GDP). Each message consists of a 6-byte header, containing *size* and *control* fields, followed by a variable-length, message-specific content section. The structure of the GDP message is defined below.

Gocator Data Protocol

Field	Type	Offset	Description
size	32u	0	Count of bytes in message (including this field).
control	16u	4	Bit 15: Last Message flag Bits 0-14: Message type identifier. (See individual data result sections.)

Messages are always sent in groups. The Last Message flag in the *control* field is used to indicate the final message in a group. If there is only one message per group, this bit will be set in each message.

A Health Result contains a single data block for health *indicators*. Each indicator reports the current status of some aspect of the sensor system, such as CPU usage or network throughput.

Health Result

Field	Type	Offset	Description
size	32u	0	Count of bytes in message (including this field).
control	16u	4	Bit 15: Last message flag. Bits 0-14: Message type identifier. Always 0.
count (C)	32u	6	Count of indicators in this message.
source	8u	10	Source (0 – Main, 1 – Buddy).
reserved[3]	8u	11	Reserved
indicators[C]	Indicator	14	Array of indicators (see format below).

The indicators block contains a 2-dimensional array of indicator data. Each row in the array has the following format:

Indicator Format

Field	Type	Offset	Description
id	32u	0	Unique indicator identifier (see <i>Indicator identifiers</i> below table below).
instance	32u	4	Indicator instance.
value	64s	8	Value (identifier-specific meaning).

The following health indicators are defined for sensor systems.

 When a sensor is accelerated, some health indicators report values from the *PC* that is accelerating the sensor, or a combination of both. In the table below, values are reported from the sensor unless otherwise indicated.

 Undocumented indicators may be included in addition to the indicators defined below.

Indicator identifiers

Indicator	ID	Instance	Value
Encoder Value	1003	-	Current system encoder tick.
Encoder Frequency	1005	-	Current system encoder frequency (ticks/s).
Laser Safety	1010	-	Laser safety status. 0: laser is disabled 1: laser is enabled
App Version	2000	-	Firmware application version.
Internal Temperature	2002	-	Internal temperature (centidegrees Celsius).
Uptime	2017	-	Time elapsed since node boot-up or reset (seconds).
Projector Temperature	2404	-	Projector module temperature (centidegrees Celsius). Only available on projector based devices.
Control Temperature	2028	-	Control module temperature (centidegrees Celsius). Available only on 3B-class devices.
Memory Usage	2003	-	Amount of memory currently used (bytes).
Memory Capacity	2004	-	Total amount of memory available (bytes).
Storage Usage	2005	-	Amount of non-volatile storage used (bytes).
Storage Capacity	2006	-	Total amount of non-volatile storage available (bytes).
Alignment State	20008	-	Alignment state: 0 – not aligned 1 - aligned

Indicator	ID	Instance	Value
CPU Usage	2007	-	CPU usage (percentage of maximum).
Net Out Capacity	2009	-	Total available outbound network throughput (bytes/s).
Net Out Link Status	2034	-	Current Ethernet link status.
Sync Source*	2043	-	Synchronization source. 1 - Master device 2 - Sensor
Digital Inputs*	2024	-	Current digital input status (one bit per input).
Event Count	2102	-	Total number of events triggered.
Camera Search Count	2217	-	Number of search states. (Only important when tracking is enabled.)
Camera Trigger Drops	2201	-	Number of dropped triggers.
Analog Output Drops	21014 (previously 2501)	Output Index	Number of dropped outputs.
Digital Output Drops	21015 (previously 2601)	Output Index	Number of dropped outputs.
Serial Output Drops	21016 (previously 2701)	Output Index	Number of dropped outputs.
Sensor State*	20000	-	Sensor state. -1 – Conflict 0 – Ready 1 – Running
Current Sensor Speed*	20001	-	Current sensor speed. (Hz)
Maximum Speed*	20002	-	The sensor's maximum speed.
Spot Count*	20003	-	Number of spots found in the last unresampled profile/surface.
Max Spot Count*	20004	-	Maximum number of spots that can be found.
Scan Count*	20005	-	Number of surfaces detected from a top device.
Master Status*	20006	0 for main 1 for buddy	Master connection status: 0 – Not connected 1 – Connected The indicator with instance = buddy does not exist if the buddy is not connected.
Cast Start State*	20007		The state of the second digital input. (NOTE: Only available on XLine capable licensed devices)

Indicator	ID	Instance	Value
Point Count	20015	-	Number of points found in last resampled Profile/Surface.
Max Point Count	20016	-	Maximum number of points that can be found.
Laser Overheat*	20020	-	Indicates whether laser overheat has occurred. 0 – Has not overheated 1 – Has overheated Only available on certain 3B laser devices.
Laser Overheat Duration*	20021	-	The length of time in which the laser overheating state occurred. Only available on certain 3B laser devices.
Playback Position*	20023	-	The current replay playback position.
Playback Count*	20024	-	The number of frames present in the replay.
FireSync Version	20600	-	The FireSync version used by the Gocator build. The low-level firmware version used by the sensor.
Processing Drops**	21000	-	Number of dropped frames. The sum of various processing drop related indicators.
Last Processing Latency	21001	-	Last delay from camera exposure to availability of all results.
Max Processing Latency	21002	-	Maximum value of processing latency.
Ethernet Output	21003	-	Number of bytes transmitted.
Ethernet Rate	21004	-	The average number of bytes per second being transmitted.
Ethernet Drops	21005	-	Number of dropped Ethernet packets.
Trigger Drops**	21010	-	Number of dropped triggers. The sum of various triggering-related drop indicators.
Output Drops**	21011	-	Number of dropped output data. The sum of all output drops (analog, digital, serial, host server, and ASCII server).
Controlled Trigger Drops	21017	-	Trigger drops from the Controlled Triggering System (Grouped with “Trigger Drops” indicator)
Surface Processing Time	21018	-	Processing Time of Frame on 35XX/32XX (microseconds)
Max Frame Rate	21019	-	Max Configurable frame rate given above Processing Time (scaled by 1x10 ⁻⁶)
Range Valid Count**	21100	-	Number of valid ranges.
Range Invalid Count**	21101	-	Number of invalid ranges.
Anchor Invalid Count**	21200	-	Number of frames with anchoring invalid.

Indicator	ID	Instance	Value
Light Operational Time	21201	-	Total running time of G2 laser or G3 projector light (on Gocator firmware 5.3 or later), in minutes.
First Log Id	21301		ID of the first available log entry.
Last Log Id	21300		ID of the last available log entry. It is inclusive: for example, if first = 3 and last = 5, the available log IDs are 3, 4, 5. If no log is available, the last ID is less than the first ID.
Z-Index Drop Count	22000	-	The number of dropped surfaces due to a lack of z-encoder pulse during rotational part detection.
Tool Run Time	22004	Tool Index	The most recent time taken to execute the tool.
Part Total Emitted	22006	-	Total number of parts emitted by profile part detection.
Part Length Limit	22007	-	Number of parts emitted due to reaching the length limit.
Part Min Area Drops	22008	-	Number of parts dropped due to being smaller than the minimum area.
Part Backtrack Drops	22009	-	Number of parts dropped due to backtracking.
Parts Currently Active	22010	-	Number of parts currently being tracked.
Part Length	22011	-	Length of largest active part.
Part Start Y	22012	-	Start Y position of the largest active part.
Part Tracking State	22013	-	Tracking state of the largest active part.
Part Capacity Exceeded	22014	-	Part detection part or run capacity has been exceeded.
Part X Position	22015	-	Center X position of the largest active part.
Tool Runtime Minimum	22016	-	Minimum time spent for tool to process a sample
Tool Runtime Maximum	22017	-	Maximum time spent for tool to process a sample
Tool Runtime Average	22018	-	Average time for tool to process a sample
Tool Runtime Percent Average	22019	-	Average percentage of total time spent running this tool
Bar Alignment Status	22020	-	Status of the buffered bar alignment when aligning: 1 - buffer leveling in progress 2 - buffer searching in progress 3 - buffer scanning in progress 4 - buffer padding in progress 5 - buffering complete; processing alignment on

Indicator	ID	Instance	Value
			buffered data
			11 – alignment leveling in progress
			12 – alignment searching in progress
			13 – alignment fitting in progress
			14 – alignment complete
			15 – alignment completed but failed
			16 – alignment cancelled
Value	30000	Measurement ID	Measurement Value.
Pass	30001	Measurement ID	Number of pass decision.
Fail	30002	Measurement ID	Number of fail decision.
Min	30003	Measurement ID	Minimum measurement value.
Max	30004	Measurement ID	Maximum measurement value.
Average	30005	Measurement ID	Average measurement value.
Std. Dev.	30006	Measurement ID	Measurement value standard deviation.
Invalid Count	30007	Measurement ID	Number of invalid values.
Overflow	30008	Measurement ID	<p>Number of times this measurement has overflown on any output. Multiple simultaneous overflows result in only a single increment to this counter. Overflow conditions include:</p> <ul style="list-style-type: none"> -Value exceeds bit representation available for given protocol -Analog output (mA) falls outside of acceptable range (0-20 mA) <p>When a measurement value overflow occurs, the value is set to the null value appropriate for the given protocol's measurement value output type. The Overflow health indicator increments.</p>

* When the sensor is accelerated, the indicator's value is reported from the accelerating PC.

** When the sensor is accelerated, the indicator's value is the sum of the values reported from the sensor and the accelerating PC.

Modbus Protocol

Modbus is designed to allow industrial equipment such as Programmable Logic Controllers (PLCs), sensors, and physical input/output devices to communicate over an Ethernet network.

Modbus embeds a Modbus frame into a TCP frame in a simple manner. This is a connection-oriented transaction, and every query expects a response.

This section describes the Modbus TCP commands and data formats. Modbus TCP communication lets the client:

- Switch jobs.
- Align and run sensors.
- Receive measurement results, sensor states, and stamps.

To use the Modbus protocol, it must be enabled and configured in the active job. For information on configuring the protocol using the Web interface, see *Ethernet Output* on page 235.

 The Gocator 4.x/5.x firmware uses mm, mm², mm³, and degrees as standard units. In all protocols, values are scaled by 1000, as values in the protocols are represented as integers. This results in effective units of mm/1000, mm²/1000, mm³/1000, and deg/1000 in the protocols.

If buffering is enabled with the Modbus protocol, the PLC must read the Buffer Advance output register (see *State* on page 405) to advance the queue before reading the measurement results.

Concepts

A PLC sends a command to start each sensor. The PLC then periodically queries each sensor for its latest measurement results. In Modbus terminology, the PLC is a Modbus Client. Each sensor is a Modbus Server which serves the results to the PLC.

The Modbus protocol uses TCP for connection and messaging. The PLC makes a TCP connection to the sensor on port 502. Control and data messages are communicated on this TCP connection. Up to eight clients can be connected to the sensor simultaneously. A connection closes after 10 minutes of inactivity.

Messages

All Modbus TCP messages consist of an MBAP header (Modbus Application Protocol), a function code, and a data payload.

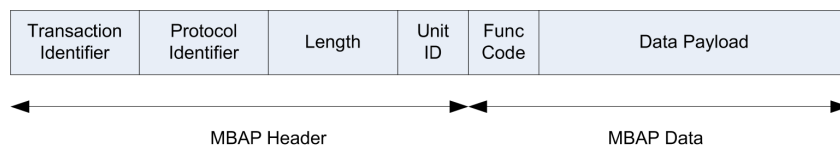

The MBAP header contains the following fields:

Modbus Application Protocol Header

Field	Length (Bytes)	Description
Transaction ID	2	Used for transaction pairing. The Modbus Client sets the value and the Server (the sensor) copies the value into its responses.
Protocol ID	2	Always set to 0.
Length	2	Byte count of the rest of the message, including the Unit identifier and data fields.
Unit ID	1	Used for intra-system routing purpose. The Modbus Client sets the value and the Server (the sensor) copies the value into its responses.

Modbus Application Protocol Specification describes the standard function codes in detail. Gocator supports the following function codes:

Modbus Function Code

Function Code	Name	Data Size (bits)	Description
3	Read Holding Registers	16	Read multiple data values from the sensor.
4	Read Input Registers	16	Read multiple data values from the sensor.
6	Write Single Register	16	Send a command or parameter to the sensor.
16	Write Multiple Registers	16	Send a command and parameters to the sensor.

The data payload contains the registers that can be accessed by Modbus TCP messages. If a message accesses registers that are invalid, a reply with an exception is returned. Modbus Application Protocol Specification defines the exceptions and describes the data payload format for each function code.

The sensor data includes 16-bit, 32-bit, and 64-bit data. All data are sent in big endian format, with the 32-bit and 64-bit data spread out into two and four consecutive registers.

32-bit Data Format

Register	Name	Bit Position
0	32-bit Word 1	31 .. 16
1	32-bit Word 0	15 .. 0

64-bit Data Format

Register	Name	Bit Position
0	64-bit Word 3	63 .. 48
1	64-bit Word 2	47 .. 32
2	64-bit Word 1	31 .. 16
3	64-bit Word 0	15 .. 0

Registers

Modbus registers are 16 bits wide and are either control registers or output registers.

Control registers are used to control the sensor states (e.g., start, stop, or calibrate a sensor).

The output registers report the sensor states, stamps, and measurement values and decisions. You can read multiple output registers using a single Read Holding Registers or a single Read Input Registers command. Likewise, you can control the state of the sensor using a single Write Multiple Register command.

Control registers are write-only, and output registers are read-only.

Register Map Overview

Register Address	Name	Read/Write	Description
0 - 124	Control Registers	WO	Registers for Modbus commands. See <i>Control Registers</i> below for detailed descriptions.
300 - 899	Sensor States	RO	Report sensor states. See <i>State</i> on the next page for detailed descriptions.
900 - 999	Stamps	RO	Return stamps associated with each range. See <i>State</i> on the next page for detailed descriptions.
1000 - 1998	Measurements & Decisions	RO	333 measurement and decision pairs. See <i>Measurement Registers</i> on page 407 for detailed descriptions.

Control Registers

Control registers are used to operate the sensor. Register 0 stores the command to be executed. Subsequent registers contain parameters for the commands if applicable. The sensor executes a command when the value in register 0 is changed. To set the parameters before a command is executed, you should set up the parameters and the command using a single Multiple Write register command.

Control Register Map

Register Address	Name	Read/Write	Description
0	Command Register	WO	Takes a 16-bit command. For a list of the available commands, see table below.
1 - 64	Command Parameters	WO	For Load Job (5) command: Null-terminated filename. Each 16-bit register holds a single character. Specifies the filename. If the file extension ".job" is missing, it is automatically appended to the filename. For Set Runtime Variables (6) command: Registers 1-8 are used to set the values of the runtime variables.

The 16-bit values used for Command Register are described below.

Command Register Values

Value	Name	Description
0	Stop Running	Stops the sensor. No effect if sensor is already stopped.
1	Start Running	Starts the sensor. No effect if sensor is already started.
2	Align (stationary target)	Starts the stationary alignment process. State register 301 will be set to 1 (busy). When the alignment process is complete, the register is set back to zero.
3	Align (moving target)	Starts moving alignment process and also calibrate encoder resolution. State register 301 will be set to 1 (busy). When the alignment process is complete, the register is set back to zero.
4	Clear Alignment	Clears the alignment.
5	Load Job	Activates the specified job file. Set registers 1-64 to the null-terminated filename, one filename character per 16-bit register, including the null terminator character. The ".job" extension is optional; if it is missing, it is automatically appended to the file name.
6	Set Runtime Variables	Sets the runtime variables. Set registers 1 through 8 to the values of all four 32-bit runtime variables.
7	Software trigger	Software trigger the sensor to capture one frame. The sensor must already be running, in trigger mode "Software". Otherwise, software trigger has no effect.

Output Registers

Output registers are used to output states, stamps, and measurement results. Each register address holds a 16-bit data value.

State

State registers report the current sensor state.

State Register Map

Register Address	Name	Type	Description
300	Sensor State	16u	Sensor State: 0 - Stopped 1 - Running
301	Modbus Command in Progress	16u	1 when the sensor is busy performing the last command, 0 when done. Registers 302 and 311-371 below are only valid when there is no command in progress.
302	Alignment State	16u	Current Alignment State: 0 - Not aligned 1- Aligned

Register Address	Name	Type	Description
			(Valid when register 301 = 0.)
303	Encoder Position High	64u	Current encoder position (64-bit value, requiring four 16-bit registers)
304	Encoder		
305	Encoder		
306	Encoder Low		
307	Time High	64s	Uptime timestamp (64-bit value, requiring four 16-bit registers)
308	Time		
309	Time		
310	Time Low		
311	Job File Name Length	16u	Number of characters in the current job file name. (Valid when register 301 = 0.)
312 – 371	Live Job Name	16u	Name of currently loaded job file. Does not include the extension. Each 16-bit register contains a single character. (Valid when register 301 = 0.)
375	Runtime Variable 0 High	32s	Runtime variable value stored in two register locations.
376	Runtime Variable 0 Low		
...
381	Runtime Variable 3 High	32s	Runtime variable value stored in two register locations.
382	Runtime Variable 3 Low		

Stamp

Stamps contain trigger timing information used for synchronizing a PLC's actions. A PLC can also use this information to match up data from multiple sensors.

Stamps are updated after each range data is processed.

Stamp Register Map

Register Address	Name	Type	Description
960-975	reserved		Not used.
976	Buffer Advance Register	16u	If buffering is enabled, this address must be read by the PLC Modbus client first to advance the buffer. After the buffer advance read operation, the Modbus client can read the updated Measurements & Decisions in addresses 1000-1059.
977	Buffer Count	16u	Number of buffered messages currently in the

Register Address	Name	Type	Description
			queue.
978	Buffer Overflow Flag	16u	Buffer Overflow Indicator: 0 - No overflow 1 - Overflow. (Indicates data is being lost.)
979	Inputs	16u	Digital input state of the last frame.
980	zPosition High	64u	Encoder position at time of last index pulse. 64-bit value, requiring four 16-bit registers.
981	zPosition		
982	zPosition		
983	zPosition Low		
984	Exposure High	32u	Laser exposure (μ s) of the last frame. Stored in two register locations.
985	Exposure Low		
986	Temperature High	32u	Sensor temperature in degrees Celcius * 100 (centidegrees) of the last frame. Stored in two register locations.
987	Temperature Low		
988	Encoder Position High	64u	Encoder position of the last frame when the image data was scanned/taken. 64-bit value, requiring four 16-bit registers.
989	Encoder Position		
990	Encoder Position		
991	Encoder Position Low		
992	Time High	64u	Time stamp in microseconds of the last frame. 64-bit value, requiring four 16-bit registers.
993	Time		
994	Time		
995	Time Low		
996	Frame Index High	64u	The frame number of the last frame. 64-bit value, requiring four 16-bit registers.
997	Frame Index		
998	Frame Index		
999	Frame Index Low		

Measurement Registers

Measurement results are reported in pairs of values and decisions. Measurement values are 32 bits wide and decisions are 8 bits wide.

The measurement ID is used to find the register address of each pair. The register address of the first word can be calculated as $(1000 + 3 * ID)$. For example, a measurement with ID set to 4 can be read from registers 1012 (high word) and 1013 (low word), and the decision at 1015.

The measurement results are updated after each range data is processed.

Measurement Register Map

Register Address	Name	Type	Description
1000	Measurement 0 High	32u	Measurement value in μm (0x80000000 if invalid)
1001	Measurement 0 Low		
1002	Decision 0	16u	Measurement decision. A bit mask, where: Bit 0: 1 - Pass 0 - Fail Bits 1-7: 0 - Measurement value OK 1 - Invalid value 2 - Invalid anchor
1003	Measurement 1 High		
1004	Measurement 1 Low		
1005	Decision 1		
1006	Measurement 2 High		
1007	Measurement 2 Low		
1008	Decision 2		
...
1996	Measurement 332 High		
1997	Measurement 332 Low		
1998	Decision 332		

EtherNet/IP Protocol

EtherNet/IP is an industrial protocol that allows bidirectional data transfer with PLCs. It encapsulates the object-oriented Common Industrial Protocol (CIP). EtherNet/IP communication enables the client to:

- Switch jobs.
- Align and run sensors.
- Receive sensor states, stamps, and measurement results.
- Set and retrieve runtime variables.

This section describes the EtherNet/IP messages and data formats.

Note that in firmware version 5.2, the identity information was updated as follows:

Attribute	Before Firmware 5.2	Firmware 5.2 and later
Product Code	Was 1000, 2000, or 3000 depending on the model.	Now 1.
Major Revision	Matched firmware major version.	Now 1.
Minor Revision	Matched firmware minor version.	Now 1.

This update may require a change on a device attempting to connect to a sensor via EtherNet/IP. A compatible EDS file can be downloaded from the web interface. If the existing EDS must be maintained, the device can be configured to disable electronic keying, ignoring the product code and version numbers.

To use the EtherNet/IP protocol, it must be enabled and configured in the active job. For information on configuring the protocol using the Web interface, see *Ethernet Output* on page 235.

 The Gocator 4.x/5.x firmware uses mm, mm², mm³, and degrees as standard units. In all protocols, values are scaled by 1000, as values in the protocols are represented as integers. This results in effective units of mm/1000, mm²/1000, mm³/1000, and deg/1000 in the protocols.

Sensors support unconnected or connected explicit messaging (with TCP), as well as implicit (or I/O) messaging. For information on explicit messaging assemblies and objects, see *Explicit Messaging* below. For information on implicit messaging assemblies and objects, see *Implicit Messaging* on page 416.

Explicit Messaging

To EtherNet/IP-enabled devices on the network, the sensor information is seen as a collection of objects, which have attributes that can be queried.

Sensors support all required objects for explicit messaging, such as the [Identity](#) object, [TCP/IP](#) object, and [Ethernet Link](#) object. In addition, an [Assembly object](#) is used for sending sensor and sample data and receiving commands. The Assembly object contains four assemblies: the command assembly (32 bytes),

the runtime variable configuration assembly (64 bytes), the sensor state assembly (100 bytes), and the sample state assembly object (380 bytes). The data attribute (0x03) of the assembly objects is a byte array containing information about the sensor. The data attribute can be accessed with the Get Attribute and Set Attribute commands.

The PLC sends a command to start a sensor. The PLC then periodically queries the attributes of the assembly objects for its latest measurement results. In EtherNet/IP terminology, the PLC is a scanner and the sensor is an adapter.

For detailed information on setting up explicit messaging using Allen-Bradley PLCs, see <https://downloads.lmi3d.com/setting-ethernetip-explicit-messaging-allen-bradley-plcs>.

The following sections describe the explicit messaging assemblies and objects.

Identity Object (Class 0x01)

Attribute	Name	Type	Value	Description	Access
1	Vendor ID	UINT	1256	ODVA-provided vendor ID	Get
2	Device Type	UINT	43	Device type	Get
3	Product Code	UINT	1	Product code	Get
4	Revision	USINT	1.1	Byte 0 - 1 Byte 1 - 1	Get
6	Serial number	UDINT	32-bit value	Sensor serial number	Get
7	Product Name	SHORT STRING 32	"Gocator"	Gocator product name	Get

TCP/IP Object (Class 0xF5)

The TCP/IP Object contains read-only network configuration attributes such as IP Address. TCP/IP configuration via Ethernet/IP is not supported. See Volume 2, Chapter 5-3 of the CIP Specification for a complete listing of TCP/IP object attributes.

Attribute	Name	Type	Value	Description	Access
1	Status	UDINT	0	TCP interface status	Get
2	Configuration Capability	UINT	0		Get
3	Configuration Control	UINT	0	Product code	Get
4	Physical Link Object	Structure (See description)		See 5.3.3.2.4 of CIP Specification Volume 2: Path size (UINT) Path (Padded EPATH)	Get
5	Interface Configuration	Structure (See description)		See 5.3.3.2.5 of CIP Specification Volume 2: IP address (UDINT) Network mask (UDINT)	Get

Attribute	Name	Type	Value	Description	Access
				Gateway address (UDINT)	
				Name server (UDINT)	
				Secondary name (UDINT)	
				Domain name (UDINT)	

Ethernet Link Object (Class 0xF6)

The Ethernet Link Object contains read-only attributes such as MAC Address (Attribute 3). See Volume 2, Chapter 5-4 of the CIP Specification for a complete listing of Ethernet Link object attributes.

Attribute	Name	Type	Value	Description	Access
1	Interface Speed	UDINT	1000	Ethernet interface data rate (mbps)	Get
2	Interface Flags	UDINT		See 5.4.3.2.1 of CIP Specification Volume 2: Bit 0: Link Status 0 - Inactive 1 - Active Bit 1: Duplex 0 - Half Duplex 1 - Full Duplex	Get
3	Physical Address	Array of 6 USINTs		MAC address (for example: 00 16 20 00 2E 42)	Get

Assembly Object (Class 0x04)

For explicit messaging, the Ethernet/IP object model includes the following assemblies: command, runtime variable configuration, sensor state, and sample state.

All assembly object instances are static. Data in a data byte array in an assembly object are stored in the big endian format.

Command Assembly

The command assembly object is used to start, stop, and align the sensor, and also to switch jobs on the sensor.

Command Assembly

Information	Value
Class	0x4
Instance	0x310
Attribute Number	3
Length	32 bytes
Supported Service	0x10 (SetAttributeSingle)

Attributes 1 and 2 are not implemented, as they are not required for the static assembly object.

Attribute 3

Attribute	Name	Type	Value	Description	Access
3	Command	Byte Array	See Below	Command parameters Byte 0 - Command. See table below for specification of the values.	Get, Set

Command Definitions

Value	Name	Description
0	Stop running	Stop the sensor. No action if the sensor is already stopped
1	Start Running	Start the sensor. No action if the sensor is already started.
2	Stationary Alignment	Start the stationary alignment process. Byte 1 of the sensor state assembly will be set to 1 (busy) until the alignment process is complete, then back to zero.
3	Moving Alignment	Start the moving alignment process. Byte 1 of the sensor state assembly will be set to 1 (busy) until the alignment process is complete, then back to zero.
4	Clear Alignment	Clear the alignment.
5	Load Job	Load the job. Set bytes 1-31 to the file name (one character per byte. File name must be null-terminated. The job name and extension are case-sensitive. If the extension ".job" is missing, it is automatically appended to the file name.
6	Reserved	Do not use.
7	Software trigger	Sends a software trigger to the sensor to capture one frame. The sensor must already be running, and its trigger mode must be set to "Software". Otherwise, software trigger has no effect.

Runtime Variable Configuration Assembly

The runtime variable configuration assembly object contains the sensor's intended runtime variables.

Runtime Variable Configuration Assembly

Information	Value
Class	0x04
Instance	0x311
Attribute Number	3
Length	64 bytes
Supported Service	0x10 (SetAttributeSingle)

Attribute 3

Attribute	Name	Type	Value	Description	Access
3	Command	Byte Array	See below	Runtime variable configuration information. See below for more details.	Get

Sensor State Information

Byte	Name	Type	Description
0-3	Runtime Variable 0	32s	Stores the intended value of the Runtime Variable at index 0.
4-7	Runtime Variable 1	32s	Stores the intended value of the Runtime Variable at index 1.
8-11	Runtime Variable 2	32s	Stores the intended value of the Runtime Variable at index 2.
12-15	Runtime Variable 3	32s	Stores the intended value of the Runtime Variable at index 3.
16-63	Reserved		

Sensor State Assembly

The sensor state assembly object contains the sensor's states, such as the current sensor temperature, frame count, and encoder values.

Sensor State Assembly

Information	Value
Class	0x04
Instance	0x320
Attribute Number	3
Length	100 bytes
Supported Service	0x0E (GetAttributeSingle)

Attributes 1 and 2 are not implemented, as they are not required for the static assembly object.

Attribute 3

Attribute	Name	Type	Value	Description	Access
3	Command	Byte Array	See below	Sensor state information. See below for more details.	Get

Sensor State Information

Byte	Name	Type	Description
0	Sensor State		Sensor state: 0 - Stopped 1 - Running
1	EtherNet/IP Command in Progress		Command busy status: 0 - Not busy 1 - Busy performing the last command Bytes 2 and 19-83 below are only valid when there is no command in progress.
2	Alignment State		Alignment status: 0 - Not aligned

Byte	Name	Type	Description
			1 - Aligned The value is only valid when byte1 is set to 0.
3-10	Encoder	64s	Current encoder position
11-18	Time	64s	Current timestamp
19	Current Job Filename Length	8u	Number of characters in the current job filename. (e.g., 11 for "current.job"). The length includes the .job extension. Valid when byte 1 = 0.
20-83	Current Job Filename		Name of currently loaded job, including the ".job" extension. Each byte contains a single character. Valid when byte 1 = 0.
84-87	Runtime Variable 0	32s	Runtime variable value at index 0
...	...		
96-99	Runtime Variable 3	32s	Runtime variable value at index 3

Sample State Assembly

The sample state object contains measurements and their associated stamp information.

Sample State Assembly

Information	Value
Class	0x04
Instance	0x321
Attribute Number	3
Length	380 bytes
Supported Service	0x0E (GetAttributeSingle)

Attribute 3

Attribute	Name	Type	Value	Description	Access
3	Command	Byte Array	See below	Sample state information. See below for more details.	Get

Sample State Information

Byte	Name	Type	Description
0-1	Inputs	16u	Digital input state of the last frame.
2-9	Z Index Position	64u	Encoder position at time of last index pulse of the last frame.
10-13	Exposure	32u	Laser exposure in μ s of the last frame.
14-17	Temperature	32u	Sensor temperature in degrees Celsius * 100 (centidegrees) of the last frame.

Byte	Name	Type	Description
18-25	Encoder Position	64u	Encoder position of the last frame when the image data was scanned/taken.
26-33	Time	64u	Time stamp in microseconds of the last frame.
34-41	Frame Counter	64u	The frame number of the last frame.
42	Buffer Count	8u	Represents the number of frames waiting to be output if buffering is enabled.
43	Buffer Overflowing	8u	Indicates whether the output buffer has overflowed: 0 - No overflow 1 - Overflow
44 - 79	Reserved		Reserved bytes.
80-83	Measurement 0	32s	Measurement value in μm (0x80000000 if invalid).
84	Decision 0	8u	Measurement decision. A bit mask, where: Bit 0: 1 - Pass 0 - Fail Bits 1-7: 0 - Measurement value OK 1 - Invalid value 2 - Invalid anchor
...	...		
375-378	Measurement 59	32s	Measurement value in μm (0x80000000 if invalid).
379	Decision 59	8u	Measurement decision. A bit mask, where: Bit 0: 1 - Pass 0 - Fail Bits 1-7: 0 - Measurement value OK 1 = Invalid value 2 = Invalid anchor

Measurement results are reported in pairs of values and decisions. Measurement values are 32 bits wide and decisions are 8 bits wide.

The measurement ID defines the byte position of each pair within the state information. The position of the first word can be calculated as $(80 + 5 * \text{ID})$. For example, a measurement with ID set to 4 can be read from byte 100 (high word) to 103 (low word) and the decision at 104.

If buffering is enabled in the Ethernet Output panel, reading the Extended Sample State Assembly Object automatically advances the buffer. See *Ethernet Output* on page 235 for information on the **Output** panel.

Implicit Messaging

Implicit messaging uses UDP and is faster than explicit messaging, and is ideal for time-critical applications. However, implicit messaging is layered on top of UDP. UDP is connectionless and data delivery is not guaranteed. For this reason, implicit messaging is only suitable for applications where occasional data loss is acceptable.

For detailed information on setting up implicit messaging using Allen-Bradley PLCs, see http://lmi3d.com/sites/default/files/APPNOTE_Implicit_Messaging_with_Allen-Bradley_PLCs.pdf.

The following sections describe the implicit messaging assemblies.

Assembly Object (Class 0x04)

For implicit messaging, the Ethernet/IP object model includes the following assemblies: implicit messaging command and implicit messaging output.

All assembly object instances are static. Data in a data byte array in an assembly object are stored in the big endian format.

Implicit Messaging Command Assembly

Implicit Messaging Command Assembly

Information	Value
Class	0x04
Instance	0x64
Attribute Number	3
Length	32 bytes

Implicit Messaging Command Assembly Information

Byte	Name	Type	Description
0	Command	8u	A bit mask where setting the following bits will only perform the action with highest priority*: 1 – Stop sensor 2 – Start sensor 4 – Perform stationary alignment 8 – Perform moving alignment 16 – Clear alignment 32 – Set runtime variables 64 – Load job file 128 – Software trigger

Byte	Name	Type	Description
			<p>*The priority of commands is currently as follows:</p> <ol style="list-style-type: none"> 1. Stop sensor 2. Start sensor 3. Perform stationary alignment 4. Perform moving alignment 5. Clear alignment 6. Set runtime variables 7. Load job file 8. Software trigger
1-31	Reserved (except for configuring runtime variables and loading job file)		<p>If you are setting the runtime variables, use bytes 4-19 to define the values of each of the four runtime variables in little endian format.</p> <p>If you are loading job file, use bytes 1-31 for the filename, one character per byte. The job name and extension are case-sensitive. The filename must be null terminated and must end with ".job".</p>

Implicit Messaging Output Assembly

Implicit Messaging Output Assembly

Information	Value
Class	0x04
Instance	0x322
Attribute Number	3
Length	376 bytes

Implicit Messaging Output Assembly Information

Byte	Name	Type	Description
0	Sensor State	8u	<p>Sensor state is a bit mask where:</p> <p>Bit 0:</p> <p>1 – Running</p> <p>0 – Stopped</p> <p>Bit 1:</p> <p>1 – Conflict due to unreachable buddy</p> <p>0 – No conflict</p> <p>Bits [2-7]: Not used.</p>
1	Alignment and Command state	8u	<p>A bit mask where:</p> <p>Bit 0:</p>

Byte	Name	Type	Description
			1 – Explicit or Implicit Command in progress 0 – No Explicit or Implicit command is in progress Bit 1 1 – Aligned 0 – Not aligned
2-3	Inputs	16u	Digital input state of the last frame.
4-11	Z Index Position	64u	Encoder position at time of last index pulse of the last frame.
12-15	Exposure	32u	Exposure in μ s of the last frame.
16-19	Temperature	32u	Sensor temperature in degrees celsius * 100 (centidegrees) of the last frame.
20-27	Encoder Position	64s	Encoder position of the last frame when the image data was scanned/taken.
28-35	Time	64u	Time stamp in microseconds of the last frame.
36-43	Frame Index	64u	The frame number of the last frame.
44-55	Reserved		
56	Decision 0	8u	Measurement decision is a bit mask where: Bit 0: 1 – Pass 0 – Fail Bits [1-7]: 0 – Measurement value OK 1 – Invalid Value 2 – Invalid Anchor
...	...		
119	Decision 63	8u	Measurement decision is a bit mask where: Bit 0: 1 – Pass 0 – Fail Bits [1-7]: 0 – Measurement value OK 1 – Invalid Value 2 – Invalid Anchor
120-123	Measurement 0	32s	Measurement value in μ m. (0x80000000 if invalid)

Byte	Name	Type	Description
...	...		
372-375	Measurement 63	32s	Measurement value in μm . (0x80000000 if invalid)

Rockwell Allen-Bradley Instructions

This section describes how to set up network communications over the EtherNet/IP industrial communication protocol with Allen-Bradley PLCs that are EtherNet/IP-capable. Gocator supports two EtherNet/IP messaging methods: implicit messaging via UDP and explicit messaging via TCP.

Implicit messaging has advantages and disadvantages. Implicit messaging uses UDP and is faster than explicit messaging and is ideal for time-critical applications. Since implicit messaging is layered on top of UDP, it is connectionless and data delivery is not guaranteed. For this reason, implicit messaging is only suitable for applications where occasional data loss is acceptable. Two connection types are available for implicit communication: a Monitor Data connection or a Monitor Data and Control Data connection.

Explicit messaging is more suitable for deterministic and verified communication transfer where no losses are acceptable. Add-On Profile (AOP) is not available for the Gocator, and it is not possible to use the EDS file for automatic configuration.

For these reasons, LMI recommends in most application using a closed ethernet subnet (i.e., network switch, PLC, Gocator(s), and setup PC only) to minimize losses and collisions and cyclical implicit messaging over the EtherNet/IP protocol unless a specific control command such as job loading and/or transfer verification is required.

Software and Hardware Setup

The following software and hardware were used during development.

Requirements	Details
Gocator Firmware	5.2 and higher
Gocator Series	G1, G2, and G3 sensors.
Required Files	GocatorEip.eds LMI.ico Gocator_EthernetIP.ACD
Other	Allen-Bradley L16ER-BB1B PLC Allen-Bradley Studio 5000 programming tool V21.11 or newer D-Link Unmanaged Industrial Gigabit Ethernet Switch DGS-108

Note: The Ethernet card to which the Gocator is connected should be added as a module to the Backplane. Verify that the IP Address is on the correct subnet. Note the IP address should be that of the PLC's Ethernet modules, not that of the Gocator's.

Byte Order Options

Gocator supports outputting in either Big Endian or Little Endian byte ordering options.

Big Endian Byte Order: The most significant byte (the "big end") of the data is placed at the byte with the lowest address. The rest of the data is placed in order of decreasing significance in the next three bytes of memory.

Little Endian Byte Order: The least significant byte (the "little end") of the data is placed at the byte with the lowest address. The rest of the data is placed in order of increasing significance in the next three bytes in memory.

Most Allen-Bradley PLCs default to Little Endian addressing formats, but you should verify this when configuring the PLC.

Setting Up Implicit Messaging on the Gocator

To output in EtherNet/IP implicit messaging mode on the sensor, you configure the sensor using the **Protocol** setting and the **Configuration** area on the **Output** page. Note that the *type* of implicit messaging (cyclic versus change of state) is determined by the **Trigger Override** setting.

Name	Register	Type
Command	0	8-bit
Arguments	1	var
State		
Sensor State	0	8-bit
Command in Progress	1	8-bit
Alignment State	2	8-bit
Encoder	3	64-bit
Time	11	64-bit
Job Name Length	19	8-bit
Job Name	20	var
Runtime Variables		
Index 0	84	32-bit
Index 1	88	32-bit
Index 2	92	32-bit
Index 3	96	32-bit
Stamp		

To configure the sensor for EtherNet/IP implicit messaging mode:

1. On the **Output** page, in the **Ethernet** category, choose **EtherNet/IP** as the protocol.
2. Choose **Little Endian** from the **Byte Order** dropdown box.
3. Make sure that **Explicit Message Buffering** is unchecked.
4. Check the **Implicit Messaging** option.
5. Set the **Trigger Override** dropdown to the type of implicit messaging you are using.

For cyclic messaging, set **Trigger Override** to **Force Cyclic**.

For change of state messaging, set **Trigger Override** to **Force Change of State**.

When you set up the PLC to communicate with a Gocator using change of state implicit messaging, an event task must be created on the PLC to rapidly check whether the sensor is running; if the frame count

increases, data is copied to an array. The event task period must allow the event task to be executed at a higher rate than Gocator frame rate. For more information, see TBD.

Before setting up implicit messaging on the PLC, you must download the EDS file from the Gocator sensor to the PC.

To download the EDS file:

1. Click Download EDS File to download the latest Gocator EDS file to the PC connected to the sensor.

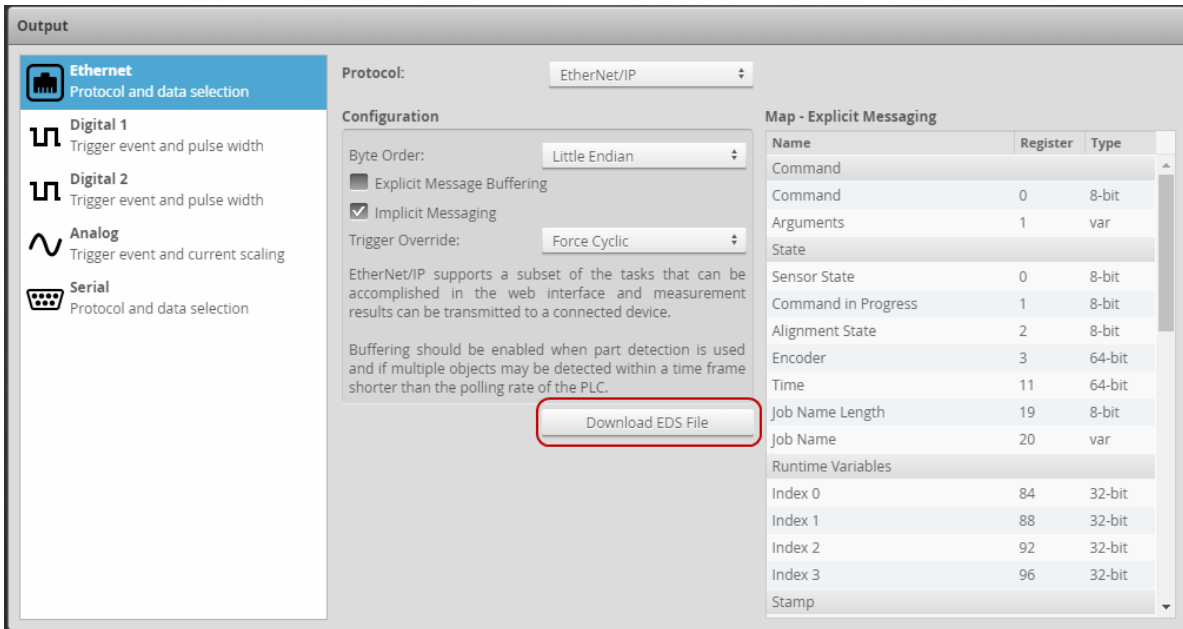

2. Click **Save** to save the zipped folder to a convenient location.

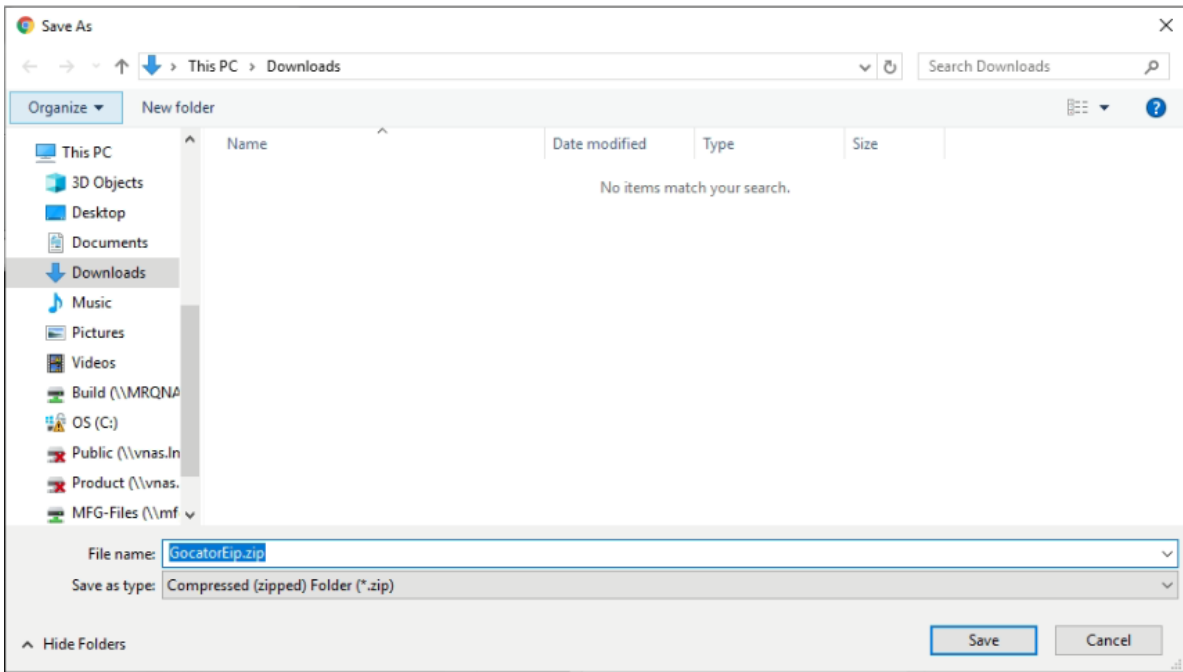

3. Extract the zipped folder.

Your unzipped folder will contain two files: a .eds file and a .ico file.

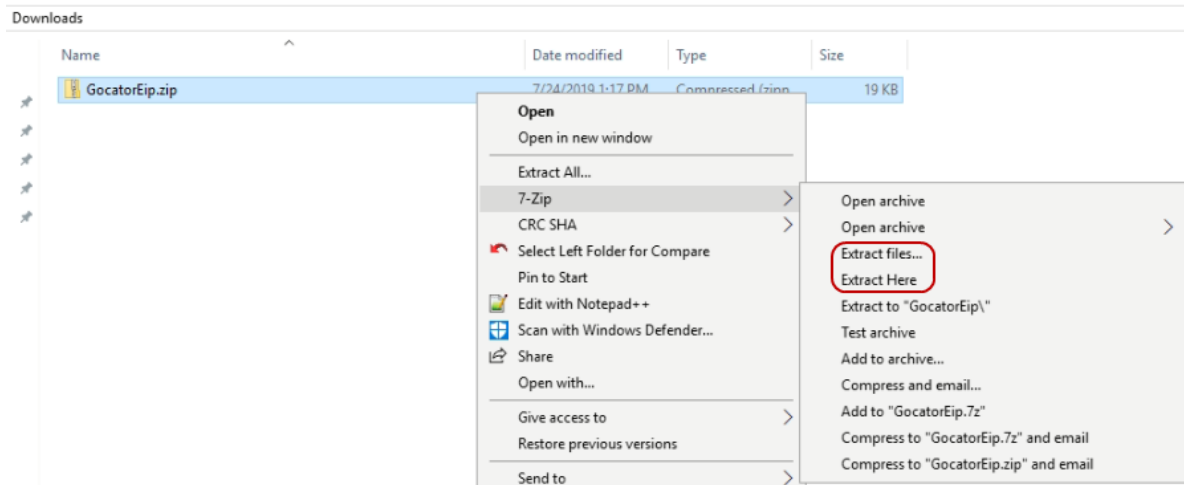

4. Make note of where you have extracted the EDS file.

Setting Up Implicit Messaging on the PLC

This section describes setting up implicit messaging on the PLC.

Install EDS File

1. If you haven't already done so, download the EDS file from the Gocator sensor.
For more information, see *To download the EDS file:* on the previous page.
2. In Studio 5000, under the **Tools** menu, click **EDS Hardware Installation Tool**.

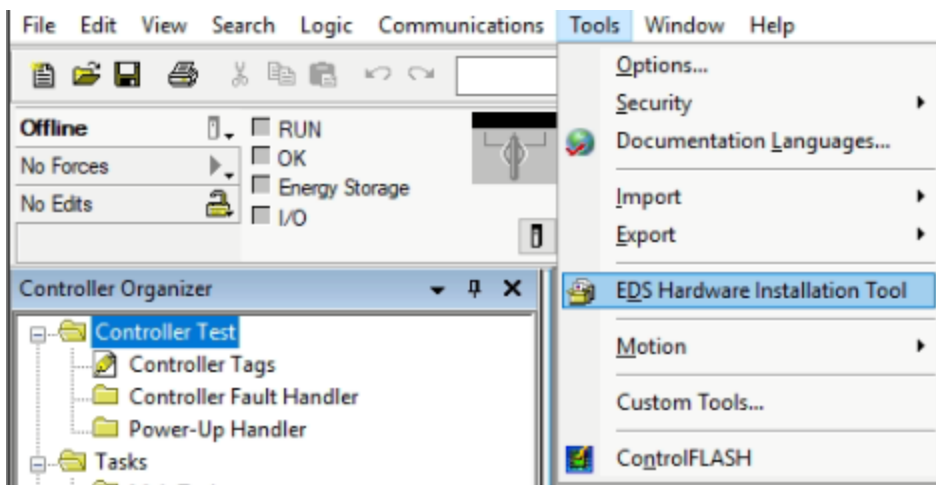

The EDS setup tool (the Rockwell Automation EDS Wizard) launches.

3. In the wizard, click **Next**.



4. Choose **Register an EDS file(s)** and click **Next**

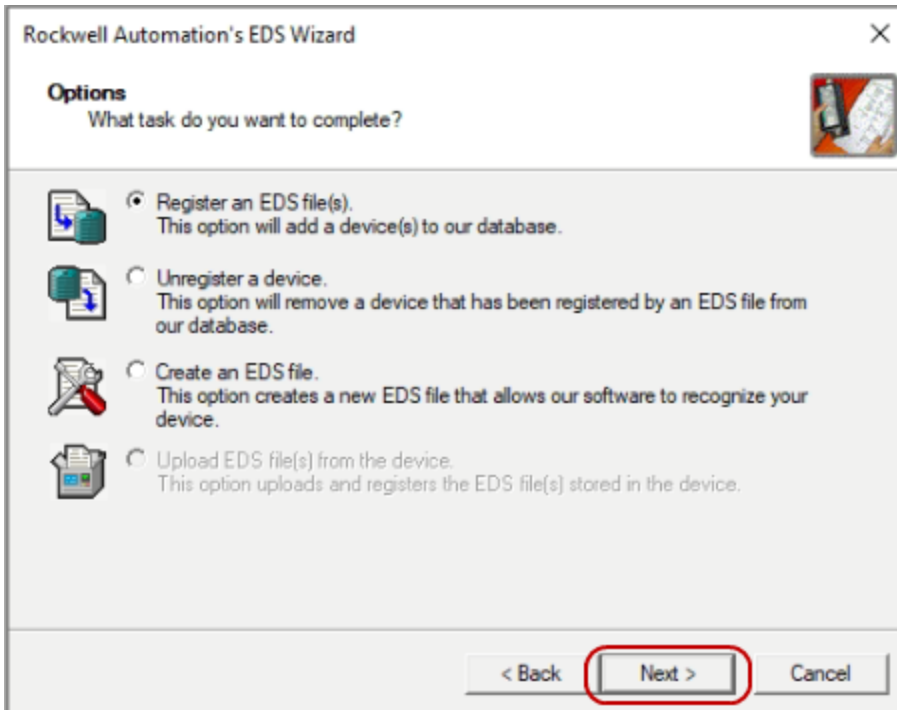

5. Choose **Register a single file** and then click **Browse**.

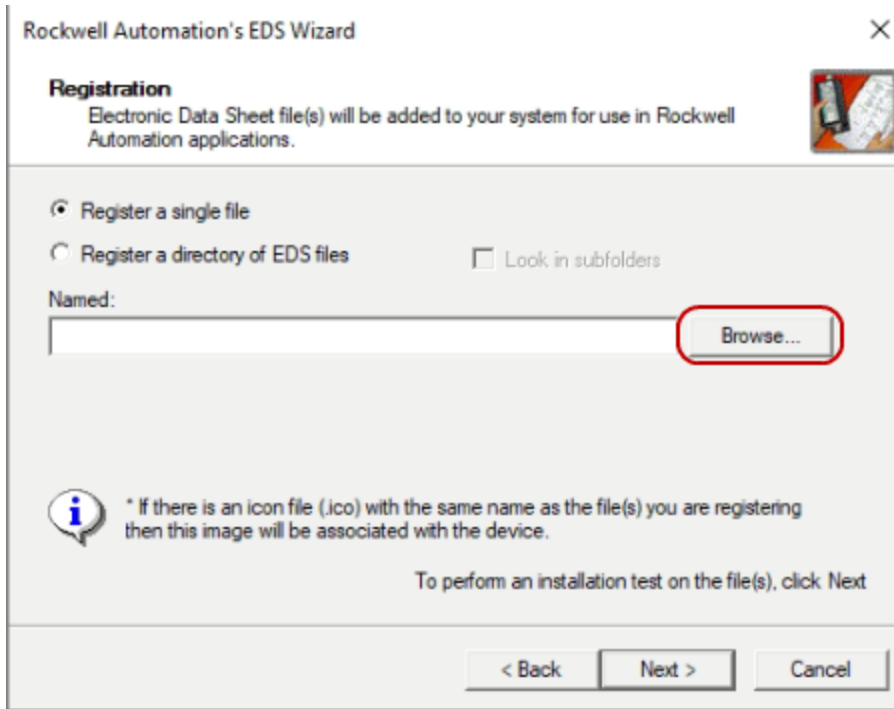

6. Navigate to the unzipped .eds file you downloaded and unzipped, select it, and click **Open**.

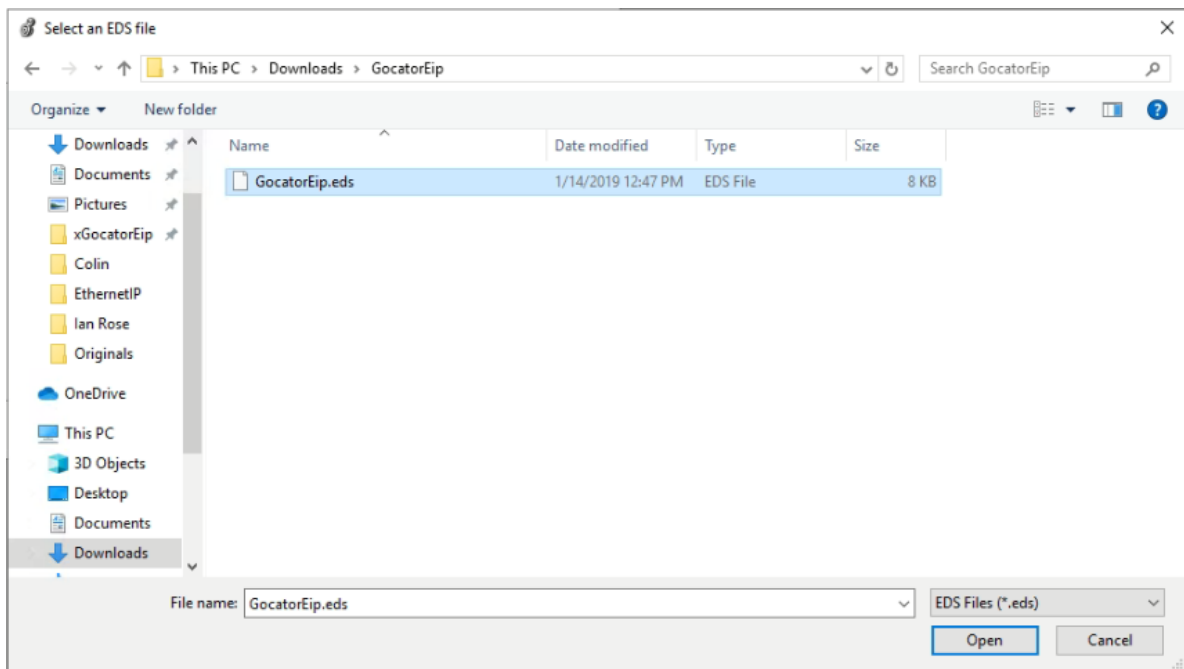

7. Click **Next**.

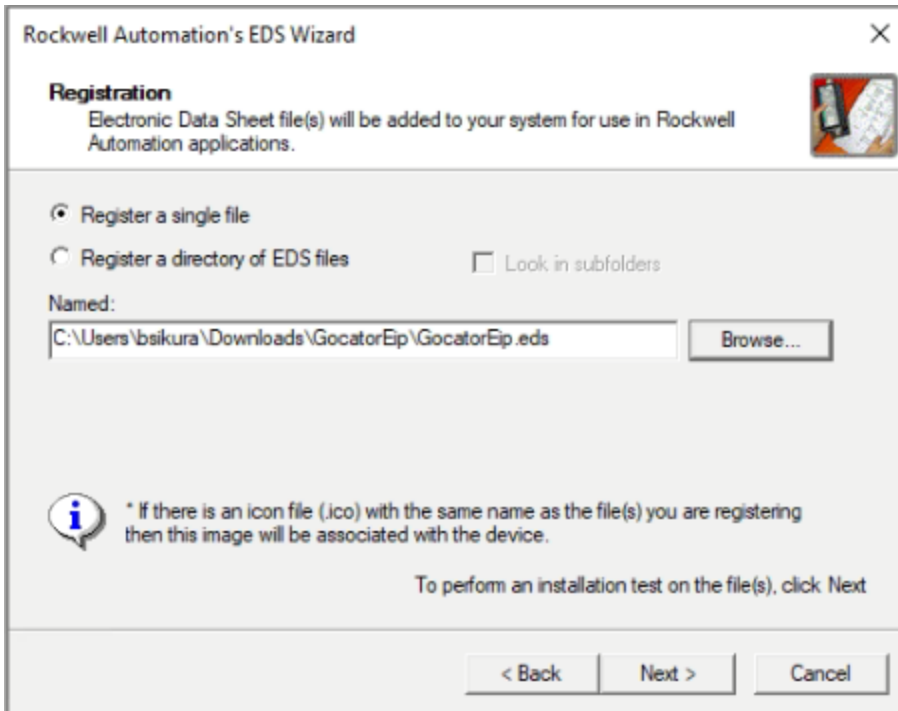

8. If your EDS file has no errors or conflicts (a green checkmark is displayed next to the .eds file), click **Next**.

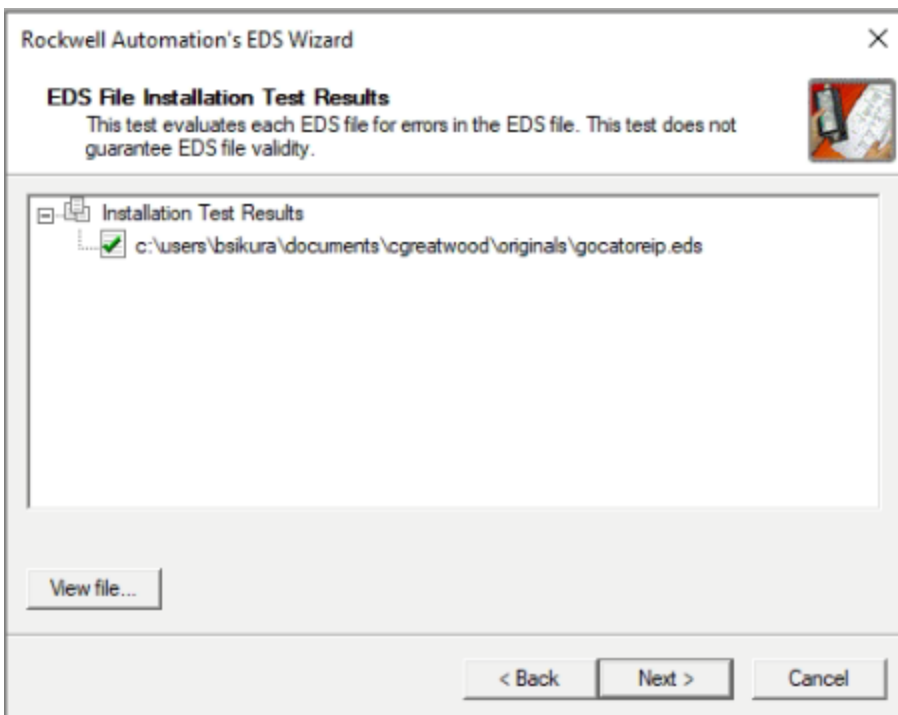

9. Verify that the tool automatically selects the LMI logo from the unzipped folder.
The .ico file contained in the zip folder you downloaded previously contains the logo.
10. If the tool does not automatically select the LMI logo, navigate to the file, select it, and then click **Next**.

Proper icon selection is important, as this will make it easier for maintenance/future engineers to identify the sensor product from a long list of connected devices in a PLC program.

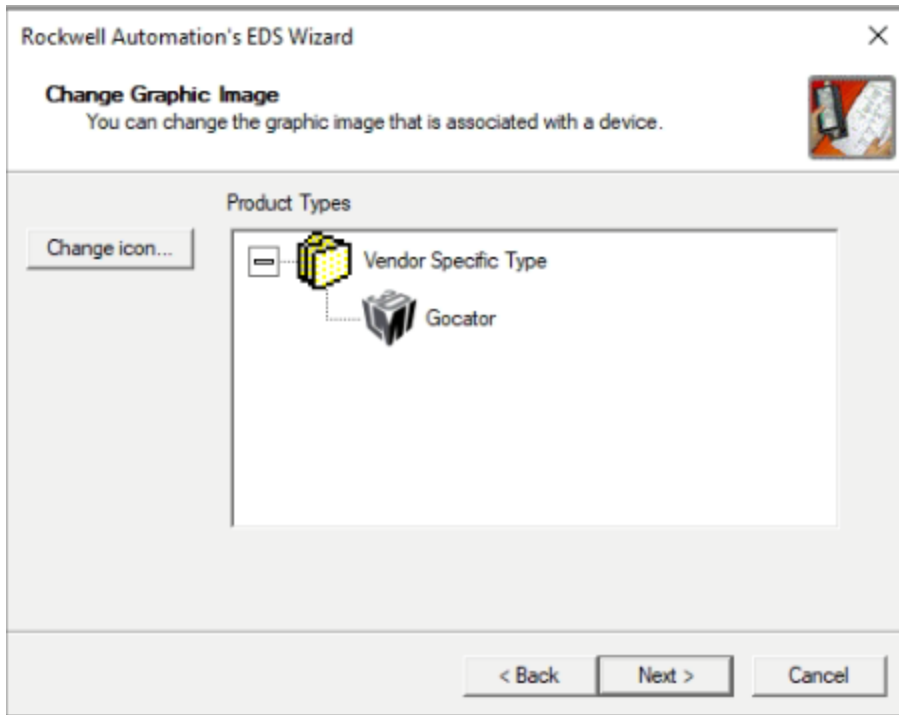

11. Click **Next**.

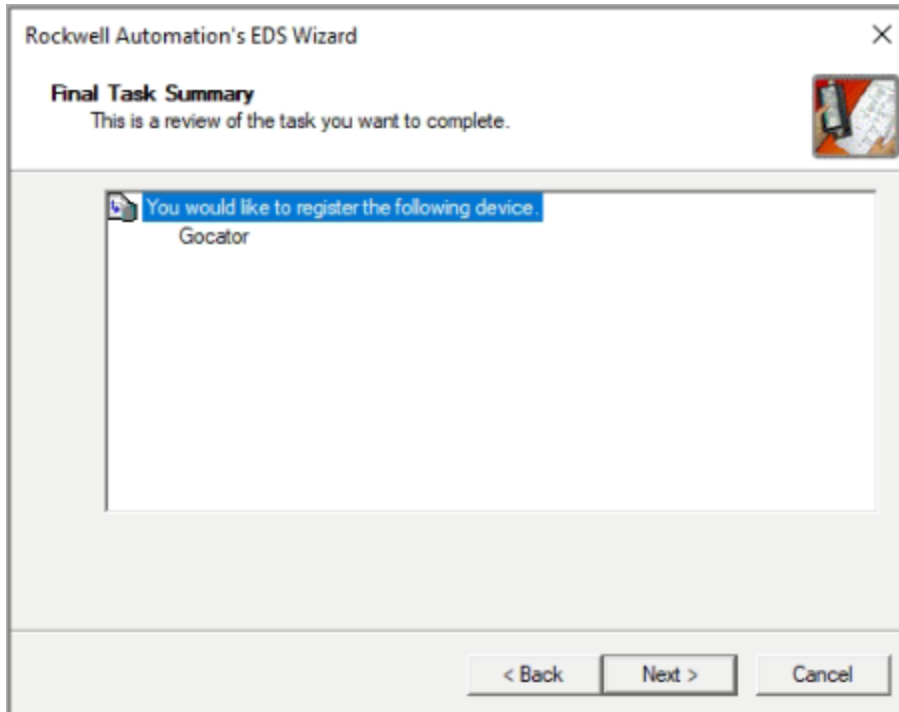

12. Click **Finish**.

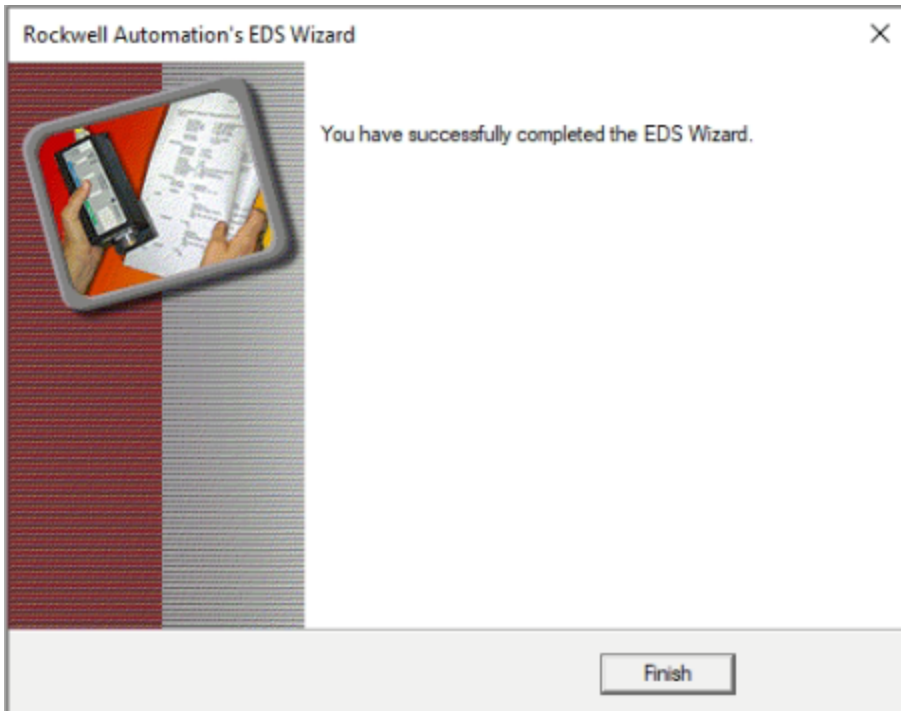

Add Gocator IO Device to PLC Program

1. Click the **Who Active** button to the right of the Path field.

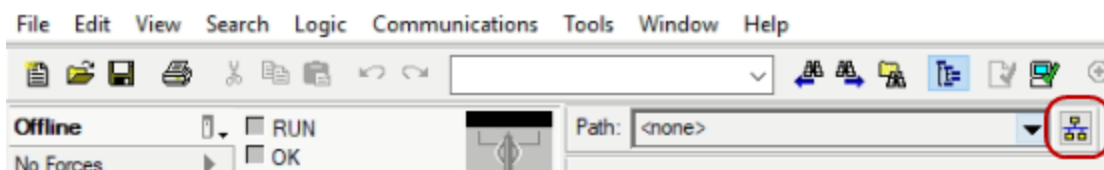

2. Click **Refresh** in RSLinx the **Who Active** dialog to update your available devices.

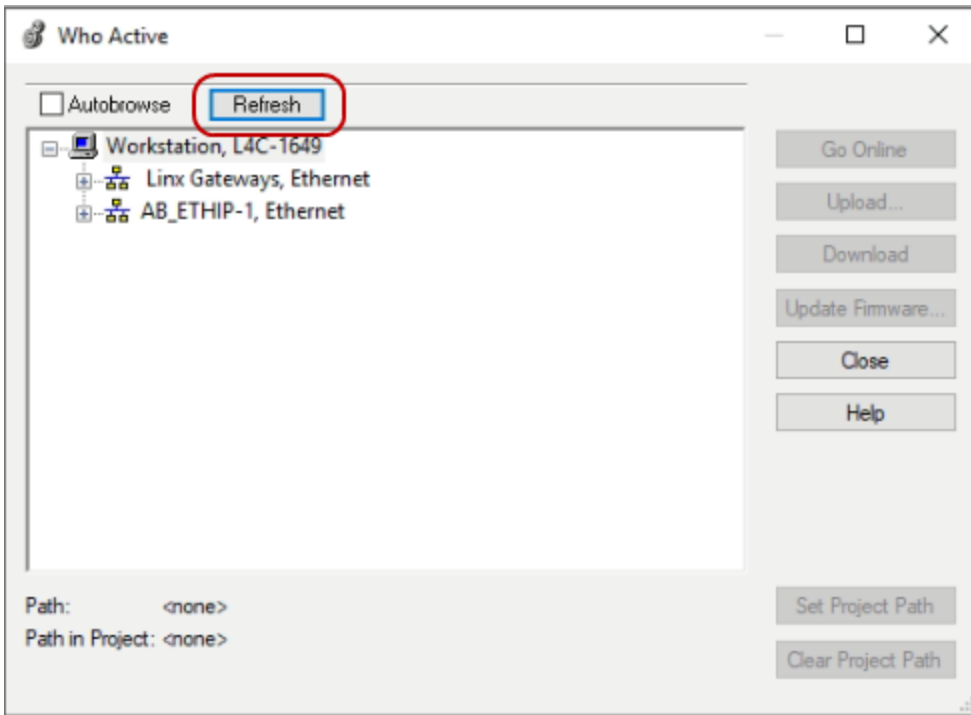

3. In the tree structure, navigate to and select your PLC controller ethernet node.

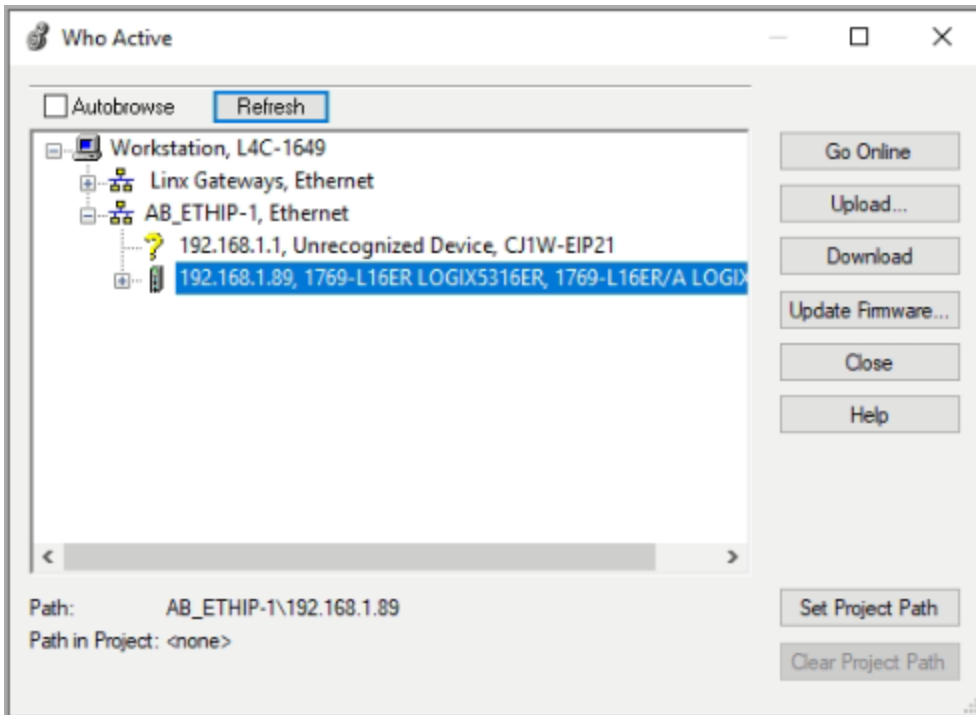

4. If you do not see the **Go Online** option at this point, make sure that RSLinx has been started and is running in the background on your setup PC.
Device discovery will not complete if RSLinx is not running.
5. Click **Set Project Path**.

This will set your project path when you attempt to download to the PLC later.

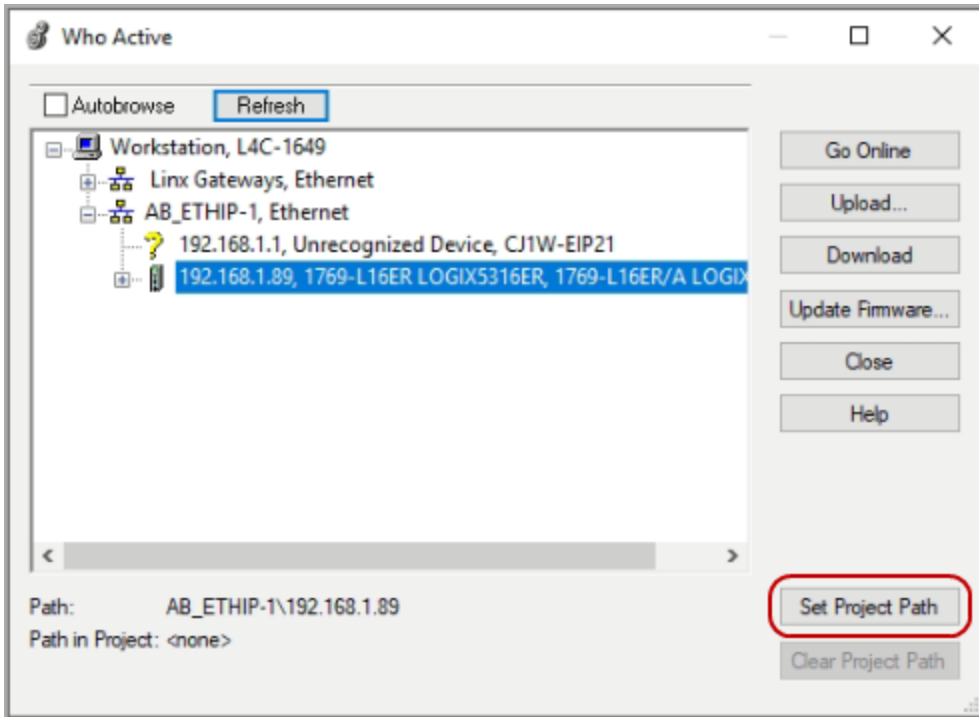

6. Click X to exit your node setup.

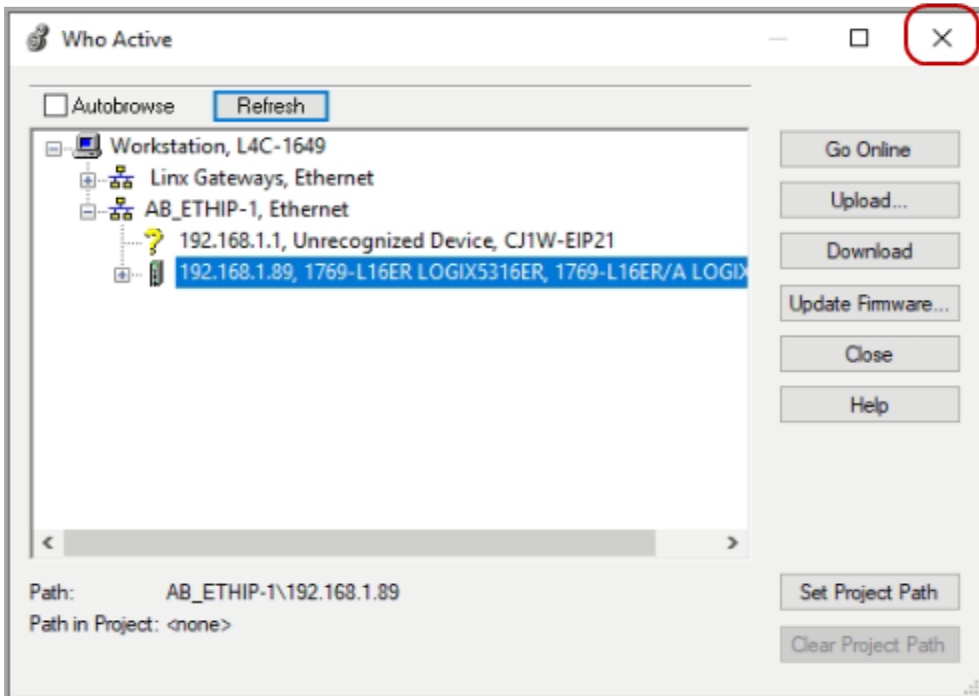

7. In Studio 5000, verify that the path is updated to the IP address of your controller.

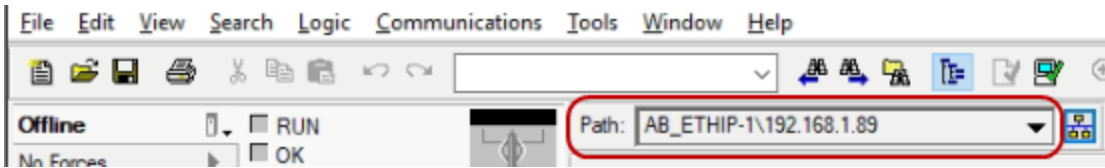

8. In the Controller Organizer, choose **Ethernet** under the **IO Configuration** node.

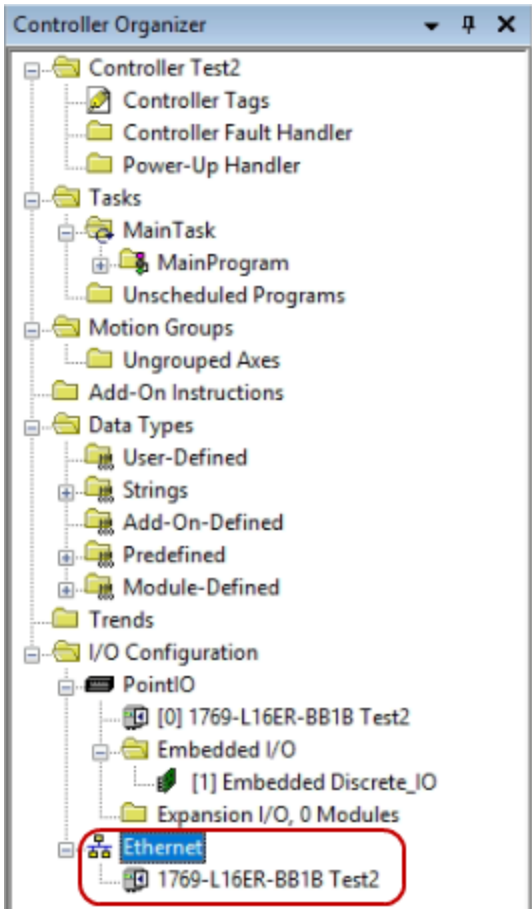

9. Right-click the Ethernet network node and click **New Module**.

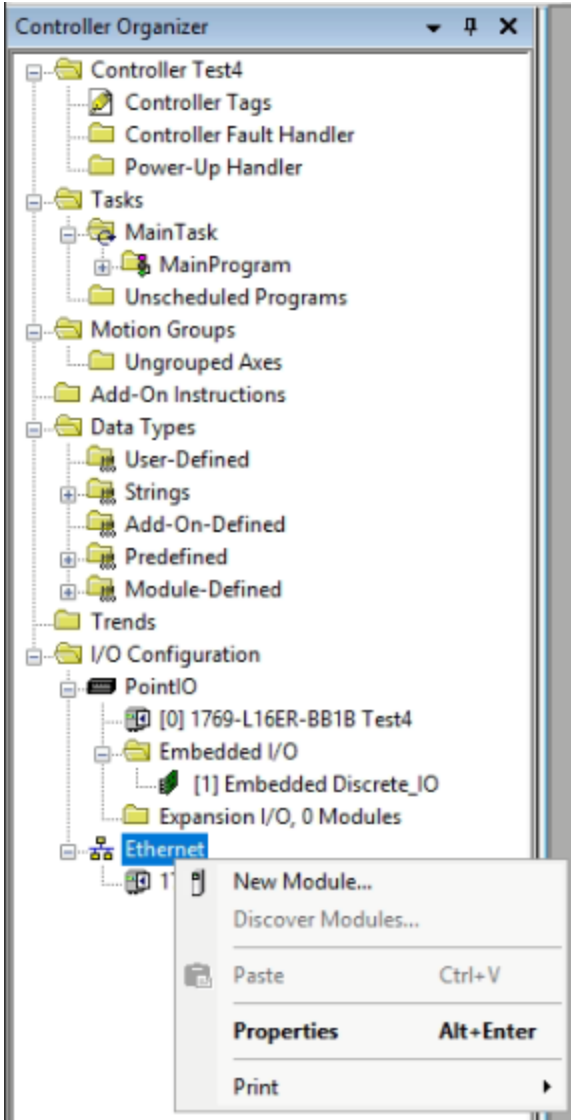

10. Type "Gocator" into the search bar of the dialog that appears.

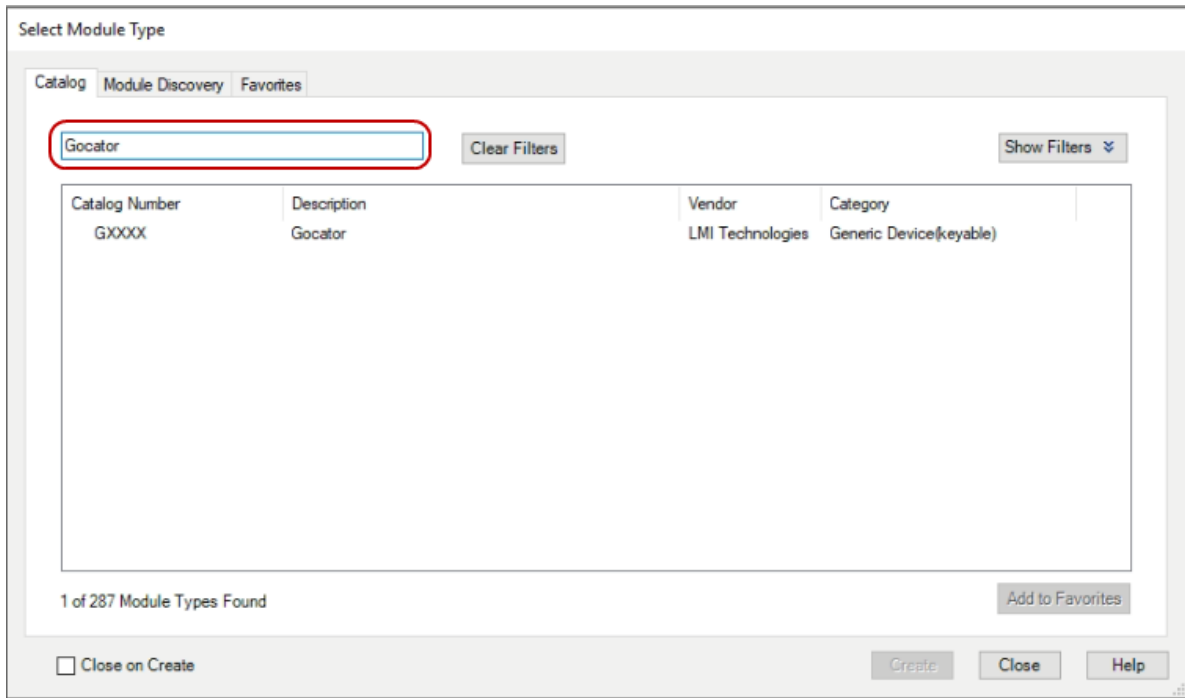

11. In the list under the search bar, select the new Gocator device file and click **Create**.

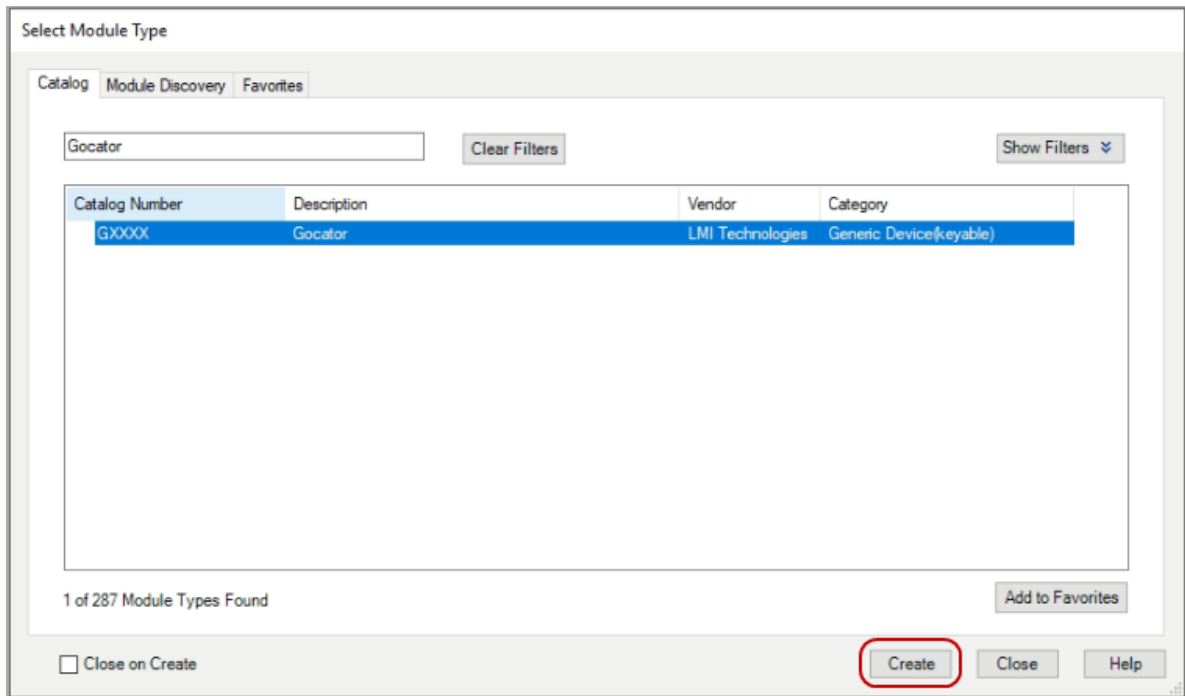

12. In the New Module dialog, in the **Name** field, give the new IO device a *unique* name.

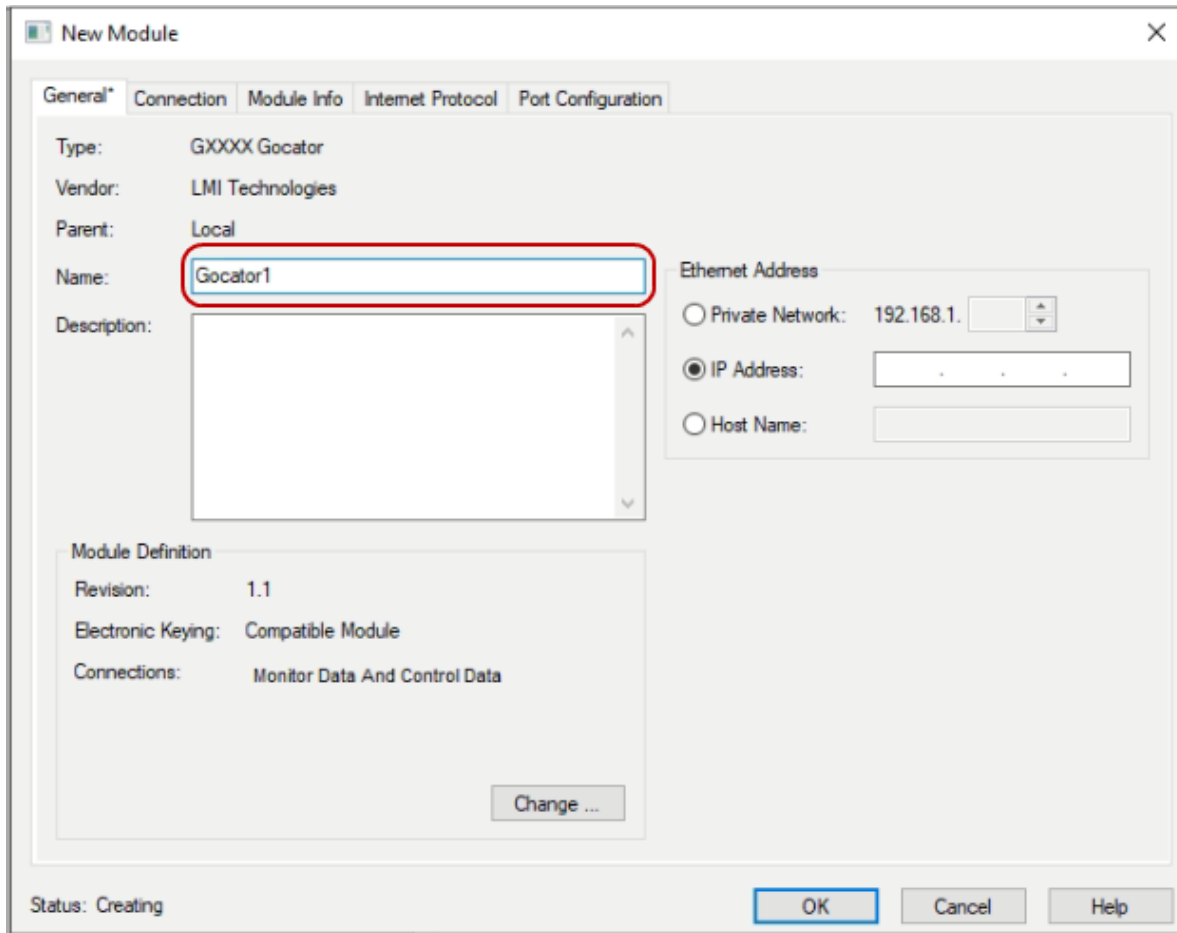

13. Type in the static IP address of the first sensor that you are trying to set up, and then click **OK**.

The default IP address for all Gocator sensors from the factory is 192.168.1.10. You can verify the IP address of the sensor by logging into the web user interface in a browser or by using the kDiscovery utility available in the GoUtilities package available from LMI's Download Center.

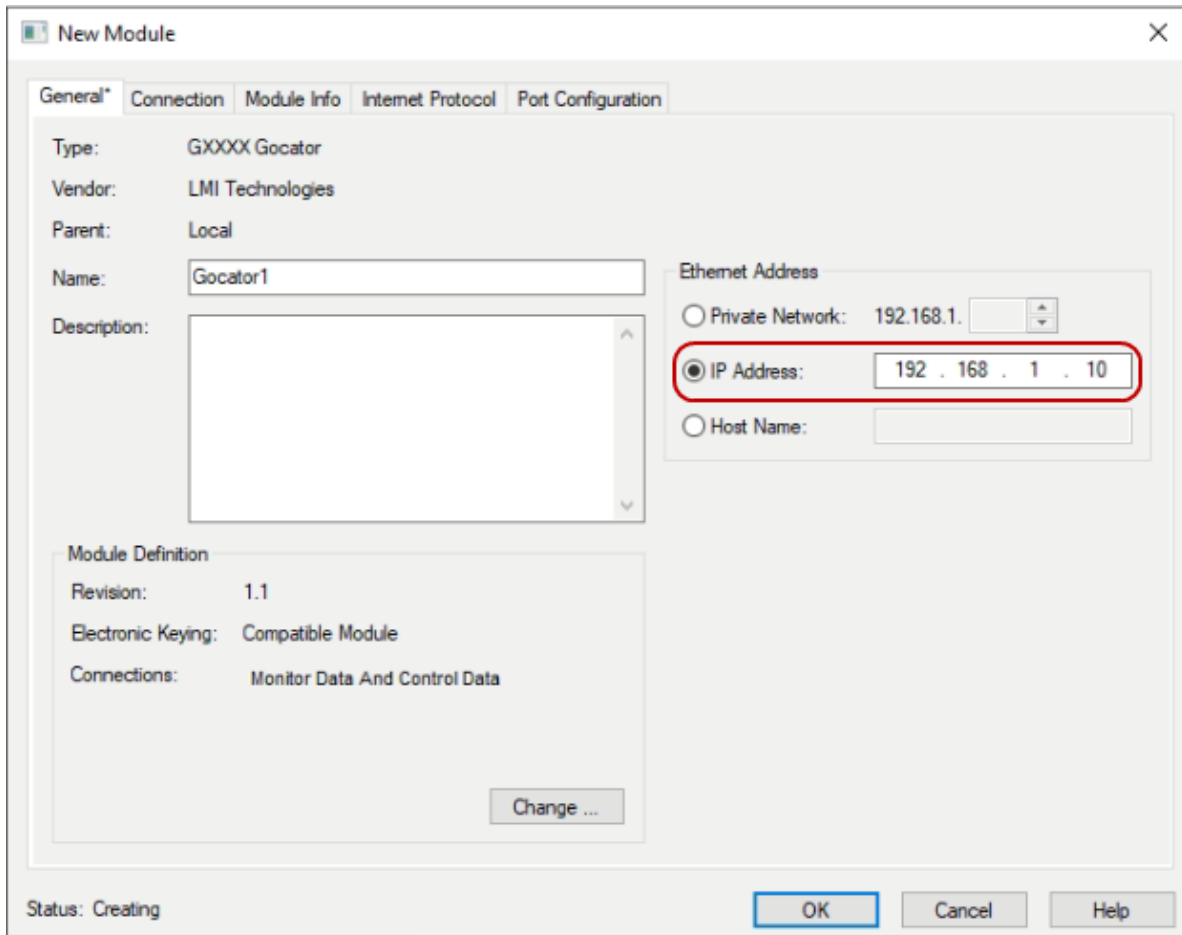

14. In your Program tree, verify that you now have a new IO device.
The naming format shown should be device devicename (i.e., GXXX Gocator1)

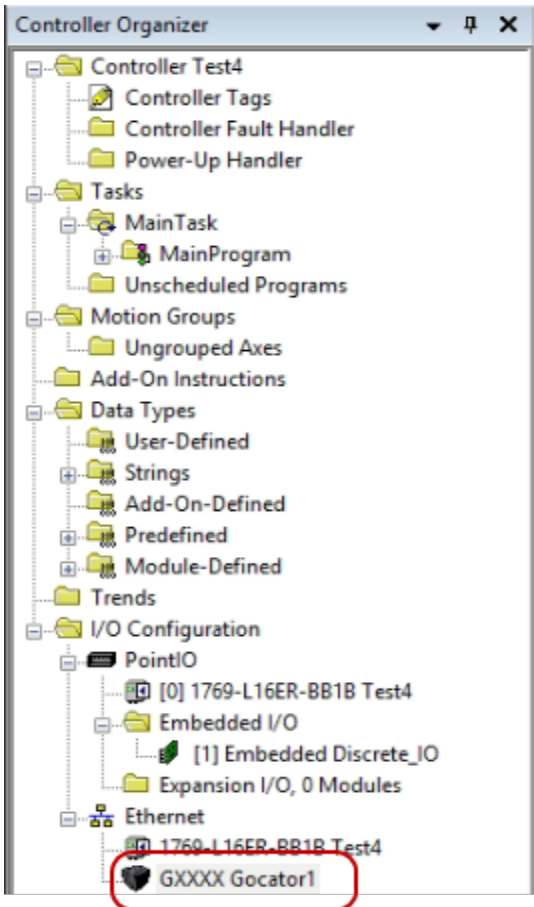

15. In the Select Module Type dialog, click **Close**.

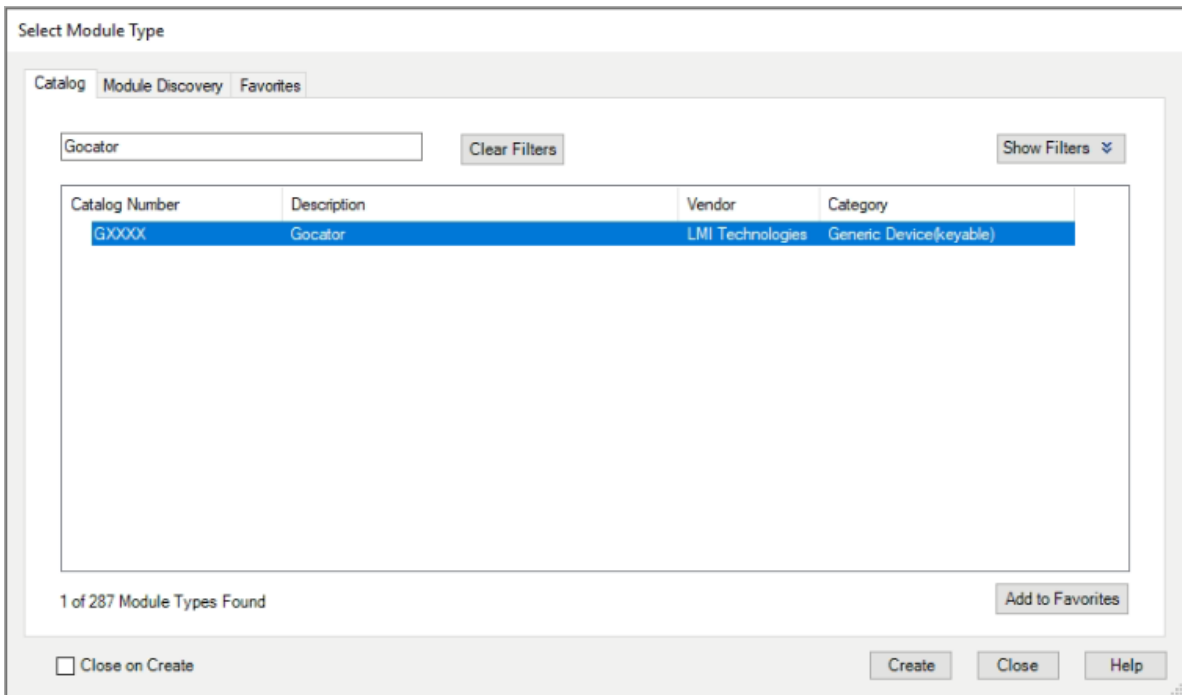

16. In the Controller Organizer, under **Data-Types**, expand **Module-Defined** and verify that you have two new data blocks.

These will correspond to the Input and Output data coming from and going to the Gocator, respectively, for a *Monitor Data and Control Data* connection type.

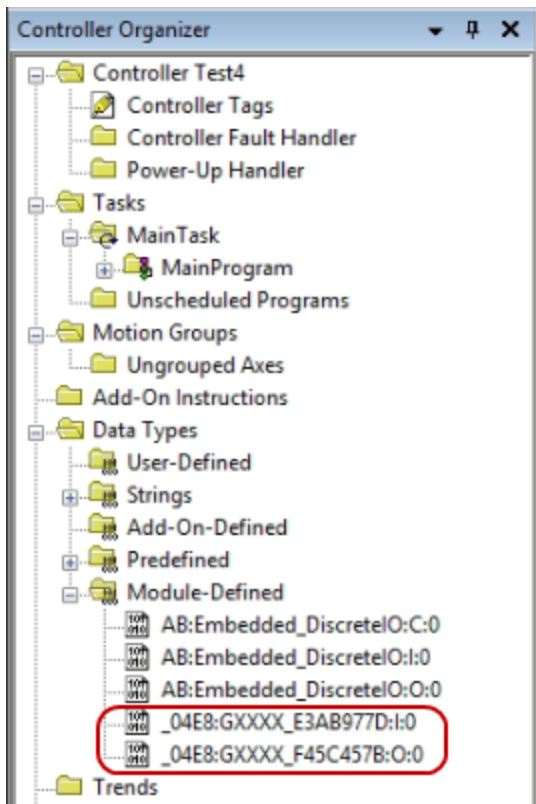

When the Gocator is in Implicit Messaging mode, data will be streamed and stored in the Gocator1:I tag when both the PLC is in Run mode and the Gocator is started. The tag address header is formatted as devicename:I and/or devicename:O for inputs and outputs, respectively.

For the data format, see *Implicit Messaging Output Assembly* on page 417.

The EDS file now contains detailed tag descriptions as shown below that can be used directly in the PLC program.

Name	Data Type	Name	Data Type	Name	Data Type	Name	Data Type
ConnectionFaulted	BOOL	Decision14	SINT	Decision52	SINT	Measurement26	DINT
Sensor_State	SINT	Decision15	SINT	Decision53	SINT	Measurement27	DINT
Run_State	BOOL	Decision16	SINT	Decision54	SINT	Measurement28	DINT
State_Issue1	BOOL	Decision17	SINT	Decision55	SINT	Measurement29	DINT
State_Issue2	BOOL	Decision18	SINT	Decision56	SINT	Measurement30	DINT
State_Issue3	BOOL	Decision19	SINT	Decision57	SINT	Measurement31	DINT
State_Issue4	BOOL	Decision20	SINT	Decision58	SINT	Measurement32	DINT
State_Issue5	BOOL	Decision21	SINT	Decision59	SINT	Measurement33	DINT
State_Issue6	BOOL	Decision22	SINT	Decision60	SINT	Measurement34	DINT
State_Issue7	BOOL	Decision23	SINT	Decision61	SINT	Measurement35	DINT
Alignment_and_Command_State	SINT	Decision24	SINT	Decision62	SINT	Measurement36	DINT
Command_in_Progress	BOOL	Decision25	SINT	Decision63	SINT	Measurement37	DINT
Aligned	BOOL	Decision26	SINT	Measurement0	DINT	Measurement38	DINT
Inputs	INT	Decision27	SINT	Measurement1	DINT	Measurement39	DINT
Z_Index_Position_0	DINT	Decision28	SINT	Measurement2	DINT	Measurement40	DINT
Z_Index_Position_1	DINT	Decision29	SINT	Measurement3	DINT	Measurement41	DINT
Exposure	DINT	Decision30	SINT	Measurement4	DINT	Measurement42	DINT
Temperature	DINT	Decision31	SINT	Measurement5	DINT	Measurement43	DINT
Encoder_Position_0	DINT	Decision32	SINT	Measurement6	DINT	Measurement44	DINT
Encoder_Position_1	DINT	Decision33	SINT	Measurement7	DINT	Measurement45	DINT
Time_0	DINT	Decision34	SINT	Measurement8	DINT	Measurement46	DINT
Time_1	DINT	Decision35	SINT	Measurement9	DINT	Measurement47	DINT
Frame_0	DINT	Decision36	SINT	Measurement10	DINT	Measurement48	DINT
Frame_1	DINT	Decision37	SINT	Measurement11	DINT	Measurement49	DINT
Decision0	SINT	Decision38	SINT	Measurement12	DINT	Measurement50	DINT
Decision1	SINT	Decision39	SINT	Measurement13	DINT	Measurement51	DINT
Decision2	SINT	Decision40	SINT	Measurement14	DINT	Measurement52	DINT
Decision3	SINT	Decision41	SINT	Measurement15	DINT	Measurement53	DINT
Decision4	SINT	Decision42	SINT	Measurement16	DINT	Measurement54	DINT
Decision5	SINT	Decision43	SINT	Measurement17	DINT	Measurement55	DINT
Decision6	SINT	Decision44	SINT	Measurement18	DINT	Measurement56	DINT
Decision7	SINT	Decision45	SINT	Measurement19	DINT	Measurement57	DINT
Decision8	SINT	Decision46	SINT	Measurement20	DINT	Measurement58	DINT
Decision9	SINT	Decision47	SINT	Measurement21	DINT	Measurement59	DINT
Decision10	SINT	Decision48	SINT	Measurement22	DINT	Measurement60	DINT
Decision11	SINT	Decision49	SINT	Measurement23	DINT	Measurement61	DINT
Decision12	SINT	Decision50	SINT	Measurement24	DINT	Measurement62	DINT
Decision13	SINT	Decision51	SINT	Measurement25	DINT	Measurement63	DINT

17. If you set the sensor to use change of state earlier (**Trigger Override** is set to **Force Change of State** in the Output panel), perform the following additional steps.
- In the RSLogix 5000 programming tool, create a new task with a 0.5 millisecond period and a 1.0 millisecond watchdog, and then click **OK** at the upper right.
A major fault alarm is triggered if the task does not finish execution within the watchdog time limit.

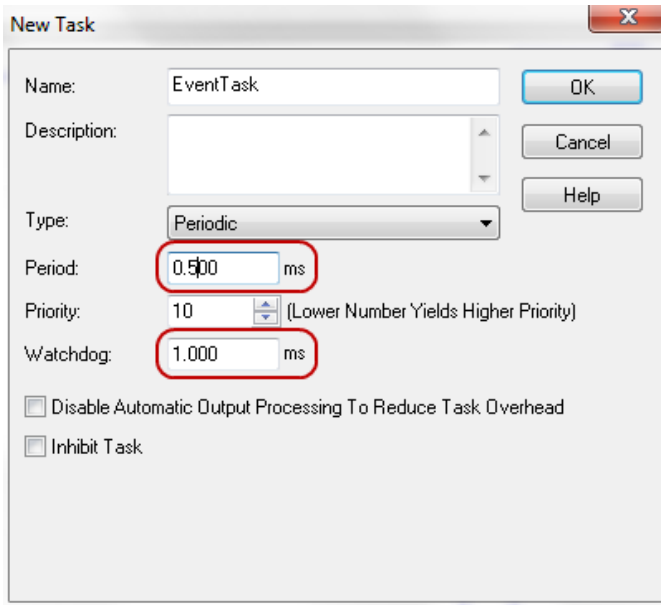

Ladder logic is written to monitor the Gocator's running state and store data into a FIFO (Ladder Element FFL) array of the same data type.

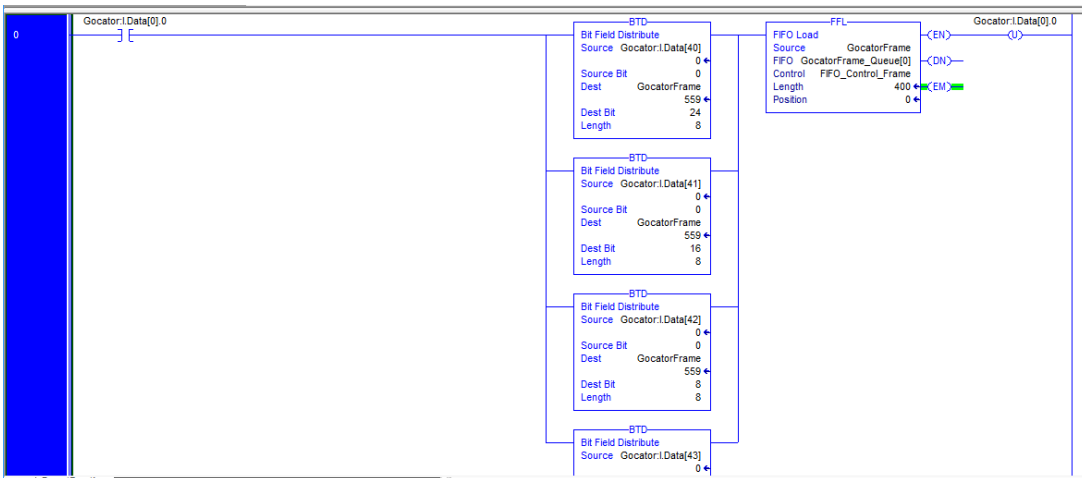

- b. Confirm that frames are properly stored in the stored array, without any repetition or dropped frames. In this case, the Gocator frame count is stored in a user-defined array.

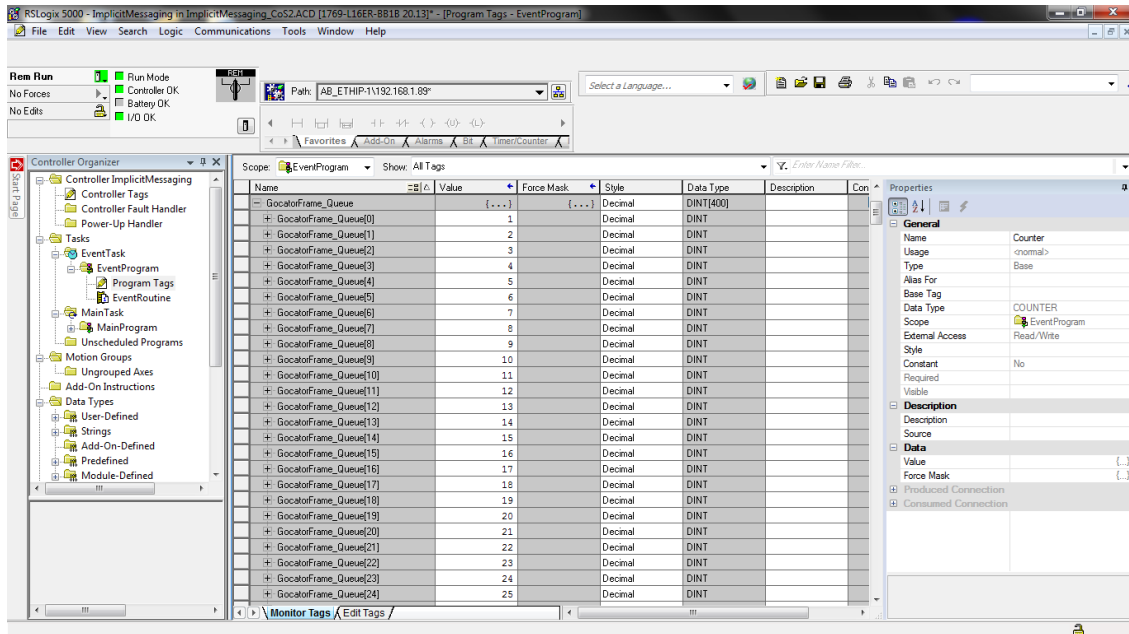

Using the Implicit Messaging Gocator Command Assembly

The Output Message format (from PLC to Gocator) is used to control the sensor through implicit messaging. This message is sent continuously from the PLC to the Gocator at the user-requested Request Packet Interval (RPI) on the PLC side. The default Gocator RPI is 10ms.

In PLC programming, the standard practice is to use bits instead of sending a value representing that command, for example, start/stop bits. When using values, the PLC needs to add more code to convert it to bits and vice versa.

Since the Gocator does not allow parallel commands, a priority scheme is needed to handle multiple command bits being set at the same time. Only the bit with the highest priority will be accepted as the command.

The total command message size is 32 bytes.

For information on the command assembly structure, see *Implicit Messaging Command Assembly* on page 416.

It's important to understand that because the Gocator is driven internally by its own clock, and because users can configure the Gocator for any frame rate—independently of the RPI request configured on the PLC—Cyclic implicit messaging can cause unnecessary data loss if the two clocks are not synchronized. Using Change of State implicit messaging instead can overcome this issue. For instructions on how to set up Change of State implicit messaging, see [Setting Up Change of State Implicit Messaging](#).

The data block used to send control messages to the Gocator should have been set properly up in *Setting Up Implicit Messaging on the PLC* on page 422. It will appear in the Gocator Module-Defined data types as shown below:

Name	Data Type
Command	SINT
Reserved_or_Job_File1	SINT
Reserved_or_Job_File2	SINT
Reserved_or_Job_File3	SINT
Reserved_or_Job_File4	SINT
Reserved_or_Job_File5	SINT
Reserved_or_Job_File6	SINT
Reserved_or_Job_File7	SINT
Reserved_or_Job_File8	SINT
Reserved_or_Job_File9	SINT
Reserved_or_Job_File10	SINT
Reserved_or_Job_File11	SINT
Reserved_or_Job_File12	SINT
Reserved_or_Job_File13	SINT
Reserved_or_Job_File14	SINT
Reserved_or_Job_File15	SINT
Reserved_or_Job_File16	SINT
Reserved_or_Job_File17	SINT
Reserved_or_Job_File18	SINT
Reserved_or_Job_File19	SINT
Reserved_or_Job_File20	SINT
Reserved_or_Job_File21	SINT
Reserved_or_Job_File22	SINT
Reserved_or_Job_File23	SINT
Reserved_or_Job_File24	SINT
Reserved_or_Job_File25	SINT
Reserved_or_Job_File26	SINT
Reserved_or_Job_File27	SINT
Reserved_or_Job_File28	SINT
Reserved_or_Job_File29	SINT
Reserved_or_Job_File30	SINT
Reserved_or_Job_File31	SINT

Starting a Sensor

To start a sensor, do the following:

1. Make sure that you have downloaded your PLC program to the controller and that your controller is in Run mode.

For information on downloading the the PLC program to the controller, see *Install EDS File* on page 422.

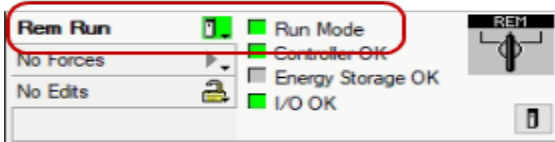

2. In the Controller Organizer, double-click **Controller Tags** to show them in the main screen

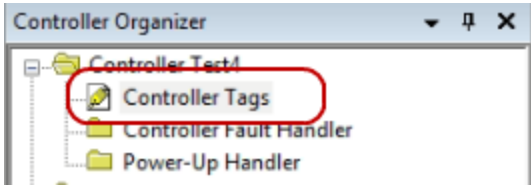

3. Click your Output data block to expand

Name	Value	Force Mask	Style	Data Type
+ Gocator1:I	{...}	{...}		_04E8:GXXXX_E3AB977D:I:0
+ Gocator1:O	{...}	{...}		_04E8:GXXXX_F45C457B:O:0
+ Local:1:C	{...}	{...}		AB:Embedded_DiscreteIO:C:0
+ Local:1:I	{...}	{...}		AB:Embedded_DiscreteIO:I:0
+ Local:1:O	{...}	{...}		AB:Embedded_DiscreteIO:O:0

4. Write the integer value 2 to the first byte named **Command**.

- Gocator1:0	{...}
+ Gocator1:0.Command	2
+ Gocator1:0.Reserved_or_Job_File1	0
+ Gocator1:0.Reserved_or_Job_File2	0
+ Gocator1:0.Reserved_or_Job_File3	0
+ Gocator1:0.Reserved_or_Job_File4	0
+ Gocator1:0.Reserved_or_Job_File5	0
+ Gocator1:0.Reserved_or_Job_File6	0
+ Gocator1:0.Reserved_or_Job_File7	0
+ Gocator1:0.Reserved_or_Job_File8	0
+ Gocator1:0.Reserved_or_Job_File9	0
+ Gocator1:0.Reserved_or_Job_File10	0
+ Gocator1:0.Reserved_or_Job_File11	0
+ Gocator1:0.Reserved_or_Job_File12	0
+ Gocator1:0.Reserved_or_Job_File13	0
+ Gocator1:0.Reserved_or_Job_File14	0
+ Gocator1:0.Reserved_or_Job_File15	0
+ Gocator1:0.Reserved_or_Job_File16	0
+ Gocator1:0.Reserved_or_Job_File17	0
+ Gocator1:0.Reserved_or_Job_File18	0
+ Gocator1:0.Reserved_or_Job_File19	0
+ Gocator1:0.Reserved_or_Job_File20	0
+ Gocator1:0.Reserved_or_Job_File21	0
+ Gocator1:0.Reserved_or_Job_File22	0
+ Gocator1:0.Reserved_or_Job_File23	0
+ Gocator1:0.Reserved_or_Job_File24	0
+ Gocator1:0.Reserved_or_Job_File25	0
+ Gocator1:0.Reserved_or_Job_File26	0
+ Gocator1:0.Reserved_or_Job_File27	0
+ Gocator1:0.Reserved_or_Job_File28	0
+ Gocator1:0.Reserved_or_Job_File29	0
+ Gocator1:0.Reserved_or_Job_File30	0
+ Gocator1:0.Reserved_or_Job_File31	0

- Go to a web browser and type in the sensor IP address to the URL bar. This should load the web GUI

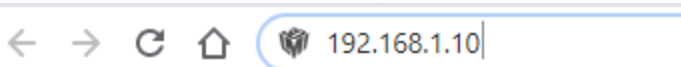

- Verify that the sensor started.

If the Run button is a red square, then the sensor was successfully started.



This process can be repeated to stop the sensor, clear alignment, start moving alignment, start stationary alignment, or issue a software trigger by typing the proper integer value into the Command byte of the

Output assembly. For additional commands and control options, *Implicit Messaging Command Assembly* on page 416, or refer to the provided sample Studio 5000 job file.

Loading a Sensor Job File

1. Make sure that you have downloaded your PLC program to the controller and that your controller is in Run mode.

For information on downloading the the PLC program to the controller, see *Install EDS File* on page 422.

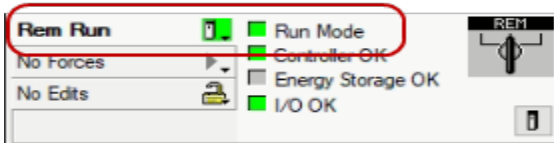

2. Double click **Controller Tags** to show them in the main screen

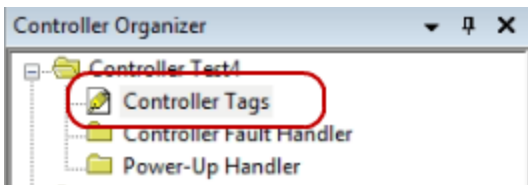

3. Click your Output data block to expand

Name	Value	Force Mask	Style	Data Type
+ Gocator1:I	{...}	{...}		_04E8:GXXXX_E3AB977D:I:0
+ Gocator1:O	{...}	{...}		_04E8:GXXXX_F45C457B:O:0
+ Local:1:C	{...}	{...}		AB:Embedded_DiscreteIO:C:0
+ Local:1:I	{...}	{...}		AB:Embedded_DiscreteIO:I:0
+ Local:1:O	{...}	{...}		AB:Embedded_DiscreteIO:O:0

4. If 1.job is the name of the job file to be loaded on the sensor and it is not currently running, type each of the five characters making up the filename into the first five characters of the Reserved bytes of the Command assembly.

The ASCII character inputs here are case sensitive and the extension, .job, must be included. All non-jobname characters must be null or empty values. Changing the display option from Decimal (which is the default) to ASCII can make this easier.

Gocator:O		(...)	{...}
+ Gocator:O.Command	0		Decimal
+ Gocator:O.Reserved_or_Job_File1	'1'		ASCII
+ Gocator:O.Reserved_or_Job_File2	'.'		ASCII
+ Gocator:O.Reserved_or_Job_File3	'j'		ASCII
+ Gocator:O.Reserved_or_Job_File4	'o'		ASCII
+ Gocator:O.Reserved_or_Job_File5	'b'		ASCII
+ Gocator:O.Reserved_or_Job_File6	'\$00'		ASCII
+ Gocator:O.Reserved_or_Job_File7	'\$00'		ASCII
+ Gocator:O.Reserved_or_Job_File8	'\$00'		ASCII
+ Gocator:O.Reserved_or_Job_File9	'\$00'		ASCII
+ Gocator:O.Reserved_or_Job_File10	'\$00'		ASCII
+ Gocator:O.Reserved_or_Job_File11	'\$00'		ASCII
+ Gocator:O.Reserved_or_Job_File12	'\$00'		ASCII
+ Gocator:O.Reserved_or_Job_File13	'\$00'		ASCII
+ Gocator:O.Reserved_or_Job_File14	'\$00'		ASCII
+ Gocator:O.Reserved_or_Job_File15	'\$00'		ASCII
+ Gocator:O.Reserved_or_Job_File16	'\$00'		ASCII
+ Gocator:O.Reserved_or_Job_File17	'\$00'		ASCII
+ Gocator:O.Reserved_or_Job_File18	'\$00'		ASCII
+ Gocator:O.Reserved_or_Job_File19	'\$00'		ASCII
+ Gocator:O.Reserved_or_Job_File20	'\$00'		ASCII
+ Gocator:O.Reserved_or_Job_File21	'\$00'		ASCII
+ Gocator:O.Reserved_or_Job_File22	'\$00'		ASCII
+ Gocator:O.Reserved_or_Job_File23	'\$00'		ASCII
+ Gocator:O.Reserved_or_Job_File24	'\$00'		ASCII
+ Gocator:O.Reserved_or_Job_File25	'\$00'		ASCII
+ Gocator:O.Reserved_or_Job_File26	'\$00'		ASCII
+ Gocator:O.Reserved_or_Job_File27	'\$00'		ASCII
+ Gocator:O.Reserved_or_Job_File28	'\$00'		ASCII
+ Gocator:O.Reserved_or_Job_File29	'\$00'		ASCII
+ Gocator:O.Reserved_or_Job_File30	'\$00'		ASCII
+ Gocator:O.Reserved_or_Job_File31	'\$00'		ASCII

- Then type the integer value 64 into the **Command** byte to transmit the job name for loading.

Gocator:O		(...)	{...}
+ Gocator:O.Command	64		Decimal
+ Gocator:O.Reserved_or_Job_File1	'1'		ASCII
+ Gocator:O.Reserved_or_Job_File2	'.'		ASCII
+ Gocator:O.Reserved_or_Job_File3	'j'		ASCII
+ Gocator:O.Reserved_or_Job_File4	'o'		ASCII
+ Gocator:O.Reserved_or_Job_File5	'b'		ASCII
+ Gocator:O.Reserved_or_Job_File6	'\$00'		ASCII
+ Gocator:O.Reserved_or_Job_File7	'\$00'		ASCII
+ Gocator:O.Reserved_or_Job_File8	'\$00'		ASCII

- Go to a web browser and type in the sensor IP address to the URL bar

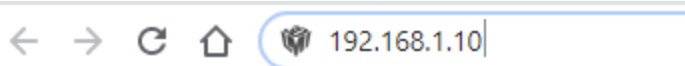

- Once the web GUI loads, verify that the job was loaded on the Gocator by looking at the job name box

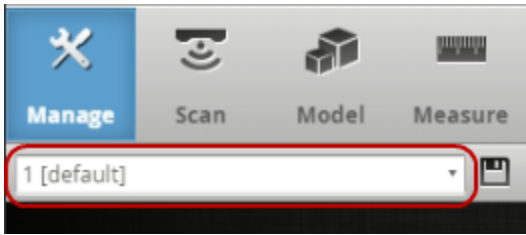

This process can be repeated to load runtime variables by typing the proper integer value into the Command byte of the Output assembly after preloading the runtime variable values into four successive bytes starting at byte 4 of the Reserved bytes. For additional commands and control options, *Implicit Messaging Command Assembly* on page 416, or refer to the provided sample Studio 5000 job file.

Setting Up Explicit Messaging on the Gocator

To output in Ethernet/IP explicit messaging mode on the sensor, you configure the sensor using the **Protocol** setting and the **Configuration** area on the **Output** page.

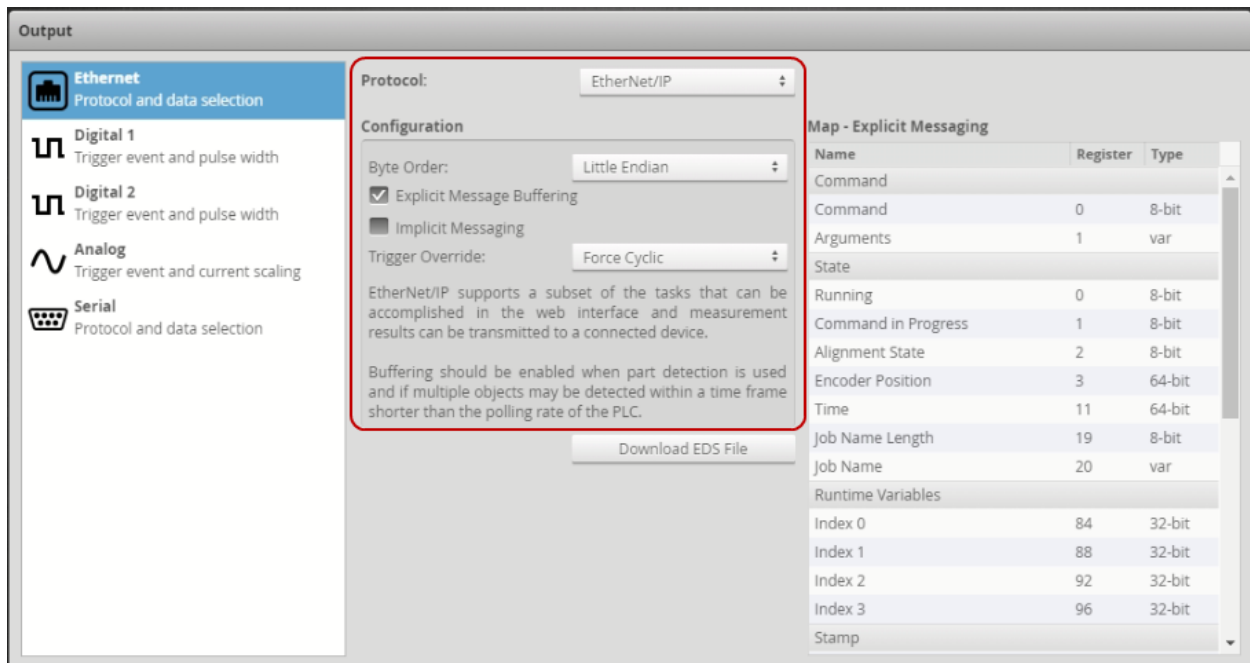

To configure the sensor for Ethernet/IP explicit messaging mode:

- On the **Output** page, in the **Ethernet** category, choose **EtherNet/IP** as the protocol.
- Choose **Little Endian** from the **Byte Order** dropdown box.
- Check the **Explicit Message Buffering** option.
- Make sure that **Implicit Messaging** is unchecked.

Reading Single Attribute on the PLC (Explicit Messaging)

This section shows how to read the serial number from a Gocator sensor, that is, attribute 6. (For more on the Identity Object, see *Identity Object (Class 0x01)* on page 410.)

Before attempting to control and run the Gocator from the PLC, you should always verify the connection first by reading an attribute from the Identity Object, for example the sensor's serial number. LMI recommends following the steps described in this section before trying to control the sensor.

To read the sensor's serial number:

1. In Studio 5000, in the Controller Organizer, expand **Controller Tags** by double-clicking it.

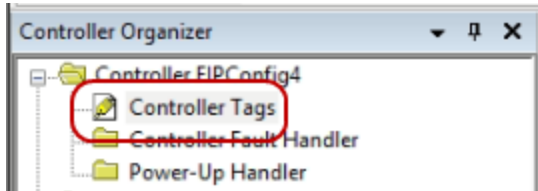

2. Right-click in the middle of the screen and choose **New Tag** from the context menu.

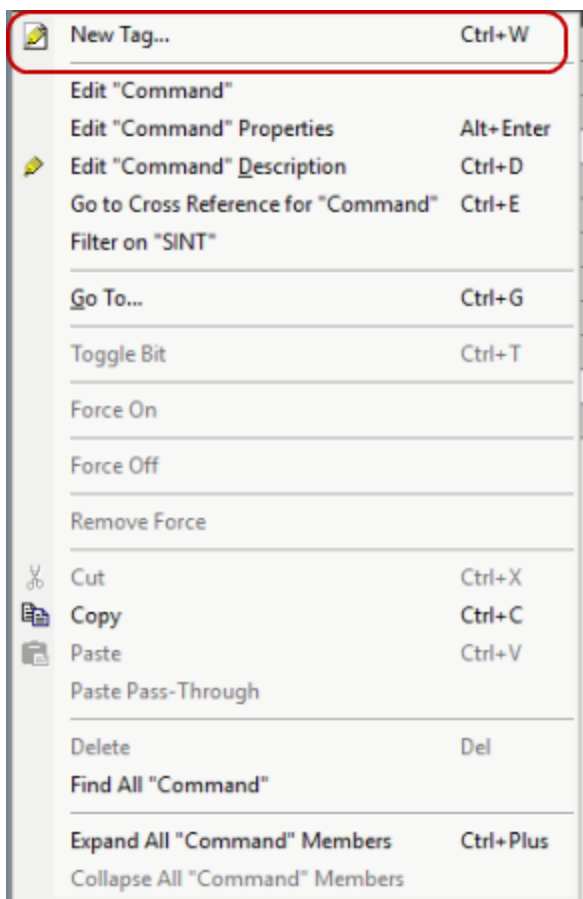

3. In the New Tag dialog, change the data type to MESSAGE.
This creates a block to store parameters for requesting data from the Gocator.

The 'New Tag' dialog box is shown with the following fields and options:

- Name: [Empty text box]
- Description: [Empty text area]
- Type: Base (dropdown), Connection... (button)
- Alias For: [Empty dropdown]
- Data Type: MESSAGE (dropdown, highlighted with a red circle)
- Scope: EIPConfig4 (dropdown)
- External Access: Read/Write (dropdown)
- Style: [Empty dropdown]
- Constant
- Open MESSAGE Configuration
- Buttons: Create (dropdown), Cancel, Help

4. Name the tag and click **Create** to the right.

The 'New Tag' dialog box is shown with the following fields and options:

- Name: SerialNumber (text box, highlighted with a red circle)
- Description: [Empty text area]
- Type: Base (dropdown), Connection... (button)
- Alias For: [Empty dropdown]
- Data Type: MESSAGE (dropdown)
- Scope: EIPConfig4 (dropdown)
- External Access: Read/Write (dropdown)
- Style: [Empty dropdown]
- Constant
- Open MESSAGE Configuration
- Buttons: Create (dropdown), Cancel, Help

5. Right-click in the middle of the screen again and choose **New Tag** from the context menu.
6. Change the data type to DINT and name the tag.

This will create a tag to store the serial number in. The type must match the data type of the attribute you want to get. To determine the type of the attribute, see *Identity Object (Class 0x01)* on page 410.

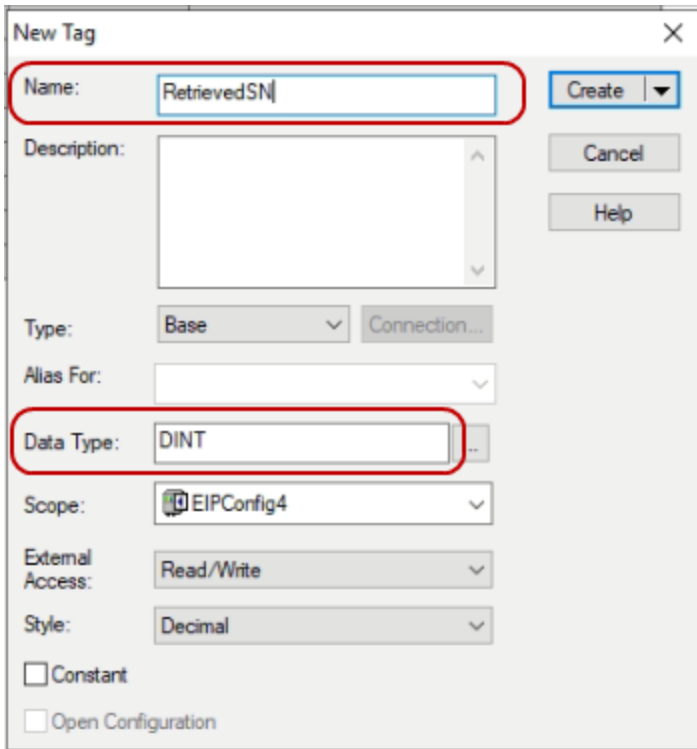

7. In the ladder, navigate to the Input/Output function blocks and click MSG to add a Message function block. You may need to add a new rung to allow this.



8. Once the new MSG function block has been added, click the tag dropdown and select the MSG tag you created earlier.



9. Click the grey box to open the Configuration Dialog box.

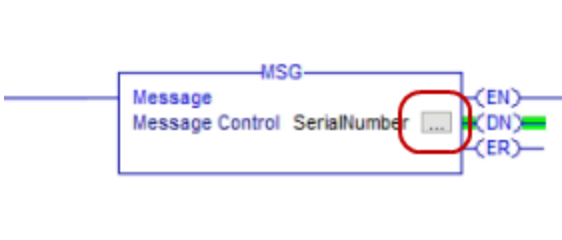

10. Choose the **Get Attribute Single** function from the **Service Type** dropdown.

This will auto-populate the Service Code hex character.

Message Configuration - SerialNumber

Configuration* Communication Tag

Message Type: CIP Generic

Service Type: Get Attribute Single

Source Element: []

Source Length: 0 (Bytes)

Destination Element: []

Service Code: e (Hex) Class: 1 (Hex)

Instance: 1 Attribute: 6 (Hex)

New Tag...

Enable Enable Waiting Start Done Done Length: 4

Error Code: Extended Error Code: Timed Out

Error Path:

Error Text:

OK Cancel Apply Help

11. Type 1 in **Class**, 1 in **Instance**, and 6 in **Attribute**.

These settings indicate that the sensor's serial number will be retrieved.

Message Configuration - SerialNumber

Configuration* Communication Tag

Message Type: CIP Generic

Service Type: Get Attribute Single

Source Element: []

Source Length: 0 (Bytes)

Destination Element: []

Service Code: e (Hex) Class: 1 (Hex)

Instance: 1 Attribute: 6 (Hex)

New Tag...

Enable Enable Waiting Start Done Done Length: 4

Error Code: Extended Error Code: Timed Out

Error Path:

Error Text:

OK Cancel Apply Help

12. Choose the DINT tag you created to store the serial number from the **Destination Element** dropdown.

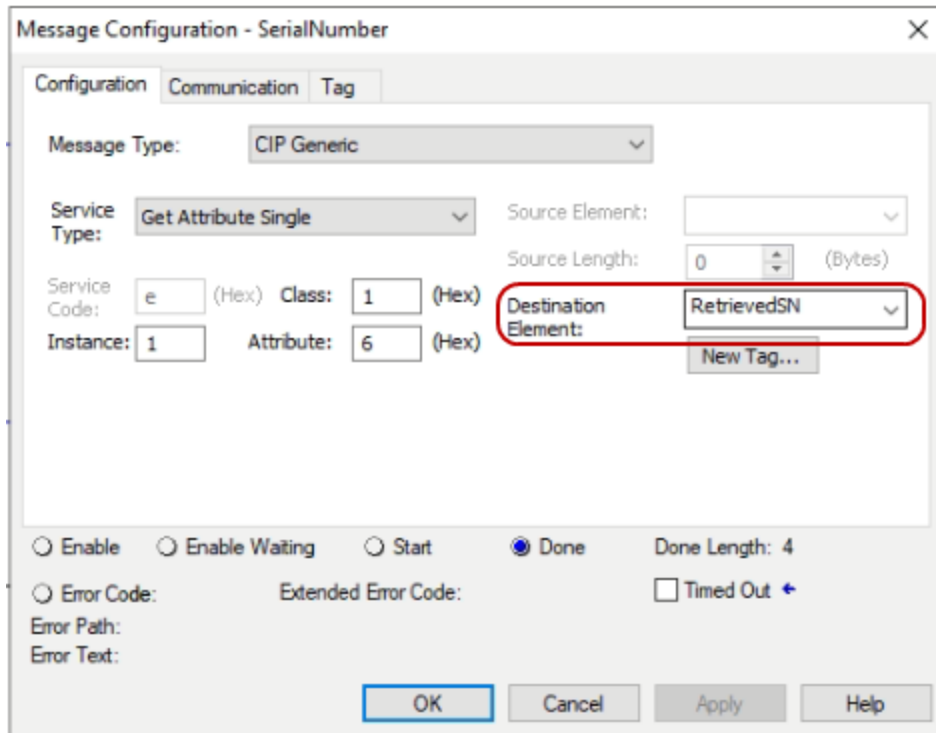

13. On the **Communication** tab, click **Browse**.

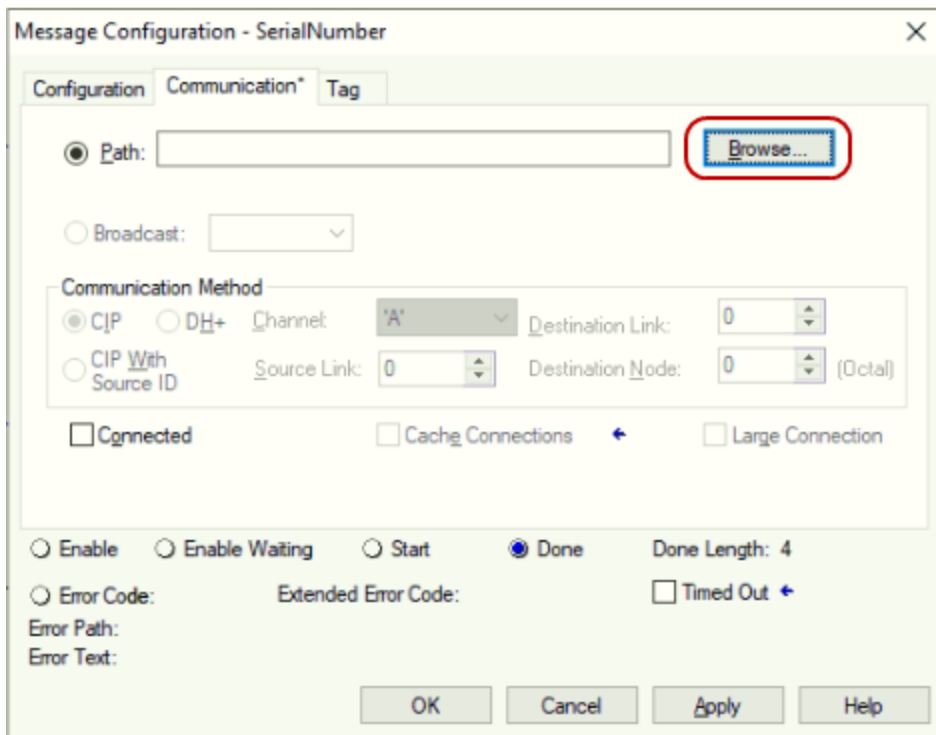

14. In the Message Path Browser dialog, choose the **EtherNet/IP Network** node.
This will route communication messages to the EtherNet/IP network.

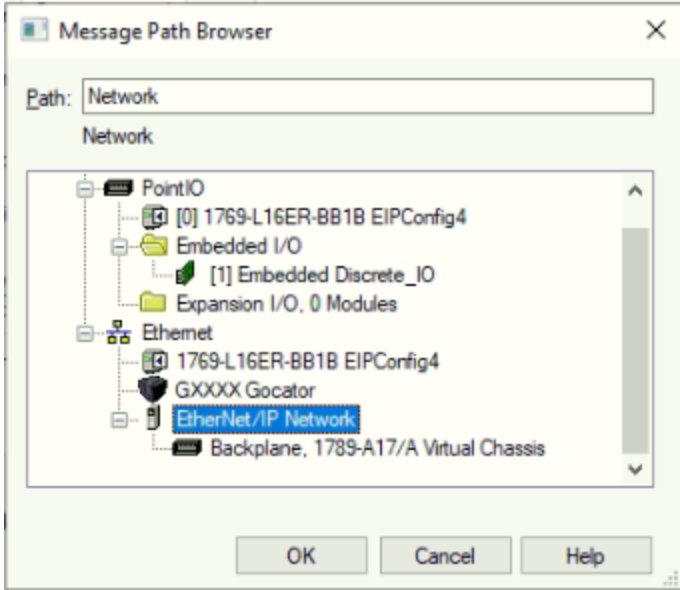

15. In **Path**, type the Ethernet port on the PLC that is physically connected to the Gocator, after the name in the field.

Here, the port “2” is added.

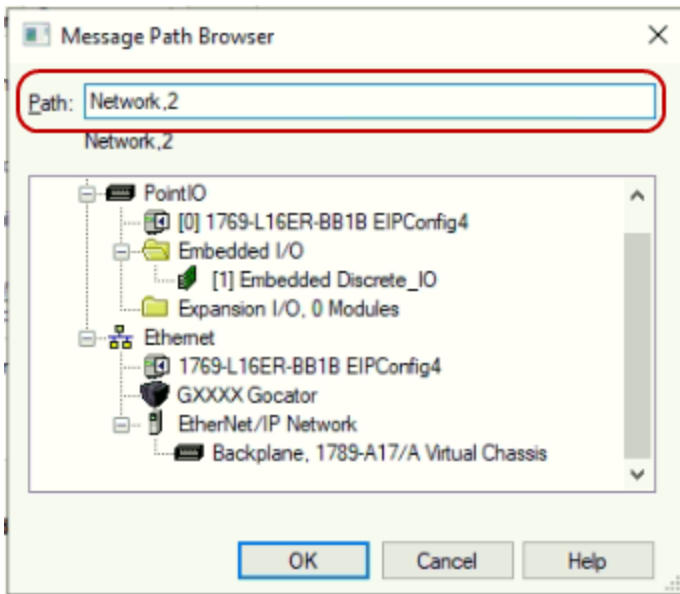

16. In **Path**, type the IP address of the Gocator to complete the path.

Double-check that the network, port, and IP address are separated by commas in the form “networkname,port,IPaddress”.

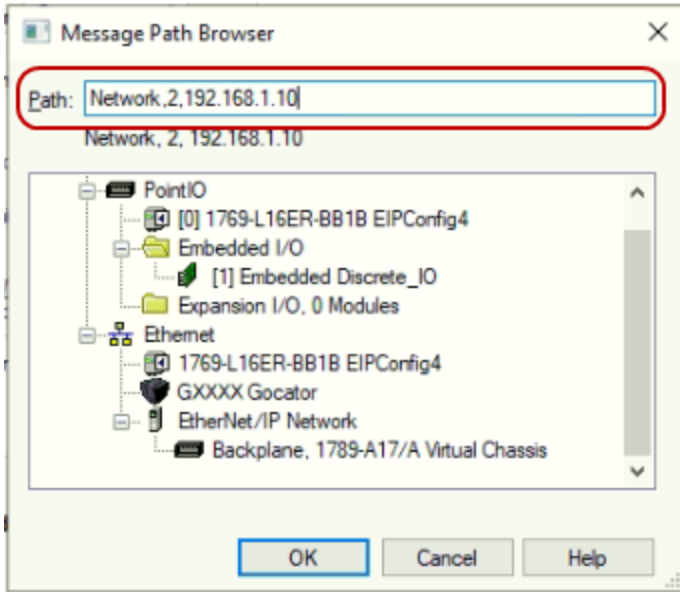

17. Click **OK** to exit the Message Path Browser dialog, and click **OK** again to exit the Message Configuration dialog.

18. In the Controller Organizer, verify that the serial number is updated in the RetrievedSN tag by going to the Controller Tags node.

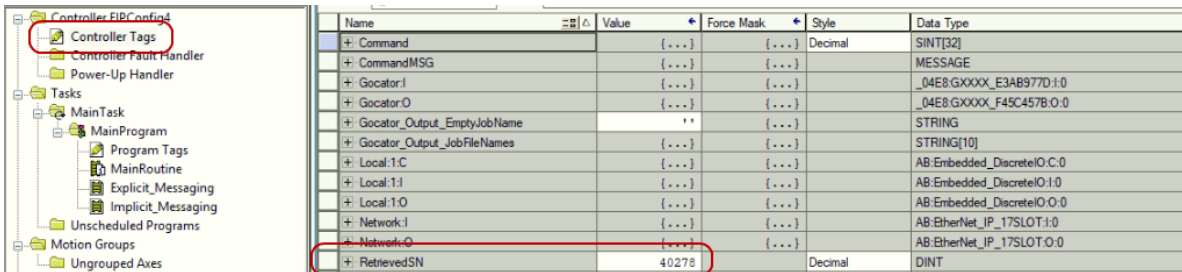

To obtain a measurement result, use the procedure described above but change the messaging block class to 4, the instance to 801, and the attribute to 3. The data storage location for this attribute will have to be the proper type and length; for more information, see *Sensor State Assembly* on page 413. You will now have to create ladder logic to copy the correct bits in the raw data stream into Controller Tags holding the individual results. This can be done with the Bit Field Distribute (BTD) block. For

Setting Single Attribute to Gocator on the PLC (Explicit Messaging)

You use the Command assembly to do the following:

- Start a sensor
- Stop a sensor
- Align a sensor
- Clear sensor alignment
- Set a sensor's runtime variables
- Load a job on a sensor
- Trigger a sensor

To see the information needed to properly configure the control byte, see *Command Assembly* on page 411.

 LMI recommends following the steps in *To read the sensor's serial number:* on page 446 to verify the communication path and message block *before* attempting to control a sensor.

To set a single attribute to the sensor on the PLC, do the following:

1. In Studio 5000, in the Controller Organizer, expand Controller Tags by double-clicking it.

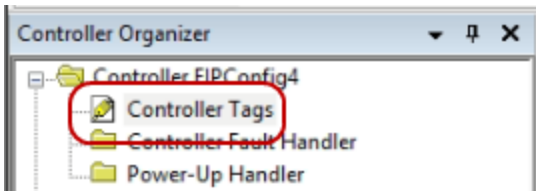

2. Right-click in the middle of the screen and select **New Tag** from the context menu.

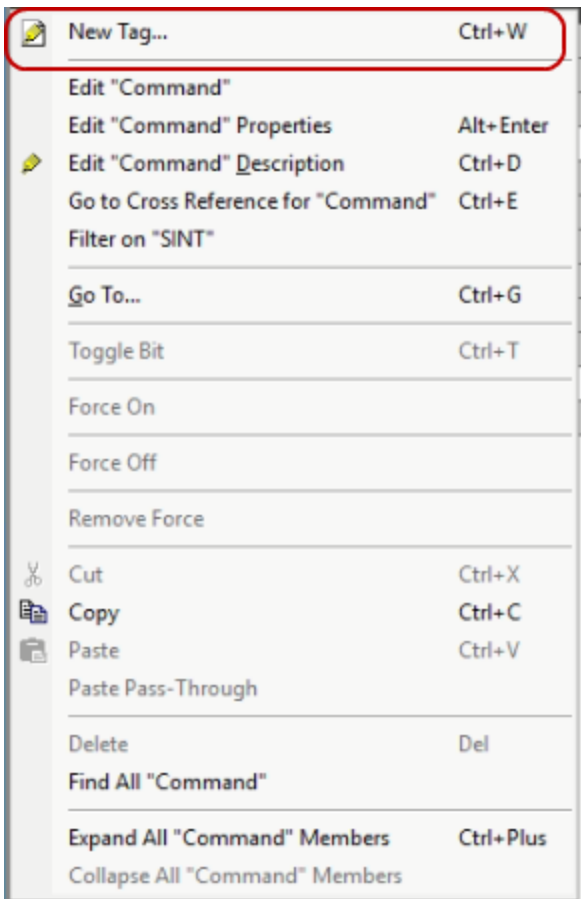

3. Change the data type to MESSAGE.

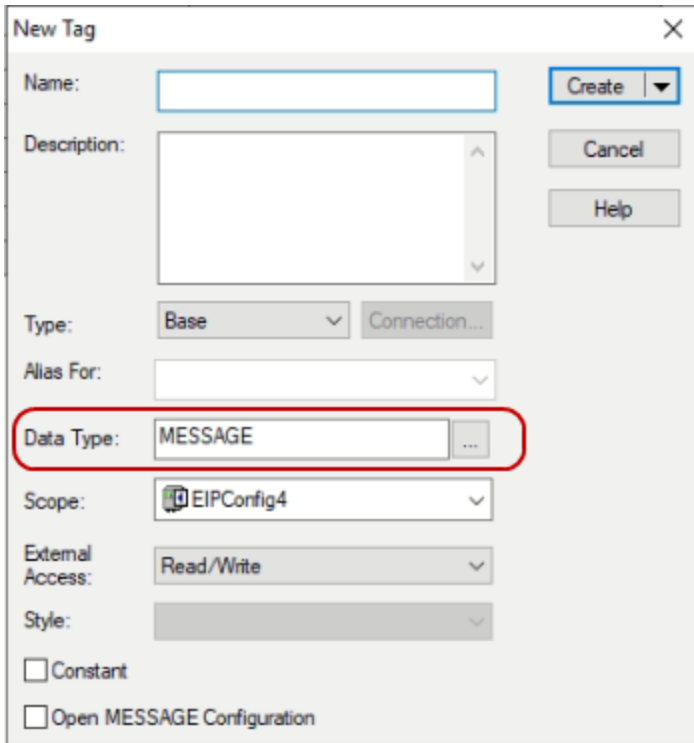

4. Name the tag and click Create.

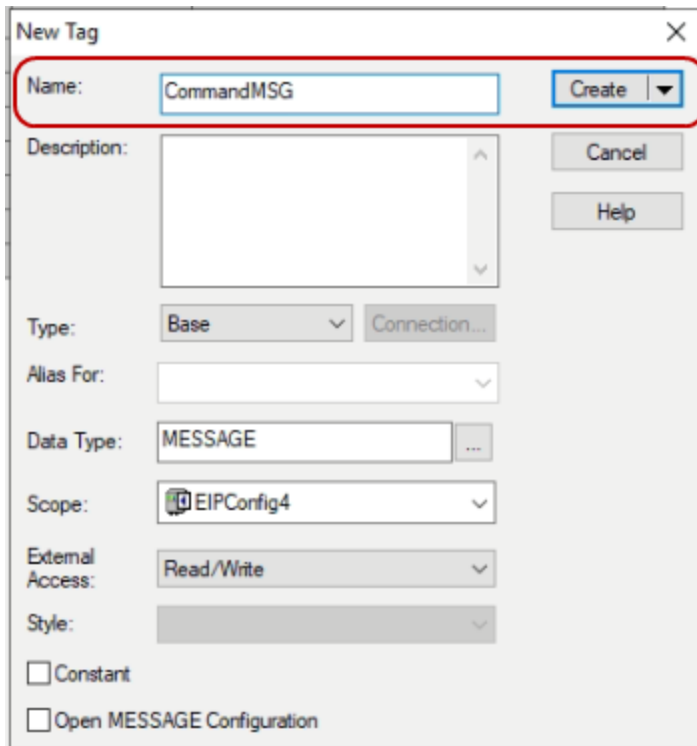

This creates a block to store parameters for sending data to the Gocator.

5. Right-click in the middle of the screen *again* and choose **New Tag** from the context menu.

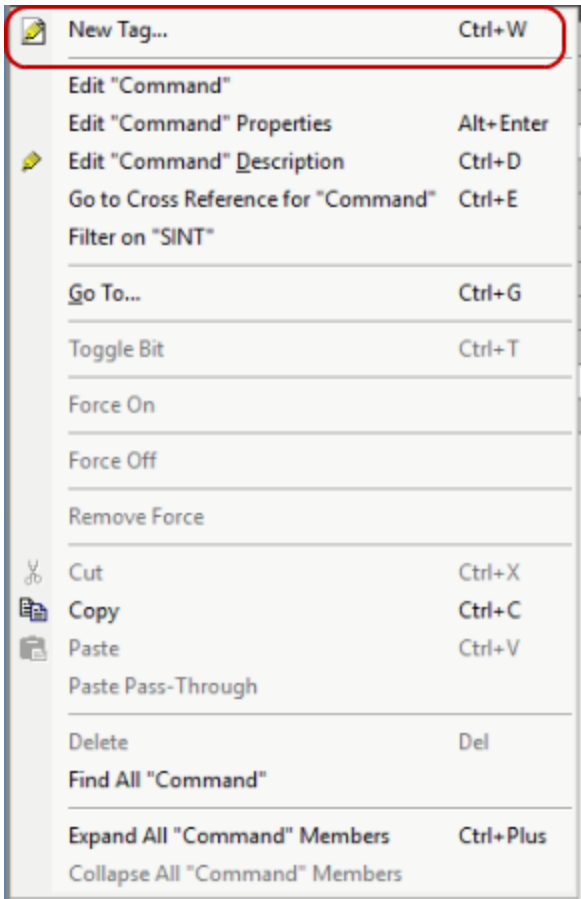

6. Change the data type to SINT[32] and name the tag.

The 'New Tag' dialog box is shown with the following settings:

- Name: Command
- Description: (empty text area)
- Type: Base
- Alias For: (empty dropdown)
- Data Type: SINT[32]
- Scope: EIPConfig4
- External Access: Read/Write
- Style: Decimal
- Constant:
- Open Configuration:

- Set Style to one of the following:

If you will be loading job files on the Gocator over the protocol, change **Style** from the default to **ASCII**. This will make editing the command assembly easier later.

The 'New Tag' dialog box is shown with the following settings:

- Name: Command
- Description: (empty text area)
- Type: Base
- Alias For: (empty dropdown)
- Data Type: SINT[32]
- Scope: EIPConfig4
- External Access: Read/Write
- Style: ASCII
- Constant:
- Open Configuration:

If you will only be starting or stopping the sensor, leave **Style** at the default setting of **Decimal**.

8. Click **Create**.

This creates a tag to store the command data before sending it.

9. In the ladder, navigate to the Input/Output function blocks and click MSG to add a Message function block.

You may need to add a new rung to allow this.

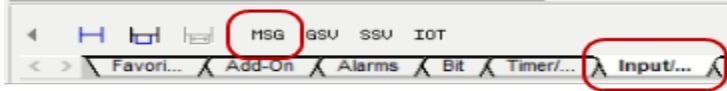

10. Once the new MSG function block has been added, click the tag dropdown and select the MSG tag you created earlier.



11. Click the grey box to open the Configuration Dialog box



12. In the Message Configuration dialog, choose the **Set Attribute Single** function from the **Service Type** drop-down.

This will auto populate the Service Code hex character.

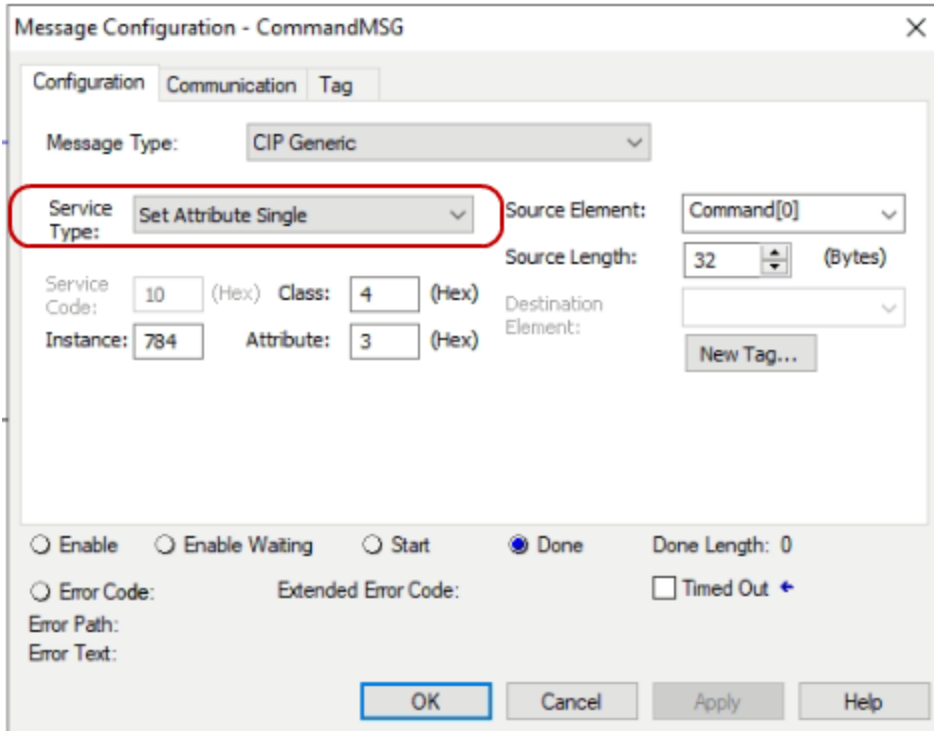

13. Enter 4 for Class, 784 for Instance, and 3 for Attribute to set the sensor's command assembly.

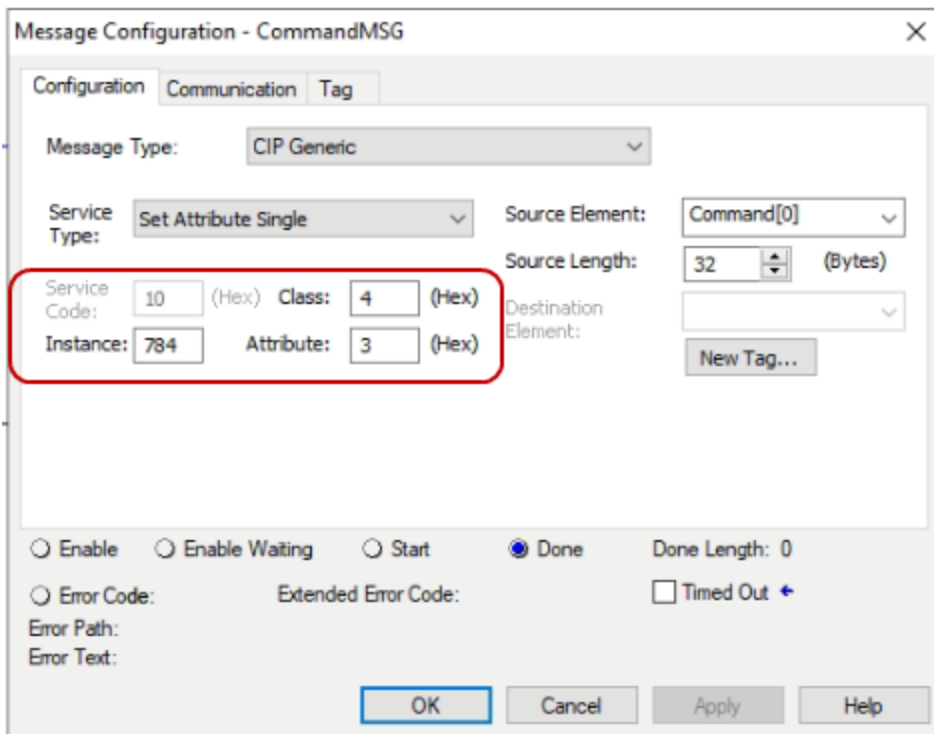

14. Select the SINT[32] tag you created to store the command assembly from the Destination Element dropdown

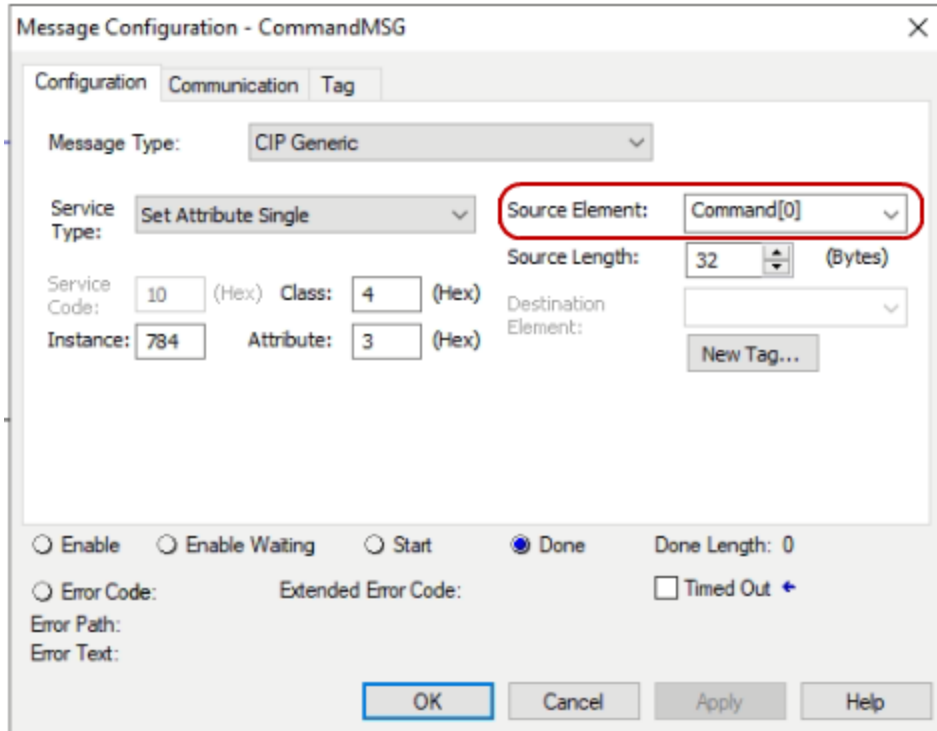

15. Make sure that the length is set to 32 bytes so that the entire command assembly is transmitted. A partial transmission may result in an unexecuted command.

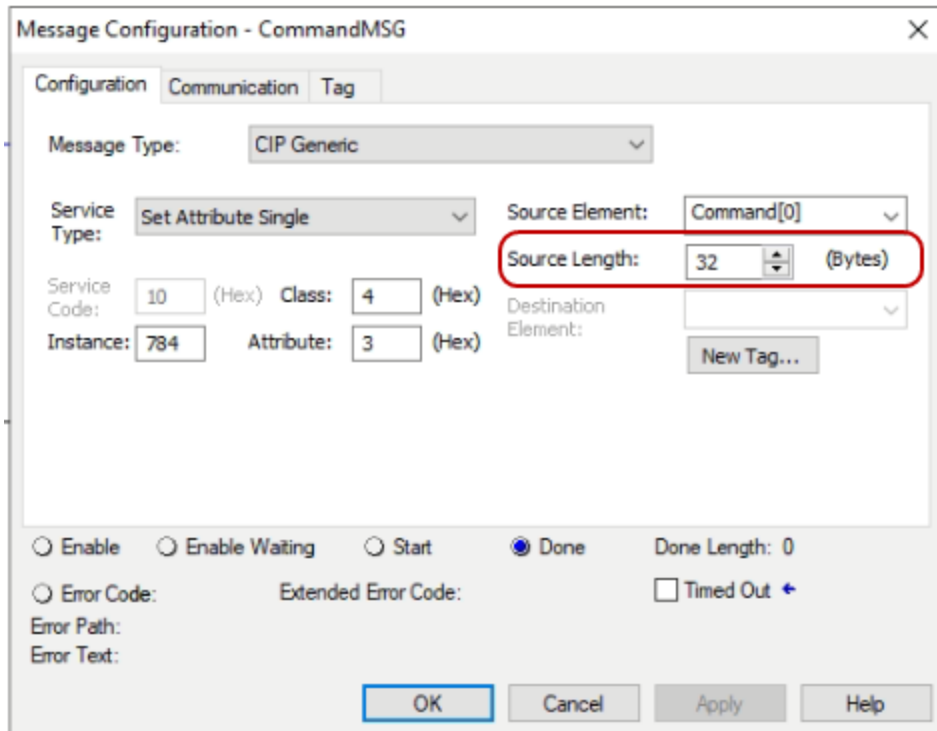

16. On the **Communication** tab, click **Browse**

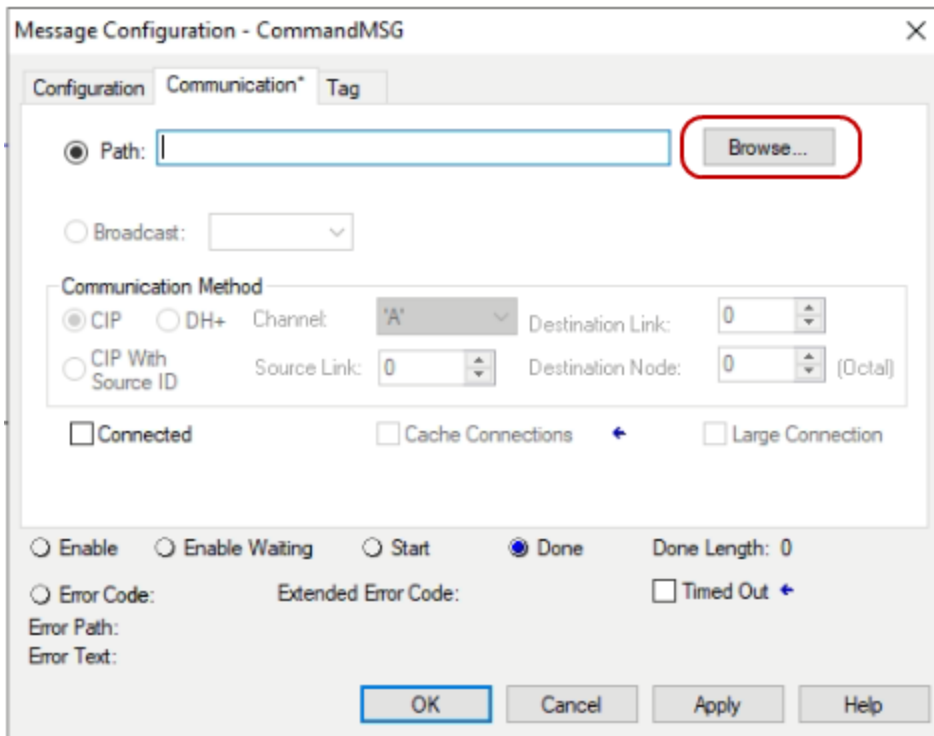

17. Click the **EtherNet/IP Network** node.

This will route communication messages to the EtherNet/IP network.

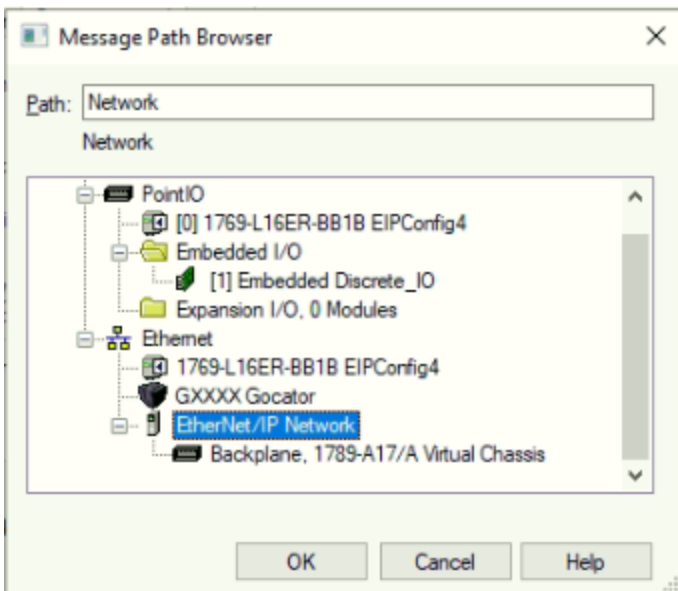

18. Add the ethernet port that is physically connected to the Gocator.

This will add the specific port address to your communication path.

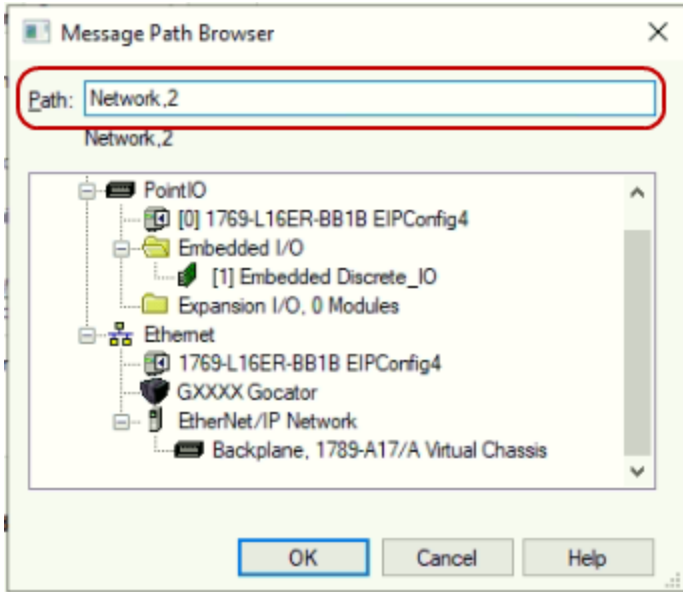

19. Type the IP address of the Gocator to complete the path.

It is important to double-check that the network, port, and IP address are separated by commas in the form “networkname,port,IPaddress”.

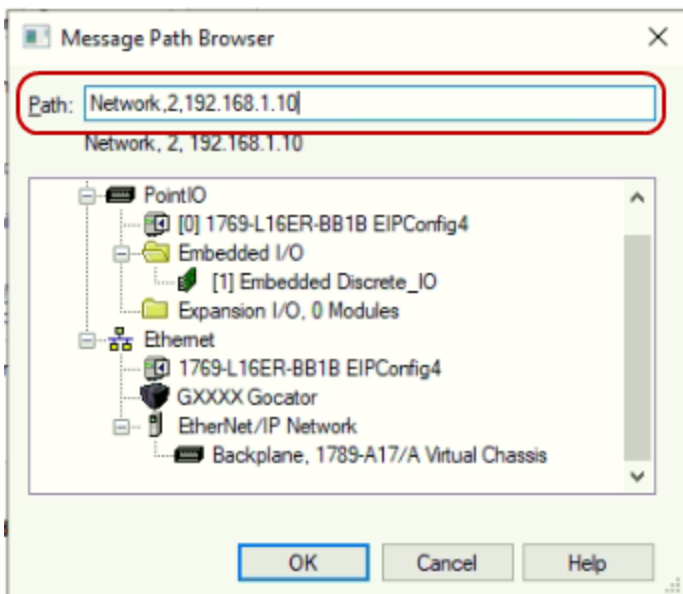

20. Click **OK**.

21. Click **OK** to exit the Message Configuration dialog.

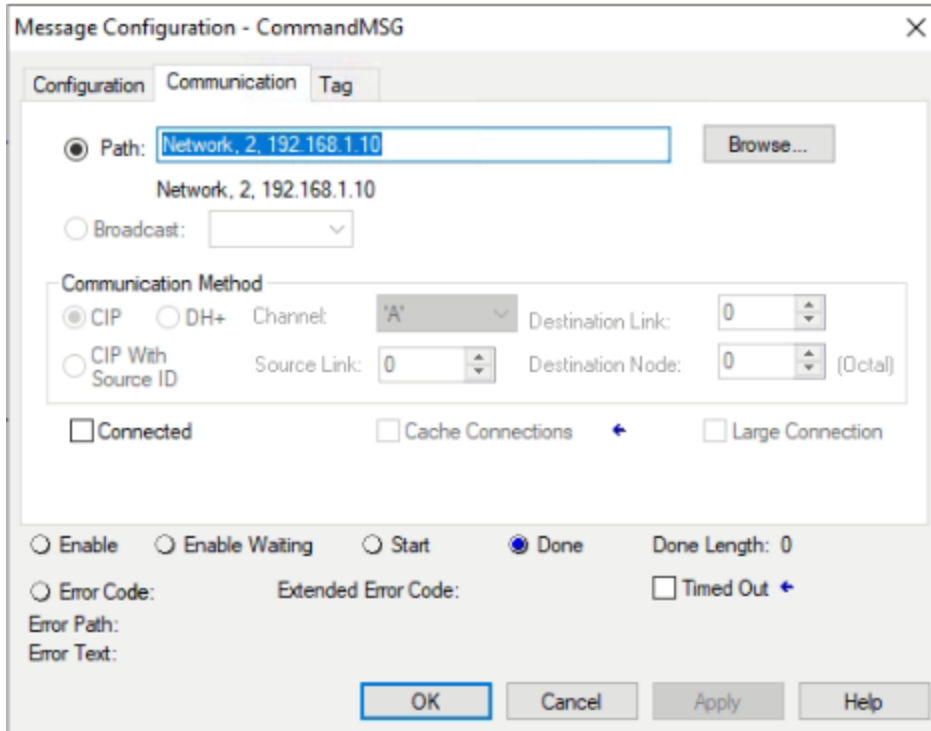

To start a sensor over explicit messaging, the Command assembly must be correctly modified for the integer-based command byte.

1. Make sure that you have downloaded your PLC program to the controller and that your controller is in Run Mode.

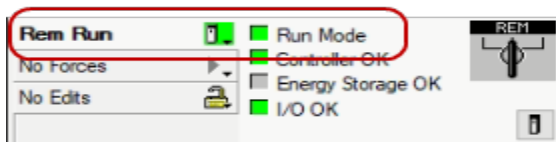

2. Expand Controller Tags by double-clicking it.

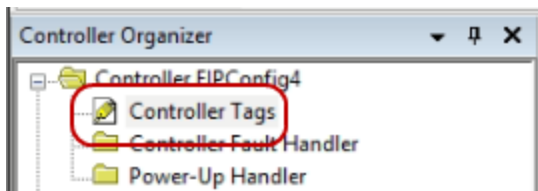

3. Expand the Command assembly tag.

Name	Value	Force Mask	Style	Data Type
- Command	[...]	[...]	ASCII	SINT[32]
+ Command[0]	'\$00'		ASCII	SINT
+ Command[1]	'\$00'		ASCII	SINT
+ Command[2]	'\$00'		ASCII	SINT
+ Command[3]	'\$00'		ASCII	SINT
+ Command[4]	'\$00'		ASCII	SINT
+ Command[5]	'\$00'		ASCII	SINT
+ Command[6]	'\$00'		ASCII	SINT
+ Command[7]	'\$00'		ASCII	SINT
+ Command[8]	'\$00'		ASCII	SINT
+ Command[9]	'\$00'		ASCII	SINT
+ Command[10]	'\$00'		ASCII	SINT
+ Command[11]	'\$00'		ASCII	SINT
+ Command[12]	'\$00'		ASCII	SINT
+ Command[13]	'\$00'		ASCII	SINT
+ Command[14]	'\$00'		ASCII	SINT
+ Command[15]	'\$00'		ASCII	SINT
+ Command[16]	'\$00'		ASCII	SINT
+ Command[17]	'\$00'		ASCII	SINT
+ Command[18]	'\$00'		ASCII	SINT
+ Command[19]	'\$00'		ASCII	SINT
+ Command[20]	'\$00'		ASCII	SINT
+ Command[21]	'\$00'		ASCII	SINT
+ Command[22]	'\$00'		ASCII	SINT
+ Command[23]	'\$00'		ASCII	SINT
+ Command[24]	'\$00'		ASCII	SINT
+ Command[25]	'\$00'		ASCII	SINT
+ Command[26]	'\$00'		ASCII	SINT
+ Command[27]	'\$00'		ASCII	SINT
+ Command[28]	'\$00'		ASCII	SINT
+ Command[29]	'\$00'		ASCII	SINT
+ Command[30]	'\$00'		ASCII	SINT
+ Command[31]	'\$00'		ASCII	SINT

If you changed the formatting of the Command tag array to ASCII, then change the display of only the first byte, Command[0], back to Decimal as the control command are sent as integer-based values.

- Command	[...]	[...]	ASCII	SINT[32]
+ Command[0]	0		Decimal	SINT
+ Command[1]	'\$00'		ASCII	SINT
+ Command[2]	'\$00'		ASCII	SINT

4. Type the number 1 into the value field of Command[0].

- Command	[...]	[...]	ASCII	SINT[32]
+ Command[0]	1		Decimal	SINT
+ Command[1]	'\$00'		ASCII	SINT
+ Command[2]	'\$00'		ASCII	SINT
+ Command[3]	'\$00'		ASCII	SINT
+ Command[4]	'\$00'		ASCII	SINT

5. Go to a web browser and type in the sensor IP address to the URL bar. This should load the web GUI



6. Verify that the sensor started.

If the Run button is a red square, then the sensor was successfully started.



Your ladder logic should only be able to edit the Command assembly 1 time. Since Explicit Message Buffering is checked from the Gocator setup, multiple message transfers from improper ladder logic will end up buffering on the Gocator side of the network. The only way to easily clear the messaging buffer is to power cycle the sensor.

Loading a Sensor Job File

1. Make sure that you have downloaded your PLC program to the controller and that your controller is in Run Mode

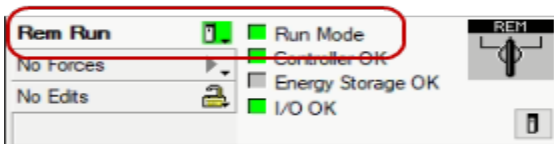

2. Expand **Controller Tags** by double-clicking it

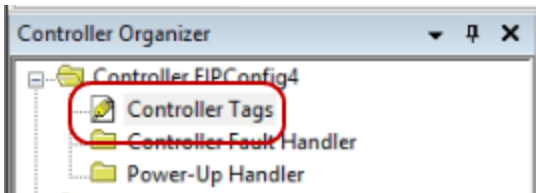

3. Expand the Command assembly tag

Name	Value	Force Mask	Style	Data Type
- Command	{...}	{...}	ASCII	SINT[32]
+ Command[0]	'\$00'		ASCII	SINT
+ Command[1]	'\$00'		ASCII	SINT
+ Command[2]	'\$00'		ASCII	SINT
+ Command[3]	'\$00'		ASCII	SINT
+ Command[4]	'\$00'		ASCII	SINT
+ Command[5]	'\$00'		ASCII	SINT
+ Command[6]	'\$00'		ASCII	SINT
+ Command[7]	'\$00'		ASCII	SINT
+ Command[8]	'\$00'		ASCII	SINT
+ Command[9]	'\$00'		ASCII	SINT
+ Command[10]	'\$00'		ASCII	SINT
+ Command[11]	'\$00'		ASCII	SINT
+ Command[12]	'\$00'		ASCII	SINT
+ Command[13]	'\$00'		ASCII	SINT
+ Command[14]	'\$00'		ASCII	SINT
+ Command[15]	'\$00'		ASCII	SINT
+ Command[16]	'\$00'		ASCII	SINT
+ Command[17]	'\$00'		ASCII	SINT
+ Command[18]	'\$00'		ASCII	SINT
+ Command[19]	'\$00'		ASCII	SINT
+ Command[20]	'\$00'		ASCII	SINT
+ Command[21]	'\$00'		ASCII	SINT
+ Command[22]	'\$00'		ASCII	SINT
+ Command[23]	'\$00'		ASCII	SINT
+ Command[24]	'\$00'		ASCII	SINT
+ Command[25]	'\$00'		ASCII	SINT
+ Command[26]	'\$00'		ASCII	SINT
+ Command[27]	'\$00'		ASCII	SINT
+ Command[28]	'\$00'		ASCII	SINT
+ Command[29]	'\$00'		ASCII	SINT
+ Command[30]	'\$00'		ASCII	SINT
+ Command[31]	'\$00'		ASCII	SINT

If you changed the formatting of the Command tag array to ASCII, then change the display of only the first byte, Command[0], back to Decimal as the control command are sent as integer-based values.

- Command	{...}	{...}	ASCII	SINT[32]
+ Command[0]	0		Decimal	SINT
+ Command[1]	'\$00'		ASCII	SINT
+ Command[2]	'\$00'		ASCII	SINT

4. If 1.job is the job file to be loaded on the sensor and it is not currently running, type each of the five characters making up the filename into Command[1] through Command[5] of the Command assembly.

The ASCII character inputs here are case sensitive and the extension, .job, must be included. All non-jobname characters must be null or empty values. If the style was changed to ASCII as the default during the tag creation, this will be done already, and the alphanumeric characters can be directly typed into the value column of the bytes.

Name	Value	Force Mask	Style	Data Type
[-] Command	{...}	{...}	ASCII	SINT[32]
[+] Command[0]	0		Decimal	SINT
[+] Command[1]	'1'		ASCII	SINT
[+] Command[2]	'.'		ASCII	SINT
[+] Command[3]	'j'		ASCII	SINT
[+] Command[4]	'o'		ASCII	SINT
[+] Command[5]	'b'		ASCII	SINT
[+] Command[6]	'\$00'		ASCII	SINT
[+] Command[7]	'\$00'		ASCII	SINT
[+] Command[8]	'\$00'		ASCII	SINT
[+] Command[9]	'\$00'		ASCII	SINT
[+] Command[10]	'\$00'		ASCII	SINT
[+] Command[11]	'\$00'		ASCII	SINT
[+] Command[12]	'\$00'		ASCII	SINT
[+] Command[13]	'\$00'		ASCII	SINT
[+] Command[14]	'\$00'		ASCII	SINT
[+] Command[15]	'\$00'		ASCII	SINT
[+] Command[16]	'\$00'		ASCII	SINT
[+] Command[17]	'\$00'		ASCII	SINT
[+] Command[18]	'\$00'		ASCII	SINT
[+] Command[19]	'\$00'		ASCII	SINT
[+] Command[20]	'\$00'		ASCII	SINT
[+] Command[21]	'\$00'		ASCII	SINT
[+] Command[22]	'\$00'		ASCII	SINT
[+] Command[23]	'\$00'		ASCII	SINT
[+] Command[24]	'\$00'		ASCII	SINT
[+] Command[25]	'\$00'		ASCII	SINT
[+] Command[26]	'\$00'		ASCII	SINT
[+] Command[27]	'\$00'		ASCII	SINT
[+] Command[28]	'\$00'		ASCII	SINT
[+] Command[29]	'\$00'		ASCII	SINT
[+] Command[30]	'\$00'		ASCII	SINT
[+] Command[31]	'\$00'		ASCII	SINT

- Type the integer value 64 into the Command byte to transmit the job name for loading.

Name	Value	Force Mask	Style
[-] Command	{...}	{...}	ASCII
[+] Command[0]	64		Decimal
[+] Command[1]	'1'		ASCII
[+] Command[2]	'.'		ASCII
[+] Command[3]	'j'		ASCII
[+] Command[4]	'o'		ASCII
[+] Command[5]	'b'		ASCII
[+] Command[6]	'\$00'		ASCII
[+] Command[7]	'\$00'		ASCII
[+] Command[8]	'\$00'		ASCII

- Go to a web browser and type in the sensor IP address to the URL bar.



- Once the web GUI loads, verify that the job was loaded on the Gocator by looking at the job name box.

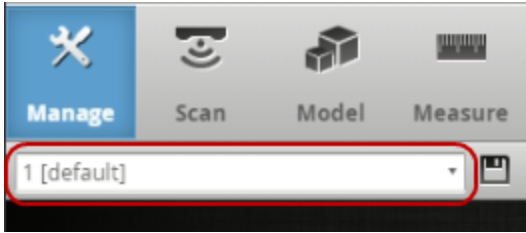

ASCII Protocol

This section describes the ASCII protocol.

The ASCII protocol is available over either serial output or Ethernet output. Over serial output, communication is asynchronous (measurement results are automatically sent on the Data channel when the sensor is in the running state and results become available). Over Ethernet, communication can be asynchronous or can use polling. For more information on polling commands, see *Polling Operation Commands (Ethernet Only)* on the next page.

The protocol communicates using ASCII strings. The output result format from the sensor is user-configurable.

To use the ASCII protocol, it must be enabled and configured in the active job.

The Gocator 4.x/5.x firmware uses mm, mm², mm³, and degrees as standard units. In all protocols, values are scaled by 1000, as values in the protocols are represented as integers. This results in effective units of mm/1000, mm²/1000, mm³/1000, and deg/1000 in the protocols.

For information on configuring the protocol with the Web interface (when using the protocol over Ethernet), see *Ethernet Output* on page 235.

For information on configuring the protocol with the Web interface (when using the protocol over Serial), see *Serial Output* on page 244.

Connection Settings

Ethernet Communication

With Ethernet ASCII output, you can set the connection port numbers of the three channels used for communication (Control, Data, and Health):

Ethernet Ports for ASCII

Name	Description	Default Port
Control	To send commands to control the sensor.	8190
Data	To retrieve measurement output.	8190
Health	To retrieve specific health indicator values.	8190

Channels can share the same port or operate on individual ports. The following port numbers are reserved for sensor internal use: 2016, 2017, 2018, and 2019. Each port can accept multiple connections, up to a total of 16 connections for all ports.

Serial Communication

Over serial, ASCII communication uses the following connection settings:

Serial Connection Settings for ASCII

Parameter	Value
Start Bits	1
Stop Bits	1
Parity	None
Data Bits	8
Baud Rate (b/s)	115200
Format	ASCII
Delimiter	CR

Up to 16 users can connect to the sensor for ASCII interfacing at a time. Any additional connections will remove the oldest connected user.

Polling Operation Commands (Ethernet Only)

On the Ethernet output, the Data channel can operate asynchronously or by polling.

Under asynchronous operation, measurement results are automatically sent on the Data channel when the sensor is in the running state and results become available. The result is sent on all connected data channels.

Under polling operation, a client can:

- Switch to a different job.
- Align, run, and trigger sensors.
- Receive sensor states, health indicators, stamps, and measurement results

A sensor sends Control, Data, and Health messages over separate channels. The Control channel is used for commands such as starting and stopping the sensor, loading jobs, and performing alignment (see *Command Channel* on the next page).

The Data channel is used to receive and poll for measurement results. When the sensor receives a [Result](#) command, it will send the latest measurement results on the same data channel that the request is received on. See *Data Channel* on page 473 for more information.

The Health channel is used to receive health indicators (see *Health Channel* on page 475).

Command and Reply Format

Commands are sent from the client to the sensor. Command strings are not case sensitive. The command format is:

<COMMAND><DELIMITER><PARAMETER><TERMINATION>

If a command has more than one parameter, each parameter is separated by the delimiter. Similarly, the reply has the following format:

<STATUS><DELIMITER><OPTIONAL RESULTS><DELIMITER>

The status can either be "OK" or "ERROR". The optional results can be relevant data for the command if successful, or a text based error message if the operation failed. If there is more than one data item, each item is separated by the delimiter.

The delimiter and termination characters are configured in the Special Character settings.

Special Characters

The ASCII Protocol has three special characters.

Special Characters

Special Character	Explanation
Delimiter	Separates input arguments in commands and replies, or data items in results. Default value is ",".
Terminator	Terminates both commands and result output. Default value is "%r%n".
Invalid	Represents invalid measurement results. Default value is "INVALID"

The values of the special characters are defined in the Special Character settings. In addition to normal ASCII characters, the special characters can also contain the following format values.

Format values for Special Characters

Format Value	Explanation
%t	Tab
%n	New line
%r	Carriage return
%%	Percentage (%) symbol

Command Channel

The following sections list the actions available on the command channel.

Optional parameters are shown in *italic*. The placeholder for data is surrounded by brackets (<>). In the examples, the delimiter is set to ','.

Start

The Start command starts the sensor system (causes it to enter the Running state). This command is only valid when the system is in the Ready state. If a start target is specified, the sensor starts at the target time or encoder (depending on the trigger mode).

Formats

Message	Format
Command	Start,start target The start target (optional) is the time or encoder position at which the sensor will be started. The time and encoder target value should be set by adding a delay to the time or encoder position returned by the Stamp command. The delay should be set such that it covers the command response time of the Start command.
Reply	OK or ERROR, <Error Message>

Examples:

```
Command: Start
Reply: OK
Command: Start,1000000
Reply: OK
Command: Start
Reply: ERROR, Could not start the sensor
```

Stop

The stop command stops the sensor system (causes it to enter the Ready state). This command is valid when the system is in the Ready or Running state.

Formats

Message	Format
Command	Stop
Reply	OK or ERROR, <Error Message>

Examples:

```
Command: Stop
Reply: OK
```

Trigger

The Trigger command triggers a single frame capture. This command is only valid if the sensor is configured in the Software trigger mode and the sensor is in the Running state.

Formats

Message	Format
Command	Trigger
Reply	OK or ERROR, <Error Message>

Examples:

```
Command: Trigger
Reply: OK
```

LoadJob

The Load Job command switches the active sensor configuration.

Formats

Message	Format
Command	LoadJob,job file name If the job file name is not specified, the command returns the current job name. An error message is generated if no job is loaded. ".job" is appended if the filename does not have an extension.
Reply	OK or ERROR, <Error Message>

Examples:

```
Command: LoadJob,test.job
Reply: OK,test.job loaded successfully
Command: LoadJob
Reply: OK,test.job
Command: LoadJob,wrongname.job
Reply: ERROR, failed to load wrongname.job
```

Stamp

The Stamp command retrieves the current time, encoder, and/or the last frame count.

Formats

Message	Format
Command	Stamp,time,encoder,frame If no parameters are given, time, encoder, and frame will be returned. There could be more than one selection.
Reply	If no arguments are specified: OK, time, <time value>, encoder, <encoder position>, frame, <frame count> ERROR, <Error Message> If arguments are specified, only the selected stamps will be returned.

Examples:

```
Command: Stamp
Reply: OK,Time,9226989840,Encoder,0,Frame,6
Command: Stamp,frame
Reply: OK,6
```

Clear Alignment

The Clear Alignment command clears the alignment record generated by the alignment process.

Formats

Message	Format
Command	ClearAlignment
Reply	OK or ERROR, <Error Message>

Examples:

Command: ClearAlignment

Reply: OK

Moving Alignment

The Moving Alignment command performs an alignment based on the settings in the sensor's live job file. A reply to the command is sent when the alignment has completed or failed. The command is timed out if there has been no progress after one minute.

Formats

Message	Format
Command	MovingAlignment
Reply	If no arguments are specified OK or ERROR, <Error Message>

Examples:

Command: MovingAlignment

Reply: OK

Command: MovingAlignment

Reply: ERROR, ALIGNMENT FAILED

Stationary Alignment

The Stationary Alignment command performs an alignment based on the settings in the sensor's live job file. A reply to the command is sent when the alignment has completed or failed. The command is timed out if there has been no progress after one minute.

Formats

Message	Format
Command	StationaryAlignment
Reply	If no arguments are specified OK or ERROR, <Error Message>

Examples:

Command: StationaryAlignment

Reply: OK

Command: StationaryAlignment

Reply: ERROR, ALIGNMENT FAILED

Set Runtime Variables

The Set Runtime Variables command sets the runtime variables, using the specified index, length, and data. Values are integers.

Formats

Message	Format
Command	setvars,index,length,data
	Where <i>data</i> is the delimited integer values to be set.
Reply	OK or ERROR

Examples:

Command: `setvars,0,4,1,2,3,4`

Reply: OK

Get Runtime Variables

The Get Runtime Variables command gets the runtime variables, using the specified index and length.

Formats

Message	Format
Command	setvars,index,length
Reply	OK,data
	Where <i>data</i> is the delimited data for the passed length.

Examples:

Command: `getvars,0,4`

Reply: OK,1,2,3,4

Data Channel

The following sections list the actions available on the data channel.

Optional parameters are shown in *italics*. The placeholder for data is surrounded by brackets (<>). In the examples, the delimiter is set to ','.

Result

The Result command retrieves measurement values and decisions.

Formats

Message	Format
Command	Result,measurement ID,measurement ID...
Reply	If no arguments are specified, the custom format data string is used. OK, <custom data string> ERROR, <Error Message>

Message	Format
	If arguments are specified, OK, <data string in standard format> ERROR, <Error Message>

Examples:

Standard data string for measurements ID 0 and 1:

```
Result,0,1
```

```
OK,M00,00,V151290,D0,M01,01,V18520,D0
```

Standard formatted measurement data with a non-existent measurement of ID 2:

```
Result,2
```

```
ERROR,Specified measurement ID not found. Please verify your input
```

Custom formatted data string (%time, %value[0], %decision[0]):

```
Result
```

```
OK,1420266101,151290,0
```

Value

The Value command retrieves measurement values.

Formats

Message	Format
Command	Value,measurement ID,measurement ID...
Reply	If no arguments are specified, the custom format data string is used. OK, <custom data string> ERROR, <Error Message> If arguments are specified, OK, <data string in standard format, except that the decisions are not sent> ERROR, <Error Message>

Examples:

Standard data string for measurements ID 0 and 1:

```
Value,0,1
```

```
OK,M00,00,V151290,M01,01,V18520
```

Standard formatted measurement data with a non-existent measurement of ID 2:

```
Value,2
```

```
ERROR,Specified measurement ID not found. Please verify your input
```

Custom formatted data string (%time, %value[0]):

```
Value
```

```
OK, 1420266101, 151290
```

Decision

The Decision command retrieves measurement decisions.

Formats

Message	Format
Command	Decision,measurement ID,measurement ID...
Reply	If no arguments are specified, the custom format data string is used. OK, <custom data string> ERROR, <Error Message> If arguments are specified, OK, <data string in standard format, except that the values are not sent> ERROR, <Error Message>

Examples:

Standard data string for measurements ID 0 and 1:

```
Decision,0,1
```

```
OK,M00,00,D0,M01,01,D0
```

Standard formatted measurement data with a non-existent measurement of ID 2:

```
Decision,2
```

```
ERROR,Specified measurement ID not found. Please verify your input
```

Custom formatted data string (%time, %decision[0]):

```
Decision
```

```
OK,1420266101, 0
```

Health Channel

The following sections list the actions available on the health channel.

Optional parameters are shown in *italics*. The placeholder for data is surrounded by brackets (<>). In the examples, the delimiter is set to ','.

Health

The Health command retrieves health indicators. See *Health Results* on page 396 for details on health indicators.

Formats

Message	Format
Command	Health,health indicator ID.Optional health indicator instance ... More than one health indicator can be specified. Note that the health indicator instance is optionally attached to the indicator ID with a '.'. If the health indicator instance field is used the delimiter cannot be set to '.'.
Reply	OK, <health indicator of first ID>, <health indicator of second ID> ERROR, <Error Message>

Examples:

```
health,2002,2017
```

```
OK,46,1674
```

```
Health
```

```
ERROR,Insufficient parameters.
```

Standard Result Format

A sensor can send measurement results either in the standard format or in a custom format. In the standard format, you select in the web interface which measurement values and decisions to send. For each measurement the following message is transmitted:

M	t _n	,	i _n	,	V	v _n	,	D	d ₁	CR
---	----------------	---	----------------	---	---	----------------	---	---	----------------	----

Field	Shorthand	Length	Description
MeasurementStart	M	1	Start of measurement frame.
Type	t _n	n	Hexadecimal value that identifies the type of measurement. The measurement type is the same as defined elsewhere (see <i>Data Results</i> on page 387).
Id	i _n	n	Decimal value that represents the unique identifier of the measurement.
ValueStart	V	1	Start of measurement value.
Value	v _n	n	Measurement value, in decimal. The unit of the value is measurement-specific.
DecisionStart	D	1	Start of measurement decision.
Decision	d ₁	1	Measurement decision, a bit mask where:

Field	Shorthand	Length	Description
			Bit 0: 1 - Pass 0 - Fail
			Bits 1-7: 0 - Measurement value OK 1 - Invalid value 2 - Invalid anchor

Custom Result Format

In the custom format, you enter a format string with place holders to create a custom message. The default format string is "%time, %value[0], %decision[0]".

Result Placeholders

Format Value	Name	Explanation
%time	Time	Timestamp in microseconds of the last frame.
%encoder	Encoder Position	Encoder position of the last frame when the image data was scanned/taken.
%frame	Frame Index	Frame number of the last frame.
%value[Measurement ID]	Value	Measurement value of the specified measurement ID. The ID must correspond to an existing measurement. The value output will be displayed as an integer in micrometers.
%decision [Measurement ID]	Decision	Measurement decision, where the selected measurement ID must correspond to an existing measurement. Measurement decision is a bit mask where: Bit 0: 1 - Pass 0 - Fail Bits 1-7: 0 - Measurement value OK 1 - Invalid value 2 - Invalid anchor

C language *printf*-style formatting is also supported: for example, %sprintf[%09d, %value[0]]. This allows fixed length formatting for easier input parsing in PLC and robot controller logic.

Selcom Protocol

This section describes the Selcom serial protocol settings and message formats supported by sensors.

To use the Selcom protocol, it must be enabled and configured in the active job.

For information on configuring the protocol using the Web interface, see *Serial Output* on page 244.

 Units for data scales use the standard units (mm, mm², mm³, and degrees).

Serial Communication

Data communication is synchronous using two unidirectional (output only) RS-485 serial channels: data (Serial_Out0) and clock (Serial_Out1). See *Serial Output* on page 544 for cable pinout information.

Measurement results are sent on the serial output (data) in asynchronous mode. Measurement values and decisions can be transmitted to an RS-485 receiver, but job handling and control operations must be performed through the sensor's web interface or through communications on the Ethernet output.

Connection Settings

The Selcom protocol uses the following connection settings:

Serial Connection Settings

Parameter	Value
Data Bits	16
Baud Rate (b/s)	96000, 512000, 1024000
Format	Binary

Message Format

The data channel is valid on the rising edge of the clock and data is output with the most significant bit first, followed by control bits for a total of 16 bits of information per frame. The time between the start of the camera exposure and the delivery of the corresponding range data is fixed to a deterministic value.

The sensor can output data using one of four formats, illustrated below, where:

- MSB = most significant bit
- LSB = least significant bit
- C = data valid bit (high = invalid)
- S = whether data is acquired in search mode or track mode (high = search mode)

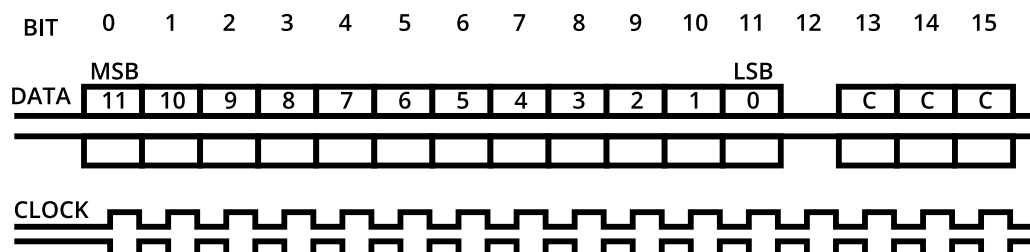

12-bit data format (SLS mode; "SLS" in the web interface)

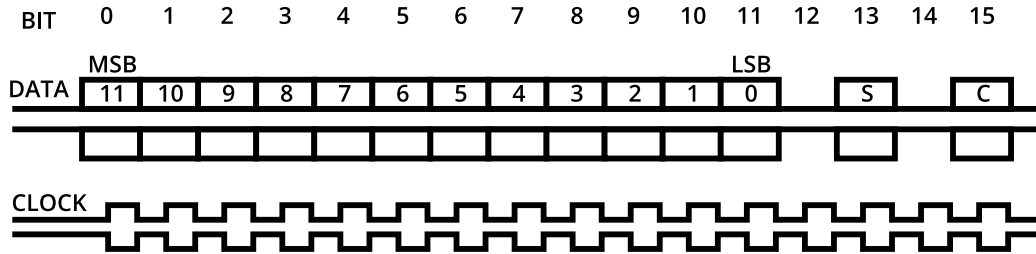

12-bit data format with Search/Track bit

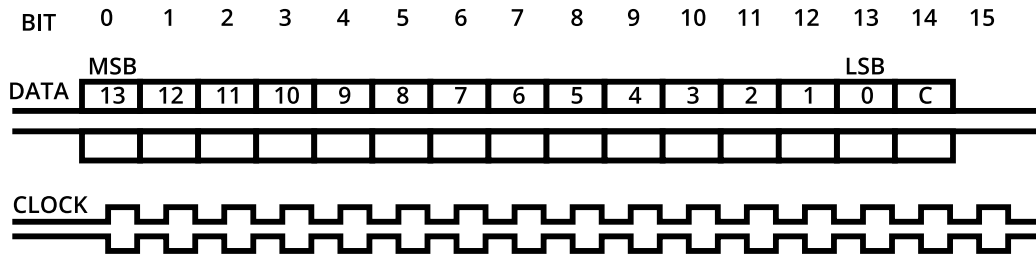

14-bit data format

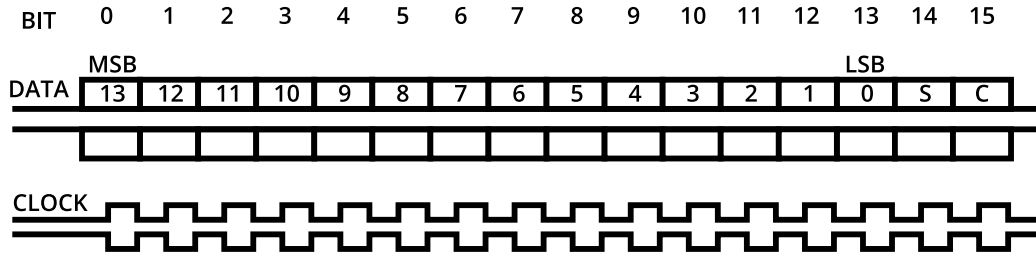

14-bit data format with Search/Track bit

Development Kits

These sections describe the following development kits:

- [Software Development Kit \(GoSDK\)](#)
- [Gocator Development Kit \(GDK\)](#)

GoSDK

The Gocator Software Development Kit (GoSDK) includes open-source software libraries and documentation that can be used to programmatically access and control Gocator sensors. To get the latest version of the *Gocator SDK* package, go to <http://lmi3d.com/support>, choose your product from the Product Downloads section, and download it from the Download Center.

For information on the ports the SDK uses (for example, in order to ensure ports are not blocked over your network), see *Required Ports* on page 48.



If you switch jobs or make changes to a job using the SDK or a protocol (from a PLC), the switch or changes are not automatically displayed in the web interface: you must refresh the browser to see these.

You can download the Gocator SDK from within the Web interface.

Software Development Kit (SDK):

Download

To download the SDK:

1. Go to the **Manage** page and click on the **Support** category
2. Next to **Software Development Kit (SDK)**, click **Download**
3. Choose the location for the SDK on the client computer.

Applications compiled with previous versions of the SDK are compatible with sensor firmware if the major version numbers of the protocols match. For example, an application compiled with version 5.0 of the SDK (which uses protocol version 5.0) will be compatible with a sensor running firmware version 5.1 (which uses protocol version 5.1). However, any new features in firmware version 5.1 would not be available.

Applications compiled using SDK version 4.x are compatible with sensors running firmware 5.x.

Applications compiled using SDK version 3.x are not compatible with sensors running firmware 4.x. In this case, you must rewrite the application with the SDK version corresponding to the sensor firmware in use.

For more information about programming with the SDK, refer to the class reference and sample programs included in the SDK.

Setup and Locations

Class Reference

The full GoSDK class reference is found by accessing the following file:

14400-x.x.x.xx_SOFTWARE_GO_SDK\GO_SDK\doc\GoSdk\Gocator_1x00\GoSdk.html

Examples

Examples showing how to perform various operations are provided, each one targeting a specific area. For Visual Studio, the examples can be found in solution files specific to different versions of Visual Studio. For example, *GoSdk-2017.sln* is for use with Visual Studio 2017. A make file for Linux systems is also provided.



To compile the examples in Visual Studio, you may need to retarget the solution to the installed Windows SDK version. You can do this through the **Retarget solution** option in the solution context menu.

To run the GoSDK examples, make sure the required DLLs are copied beside the executable. In most cases only *GoSDK.dll* and *kApi.dll* are required, but with .NET and the accelerator additional DLLs are needed. Please refer to the SDK samples to see which DLLs are required.

Example Project Environment Variable

All GoSDK example projects use the environment variable *GO_SDK_4*. The environment variable should point to the *GO_SDK* directory, for example, *C:\14400-4.0.9.156_SOFTWARE_GO_SDK\GO_SDK*.

Header Files

Header files are referenced with *GoSdk* as the source directory, for example: `#include <GoSdk/GoSdk.h>`. The SDK header files also reference files from the *kApi* directory.

Functional Hierarchy of Classes

This section describes the functional hierarchy of the classes in the Gocator SDK ("GoSDK"). In the following diagram, classes higher in the hierarchy often provide resources for classes lower in the hierarchy, and for this reason should be instantiated earlier in a client application.

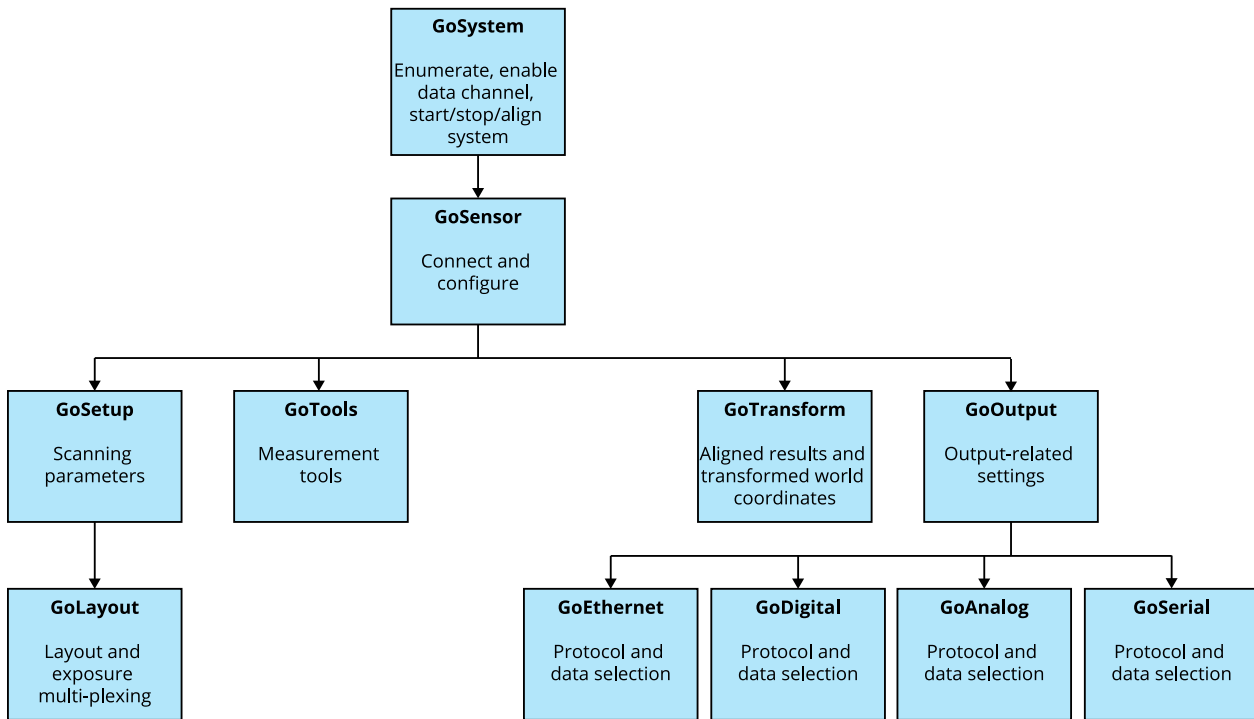

GoSystem

The *GoSystem* class is the top-level class in the SDK. Multiple sensors can be enabled and connected in one *GoSystem*. Only one *GoSystem* object is required for multi-sensor control.

Refer to the *How To Use The Open Source SDK To Fully Control A Gocator Multi-sensor System* how-to guide in http://lmi3d.com/sites/default/files/APPNOTE_Gocator_4.x_Multi_Sensor_Guide.zip for details on how to control and operate a multi-sensor system using the SDK.



All objects that are explicitly created by the user or passed via callbacks should be destroyed by using the *GoDestroy* function.

GoSensor

GoSensor represents a physical sensor. If the physical sensor is the Main sensor in a dual-sensor setup, it can be used to configure settings that are common to both sensors.

GoSetup

The *GoSetup* class represents a device's configuration. The class provides functions to get or set all of the settings available in the web interface.

GoSetup is included inside *GoSensor*. It encapsulates scanning parameters, such as exposure, resolution, spacing interval, etc. For parameters that are independently controlled for Main and Buddy sensors, functions accept a role parameter.

GoLayout

The *GoLayout* class represents layout-related sensor configuration.

GoTools

The *GoTools* class is the base class of the measurement tools. The class provides functions for getting and setting names, retrieving measurement counts, etc.

GoTransform

The *GoTransform* class represents a sensor transformation and provides functions to get and set transformation information, as well as encoder-related information.

GoOutput

The *GoOutput* class represents output configuration and provides functions to get the specific types of output (Analog, Digital, Ethernet, and Serial). Classes corresponding to the specific types of output (*GoAnalog*, *GoDigital*, *GoEthernet*, and *GoSerial*) are available to configure these outputs.

Data Types

The following sections describe the types used by the SDK and the *kApi* library.

Value Types

GoSDK is built on a set of basic data structures, utilities, and functions, which are contained in the *kApi* library.

The following basic value types are used by the *kApi* library.

Value Data Types

Type	Description
k8u	8-bit unsigned integer
k16u	16-bit unsigned integer
k16s	16-bit signed integer
k32u	32-bit unsigned integer
k32s	32-bit signed integer
k64s	64-bit signed integer
k64u	64-bit unsigned integer
k64f	64-bit floating number
kBool	Boolean, value can be kTRUE or kFALSE
kStatus	Status, value can be kOK or kERROR
kIpAddress	IP address

Output Types

The following output types are available in the SDK.

Output Data Types

Data Type	Description
GoAlignMsg	Represents a message containing an alignment result.

Data Type	Description
GoBoundingBoxMatchMsg	Represents a message containing bounding box based part matching results.
GoDataMsg	Represents a base message sourced from the data channel. See <i>GoDataSet Type</i> below for more information.
GoEdgeMatchMsg	Represents a message containing edge based part matching results.
GoEllipseMatchMsg	Represents a message containing ellipse based part matching results.
GoExposureCalMsg	Represents a message containing exposure calibration results.
GoMeasurementMsg	Represents a message containing a set of GoMeasurementData objects.
GoProfileIntensityMsg	Represents a data message containing a set of profile intensity arrays.
GoProfileMsg	Represents a data message containing a set of profile arrays.
GoRangeIntensityMsg	Represents a data message containing a set of range intensity data.
GoRangeMsg	Represents a data message containing a set of range data.
GoResampledProfileMsg	Represents a data message containing a set of resampled profile arrays.
GoSectionMsg	Represents a data message containing a set of section arrays.
GoSectionIntensityMsg	Represents a data message containing a set of profile intensity arrays.
GoStampMsg	Represents a message containing a set of acquisition stamps.
GoSurfaceIntensityMsg	Represents a data message containing a surface intensity array.
GoSurfaceMsg	Represents a data message containing a surface array.
GoVideoMsg	Represents a data message containing a video image.

Refer to the *GoSdkSamples* sample code for examples of acquiring data using these data types.



See *Setup and Locations* on page 481 for more information on the code samples.

GoDataSet Type

Data are passed to the data handler in a *GoDataSet* object. The *GoDataSet* object is a container that can contain any type of data, including scan data (ranges or profiles), measurements, and results from various operations. Data inside the *GoDataSet* object are represented as messages.

The following illustrates the content of a *GoDataSet* object of a range mode setup with two measurements.

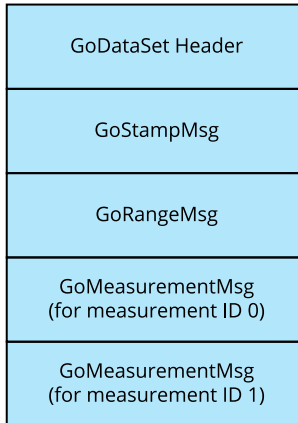

After receiving the *GoDataSet* object, you should call *GoDestroy* to dispose the *GoDataSet* object. You do not need to dispose objects within the *GoDataSet* object individually.

 All objects that are explicitly created by the user or passed via callbacks should be destroyed by using the *GoDestroy* function.

Measurement Values and Decisions

Measurement values and decisions are 32-bit signed values (k32s). See *Value Types* on page 483 for more information on value types.

The following table lists the decisions that can be returned.

Measurement Decisions

Decision	Description
1	The measurement value is between the maximum and minimum decision values. This is a pass decision.
0	The measurement value is outside the maximum and minimum. This is a fail decision.
-1	The measurement is invalid (for example, the target is not within range). Provides the reason for the failure.
-2	The tool containing the measurement is anchored and has received invalid measurement data from one of its anchors. Provides the reason for the failure.

Refer to the *SetupMeasurement* example for details on how to add and configure tools and measurements. Refer to the *ReceiveMeasurement* example for details on how to receive measurement decisions and values.

 You should check a decision against ≤ 0 for failure or invalid measurement.

Batching

One *GoDataSet* object can contain data from multiple frames. Each message has a *Count* property that specifies how many frames of data are included. The following illustrates the data structure when three frames of data are contained inside a *GoDataSet* object.

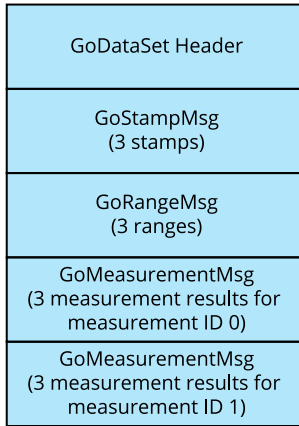

The batching size is dynamically adjusted to ensure the sensor’s CPU keeps up with the messages delivered with the shortest latency.

Operation Workflow

Applications created using the SDK typically use the following programming sequence

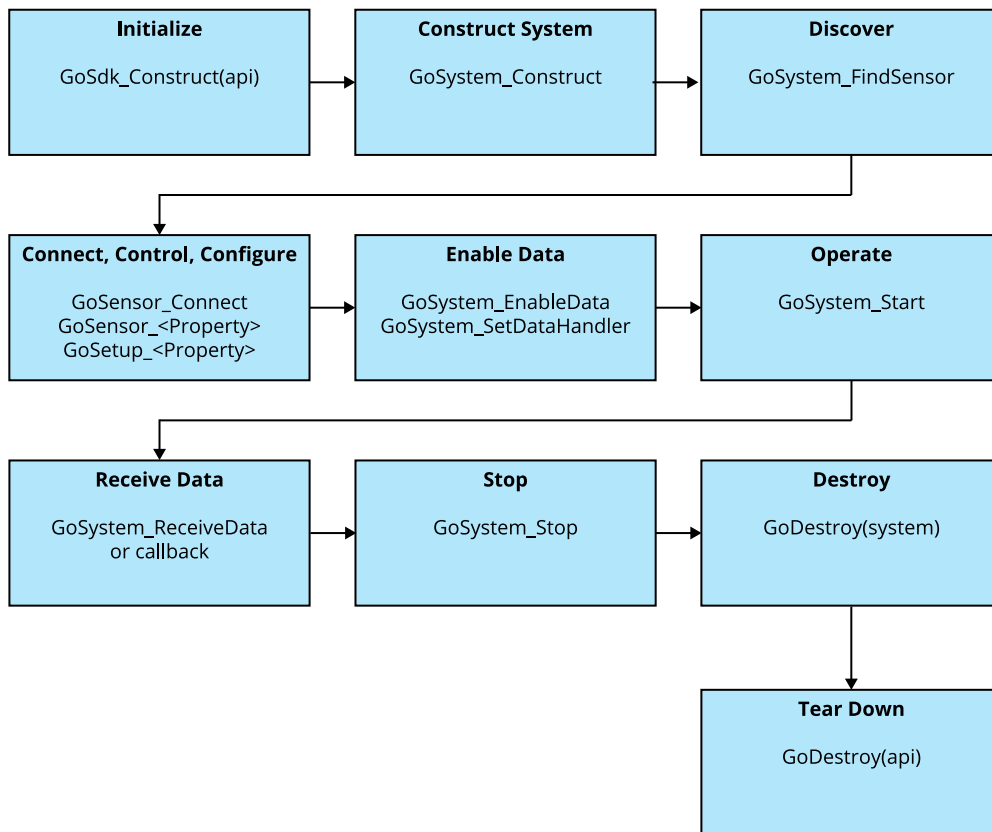

See *Setup and Locations* on page 481 for more information on the code samples referenced below.



Sensors must be connected before the system can enable the data channel.



All GoSDK data functions are named *Go<Object>_<Function>*, for example, *GoSensor_Connect*. For property access functions, the convention is *Go<Object>_<Property Name>* for reading the property and *Go<Object>_Set<Property Name>* for writing it, for example, *GoMeasurement_DecisionMax* and *GoMeasurement_SetDecisionMax*, respectively.

Initialize GoSdk API Object

Before the SDK can be used, the *GoSdk* API object must be initialized by calling *GoSdk_Construct(api)*:

```
kAssembly api = kNULL;
if ((status = GoSdk_Construct(&api)) != kOK)
{
    printf("Error: GoSdk_Construct:%d\n", status);
    return;
}
```

When the program finishes, call *GoDestroy(api)* to destroy the API object.

Discover Sensors

Sensors are discovered when *GoSystem* is created, using *GoSystem_Construct*. You can use *GoSystem_SensorCount* and *GoSystem_SensorAt* to iterate all the sensors that are on the network.

GoSystem_SensorCount returns the number of sensors physically in the network.

Alternatively, use *GoSystem_FindSensorById* or *GoSystem_FindSensorByIpAddress* to get the sensor by ID or by IP address.

Refer to the *Discover* example for details on iterating through all sensors. Refer to other examples for details on how to get a sensor handle directly from IP address.

Connect Sensors

Sensors are connected by calling *GoSensor_Connect*. You must first get the sensor object by using *GoSystem_SensorAt*, *GoSystem_FindSensorById*, or *GoSystem_FindSensorByIpAddress*.

Configure Sensors

Some configuration is performed using the *GoSensor* object, such as managing jobs, uploading and downloading files, scheduling outputs, setting alignment reference, etc. Most configuration is however performed through the *GoSetup* object, for example, setting scan mode, exposure, exposure mode, active area, speed, alignment, filtering, subsampling, etc. Surface generation is configured through the *GoSurfaceGeneration* object and part detection settings are configured through the *GoPartDetection* object.

See *Functional Hierarchy of Classes* on page 481 for information on the different objects used for configuring a sensor. Sensors must be connected before they can be configured.

Refer to the *Configure* example for details on how to change settings and to switch, save, or load jobs. Refer to the *BackupRestore* example for details on how to back up and restore settings.

Enable Data Channels

Use `GoSystem_EnableData` to enable the data channels of all connected sensors.

Perform Operations

Operations are started by calling `GoSystem_Start`, `GoSystem_StartAlignment`, and `GoSystem_StartExposureAutoSet`.

Refer to the *StationaryAlignment* and *MovingAlignment* examples for details on how to perform alignment operations. Refer to the *ReceiveRange*, *ReceiveProfile*, and *ReceiveWholePart* examples for details on how to acquire data.

Example: Configuring and starting a sensor with the API

```
#include <GoSdk/GoSdk.h>

void main()
{
    kIpAddress ipAddress;
    GoSystem system = kNULL;
    GoSensor sensor = kNULL;
    GoSetup setup = kNULL;

    //Construct the GoSdk library.
    GoSdk_Construct(&api);

    //Construct a sensor system object.
    GoSystem_Construct(&system, kNULL);

    //Parse IP address into address data structure
    kIpAddress_Parse(&ipAddress, SENSOR_IP);

    //Obtain GoSensor object by sensor IP address
    GoSystem_FindSensorByIpAddress(system, &ipAddress, &sensor)

    //Connect sensor object and enable control channel
    GoSensor_Connect(sensor);

    //Enable data channel
    GoSensor_EnableData(system, kTRUE)

    //[Optional] Setup callback function to receive data asynchronously
    //GoSystem_SetDataHandler(system, onData, &contextPointer)
    //Retrieve setup handle
    setup = GoSensor_Setup(sensor);

    //Reconfigure system to use time-based triggering.
```

```

GoSetup_SetTriggerSource (setup, GO_TRIGGER_TIME);

//Send the system a "Start" command.
GoSystem_Start (system);

//Data will now be streaming into the application
//Data can be received and processed asynchronously if a callback function has been
//set (recommended)
//Data can also be received and processed synchronously with the blocking call
//GoSystem_ReceiveData (system, &dataset, RECEIVE_TIMEOUT)
//Send the system a "Stop" command.
GoSystem_Stop (system);

//Free the system object.
GoDestroy (system);

//Free the GoSdk library
GoDestroy (api);
}

```

Limiting Flash Memory Write Operations

Several operations and Gocator SDK functions write to the sensor's flash memory. The lifetime of the flash memory is limited by the number of write cycles. Therefore it is important to avoid frequent write operation to the sensor's flash memory when you design your system with the SDK.

 Power loss during flash memory write operation will also cause sensors to enter rescue mode.

 This topic applies to all Gocator sensors.

SDK Write-Operation Functions

Name	Description
GoSensor_Restore	Restores a backup of sensor files.
GoSensor_RestoreDefaults	Restores factory default settings.
GoSensor_CopyFile	Copies a file within the connected sensor. The flash write operation does not occur if GoSensor_CopyFile function is used to load an existing job file. This is accomplished by specifying "_live" as the destination file name.
GoSensor_DeleteFile	Deletes a file in the connected sensor.
GoSensor_SetDefaultJob	Sets a default job file to be loaded on boot.
GoSensor_UploadFile	Uploads a file to the connected sensor.
GoSensor_Upgrade	Upgrades sensor firmware.
GoSystem_StartAlignment	When alignment is performed with alignment reference set to fixed, flash memory is written immediately after alignment. GoSensor_

Name	Description
	SetAlignmentReference() is used to configure alignment reference.
GoSensor_SetAddress	Configures a sensor's network address settings.
GoSensor_ChangePassword	Changes the password associated with the specified user account.

System created using the SDK should be designed in a way that parameters are set up to be appropriate for various application scenarios. Parameter changes not listed above will not invoke flash memory write operations when the changes are not saved to a file using the GoSensor_CopyFile function. Fixed alignment should be used as a means to attach previously conducted alignment results to a job file, eliminating the need to perform a new alignment.

GDK

The Gocator Development Kit (GDK) is a framework for developing and testing custom Gocator tools containing your own algorithms, and then deploying them to Gocator sensors.

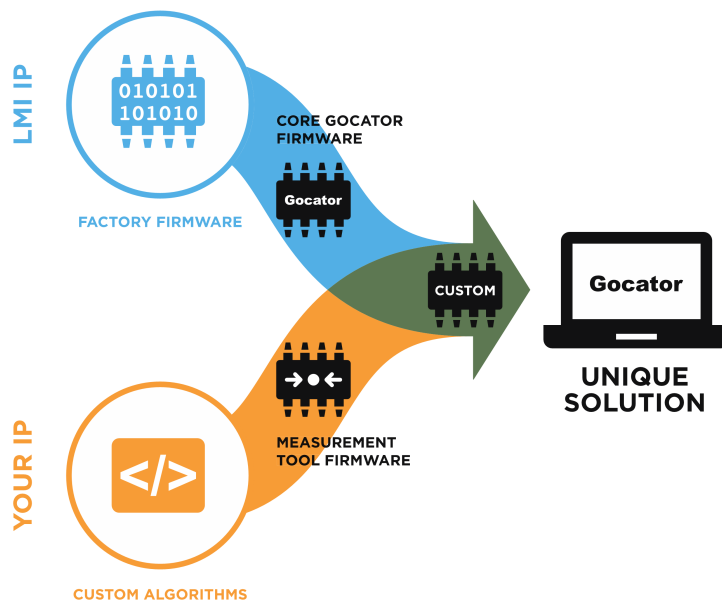

Custom tools created with the GDK act much like native Gocator data output tools (providing measurements, geometric features, data and generic outputs) with support for multiple input parameters), running at native speeds and taking advantage of features such as anchoring. The GDK supports all data types, and tools created with the GDK use the same data visualization as native tools.

Benefits

When you use the GDK to create custom measurement tools, you have complete control over how and where your custom measurement tools can be used, which protects your intellectual property.

You can also easily troubleshoot and modify your tools on-site, letting you respond quickly to your customers' urgent issues.

Supported Sensors

The GDK is available for free for the following Gocator sensors:

- Gocator 1300 series
- Gocator 2100 series
- Gocator 2300 series
- Gocator 2400 series
- Gocator 2500 series
- Gocator 2880
- Gocator 3210 and Gocator 3500 series

Typical Workflow

The following is the typical workflow for creating and deploying custom measurement tools:









- Develop and build tools using the GDK project files and libraries in Microsoft Visual Studio, targeting Win32.
- Debug the tools using the emulator on a PC.
- Build the tools into a custom firmware binary.
- Upload the custom firmware to a sensor.

Installation and Class Reference

The GDK project and library files are in the *GDK* package (14524-x.x.x.xx_SOFTWARE_GDK.zip). To download the package, go to <http://lmi3d.com/support>, choose your product from the Product Downloads section, and download it from the Download Center.

After downloading the package, extract the package to a directory.

You can access full installation and setup instructions, as well as the complete class reference documentation, by double-clicking the *Guide* shortcut under the root directory.

 bin	8/4/2016 2:08 AM	File folder
 doc	8/4/2016 2:10 AM	File folder
 Gocator	8/4/2016 2:14 AM	File folder
 lib	8/4/2016 2:15 AM	File folder
 pkg	8/4/2016 2:16 AM	File folder
 Platform	8/4/2016 2:16 AM	File folder
 res	8/4/2016 2:16 AM	File folder
 Guide	8/3/2016 1:39 PM	Shortcut

Required Tools

The GDK requires Microsoft Visual Studio 2017, as well as various other tools provided in the *GDK Prerequisites* package (14525_x.x.x.x_SOFTWARE_GDK_Prerequisites.zip). This package is available in LMI's Downloads Center (see above for download location).

Getting Started with the Example Code

The best way to get started is with the GDK sample code. You can find the sample projects under `Gocator\GDKSampleApp`. This project is ready for you to build and use as a template for new projects.

Start by opening `GDK.sln` in Visual Studio 2017.

Building the Sample Code

You can build the sample code for working with either the emulator or a sensor. To do this, choose the target and then build the solution.

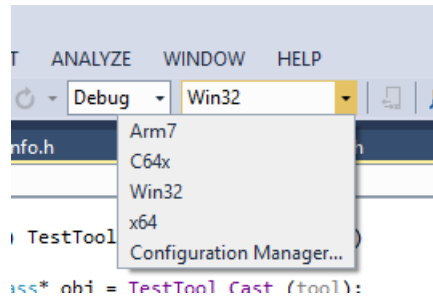

The following targets are available:

- Win32/x64 for debugging code and emulating a sensor to test tools (on a PC)
- Arm7 for building for Gocator 2300C and 2400 series sensors
- C64x for Gocator 1300, 2300A, 2300B, 3210, and 3506 series sensors

The Win32 target supports Debug and Release builds. The Arm7 and C64x targets (sensors) only support Release builds.

Tool Registration

For a tool to be available to a user in the sensor web interface, you must add it to the project assembly in `Asm.c`.

```
#include <GdkSampleApp/Asm.h>
#include <GdkSampleApp/TestProfileSelect.h>
#include <GdkSampleApp/TestSurfaceSelect.h>
#include <GdkSampleApp/TestSurfaceConfiguration.h>
#include <GdkSampleApp/TestSurfaceGraphics.h>
#include <Gdk/GdkLib.h>
#include <GoSensor/Version.h>
#include <GoSensorAppLib/GsaDef.h>
#include <GoSensorAppLib/GsaAsm.h>

kBeginAssembly (Tool, ToolAsm, TOOL_VERSION, GOCATOR_VERSION)
    kAddDependency (GdkLib)
    kAddType (TestProfileSelect)
    kAddType (TestSurfaceSelect)
    kAddType (TestSurfaceConfiguration)
    kAddType (TestSurfaceGraphics)
kEndAssembly ()
```

You can add multiple tools in a GDK project. As seen above, `TestProfileSelect`, `TestSurfaceSelect`, `TestSurfaceConfiguration`, etc. will be available for users from the dropdown menu in the **Tools** panel in sensor's web interface.

Tool Definitions

You must add standard entry functions (methods) for each tool. The class table declares the entry functions:

```
kBeginClass (Tool, TestTool, GdkTool)
    kAddVMethod (TestTool, kObject, VRelease)
    kAddVMethod (TestTool, GdkTool, VInit)
    kAddVMethod (TestTool, GdkTool, VName)
    kAddVMethod (TestTool, GdkTool, VDescribe)
    kAddVMethod (TestTool, GdkTool, VNewToolConfigInstanced)
    kAddVMethod (TestTool, GdkTool, VNewMeasurementConfigInstanced)
    kAddVMethod (TestTool, GdkTool, VUpdateConfigInstanced)
    kAddVMethod (TestTool, GdkTool, VNewFeatureConfigInstanced)
    kAddVMethod (TestTool, GdkTool, VNewToolDataOutputConfigInstanced)
    kAddVMethod (TestTool, GdkTool, VIsVisible)
    kAddVMethod (TestTool, GdkTool, VCalcDataOutputRegionInstanced)
    kAddVMethod (TestTool, GdkTool, VStart)
    kAddVMethod (TestTool, GdkTool, VStop)
    kAddVMethod (TestTool, GdkTool, VProcess)
kEndClass ()

ToolFx (kStatus) TestTool_VDescribe (GdkToolInfo toolInfo)
{
    GdkMeasurementInfo mmt;
    GdkParamsInfo params;
    GdkParamInfo paramInfo;

    kCheck (GdkToolInfo_SetTypeName (toolInfo, TEST_PROFILE_SELECT_TOOL_NAME));
    kCheck (GdkToolInfo_SetLabel (toolInfo, TEST_PROFILE_SELECT_TOOL_LABEL));

    kCheck (GdkToolInfo_SetSourceType (toolInfo, GDK_DATA_TYPE_UNIFORM_PROFILE));

    ...
}
```

The function `<Tool Name>_VDescribe` describes the tool and its basic configuration. This function is called during sensor start-up. For more information on entry functions, see *Entry Functions* below.

 Make sure the `VDescribe` function for each tool is properly formed. Significant issues with this function (for example, overwriting memory) could prevent the sensor from starting.

 You should use the emulator to debug tools *before* deploying tools to sensors.

Entry Functions

The following table describes the main entry functions.

Function	Description
VDescribe	Defines the tool's name, data types, acceptable source options, configuration parameters, and at least one measurement.
VStart	Called when the sensor starts running (that is, the user clicks the Run button). The function gets parameters from <code>GtTool</code> . You typically allocate memory in this function.
VProcess	Called every time data is received while the sensor is running.

Function	Description
VStop	Called when the user clicks the Stop button.

The `TestSurfaceConfiguration` example shows how to create and modify parameters based on other user settings.

For full descriptions of these functions, see the GDK class reference documentation (see *Installation and Class Reference* on page 492 for information on installing the documentation).

Parameter Configurations

Each tool has two levels of parameters: tool parameters and measurement parameters.

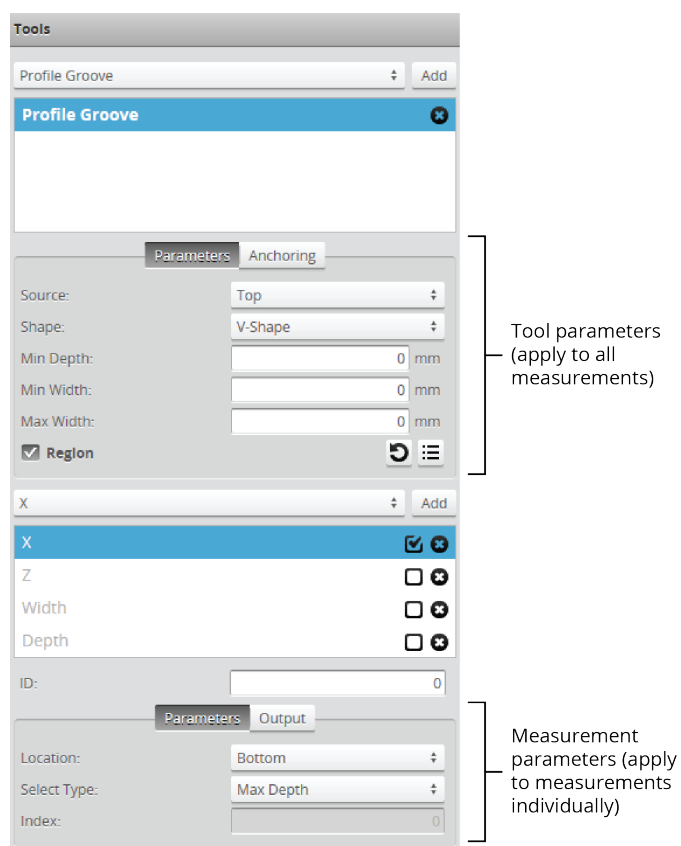

A tool can contain multiple measurements. In the image above, the Groove tool contains four measurements: X, Z, Width, and Depth. Each tool has one set of tool parameters and each measurement in a tool has one set of measurement parameters.

The following table lists the functions that provide advanced or interactive control for setting up tool and measurement parameters:

Function	Description
VNewToolConfig	Advanced method for setting default values of tool parameters based on the current sensor configuration (for example, active area). Called when a new tool is added in the interface.

Function	Description
VNewMeasurementConfig	Advanced method for setting default values of measurement parameters based on the current sensor configurations (for example, active area). Called when measurements in a tool is are added in the interface.
VUpdateConfig	Advanced method for updating the configuration based on parameters set by users.

For full descriptions of these functions, see the GDK class reference documentation (see *Installation and Class Reference* on page 492 for information on installing the documentation).

Graphics Visualization

The `GdkGraphic` function supports points and lines.

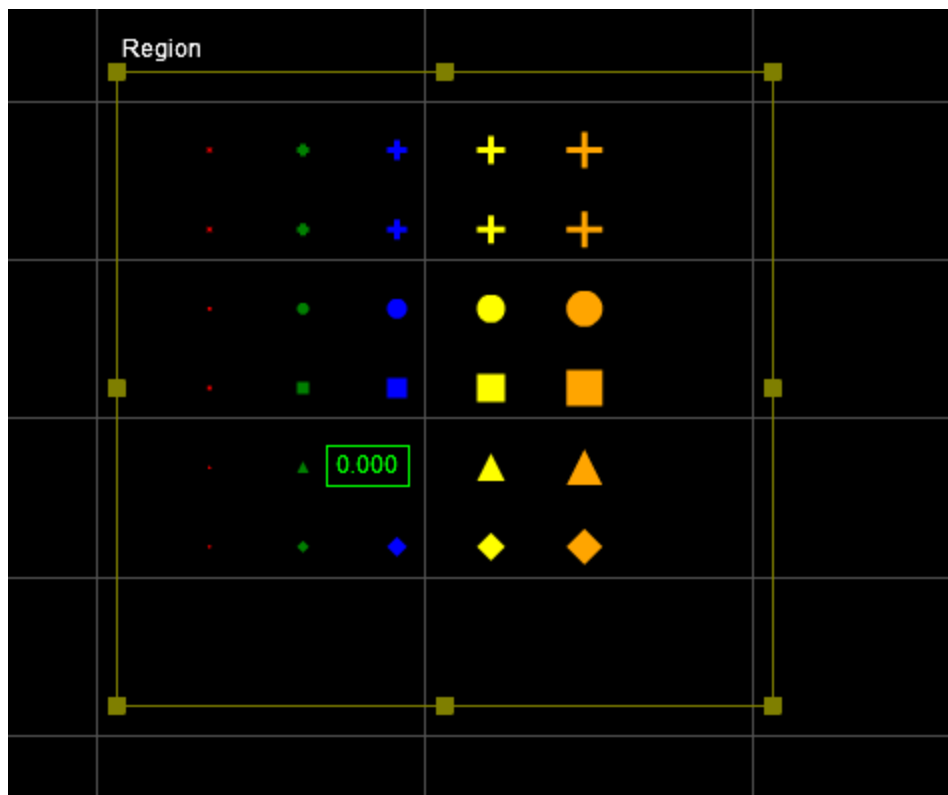

Point graphics

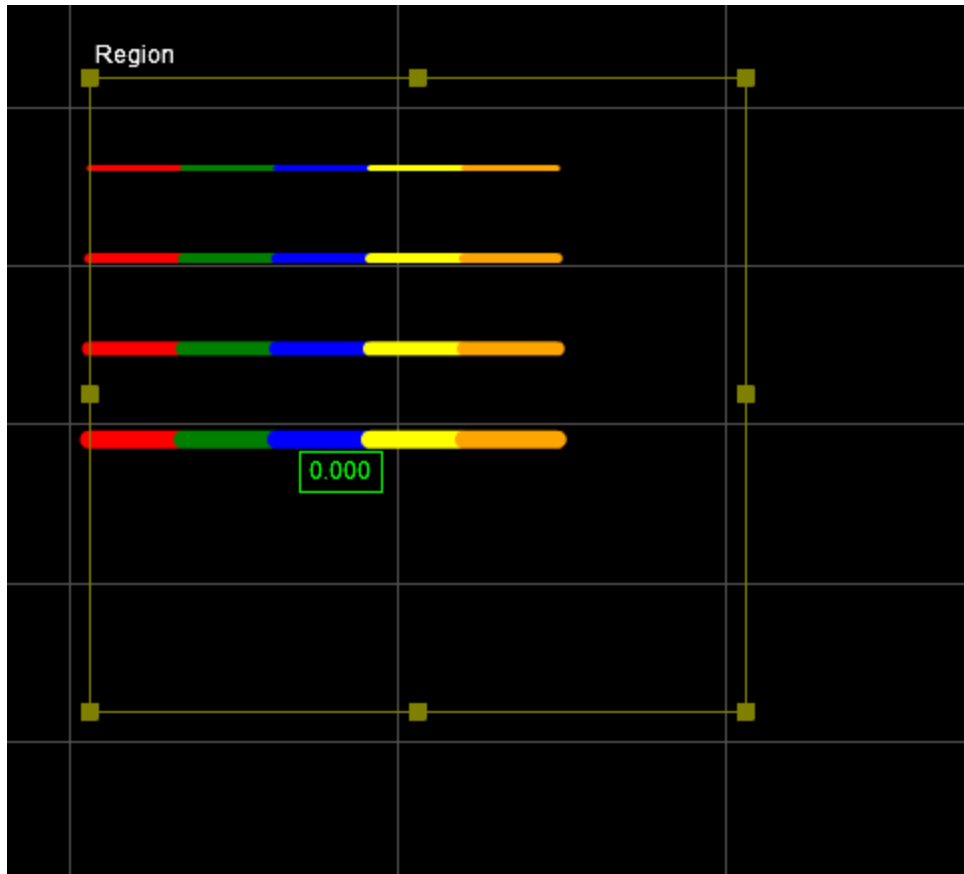

Line graphics

To create graphics:

1. Use `GdkGraphic_Construct` to create a graphic object.
2. Use `GdkGraphicPointSet_Construct` to create points or `GdkGraphicLineSet_Construct` to create lines.
3. Add the points and lines to the graphic object using `GdkGraphic_AddPointSet` and `GdkGraphic_AddLineSet`.
4. Output using `GdkToolOutput_SetRendering`.

The following illustrates the process:

```
kTest (GdkGraphic_Construct (&graphic, kObject_Alloc (tool)));
kTest (GdkGraphicPointSet_Construct (&pointSet, 4.0, kMARKER_SHAPE_CROSS, kCOLOR_LIME,
&point32f, 1, kObject_Alloc (tool)));
kTest (GdkGraphic_AddPointSet (graphic, pointSet));
kTest (GdkToolOutput_SetRendering (output, measurementIndex, graphic));
```

The GDK example `TestSurfaceGraphics` shows how to use the graphics functions.



Graphic functions take an array of `kPoint3d32f`. It does NOT accept `kPoint3d64f`.

Debugging Your Tools

We highly recommend using the emulator to debug tools you create with the GDK. By using a sensor support file and previously recorded scan data, downloaded from a physical sensor, you can completely simulate standalone and multi-sensor configurations on a PC to test your tools.

To debug your tools in the emulator:

1. Compile your code using the Win32 target (Debug or Release).
2. In the output directory, rename the DLL with the same name as your project to `GdkApp.dll`.
For example, if your project is called `MyGDKTools`, the resulting DLL should be called `MyGDKTools.dll`. You rename this DLL to `GdkApp.dll`.
The output directories are as follows:
Release: `win32`
Debug: `win32d`
3. Launch the emulator from same output directory as in step 2.
4. In the emulator, choose a scenario and start it.
5. In Visual Studio, attach the debugger to the `kFramework.exe` process.

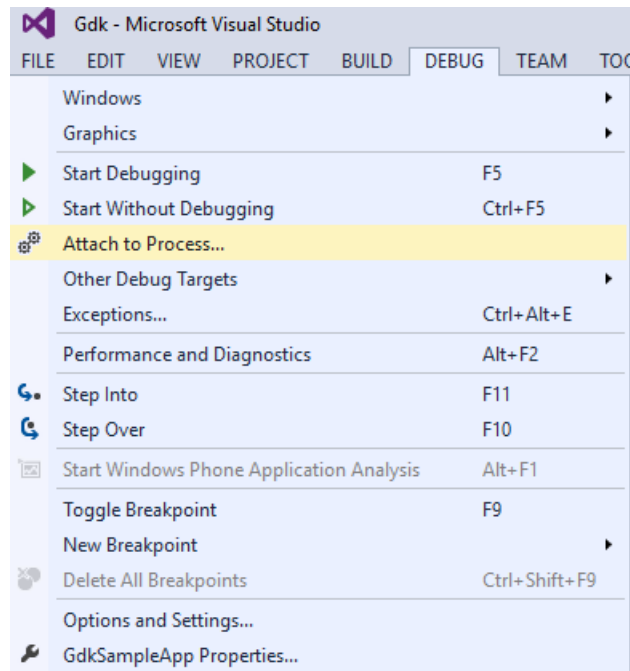

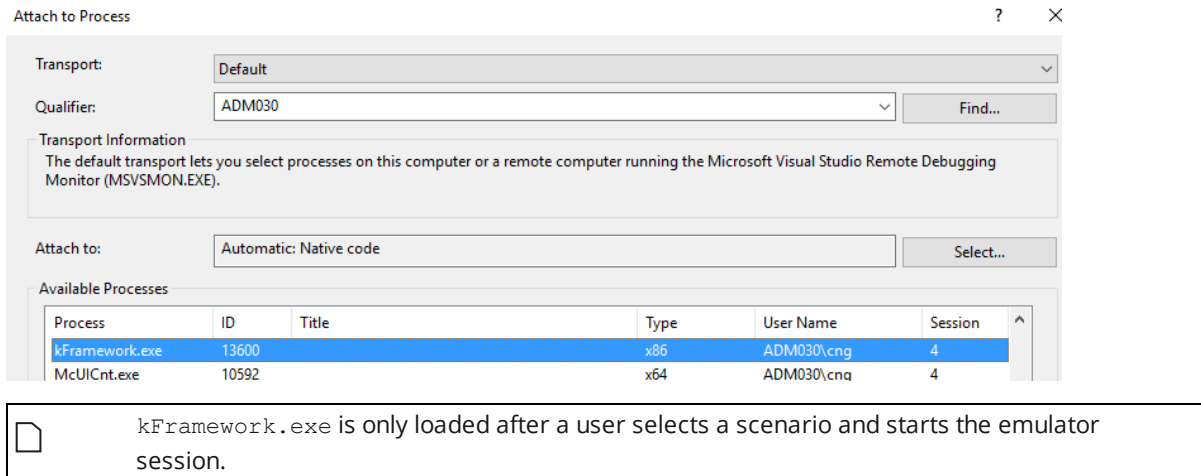

Attach to Process

Transport: Default

Qualifier: ADM030 Find...

Transport Information
The default transport lets you select processes on this computer or a remote computer running the Microsoft Visual Studio Remote Debugging Monitor (MSVSMON.EXE).

Attach to: Automatic: Native code Select...

Process	ID	Title	Type	User Name	Session
kFramework.exe	13600		x86	ADM030\cng	4
McUICnt.exe	10592		x64	ADM030\cng	4

kFramework.exe is only loaded after a user selects a scenario and starts the emulator session.

Debugging Entry Functions

VStart, *VProcess*, and *VStop* are called whenever a data record is played back in the emulator (that is, when a user clicks on the Next button or types the frame number in the frame field) with at least one tool instance. For more information on playback controls, see *Recording, Playback, and Measurement Simulation* in the Gocator user manual.

VDescribe however is called when the DLL loads, before the debugger can attach to the `kFramework.exe` process. To debug *VDescribe*, we recommend testing the function calls by putting them in *VInit*.

For information on building targets for testing in the emulator, see the GDK class reference documentation.

Tips

The following sections provide useful information for creating custom measurement tools.

Backward Compatibility with Older Versions of Tools

When loading a recording or job file that contains a custom measurement tool, the parameters in the loaded recording or job file must match those in the firmware.

By default, if declared parameters are missing from the configuration, a job file or a recording will fail to load.

There are two ways to provide backward compatibility with older parameter sets.

Define new parameters as optional

Mark a parameter as optional with the function `GdkParamInfo_SetIsOptional`. When a parameter is marked as optional, parameter parsing functions succeed even if the parameter is missing from the configuration. The missing parameter is initialized with default value.

Configuration Versioning

Over the lifetime of a tool, you may need to make changes to its interface (for example, changing or removing parameters). The user-defined aspects of a tool interface—its parameters and

measurements—are captured by `GDKToolVersionInfo` objects.

By default, a tool has just one version (`GdkToolInfo_FirstVersion`), but more versions may be added using `GdkToolInfo_AddVersion`. Whenever the interface of a tool has changed, a new version can be registered so that the new interface can be correctly parsed by the framework.

When the configuration of a tool instance is saved, the version used at the time is also saved. This saved version is used by the framework to parse the configuration. If a version is not defined by the firmware implementation, then that tool instance will not be active.

During run-time, you can query the version of the configuration of a tool instance by using `GdkToolCfg_Version`. You can then interpret the parameters depending on the version the configuration is saved in.

```
GdkFx(kStatus) GdkExampleTool_VDescribe(GdkToolInfo info)
{
    kCheck(GdkToolInfo_SetLabel(info, "Example"));

    kCheck(GdkToolInfo_SetSourceType(info, GDK_DATA_TYPE_UNIFORM_PROFILE));
    kCheck(GdkToolInfo_AddSourceOption(info, GDK_DATA_SOURCE_TOP));

    kCheck(GdkExampleTool_DescribeV0(info));
    kCheck(GdkExampleTool_DescribeV1(info));

    kCheck(GdkToolInfo_SetDefaultVersion(info, GdkToolInfo_VersionAt(info, 1)));

    return kOK;
}

GdkFx(kStatus) GdkExampleTool_DescribeV0(GdkToolInfo info)
{
    kCheck(GdkParamsInfo_Add(GdkToolInfo_Params(info), "RefRegion", GDK_PARAM_TYPE_PROFILE_
REGION, "Ref Region", kNULL));
    kCheck(GdkParamsInfo_Add(GdkToolInfo_Params(info), "Region", GDK_PARAM_TYPE_PROFILE_
REGION, "Region", kNULL));
    kCheck(GdkToolInfo_SetFirstVersionName(info, ""));

    return kOK;
}

GdkFx(kStatus) GdkExampleTool_DescribeV1(GdkToolInfo info)
{
    GdkToolVersionInfo versionInfo;

    // Auto-version

    kCheck(GdkToolInfo_AddVersion(info, kNULL, &versionInfo));
    kCheck(GdkToolVersionInfo_UseBase(versionInfo, GdkToolInfo_FirstVersion(info)));
    kCheck(GdkParamsInfo_AddFloat(GdkToolVersionInfo_Params(versionInfo), "BaseScale",
kNULL, 2.0, kNULL));

    return kOK;
}
```

Adding a new measurement does not require special handling. The new measurement is just not instantiated in a previous configuration.

Version

You can define the version number of your tools in `Asm.x.h`.

```
#define TOOL_VERSION    kVersion_Stringify_(1, 0, 0, 23)
```

The version is displayed on the **Manage** page, in the **Support** category.

The screenshot shows the 'Manage' page interface. On the left is a sidebar with a list of categories: Sensor System, Networking, Motion and Alignment, Jobs, Security, Maintenance, and Support. The 'Support' category is highlighted in blue. The main content area is divided into sections: 'Device Information' showing Part Number (312320-3R-01), Serial (27042), Base Version (4.5.4.3), and GDK Version (ToolAsm 1.0.0.23); 'Support File' with a text area for filename (set to 'support') and description, and a 'Download' button; 'User Manual' with 'Open HTML' and 'Download PDF' buttons; and 'Software Development Kit (SDK)' with a 'Download' button.

Common Programming Operations

The following sections describe common programming operations.

Input Data Objects

The `VProcess` function receives a `GdkToolInput` object as input. This object is a container where the information and actual data of the received input is stored.

```
GdkInputItem item = GdkToolInput_Find(input, obj->dataSource);  
GdkDataInfo itemInfo = GdkInputItem_Info(item);
```

The `GdkToolInput_Find` and `GdkInputItem_Info` functions are used to extract the item and info objects. These objects can then be used to retrieve the input data and information (for example, offset and resolution) associated to the input. The following are some examples:

Computing actual height information using offset and scale

```
k64f height = rangeSrc[index] * scale->z + offset->z;
```

Extracting height information from profiles and surfaces.

The `TestProfileSelect` and `TestSurfaceSelect` examples show how to perform these operations.

Setup and Region Info during Tool Initialization

Memory allocation is often done in the `VInit` or `VStart` function. To retrieve sensor and data information such as active area settings and data scale outside of `VProcess`, you can use the following function:

```
GdkDataInfo info = GdkSensorInfo_DataSource(GdkTool_SensorInfo(tool), GDK_DATA_SOURCE_TOP);
```

Computing Region Based on the Offset from an Anchor Source

Just like built-in measurement tools, custom tools created with the GDK can be anchored to another tool (GDK-based tools or built-in tools).

To compute the offset region:

```
TestToolClass* obj = TestTool_Cast_(tool);
GdkParams params = GdkToolCfg_Parameters(config);
const kPoint3d64f* anchor = GdkToolInput_AnchorPosition(input);
GdkRegionXZ64f offsetRegion = { k64F_NULL, k64F_NULL, k64F_NULL, k64F_NULL };

param = GdkParams_Find(params, "Region");
obj->region = *GdkParam_AsProfileRegion(param);

offsetRegion = obj->region;
offsetRegion.x += anchor->x;
offsetRegion.z += anchor->z;
```

In the code above, we first retrieve the tool's region settings (before anchoring is applied), and then adjust the region based on the results from the anchored source in `VProcess`. If the anchored source fails, the tools will not be invoked.

The `TestProfileSelect` and `TestSurfaceSelect` examples show how to extract height information from anchored regions.

For more information on anchoring, see *Measurement Anchoring* in the Gocator user manual.

Part Matching

When part matching is enabled, the tool receives translated and corrected surface data. If part matching fails for the current scan (for example, the quality score is too low), the tools will not be invoked.

For more information on part matching, see *Part Matching* in the user manual.

Accessing Sensor Local Storage

You can access a sensor's local storage by using the `kFile` API.

For example, to read and write a file to a sensor's storage, you could use the following:

```

#include <kApi/Io/kFile.h>

...

ToolFx(kStatus) TestTool_VStart(TestTool tool)
{
    ...

    kFile_Save("test.txt", stringBuffer, (kSize) 1024);
    kFile_Load("test.txt", stringBuffer, &bufLen, kNULL);
}

```

Print Output

In the emulator, you can send output to Visual Studio or to programs such as DebugView by using the `OutputDebugString` function.

```

GtsFx(kStatus) TestTool_Trace(const kChar* format, ...)
{
    kStatus status = kOK;
    kChar debugLine[256];

    kVarArgList argList;
    kVarArgList_Start_(argList, format);
    {
        status = kStrPrintf(debugLine, 256, format, argList);
    }
    kVarArgList_End_(argList);
    OutputDebugStringA(debugLine);
    return status;
}

```



`OutputDebugString` is NOT supported on sensor targets. Use `#ifdef` to comment out the code when compiling against sensor targets.

Tools

The following sections describe the tools you can use with a Gocator.

Sensor Discovery Tool

If a sensor's network address or administrator password is forgotten, the sensor can be discovered on the network and/or restored to factory defaults by using the Sensor Discovery software tool. This tool can be obtained from the downloads area of the LMI Technologies website: <http://www.lmi3D.com>.

After downloading the utility package [14405-x.x.x.x_SOFTWARE_GO_Uutilities.zip], unzip the file and run the Sensor Discovery Tool [Tools > Discovery > kDiscovery.exe].

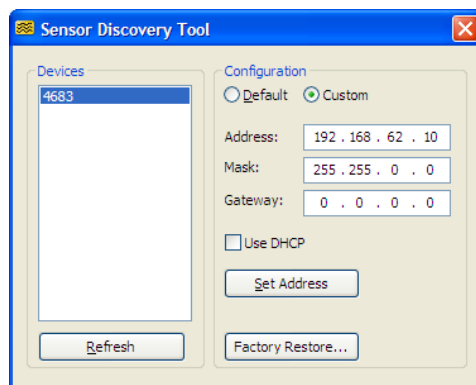

Any sensors that are discovered on the network will be displayed in the Devices list.

To change the network address of a sensor:

1. Select the **Custom** option.
2. Enter the new network address information.
3. Click **Set Address**.

To restore a sensor to factory defaults:

1. Select the sensor serial number in the **Devices** list.
2. Press the **Factory Restore...** button.
Confirm when prompted.





The Sensor Discovery tool uses UDP broadcast messages to reach sensors on different subnets. This enables the Sensor Discovery tool to locate and re-configure sensors even when the sensor IP address or subnet configuration is unknown.

CSV Converter Tool

The CSV Converter tool lets you convert data exported from a Gocator sensor in the CSV format to several formats (see table below). For more information on exporting recorded data, see *Downloading, Uploading, and Exporting Replay Data* on page 66.

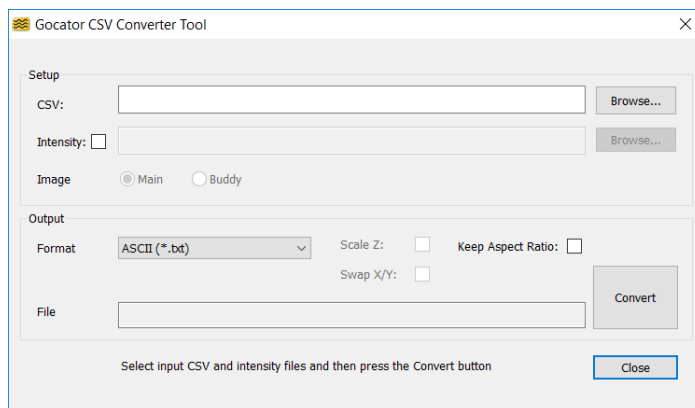
For information on the CSV file format that the sensor exports, see the next section.



 The tool supports data exported from Profile mode.

To get the utility package (), go to <http://lmi3d.com/support>, choose your product from the Product Downloads section, and download it from the Download Center.

After downloading the tool package, unzip the file and run the Gocator CSV Converter tool [Tools > CSV Converter > kCsvConverter.exe].

The tool supports the following output formats:

Output formats

Format	Description
ASCII (XYZI)	Comma-separated points in X, Y, Z, Intensity (if available) format.
16-bit BMP	Heightmap with 16bit height values in a 5-5-5 RGB image. Not intended for visualization.
16-bit TIFF	Heightmap as grayscale image.
16-bit PNG	Heightmap as grayscale image.
GenTL RGB	Not intended for use with this sensor family.
GenTL Mono	Not intended for use with this sensor family.
Raw CSV	LMI Gocator CSV format for a single frame.
HexSight HIG	LMI HexSight heightmap.
STL ASCII	Mesh in standard STL text format (can become very large).
STL Binary	Mesh in binary STL format.
Wavefront OBJ	Mesh with comma-separated vertices and facets in text

Format	Description
	format.
ODSCAD OMC	ODSCAD heightmap.
MountainsMap SUR	DigitalSurf MountainsMap heightmap.
24-bit Spectrum	Color spectrum bitmap for visualization of heightmap. Does not contain height values.

With some formats, one or more of the following options are available:

Output options

Option	Description
Scale Z	Resamples the Z values to use the full value range.
Swap X/Y	Swaps the X and Y axes to obtain a right-handed coordinate system.
Keep Aspect Ratio	Resamples the X and Y axes to obtain the proper aspect ratio.

To convert exported CSV into different formats:

1. Select the CSV file to convert in the **CSV** field.
2. (Optional) If intensity information is required, check the **Intensity** box and select the intensity bitmap. Intensity information is only used when converting to ASCII or GenTL format. If intensity is not selected, the ASCII format will only contain the point coordinates (XYZ).
3. If a dual-sensor system was used, choose the source sensor next to **Image**.
4. Select the output format.
For more information on output formats, see *Output formats* on the previous page.
5. (Optional) Set the **Scale Z**, **Swap X/Y**, and **Keep Aspect Ratio** options.
Availability of these options depends on the output format you have chosen. For more information, see *Output options* above.
6. Click **Convert**.
The converter converts the input files.

The converted file will be in the same directory as the input file. It will also have the same name as the input file but with a different file extension. The converted file name is displayed in the **Output File** field.

CSV File Format

The CSV Converter tool can convert from the CSV format that a sensor can export to several other formats. If you want to work with the exported file directly, use the following information.

An exported CSV file contains a series of "sections." Each section begins with a row containing the name of the section, and ends with a row containing the string "End." An empty line separates each section.

Each section usually contains one or more subsections. Each subsection has a header row containing a list of field names, followed by one or more rows of data. There is usually no empty line between the subsections.

Other structures within sections are possible.

Example:

```
Info
CSV Version,Sensor Count,Trigger Mode,...
2,1,0,32000.00000,...
End
```

```
DeviceInfo
ID,Model,Version,...
13434,311320-2M-01,4.8.2.29,...
End
```

```
Ranges
...
End
```

Info

This section contains basic system information. It has one header row and one value row. The fields are described below:

Info Fields

Field	Description
CSV Version	Version of the CSV file format.
Sensor Count	Number of sensors in the system.
Trigger Mode	Trigger source: 0 – Time 1 – Encoder 2 – Digital input 3 – Software
Trigger Rate	Frame rate for time trigger (Hz).
Trigger Delay Domain	Output delay domain: 0 – Time (µs) 1 – Encoder (mm)
Trigger Delay	Output delay (µs or mm, depending on delay domain defined above).
Operation Mode	The scan mode.
XResolution	System X resolution (mm).
YResolution	System Y resolution (mm).

Field	Description
ZResolution	System Z resolution (mm).
Yspeed	Y Speed (mm/s).
Layout	Sensor orientation: 0 – Normal (single-sensor system) / Wide (dual-sensor system) 1 – Opposite 2 – Reverse 3 – Grid

DeviceInfo

This section contains information about each device in the system. There is one header row, and one value row per device.

DeviceInfo Fields

Field	Description
ID	Device serial number
Model	Device part number
Version	Firmware version
Exposure Mode	Exposure mode: 0 – Single exposure 1 – Multiple exposures 2 – Dynamic exposure
Exposure 0 through Exposure 4	Multiple exposures
Exposure Min	Dynamic exposure min
Exposure Max	Dynamic exposure max
FOV X	Active area X
FOV Y	Active area Y
FOV Z	Active area Z
FOV Width	Active area width
FOV Height	Active area length (Y). (Note difference in terminology.)
FOV Depth	Active area height (Z). (Note difference in terminology.)
Transform X	Transform X offset (mm)
Transform Y	Transform Y offset (mm)
Transform Z	Transform Z offset (mm)
Transform X Angle	Transform X Angle (degrees)
Transform Y Angle	Transform Y angle (degrees)
Transform Z Angle	Transform Z angle (degrees)

RecordingFilter

This section lists the filters used during recording. Unlike the other sections, it contains multiple sub-

sections within, separated by spaces (but not the “End” keyword).

Example:

```
RecordingFilter
Section1 Param 1, Section1 Param2
value, value
Section2 Param 1
value
Section3 Param1, Section3 Param2
value
End
```

Each section will be described by a separate table below. They appear in the same order as documented.

RecordingFilter Fields

Field	Description
Condition Combination Type	Any or All

"Any Measurement" Filter Fields

Field	Description
Type	Any Measurement
Enabled	Whether or not is enabled. Yes/No
Result	Accepted result type: Pass/Fail/Invalid/Valid

"Any Data" Filter Fields

Field	Description
Type	Any Data
Enabled	Whether or not is enabled: Yes/No
Threshold Case	How to threshold: At or Above, or Below
Range Count Threshold	Threshold value (point count)

"Measurement" Filter Fields

Field	Description
Type	Measurement
Enabled	Whether or not is enabled: Yes/No
Result	Accepted result type: Pass/Fail/Invalid/Valid
Selection ID	First measurement ID

Ranges

This section describes single-point range data. It has two sub-sections: attributes and data.

The attribute section has only one row of data

Attribute Section Fields

Field	Description
Frame Count	Total number of frames
X Offset	X offset (mm)
Y Offset	Y offset (mm)
Z Offset	Z offset (mm)

The data section has one or more rows of data per frame (for example, range and intensity).

Data Section Fields

Field	Description
Frame	Frame index
Source	Source (for example, 0 for Top)
Time	Stamp time
Encoder	Stamp encoder
Z Encoder	Stamp encoder Z
Inputs	Stamp inputs
Exposure	Stamp exposure (us)
Y	Y value (mm)
Axis	Axis: Z (range) or I (Intensity)
Value	Range value (mm) or intensity (count)

Profile

This section describes uniform (or resampled) profile data, which is produced when the sensor is in Profile mode and uniform spacing is enabled. It has two sub-sections: attributes and data.

The attribute section has only one row of data.

Attribute Section Fields

Field	Description
Frame Count	Total number of frames
Column Count	Number of columns
X Offset	X offset (mm)
Y Offset	Y offset (mm)
Z Offset	Z offset (mm)

The data section has one or more rows of data per frame (for example, range and intensity).

Data Section Fields

Field	Description
Frame	Frame index
Source	Source (for example, 0 for Top)

Field	Description
Time	Stamp time
Encoder	Stamp encoder
Z Encoder	Stamp encoder Z
Inputs	Stamp inputs
Exposure	Stamp exposure (μ s)
Y	Y value (mm)
Axis	Axis: Z (range) or I (Intensity)
(x values)	Each column in header is a resampled X position Each column in data is the range (mm) or intensity (count)

RawProfile

This section describes point cloud profile data (or unresampled / raw data), which is produced when the sensor is in Profile mode and uniform spacing is disabled. It has two sub-sections: attributes and data.

The attribute section has only one row of data.

Attribute Section Fields

Field	Description
Frame Count	Total number of frames
Column Count	Number of columns
X Offset	X offset (mm)
Y Offset	Y offset (mm)
Z Offset	Z offset (mm)

The data section has one or more rows of data per frame (for example, range and intensity).

Data Section Fields

Field	Description
Frame	Frame index
Source	Source (for example, 0 for Top)
Time	Stamp time
Encoder	Stamp encoder
Z Encoder	Stamp encoder Z
Inputs	Stamp inputs
Exposure	Stamp exposure (μ s)
Y	Y value (mm)
Axis	Axis: X, Z, or I (Intensity)
(x values)	Each column in header is an index. Each column in data is the X/Z value (mm) or intensity (count)

Troubleshooting

Review the guidance in this chapter if you are experiencing difficulty with a sensor system.

If the problem that you are experiencing is not described in this section, see *Return Policy* on page 567.

Mechanical/Environmental

The sensor is warm.

- It is normal for a sensor to be warm when powered on. A sensor is typically 15° C warmer than the ambient temperature.

Connection

When attempting to connect to the sensor with a web browser, the sensor is not found (page does not load).

- Verify that the sensor is powered on and connected to the client computer network. The Power Indicator LED should illuminate when the sensor is powered.
- Check that the client computer's network settings are properly configured.
- Use the Sensor Recovery tool to verify that the sensor has the correct network settings. See *Sensor Discovery Tool* on page 504 for more information.

When attempting to log in, the password is not accepted.

- Use the Sensor Recovery tool. See *Sensor Discovery Tool* on page 504 for steps to reset the password.

The sensor emits laser light, but the Range Indicator LED does not illuminate and/or points are not displayed in the Data Viewer.

- Verify that the measurement target is within the sensor's field of view and measurement range. See *Specifications* on page 513 to review the measurement specifications for your sensor model.
- Check that the exposure time is set to a reasonable level. See *Exposure* on page 101 for more information on configuring exposure time.

Performance

The sensor CPU level is near 100%.

- Consider reducing the speed. If you are using a time or encoder trigger source, see *Triggers* on page 91 for information on reducing the speed. If you are using an external input or software trigger, consider reducing the rate at which you apply triggers.
- Review the measurements that you have programmed and eliminate any unnecessary measurements.

Specifications

The following sections describe the specifications of Gocator sensors and connectors, as well as Master hubs.

Sensors

The following sections provide the specifications of Gocator sensors.

Gocator 1300 Series

The Gocator 1300 series consists of the following models:

MODEL	1320	1340	1350	1365	1370	1380	1390
Clearance Distance (mm)	40	162.5	200	562	237.5	127	500
Measurement Range (MR) (mm)	20	95	200	375	412.5	1651	2000
Linearity Z (+/- % of MR)	0.05	0.05	0.05	0.11	0.07	0.18	0.10
Linearity Z (+/- mm)	0.010	0.05	0.100	0.4	0.3	3.0	2.0
Resolution Z (mm)	0.0004 - 0.0004	0.0005 - 0.0010	0.0015 - 0.0035	0.0025 - 0.0040	0.0025 - 0.0070	0.0100 - 0.0450	0.0250 - 0.0600
Spot Size (mm)	0.11	0.37	0.50	1.80	0.90	2.60	2.60
Recommended Laser Class	3R	3B	3B	3B	3B	3B	3B
Other Laser Class	3B	2M, 3R					
Recommended Package Dimensions (mm)	Side Mount (3R) 30x120x149	Side Mount 30x120x149	Side Mount 30x120x149	Side Mount 30x120x220	Side Mount 30x120x149	Side Mount 30x120x149	Side Mount 30x120x277
Other Package Dimensions (mm)	Top Mount (3B) 49x75x162		Top Mount 49x75x162				
Weight (kg)	0.8	0.8	0.75 / 0.8	1.1	0.8	0.8	1.4

The following diagram illustrates some of the terms used in the table above.

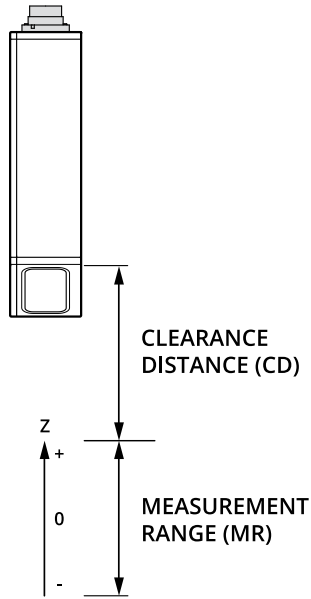

Optical models, laser classes, and packages can be customized. Contact LMI for more details.

Specifications stated are based on standard laser classes. Linearity Z and Resolution Z may vary for other laser classes.

All specification measurements are performed on LMI's standard calibration target (a diffuse, painted white surface).

Linearity Z is the worst case difference in average height measured, compared to the actual position over the measurement range.

Resolution Z is the maximum variability of height measurements across multiple frames, with 95% confidence.

See *Resolution and Accuracy* on page 52 for more information.

ALL 1300 SERIES MODELS

Scan Rate	32kHz
Interface	Gigabit Ethernet
Inputs	Differential Encoder, Laser Safety Enable, Trigger
Outputs	2x Digital Output, RS-485 Serial, Selcom Serial, 1x Analog Output (4 - 20 mA)
Input Voltage (Power)	+24 to +48 VDC (13 Watts); Ripple +/- 10%
Housing	Gasketed Aluminum Enclosure, IP67
Operating Temp.	0 to 50° C
Storage Temp.	-30 to 70 ° C

Mechanical dimensions, CD/MR, and the envelope for each sensor model are illustrated on the following pages.

Gocator 1320 (Side Mount Package)

Measurement Range

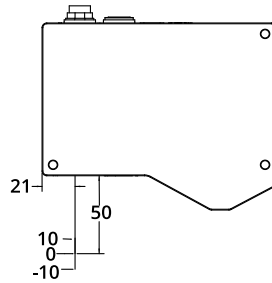

Dimensions

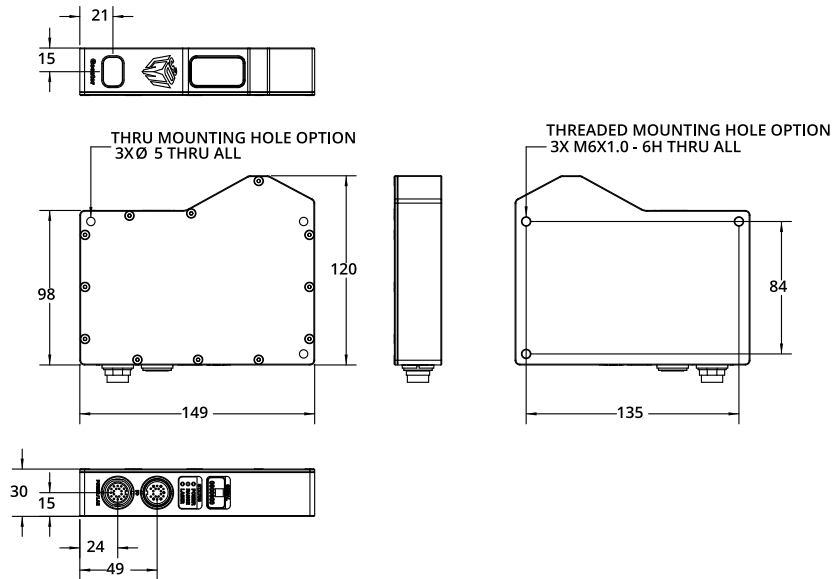

Envelope

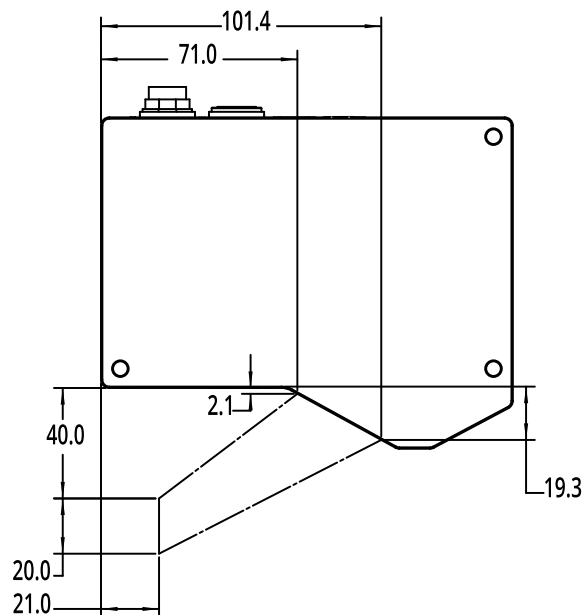

Gocator 1320 (Top Mount Package)

Field of View / Measurement Range

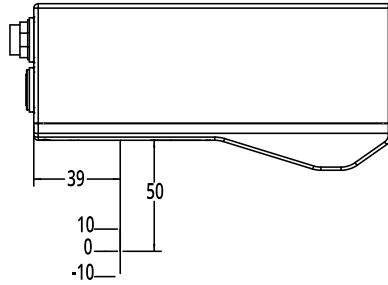

Dimensions

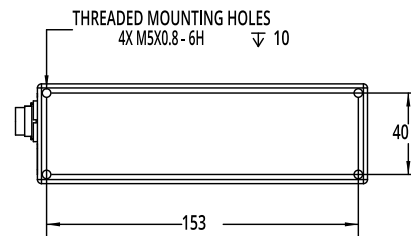
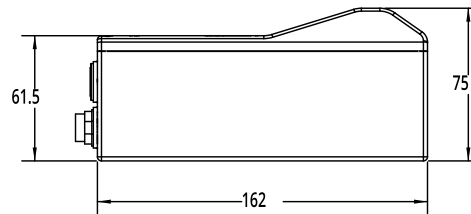
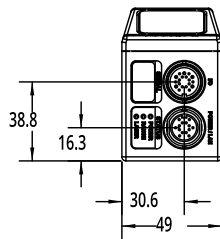
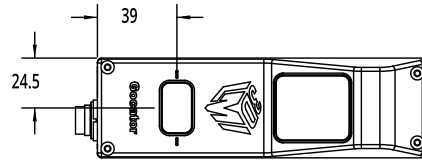

Envelope

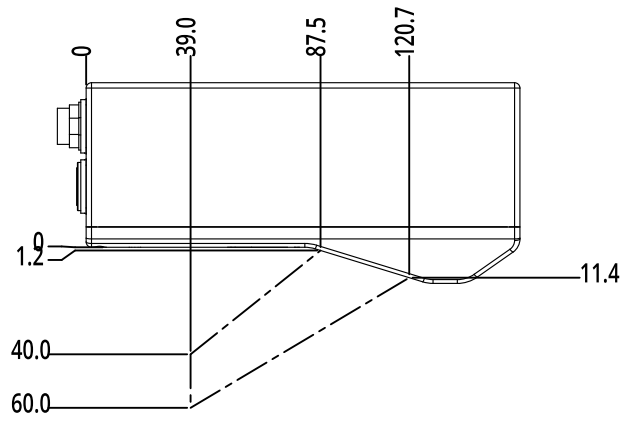

Gocator 1340 (Side Mount Package)

Measurement Range

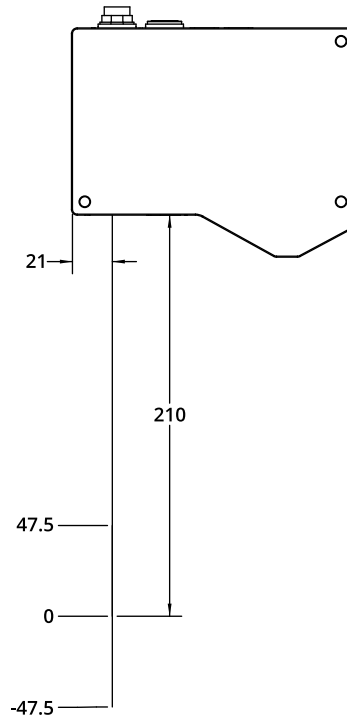

Dimensions

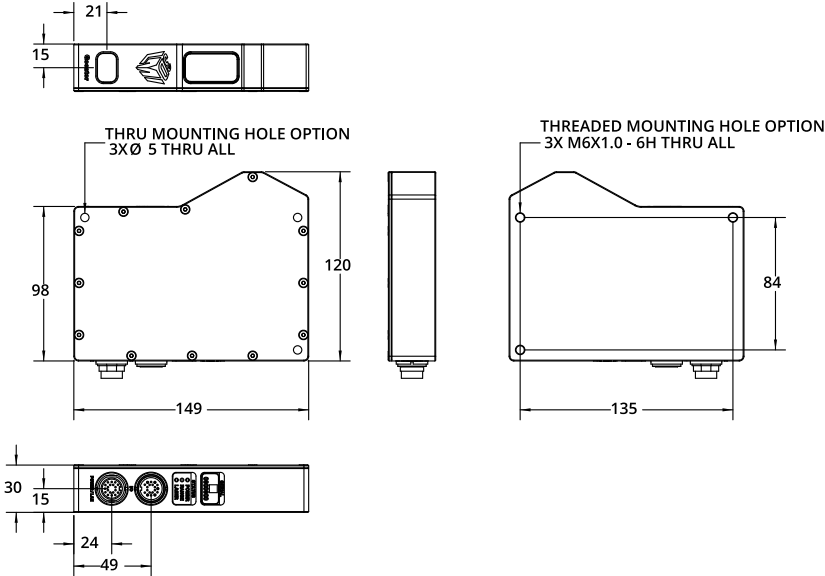

Envelope

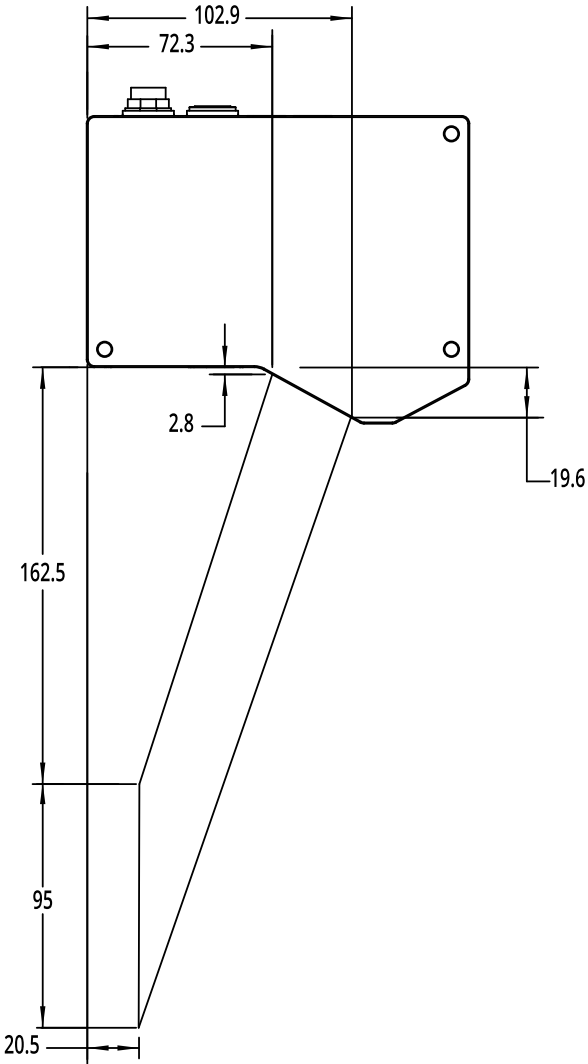

Gocator 1350 (Side Mount Package)

Measurement Range

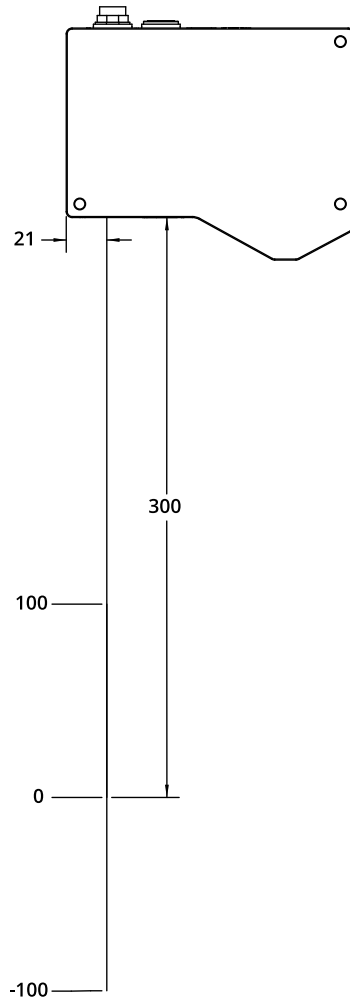

Dimensions

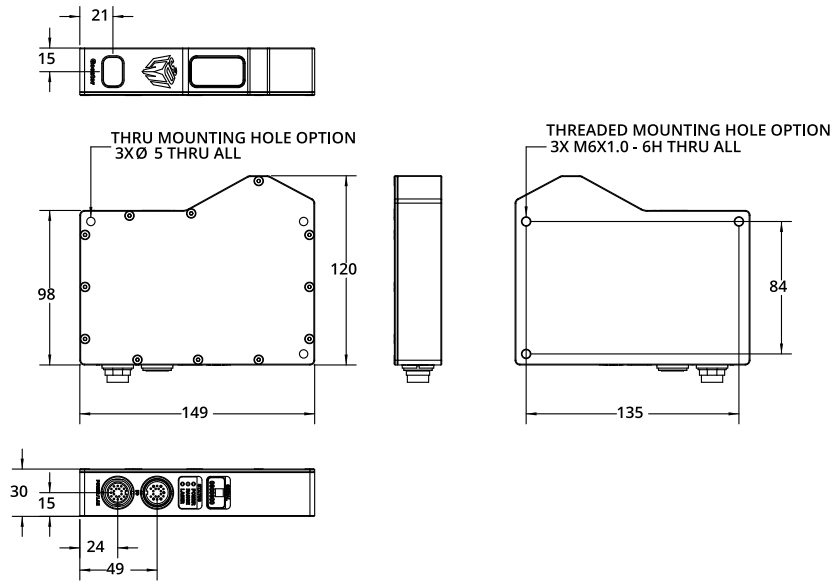

Envelope

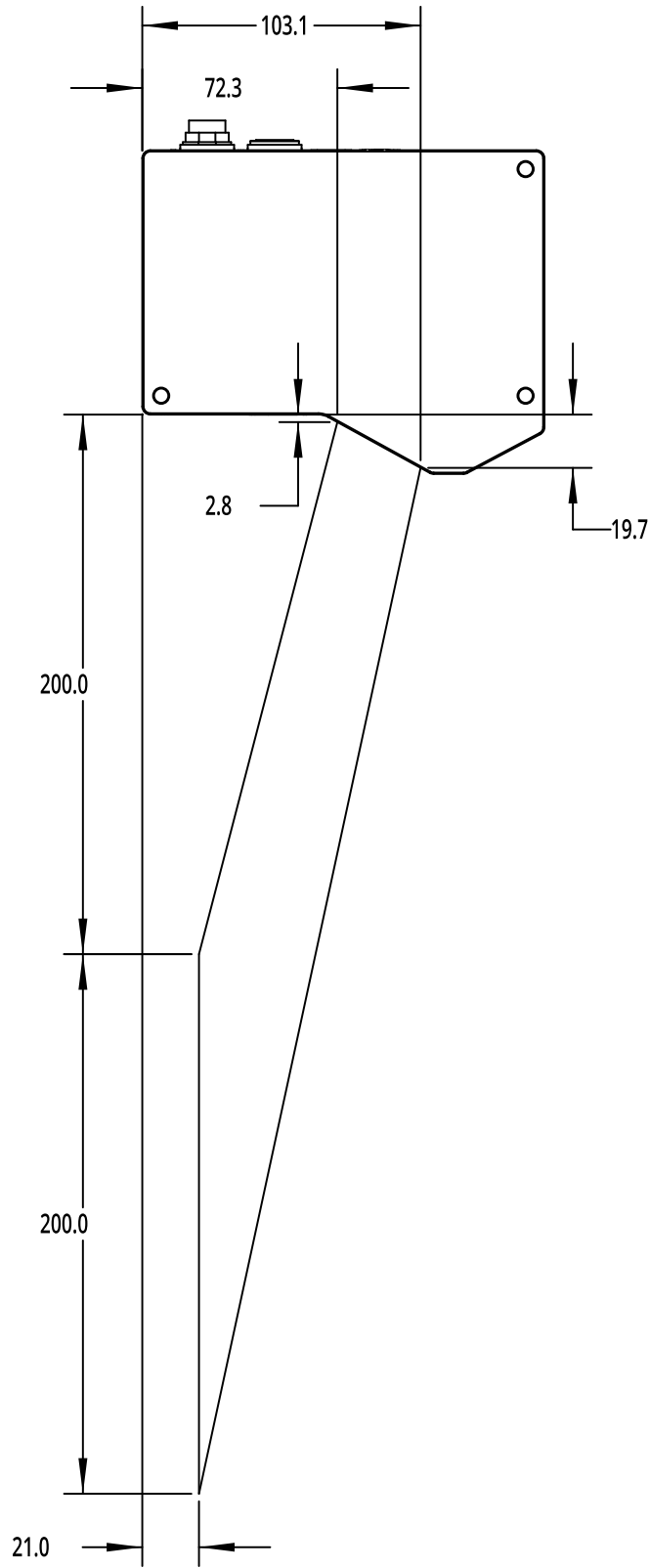

Gocator 1350 (Top Mount Package)

Measurement Range

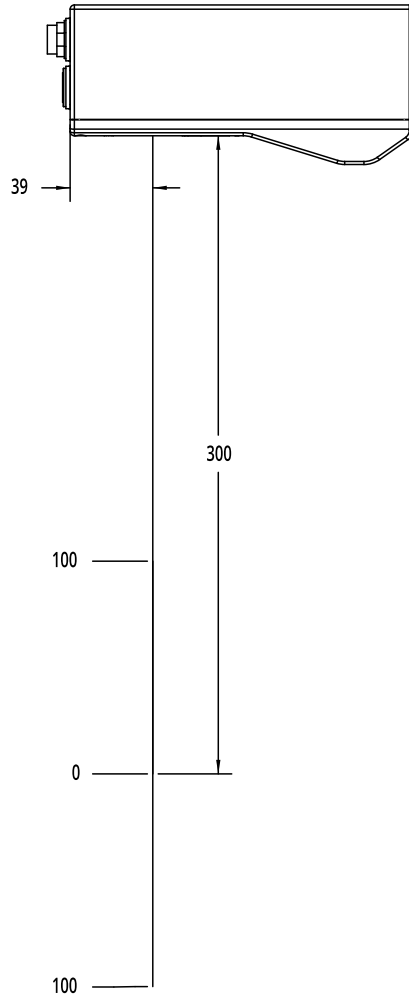

Dimensions

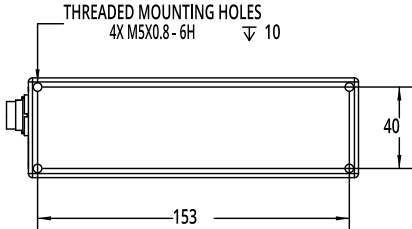
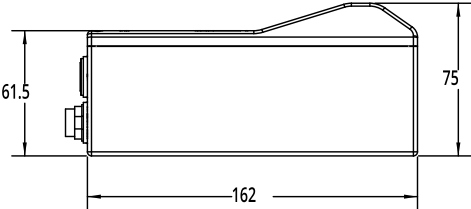
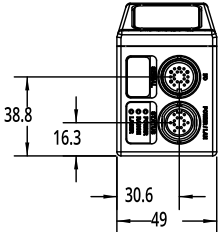
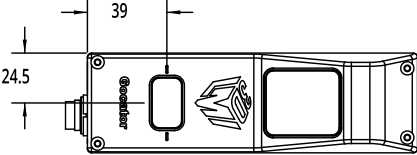

Envelope

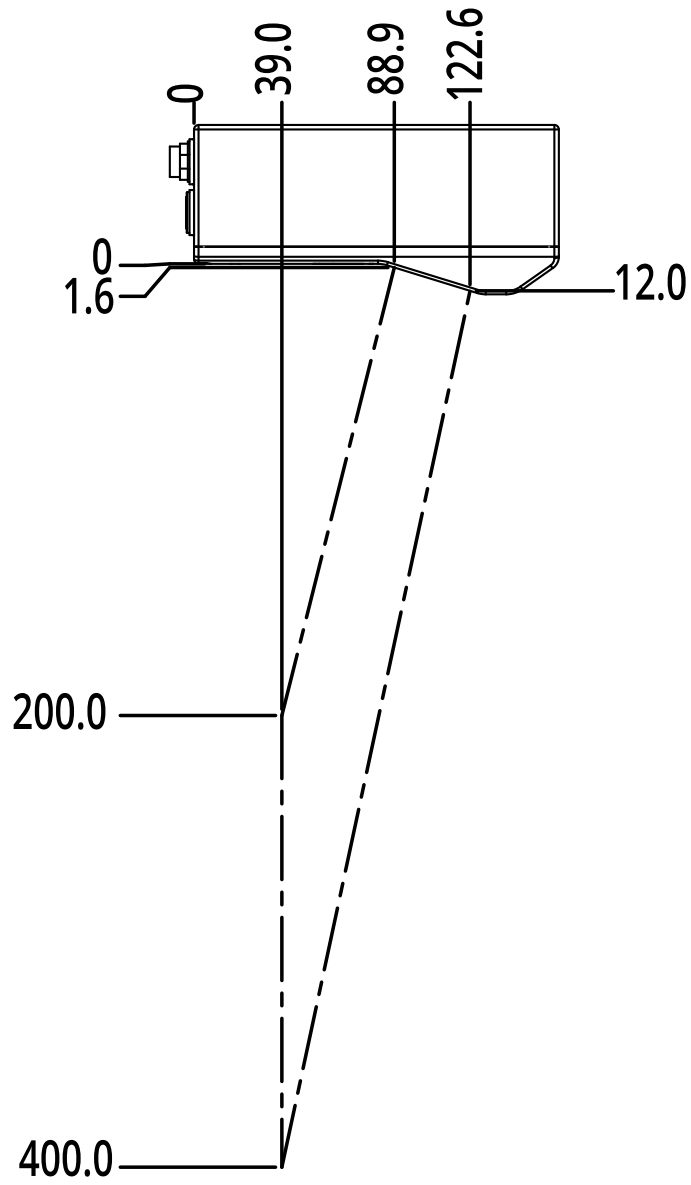

Gocator 1365 (Side Mount Package)

Measurement Range

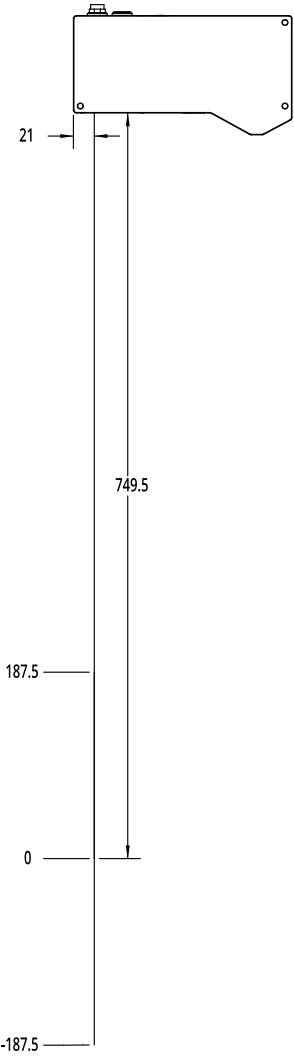

Dimensions

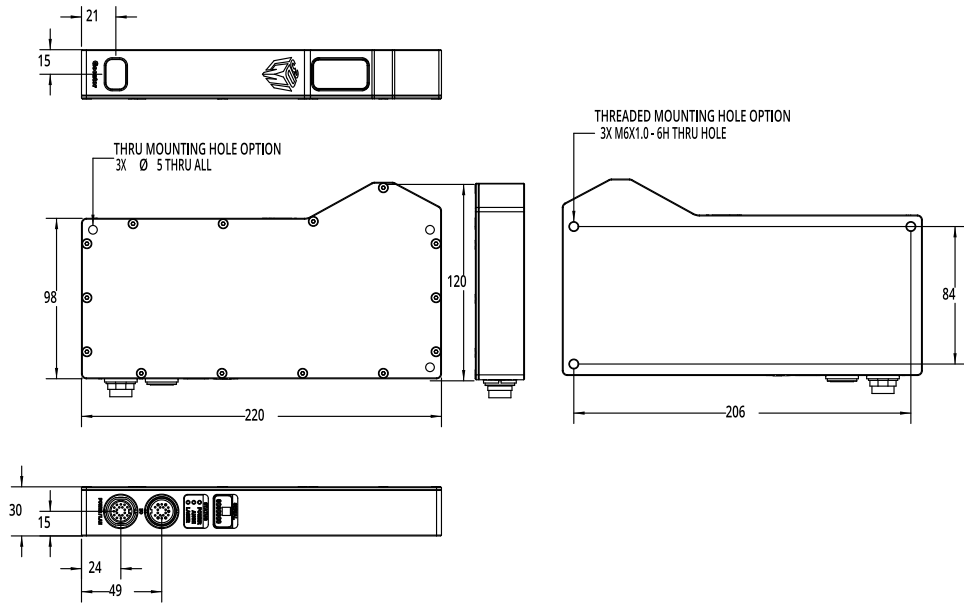

Envelope

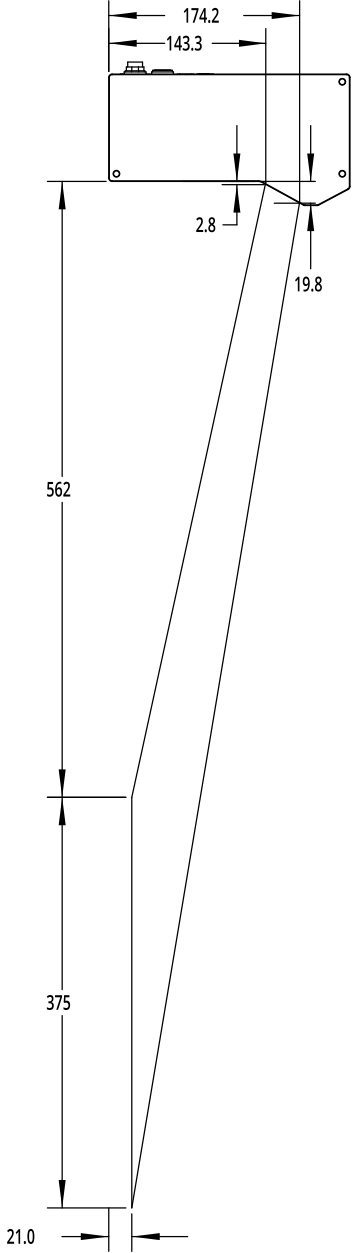

Gocator 1370 (Side Mount Package)

Measurement Range

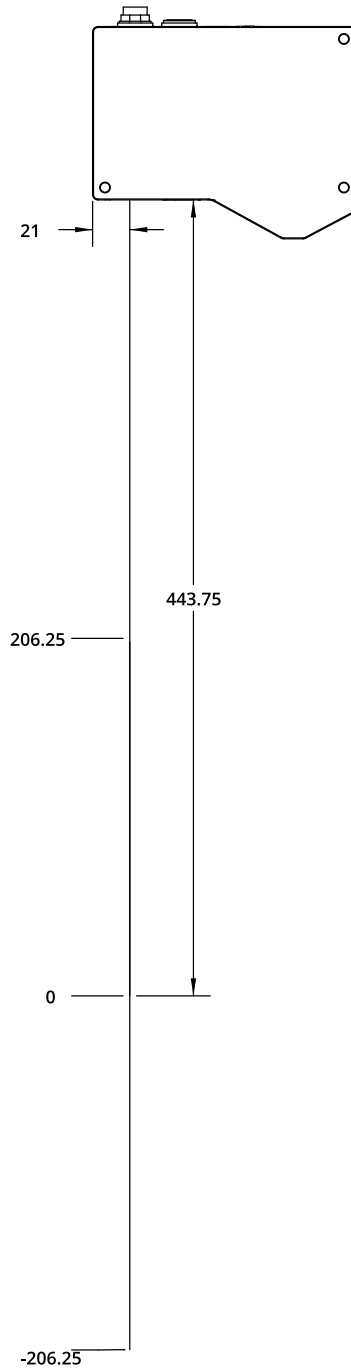

Dimensions

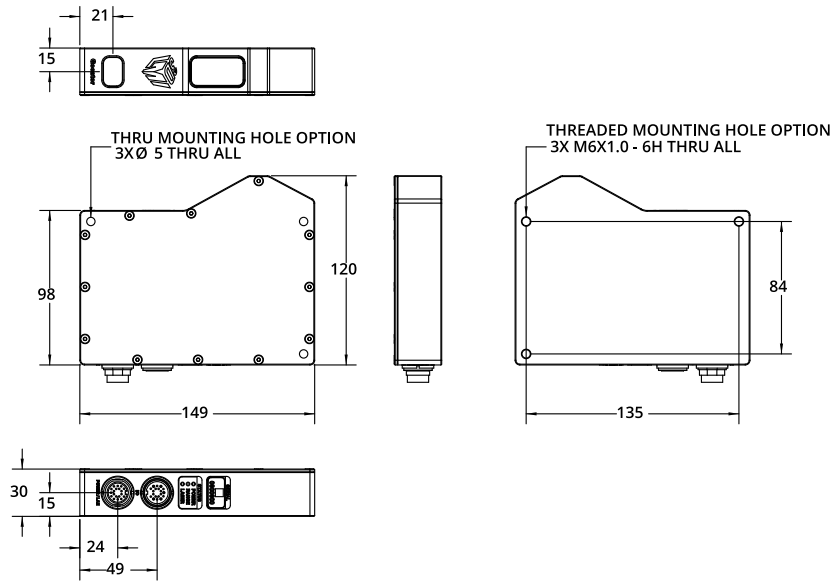

Gocator 1380 (Side Mount Package)

Measurement Range

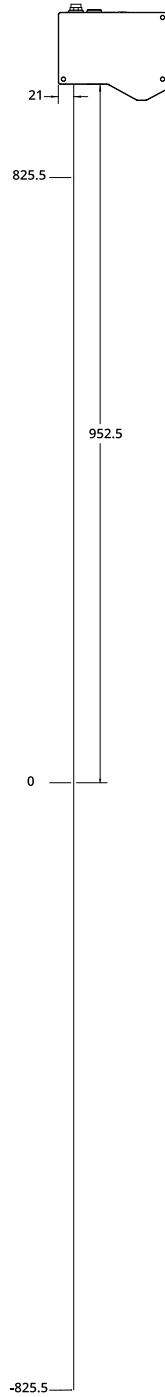

Dimensions

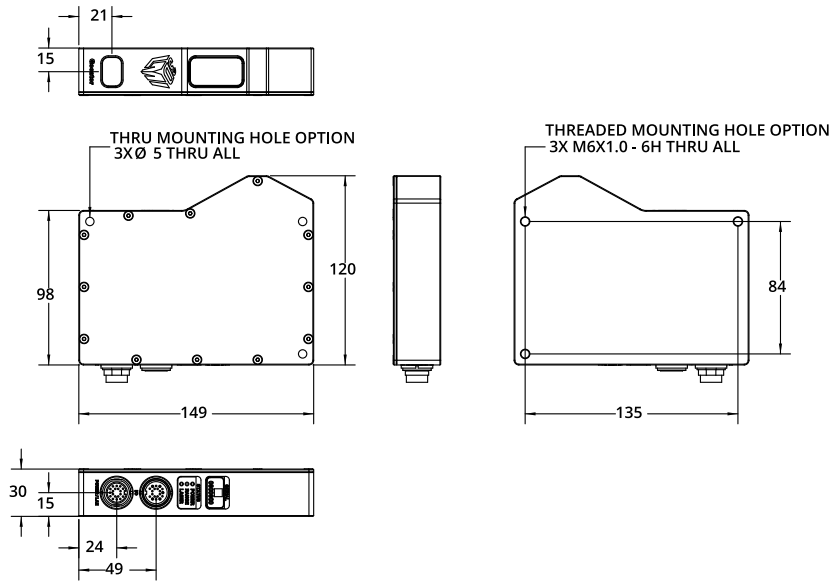

Envelope

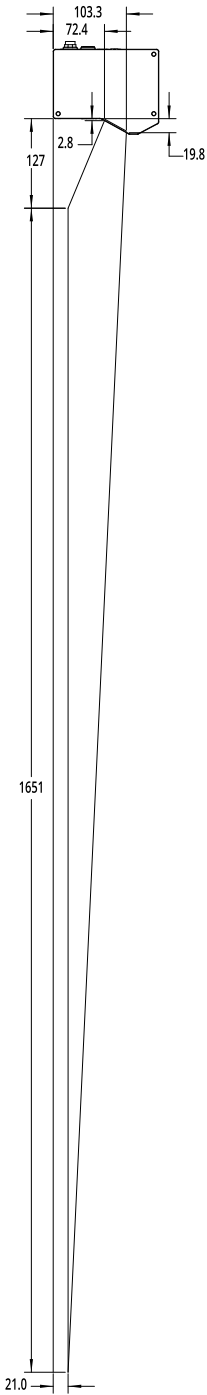

Gocator 1390 (Side Mount Package)

Measurement Range

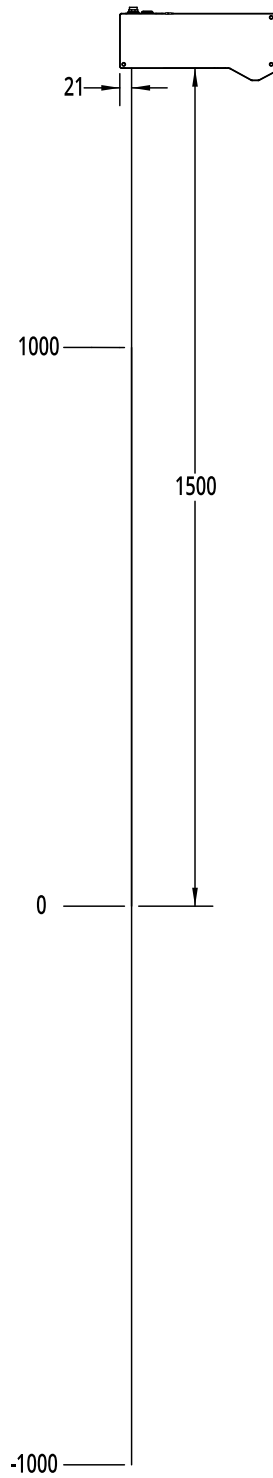

Dimensions

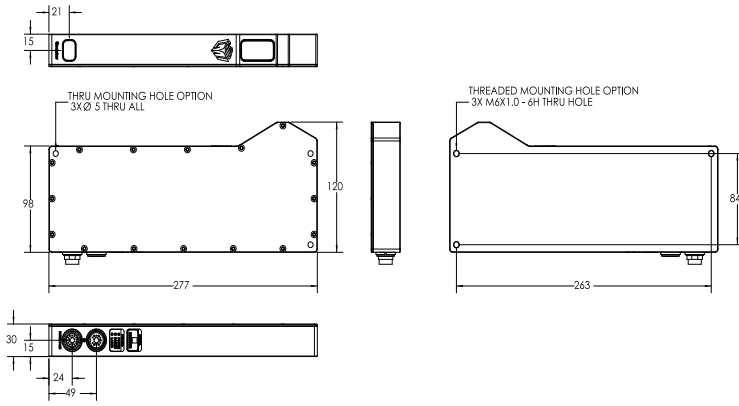

Envelope

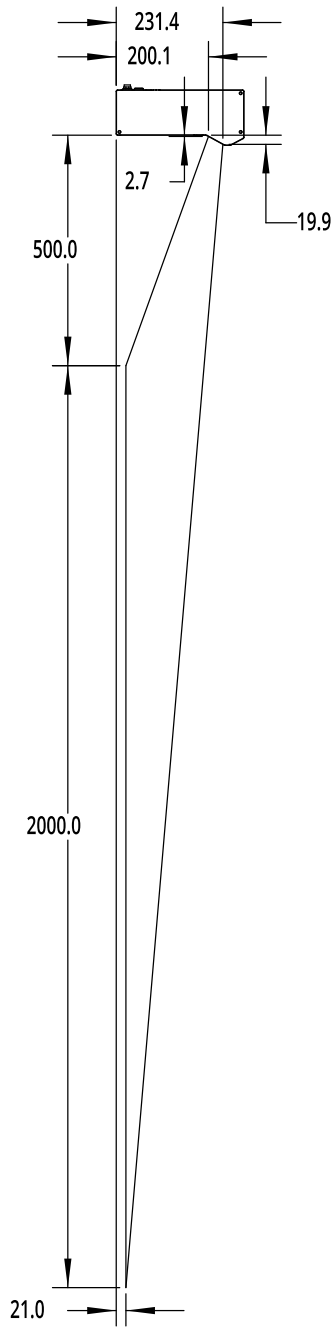

Sensor Connectors

The following sections provide the specifications of the connectors on Gocator sensors.

Gocator Power/LAN Connector

The Power/LAN connector is a 14 pin, M16 style connector that provides power input, laser safety input, and Ethernet.

 This connector is rated IP67 only when a cable is connected or when a protective cap is used.

This section defines the electrical specifications for Power/LAN Connector pins, organized by function.

Gocator Power/LAN Connector Pins

Function	Pin	Lead Color on Standard Cordsets	Lead Color on High Flex Cordsets
GND_24-48V	L	White / Orange & Black	Orange / Red
GND_24-48V	L	Orange / Black	Orange / Black
DC_24-48V	A	White / Green & Black	Green / Red
DC_24-48V	A	Green/ Black	Green / Black
Safety-	G	White / Blue & Black	Blue / Black
Safety+	J	Blue / Black	Blue / Red
Sync+	E	White / Brown & Black	Brown / Red (not connected)
Sync-	C	Brown / Black	Brown / Black (not connected)
Ethernet MX1+	M	White / Orange	White / Orange
Ethernet MX1-	N	Orange	Orange
Ethernet MX2+	O	White/ Green	White / Green
Ethernet MX2-	P	Green	Green
Ethernet MX3-	S	White / Blue	White / Blue
Ethernet MX3+	R	Blue	Blue
Ethernet MX4+	T	White / Brown	White / Brown
Ethernet MX4-	U	Brown	Brown

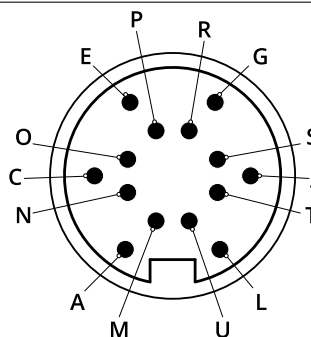

View: Looking into the connector **on** the sensor

Two wires are connected to the ground and power pins.

Grounding Shield

The grounding shield should be mounted to the earth ground.

Power

Apply positive voltage to DC_24-48V.

Power requirements

Function	Pins	Min	Max
DC_24-48V	A	24 V	48 V
GND_24-48VDC	L	0 V	0 V

Laser Safety Input

The Safety_in+ signal should be connected to a voltage source in the range listed below. The Safety_in- signal should be connected to the ground/common of the source supplying the Safety_in+.

Laser safety requirements

Function	Pins	Min	Max
Safety_in+	J	24 V	48 V
Safety_in-	G	0 V	0 V



Confirm the wiring of Safety_in- before starting the sensor. Wiring DC_24-48V into Safety_in- may damage the sensor.

Gocator I/O Connector

The Gocator I/O connector is a 19 pin, M16 style connector that provides encoder, digital input, digital outputs, serial output, and analog output signals.



This connector is rated IP67 only when a cable is connected or when a protective cap is used.

This section defines the electrical specifications for I/O connector pins, organized by function.

Gocator I/O Connector Pins

Function	Pin	Lead Color on Standard Cordset	Lead Color on High Flex Cordset
Trigger_in+	D	Grey	Blue / Red
Trigger_in-	H	Pink	Blue / Black
Out_1+ (Digital Output 0)	N	Red	Brown / Red
Out_1- (Digital Output 0)	O	Blue	Brown / Black
Out_2+ (Digital Output 1)	S	Tan	Green / Red
Out_2- (Digital Output 1)	T	Orange	Green / Black
Encoder_A+	M	White / Brown & Black	Pink / Red
Encoder_A-	U	Brown / Black	Pink / Black
Encoder_B+	I	Black	Yellow / Red
Encoder_B-	K	Violet	Yellow / Black
Encoder_Z+	A	White / Green & Black	White / Red
Encoder_Z-	L	Green / Black	White / Black
Serial_out+	B	White	Purple / Red
Serial_out-	C	Brown	Purple / Black
Serial_out2+	E	Blue / Black	Red
Serial_out2-	G	White / Blue & Black	Black
Analog_out+ (Reserved on Gocator 2500 series sensors)	P	Green	Gray / Red
Analog_out- (Reserved on Gocator 2500 series sensors)	F	Yellow & Maroon / White	Gray / Black & Orange / Black
Reserved	R	Maroon	Orange / Red (not connected)

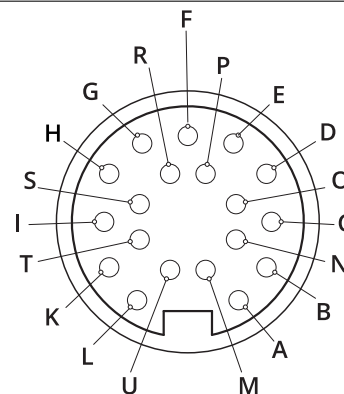

View: Looking into the connector **on** the sensor

Grounding Shield

The grounding shield should be mounted to the earth ground.

Digital Outputs

Each sensor has two optically isolated outputs. Both outputs are open collector and open emitter, which allows a variety of power sources to be connected and a variety of signal configurations.

 Digital outputs cannot be used when taking scans using the Snapshot button, which takes a single scan and is typically used to test measurement tool settings. Digital outputs can only be used when a sensor is running, taking a continuous series of scans.

Out_1 (Collector – Pin N and Emitter – Pin O) and Out_2 (Collector – Pin S and Emitter – Pin T) are independent and therefore V+ and GND are not required to be the same.

Function	Pins	Max Collector Current	Max Collector-Emitter Voltage	Min Pulse Width
Out_1	N, O	40 mA	70 V	20 μ s
Out_2	S, T	40 mA	70 V	20 μ s

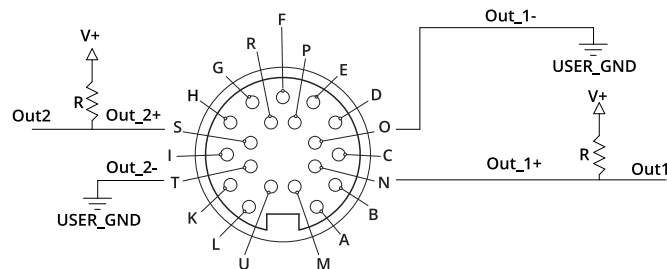

The resistors shown above are calculated by $R = (V+) / 2.5 \text{ mA}$.

The size of the resistors is determined by power = $(V+)^2 / R$.

Inverting Outputs

To invert an output, connect a resistor between ground and Out_1- or Out_2- and connect Out_1+ or Out_2+ to the supply voltage. Take the output at Out_1- or Out_2-. For resistor selection, see above.

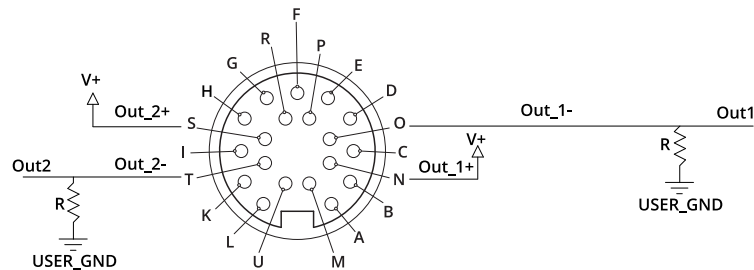

Digital Input

Every sensor has a single optically isolated input. To use this input without an external resistor, supply 3.3 - 24 V to the positive pin and GND to the negative.

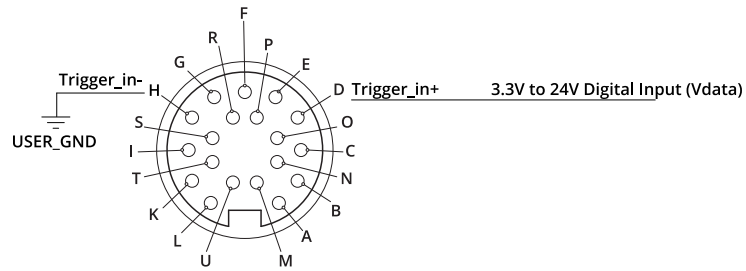

Active High

If the supplied voltage is greater than 24 V, connect an external resistor in series to the positive. The resistor value should be $R = [(V_{in} - 1.2V) / 10mA] - 680$.

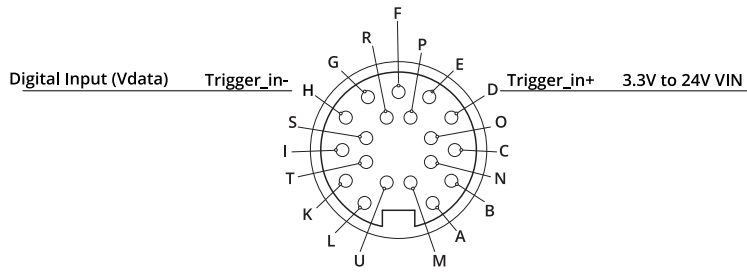

Active Low

To assert the signal, the digital input voltage should be set to draw a current of 3 mA to 40 mA from the positive pin. The current that passes through the positive pin is $I = (V_{in} - 1.2 - V_{data}) / 680$. To reduce noise sensitivity, we recommend leaving a 20% margin for current variation (i.e., uses a digital input voltage that draws 4mA to 25mA).

Function	Pins	Min Voltage	Max Voltage	Min Current	Max Current	Min Pulse Width
Trigger_in	D, H	3.3 V	24 V	3 mA	40 mA	20 μ s

Encoder Input

Encoder input is provided by an external encoder and consists of three RS-485 signals. These signals are connected to Encoder_A, Encoder_B, and Encoder_Z.

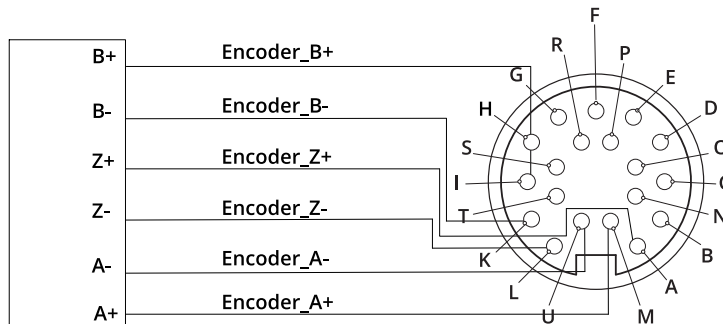

Function	Pins	Common Mode Voltage		Differential Threshold Voltage			Max Data Rate
		Min	Max	Min	Typ	Max	
Encoder_A	M, U	-7 V	12 V	-200 mV	-125 mV	-50 mV	1 MHz
Encoder_B	I, K	-7 V	12 V	-200 mV	-125 mV	-50 mV	1 MHz
Encoder_Z	A, L	-7 V	12 V	-200 mV	-125 mV	-50 mV	1 MHz

 Gocator only supports differential RS485 signalling. Both + and - signals must be connected.

 Encoders are normally specified in *pulses* per revolution, where each pulse is made up of the four quadrature *signals* (A+ / A- / B+ / B-). Because the sensor reads each of the four quadrature signals, you should choose an encoder accordingly, given the resolution required for your application.

Serial Output

Serial RS-485 output is connected to Serial_out as shown below.

Function	Pins
Serial_out	B, C

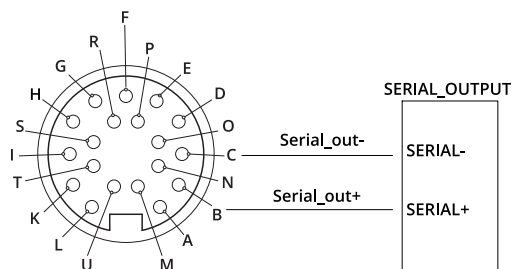

Selcom Serial Output

Serial RS-485 output is connected to Serial_out and Serial_out2 as shown below.

Function	Pins
Serial_out (data)	B, C
Serial_out2 (clock)	E, G

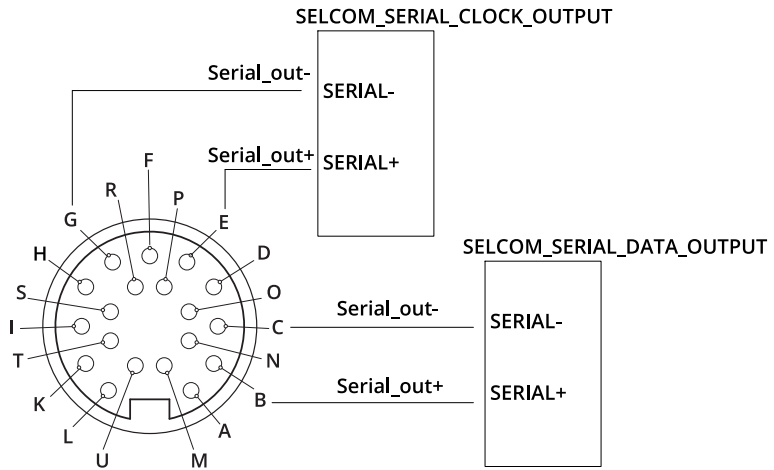

Analog Output

The Sensor I/O Connector defines one analog output interface: Analog_out.

 You do not need to supply an external power source.

Function	Pins	Current Range
Analog_out	P, F	4 – 20 mA

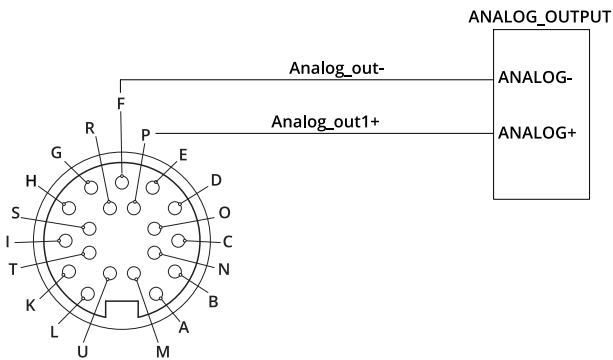

Current Mode

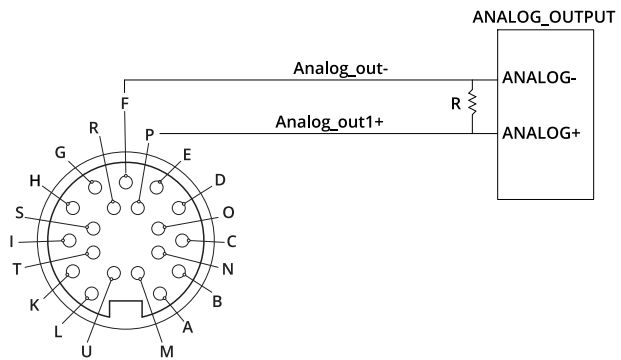

Voltage Mode

To configure for voltage output, connect a 500 Ohm $\frac{1}{4}$ Watt resistor between Analog_out+ and Analog_out- and measure the voltage across the resistor. To reduce the noise in the output, we recommend using an RC filter as shown below.

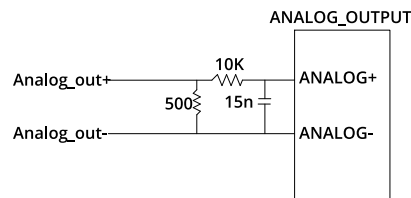

Master Network Controllers

The following sections provide the specifications of Master network controllers.

For information on maximum external input trigger rates, see *Maximum Input Trigger Rate* on page 98.

Master 100

The Master 100 accepts connections for power, safety, and encoder, and provides digital output.

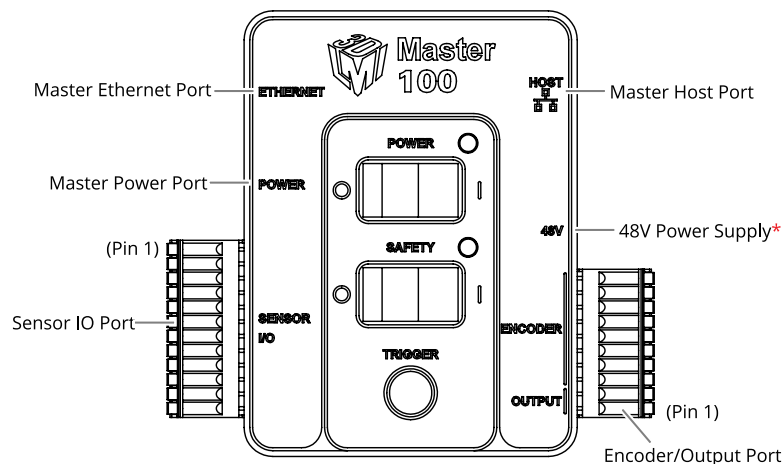

 *Contact LMI for information regarding this type of power supply.

Connect the Master Power port to the Gocator's Power/LAN connector using the Gocator Power/LAN to Master cordset. Connect power RJ45 end of the cordset to the Master Power port. The Ethernet RJ45 end of the cordset can be connected directly to the Ethernet switch, or connect to the Master Ethernet port. If the Master Ethernet port is used, connect the Master Host port to the Ethernet switch with a CAT5e Ethernet cable.

To use encoder and digital output, wire the Master's Gocator Sensor I/O port to the Gocator IO connector using the Gocator I/O cordset.

Sensor I/O Port Pins

I/O Pin	Master Pin	Conductor Color
Encoder_A+	1	White/Brown & Black
Encoder_A-	2	Brown/Black
Encoder_Z+	3	White/Green & Black
Encoder_Z-	4	Green/Black
Trigger_in+	5	Grey
Trigger_in-	6	Pink
Out_1-	7	Blue
Out_1+	8	Red

I/O Pin	Master Pin	Conductor Color
Encoder_B+	11	Black
Encoder_B-	12	Violet

The rest of the wires in the I/O cordset are not used.

Encoder/Output Port Pins

Function	Pin
Output_1+ (Digital Output 0)	1
Output_1- (Digital Output 0)	2
Encoder_Z+	3
Encoder_Z-	4
Encoder_A+	5
Encoder_A-	6
Encoder_B+	7
Encoder_B-	8
Encoder_GND	9
Encoder_5V	10

Master 100 Dimensions

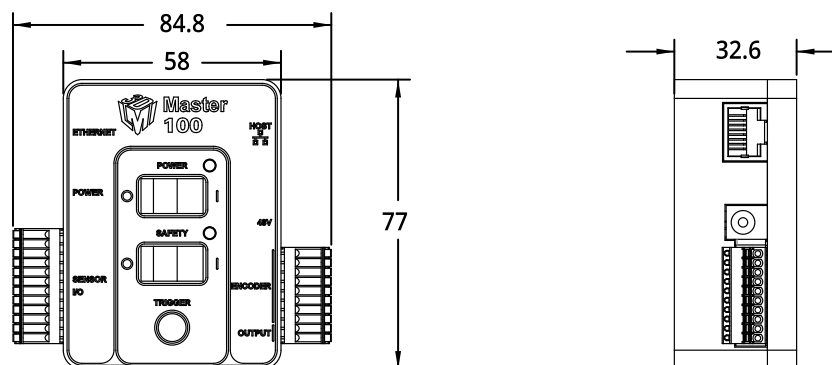

Master 400/800

Master network controllers provide sensor power and safety interlock, and broadcast system-wide synchronization information (i.e., time, encoder count, encoder index, and digital I/O states) to all devices on a sensor network.

The Phoenix connectors on Master 400/800/1200/2400 are not compatible with the connectors on Master 810/2410. For this reason, if you are switching models in your network, you must rewire the connections to the Master.

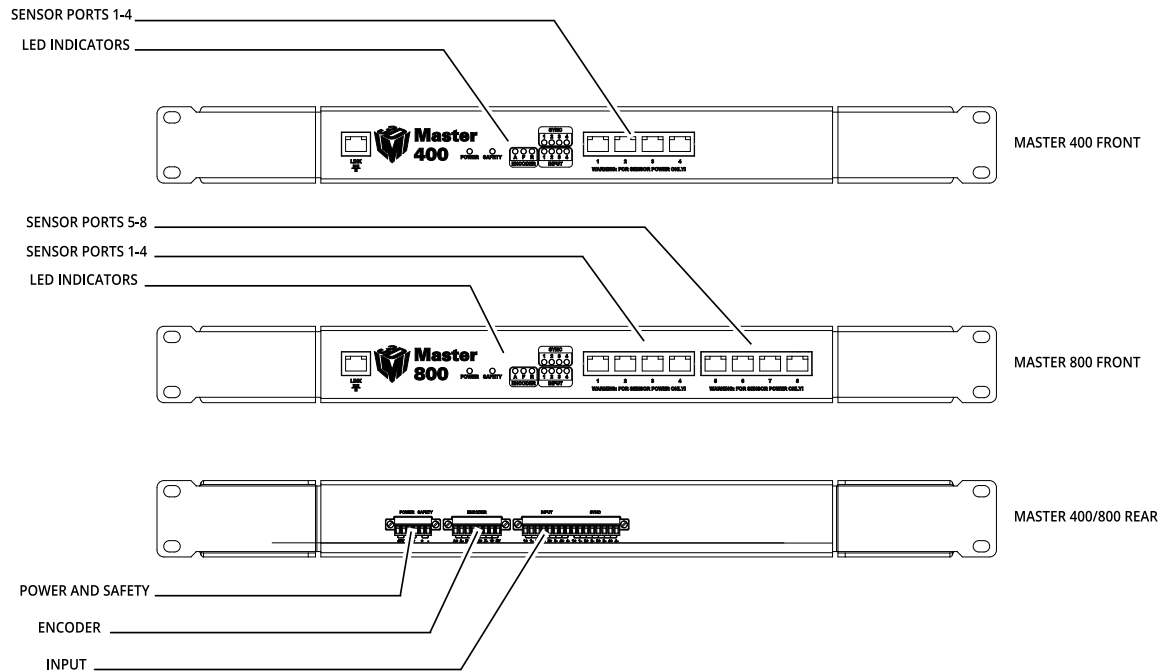

Power and Safety (6 pin connector)

Function	Pin
+48VDC	1
+48VDC	2
GND (24-48VDC)	3
GND (24-48VDC)	4
Safety Control+	5
Safety Control-	6

The power supply must be isolated from AC ground. This means that AC ground and DC ground are not connected.

The Safety Control requires a voltage differential of 24 VDC to 48 VDC across the pin to enable the laser.

Input (16 pin connector)

Function	Pin
Input 1	1
Input 1 GND	2
Reserved	3
Reserved	4
Reserved	5
Reserved	6
Reserved	7
Reserved	8
Reserved	9
Reserved	10
Reserved	11
Reserved	12
Reserved	13
Reserved	14
Reserved	15
Reserved	16



The Input connector does not need to be wired up for proper operation.

Encoder (8 pin connector)

Function	Pin
Encoder_A+	1
Encoder_A-	2
Encoder_B+	3
Encoder_B-	4
Encoder_Z+	5
Encoder_Z-	6
GND	7
+5VDC	8

Master 400/800 Electrical Specifications

Electrical Specifications

Specification	Value
Power Supply Voltage	+48 VDC
Power Supply Current (Max.)	10 A

Specification	Value
Power Draw (Min.)	5.76 W
Safety Input Voltage Range	+24 VDC to +48 VDC
Encoder Signal Voltage	Differential (5 VDC)
Digital Input Voltage Range	Logical LOW: 0 to +0.1 VDC Logical HIGH: +3.3 to +24 VDC



When using a Master hub, the chassis must be well grounded.



The power supply must be isolated from AC ground. This means that AC ground and DC ground are not connected.



The Power Draw specification is based on a Master with no sensors attached. Every sensor has its own power requirements that need to be considered when calculating total system power requirements..

Master 400/800 Dimensions

The dimensions of Master 400 and Master 800 are the same.

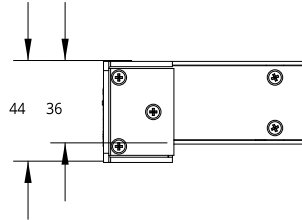
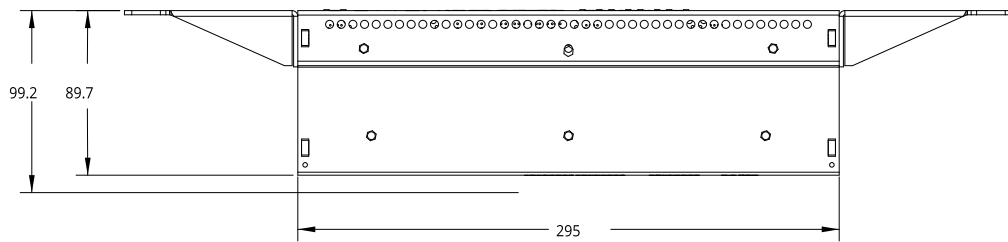
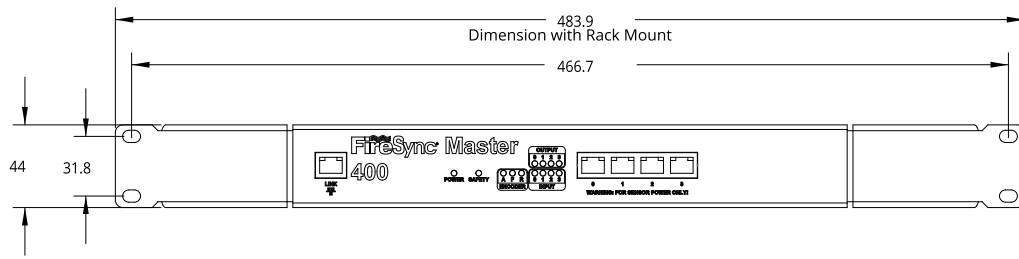

Master 810/2410

Master network controllers provide sensor power and safety interlock, and broadcast system-wide synchronization information (i.e., time, encoder count, encoder index, and digital I/O states) to all devices on a sensor network.

The following table summarizes Master 810 and 2410:

Master 810 and 2410	
Input Voltage (Power)	+24-48 VDC (2 Watts) ¹
Total Power	Master 810 / 2410 input power + (sensor input power x number of sensors)
Capacity	Master 810: up to 8 sensors Master 2410: up to 24 sensors
I/O	4 digital inputs ² Differential (5 VDC, 12 VDC) Single-ended active high/low (5 VDC, 12 VDC) Single-ended active high/low (5 VDC, 12 VDC) 10-pin Phoenix
Encoder	Differential (5 VDC, 12 VDC) Single-ended (5 VDC, 12 VDC) ³ 11-pin Phoenix connector
LED Indicators	Safety, power, encoder, input
Cable	Dual CAT5e cable for power / safety / synchronization / data
Weight (kg)	Master 810: 0.6 Master 2410: 0.9

Notes

1. Refer to sensor datasheets for additional power required by sensors.
2. Gocator only supports one digital input.
3. Supports open collector, pull-up resistor, line driver, push-pull, and TTL.

Master 810 and 2410 can be mounted to DIN rails using the provided adapters (for more information, see *Installing DIN Rail Clips: Master 810 or 2410* on page 39). The units are also provided with removable adapters for 1U rack mounting; the mounting holes for this option are compatible with older Master models (400/800/1200/2400).

 The Phoenix connectors on Master 400/800/1200/2400 are not compatible with the connectors on Master 810/2410. For this reason, if you are switching models in your network, you must rewire the connections to the Master.

Master 2410 can currently be used with encoders with a maximum quadrature frequency of 300 kHz.

Master 810 can be configured to work with a maximum encoder quadrature frequency of 6.5 MHz. For more information, see *Configuring Master 810* on page 40.

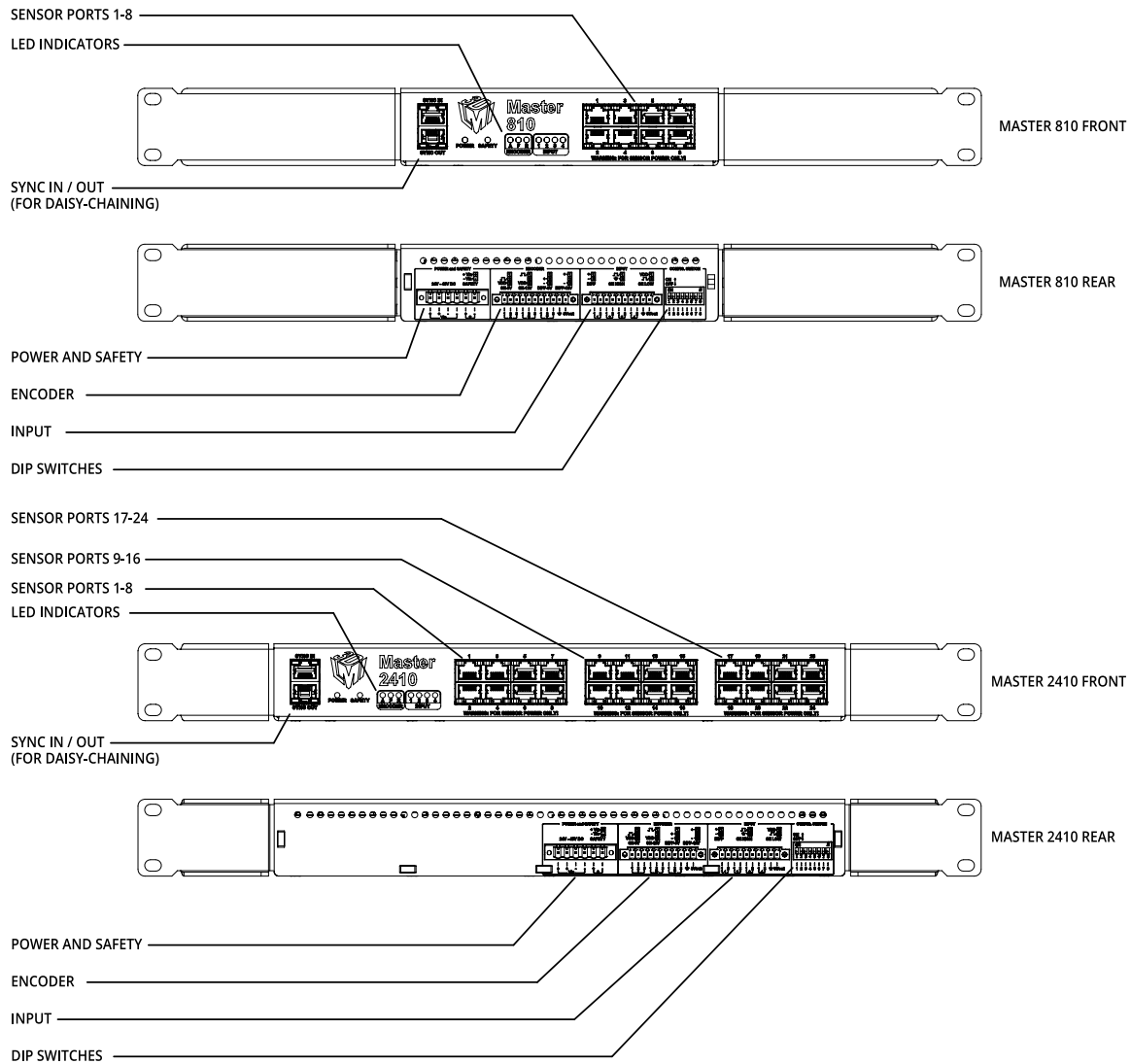

Power and Safety (6 pin connector)

Function	Pin
Power In+	1
Power In+	2
Power In-	3
Power In-	4
Safety Control+	5
Safety Control-	6

 The power supply must be isolated from AC ground. This means that AC ground and DC ground are not connected.

 The Safety Control requires a voltage differential of 24 VDC to 48 VDC across the pin to enable the laser.

 On earlier revisions of Master 810 and Master 2410, the inputs are labeled 0-3.

Input (10 pin connector)

Function	Pin
Input 1 Pin 1	1
Input 1 Pin 2	2
Reserved	3
Reserved	4
Reserved	5
Reserved	6
Reserved	7
Reserved	8
GND (output for powering other devices)	9
+5VDC (output for powering other devices)	10

 The Input connector does not need to be wired up for proper operation.

 For Input connection wiring options, see *Input* on page 557.

Encoder (11 pin connector)

Function	Pin
Encoder_A_Pin_1	1
Encoder_A_Pin_2	2
Encoder_A_Pin_3	3
Encoder_B_Pin_1	4
Encoder_B_Pin_2	5
Encoder_B_Pin_3	6
Encoder_Z_Pin_1	7
Encoder_Z_Pin_2	8
Encoder_Z_Pin_3	9
GND (output for powering external devices)	10
+5VDC (output for powering external devices)	11

 For Encoder connection wiring options, see *Encoder* on page 556.

Electrical Specifications

Electrical Specifications

Specification	Value
Power Supply Voltage	+24 VDC to +48 VDC
Power Supply Current (Max.)*	Master 810: 9 A Master 2410: 25 A * Fully loaded with 1 A per sensor port.
Power Draw (Min.)	Master 810: 1.7 W Master 2410: 4.8 W
Safety Input Voltage Range	+24 VDC to +48 VDC
Encoder Signal Voltage	Differential (5 VDC, 12 VDC) Single-Ended (5 VDC, 12 VDC) For more information, see <i>Encoder</i> on the next page.
Digital Input Voltage Range	Single-Ended Active LOW: 0 to +0.8 VDC Single-Ended Active HIGH: +3.3 to +24 VDC Differential LOW: 0.8 to -24 VDC Differential HIGH: +3.3 to +24 VDC For more information, see <i>Input</i> on page 557.



If the input voltage is above 24 V, use an external resistor, using the following formula:

$$R = [(V_{in} - 1.2V) / 10mA] - 680$$



When using a Master hub, the chassis must be well grounded.



The power supply must be isolated from AC ground. This means that AC ground and DC ground are not connected.



24 VDC power supply is only supported if all connected sensors support an input voltage of 24 VDC.



The Power Draw specification is based on a Master with no sensors attached. Every sensor has its own power requirements that need to be considered when calculating total system power requirements..

Encoder

Master 810 and 2410 support the following types of encoder signals: Single-Ended (5 VDC, 12 VDC) and Differential (5 VDC, 12 VDC).

For 5 VDC operation, pins 2 and 3 of each channel are used.

For 12 VDC operation, pins 1 and 3 of each channel are used.

 The 5-volt encoder input supports up to 12 volts for compatibility with earlier Master network controllers. However, we strongly recommend connecting 12-volt output encoders to the appropriate 12-volt input to attain maximum tolerance.

To determine how to wire a Master to an encoder, see the illustrations below.

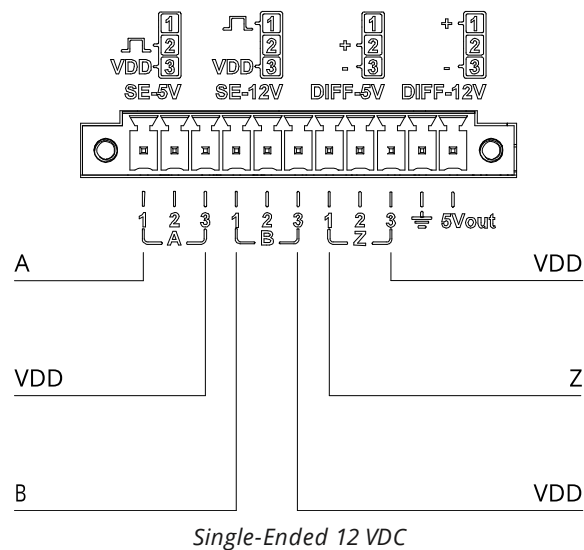
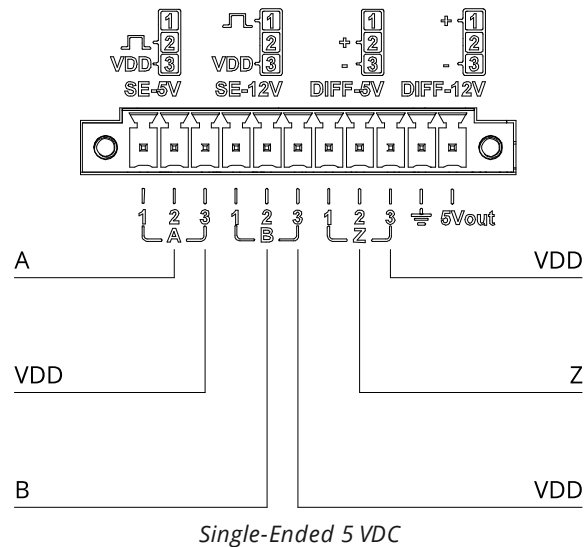

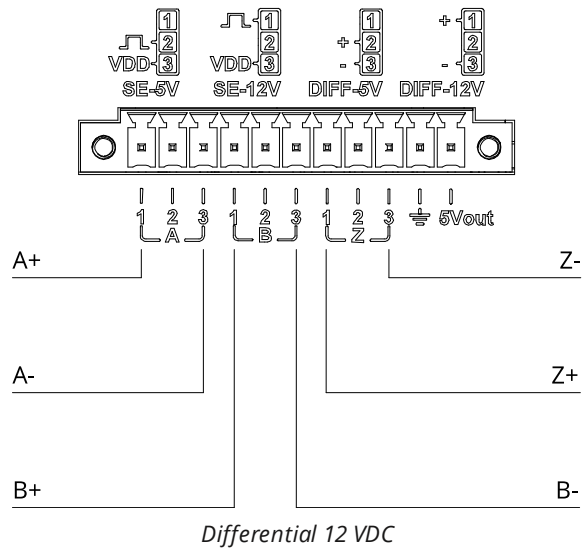
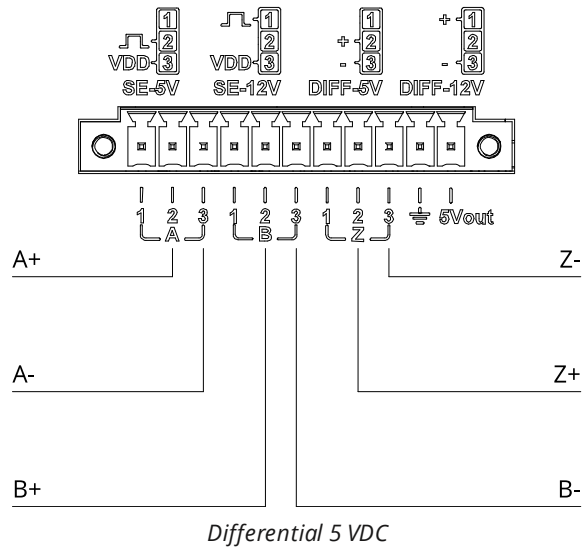

Input

Master 810 and 2410 support the following types of input: Differential, Single-Ended High, and Single-Ended Low.



Currently, Gocator only supports Input 0.

For digital input voltage ranges, see the table below.

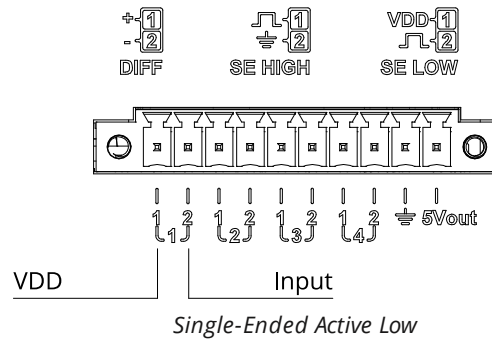
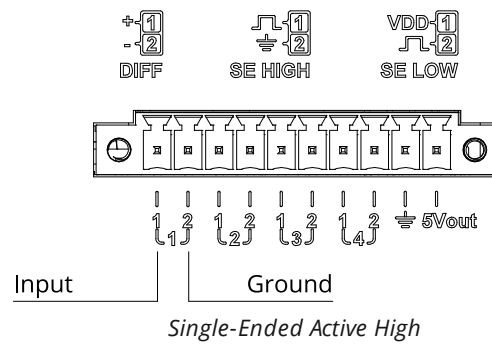
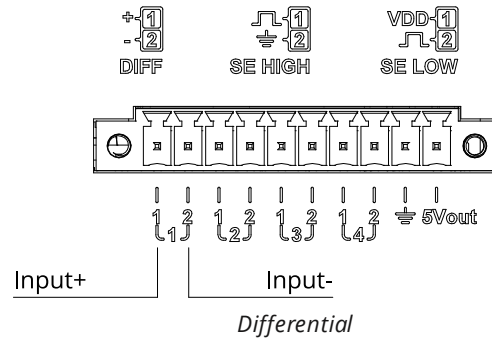

Digital Input Voltage Ranges

	Input Status	Min (VDC)	Max (VDC)
Single-ended Active High	Off	0	+0.8
	On	+3.3	+24
Single-ended Active Low	Off	(V _{DD} - 0.8)	V _{DD}
	On	0	(V _{DD} - 3.3)
Differential	Off	-24	+0.8
	On	+3.3	+24

Master 810 Dimensions

With 1U rack mount brackets:

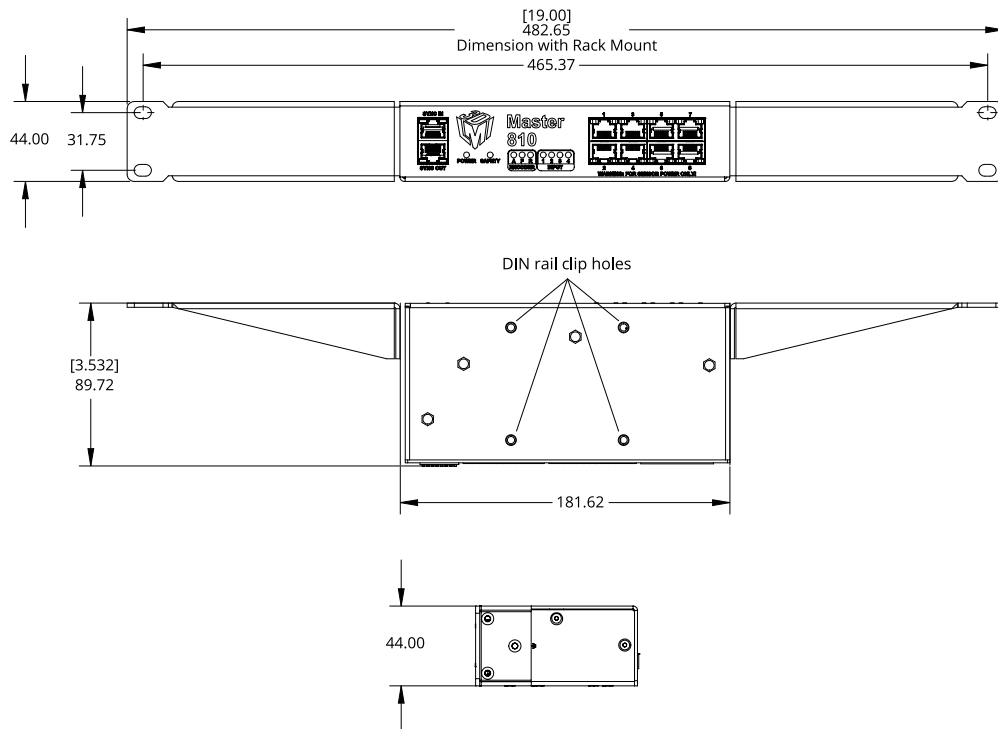

With DIN rail mount clips:

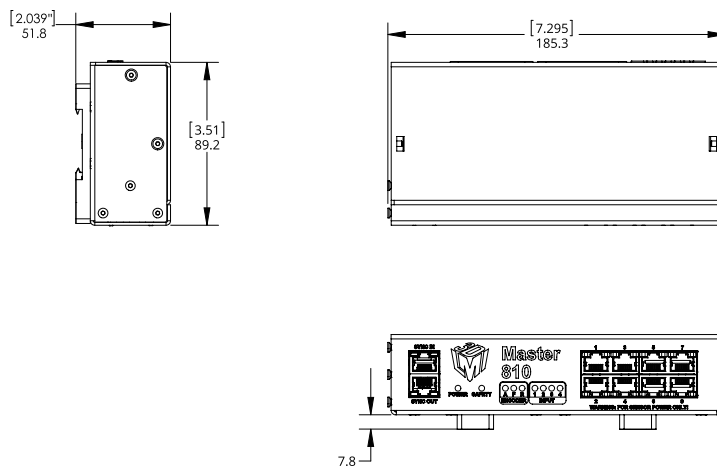

Older revisions of Master 810 and 2410 network controllers use a different configuration for the DIN rail clip holes.

For information on installing DIN rail clips, see *Installing DIN Rail Clips: Master 810 or 2410* on page 39.

The CAD model of the DIN rail clip is available at <https://www.winford.com/products/cad/dinm12-rc.igs>.

Master 2410 Dimensions

With 1U rack mount brackets:

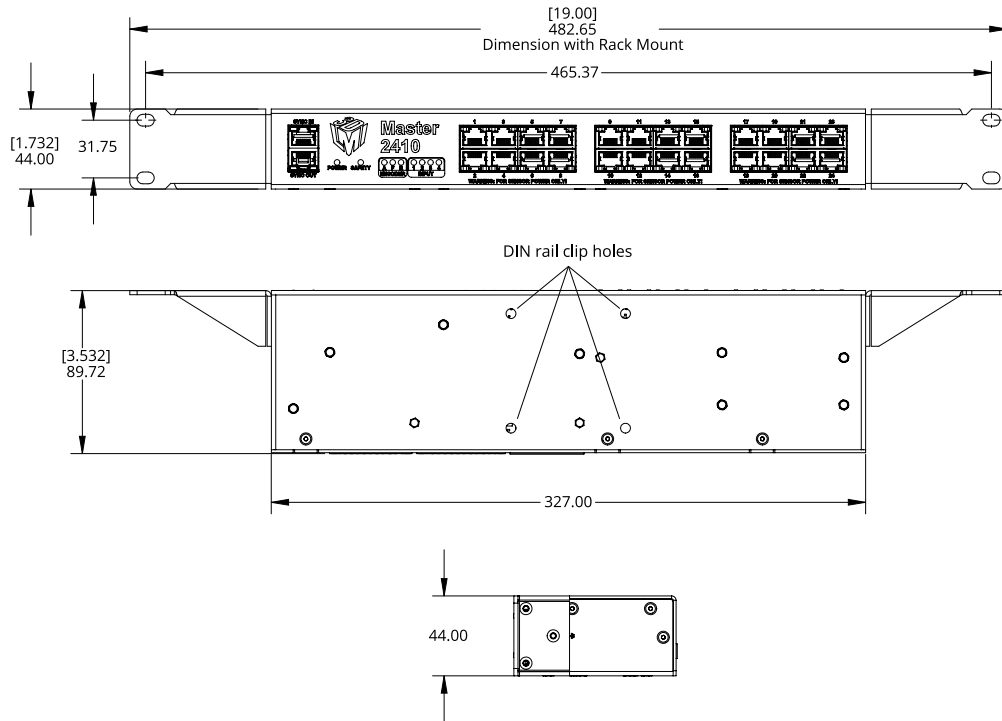

With DIN rail mount clips:

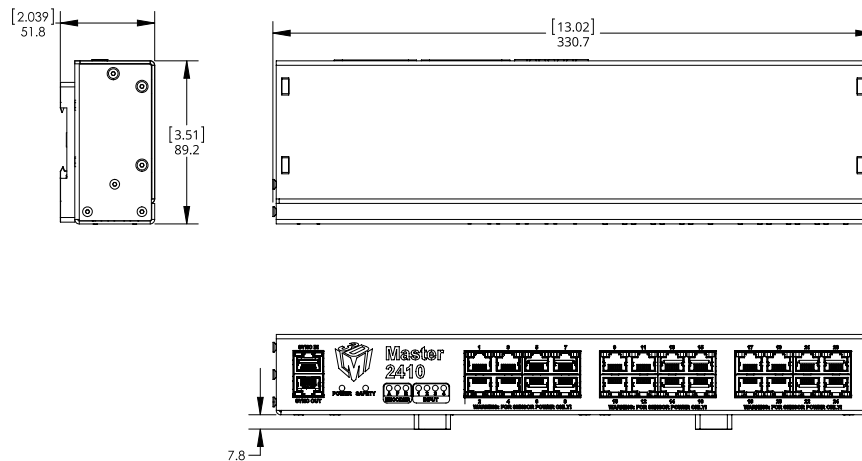

Older revisions of Master 810 and 2410 network controllers use a different configuration for the DIN rail clip holes.

For information on installing DIN rail clips, see *Installing DIN Rail Clips: Master 810 or 2410* on page 39.

The CAD model of the DIN rail clip is available at <https://www.winford.com/products/cad/dinm12-rc.igs>.

Master 1200/2400

Master network controllers provide sensor power and safety interlock, and broadcast system-wide synchronization information (i.e., time, encoder count, encoder index, and digital I/O states) to all devices on a sensor network.

The Phoenix connectors on Master 400/800/1200/2400 are not compatible with the connectors on Master 810/2410. For this reason, if you are switching models in your network, you must rewire the connections to the Master.

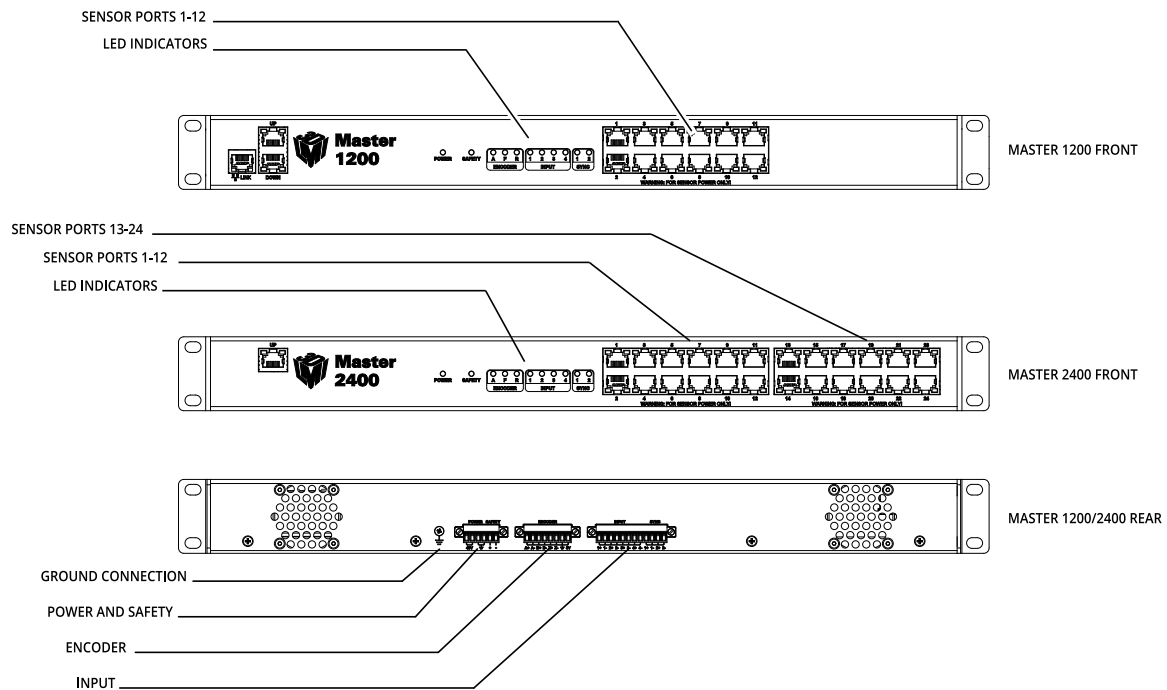

Power and Safety (6 pin connector)

Function	Pin
+48VDC	1
+48VDC	2
GND (24-48VDC)	3
GND (24-48VDC)	4
Safety Control+	5
Safety Control-	6

The power supply must be isolated from AC ground. This means that AC ground and DC ground are not connected.

The Safety Control requires a voltage differential of 24 VDC to 48 VDC across the pin to enable the laser.

Input (12 pin connector)

Function	Pin
Input 1	1
Input 1 GND	2
Reserved	3
Reserved	4
Reserved	5
Reserved	6
Reserved	7
Reserved	8
Reserved	9
Reserved	10
Reserved	11
Reserved	12



The Input connector does not need to be wired up for proper operation.

Encoder (8 pin connector)

Function	Pin
Encoder_A+	1
Encoder_A-	2
Encoder_B+	3
Encoder_B-	4
Encoder_Z+	5
Encoder_Z-	6
GND	7
+5VDC	8

Master 1200/2400 Electrical Specifications

Electrical Specifications

Specification	Value
Power Supply Voltage	+48 VDC
Power Supply Current (Max.)	10 A
Power Draw (Min.)	5.76 W
Safety Input Voltage Range	+24 VDC to +48 VDC
Encoder Signal Voltage	Differential (5 VDC)
Digital Input Voltage Range	Logical LOW: 0 to +0.1 VDC Logical HIGH: +3.5 to +6.5 VDC



When using a Master hub, the chassis must be well grounded.



The power supply must be isolated from AC ground. This means that AC ground and DC ground are not connected.



The Power Draw specification is based on a Master with no sensors attached. Every sensor has its own power requirements that need to be considered when calculating total system power requirements..

Master 1200/2400 Dimensions

The dimensions of Master 1200 and Master 2400 are the same.

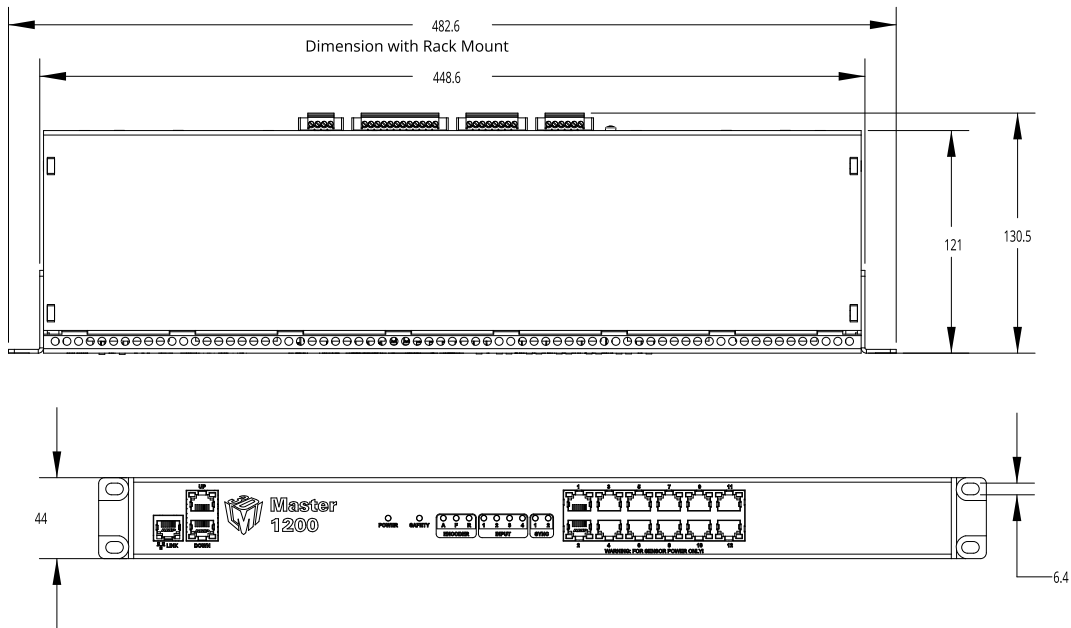

Accessories

Masters

Description	Part Number
Master 100 - for single sensor (development only)	30705
Master 810 - for networking up to 8 sensors	301114
Master 2410 - for networking up to 24 sensors	301115

Cordsets

Description	Part Number
1.2m I/O cordset, open wire end	30864-1.2m
2m I/O cordset, open wire end	30864-2m
5m I/O cordset, open wire end	30864-5m
10m I/O cordset, open wire end	30864-10m
15m I/O cordset, open wire end	30864-15m
20m I/O cordset, open wire end	30864-20m
25m I/O cordset, open wire end	30864-25m
2m Power and Ethernet cordset, 1x open wire end, 1x RJ45 end	30861-2m
5m Power and Ethernet cordset, 1x open wire end, 1x RJ45 end	30861-5m
10m Power and Ethernet cordset, 1x open wire end, 1x RJ45 end	30861-10m
15m Power and Ethernet cordset, 1x open wire end, 1x RJ45 end	30861-15m
20m Power and Ethernet cordset, 1x open wire end, 1x RJ45 end	30861-20m
25m Power and Ethernet cordset, 1x open wire end, 1x RJ45 end	30861-25m
1.2m Power and Ethernet to Master cordset, 2x RJ45 ends	30858-1.2m
2m Power and Ethernet to Master cordset, 2x RJ45 ends	30858-2m
5m Power and Ethernet to Master cordset, 2x RJ45 ends	30858-5m
10m Power and Ethernet to Master cordset, 2x RJ45 ends	30858-10m
15m Power and Ethernet to Master cordset, 2x RJ45 ends	30858-15m
20m Power and Ethernet to Master cordset, 2x RJ45 ends	30858-20m
25m Power and Ethernet to Master cordset, 2x RJ45 ends	30858-25m

Cordsets - 90-degree

Description	Part Number
2m I/O cordset, 90-deg, open wire end	30883-2m
5m I/O cordset, 90-deg, open wire end	30883-5m

Description	Part Number
10m I/O cordset, 90-deg, open wire end	30883-10m
15m I/O cordset, 90-deg, open wire end	30883-15m
20m I/O cordset, 90-deg, open wire end	30883-20m
25m I/O cordset, 90-deg, open wire end	30883-25m
2m Power and Ethernet cordset, 90-deg, 1x open wire end, 1x RJ45 end	30880-2m
5m Power and Ethernet cordset, 90-deg, 1x open wire end, 1x RJ45 end	30880-5m
10m Power and Ethernet cordset, 90-deg, 1x open wire end, 1x RJ45 end	30880-10m
15m Power and Ethernet cordset, 90-deg, 1x open wire end, 1x RJ45 end	30880-15m
20m Power and Ethernet cordset, 90-deg, 1x open wire end, 1x RJ45 end	30880-20m
25m Power and Ethernet cordset, 90-deg, 1x open wire end, 1x RJ45 end	30880-25m
2m Power and Ethernet to Master cordset, 90-deg, 2x RJ45 ends	30877-2m
5m Power and Ethernet to Master cordset, 90-deg, 2x RJ45 ends	30877-5m
10m Power and Ethernet to Master cordset, 90-deg, 2x RJ45 ends	30877-10m
15m Power and Ethernet to Master cordset, 90-deg, 2x RJ45 ends	30877-15m
20m Power and Ethernet to Master cordset, 90-deg, 2x RJ45 ends	30877-20m
25m Power and Ethernet to Master cordset, 90-deg, 2x RJ45 ends	30877-25m

90-degree cordsets are not stocked. Lead times for delivery may be longer.

Custom cordset lengths and connector orientations are available upon request. Prices depend on length and orientation requested. For standard cordsets, the maximum cable length is 60 m.

High Flex Cordsets

Description	Part Number
2m I/O cordset, open wire end	301175-2m
5m I/O cordset, open wire end	301175-5m
10m I/O cordset, open wire end	301175-10m
2m Power and Ethernet cordset, 1x open wire end, 1x RJ45 end	301176-2m
5m Power and Ethernet cordset, 1x open wire end, 1x RJ45 end	301176-5m
10m Power and Ethernet cordset, 1x open wire end, 1x RJ45 end	301176-10m
2m Power and Ethernet to Master cordset, 2x RJ45 ends	301165-2m
5m Power and Ethernet to Master cordset, 2x RJ45 ends	301165-5m
10m Power and Ethernet to Master cordset, 2x RJ45 ends	301165-10m
Description	Part Number
2m I/O cordset, 90-deg, open wire end	301172-2m
5m I/O cordset, 90-deg, open wire end	301172-5m
10m I/O cordset, 90-deg, open wire end	301172-10m
2m Power and Ethernet cordset, 90-deg, 1x open wire end, 1x RJ45 end	301171-2m

Description	Part Number
5m Power and Ethernet cordset, 90-deg, 1x open wire end, 1x RJ45 end	301171-5m
10m Power and Ethernet cordset, 90-deg, 1x open wire end, 1x RJ45 end	301171-10m
2m Power and Ethernet to Master cordset, 90-deg, 2x RJ45 ends	301173-2m
5m Power and Ethernet to Master cordset, 90-deg, 2x RJ45 ends	301173-5m
10m Power and Ethernet to Master cordset, 90-deg, 2x RJ45 ends	301173-10m

Return Policy

Return Policy

Before returning the product for repair (warranty or non-warranty) a Return Material Authorization (RMA) number must be obtained from LMI. Please call LMI to obtain this RMA number.

Carefully package the sensor in its original shipping materials (or equivalent) and ship the sensor prepaid to your designated LMI location. Please ensure that the RMA number is clearly written on the outside of the package. Inside the return shipment, include the address you wish the shipment returned to, the name, email and telephone number of a technical contact (should we need to discuss this repair), and details of the nature of the malfunction. For non-warranty repairs, a purchase order for the repair charges must accompany the returning sensor.

LMI Technologies Inc. is not responsible for damages to a sensor that are the result of improper packaging or damage during transit by the courier.

Software Licenses

Pico-C

Website:

<http://code.google.com/p/picoc/>

License:

picoc is published under the "New BSD License".

<http://www.opensource.org/licenses/bsd-license.php>

Copyright (c) 2009-2011, Zik Saleeba

All rights reserved.

Redistribution and use in source and binary forms, with or without modification, are permitted provided that the following conditions are met:

- * Redistributions of source code must retain the above copyright notice, this list of conditions and the following disclaimer.
- * Redistributions in binary form must reproduce the above copyright notice, this list of conditions and the following disclaimer in the documentation and/or other materials provided with the distribution.
- * Neither the name of the Zik Saleeba nor the names of its contributors may be used to endorse or promote products derived from this software without specific prior written permission.

THIS SOFTWARE IS PROVIDED BY THE COPYRIGHT HOLDERS AND CONTRIBUTORS "AS IS" AND ANY EXPRESS OR IMPLIED WARRANTIES, INCLUDING, BUT NOT LIMITED TO, THE IMPLIED WARRANTIES OF MERCHANTABILITY AND FITNESS FOR A PARTICULAR PURPOSE ARE DISCLAIMED. IN NO EVENT SHALL THE COPYRIGHT OWNER OR CONTRIBUTORS BE LIABLE FOR ANY DIRECT, INDIRECT, INCIDENTAL, SPECIAL, EXEMPLARY, OR CONSEQUENTIAL DAMAGES (INCLUDING, BUT NOT LIMITED TO, PROCUREMENT OF SUBSTITUTE GOODS OR SERVICES; LOSS OF USE, DATA, OR PROFITS; OR BUSINESS INTERRUPTION) HOWEVER CAUSED AND ON ANY THEORY OF LIABILITY, WHETHER IN CONTRACT, STRICT LIABILITY, OR TORT (INCLUDING NEGLIGENCE OR OTHERWISE) ARISING IN ANY WAY OUT OF THE USE OF THIS SOFTWARE, EVEN IF ADVISED OF THE POSSIBILITY OF SUCH DAMAGE.

BlowFish

Website:

<http://www.chiark.greenend.org.uk/~sgtatham/putty/licence.html>

License:

PuTTY is copyright 1997-2011 Simon Tatham.

Portions copyright Robert de Bath, Joris van Rantwijk, Delian Delchev, Andreas Schultz, Jeroen Massar, Wez Furlong, Nicolas Barry, Justin Bradford, Ben Harris, Malcolm Smith, Ahmad Khalifa, Markus Kuhn, Colin Watson, and CORE SDI S.A.

Permission is hereby granted, free of charge, to any person obtaining a copy of this software and associated documentation files (the "Software"), to deal in the Software without restriction, including without limitation the rights to use, copy, modify, merge, publish, distribute, sublicense, and/or sell copies of the Software, and to permit persons to whom the Software is furnished to do so, subject to the following conditions:

The above copyright notice and this permission notice shall be included in all copies or substantial portions of the Software.

THE SOFTWARE IS PROVIDED "AS IS", WITHOUT WARRANTY OF ANY KIND, EXPRESS OR IMPLIED, INCLUDING BUT NOT LIMITED TO THE WARRANTIES OF MERCHANTABILITY, FITNESS FOR A PARTICULAR PURPOSE AND NONINFRINGEMENT. IN NO EVENT SHALL SIMON TATHAM BE LIABLE FOR ANY CLAIM, DAMAGES OR OTHER LIABILITY, WHETHER IN AN ACTION OF CONTRACT, TORT OR OTHERWISE, ARISING FROM, OUT OF OR IN CONNECTION WITH THE SOFTWARE OR THE USE OR OTHER DEALINGS IN THE SOFTWARE.

CodeMirror

Website:

<http://codemirror.net>

License:

Copyright (C) 2011 by Marijn Haverbeke <marijnh@gmail.com>

Permission is hereby granted, free of charge, to any person obtaining a copy of this software and associated documentation files (the "Software"), to deal in the Software without restriction, including without limitation the rights to use, copy, modify, merge, publish, distribute, sublicense, and/or sell copies of the Software, and to permit persons to whom the Software is furnished to do so, subject to the following conditions:

The above copyright notice and this permission notice shall be included in all copies or substantial portions of the Software.

THE SOFTWARE IS PROVIDED "AS IS", WITHOUT WARRANTY OF ANY KIND, EXPRESS OR IMPLIED, INCLUDING BUT NOT LIMITED TO THE WARRANTIES OF MERCHANTABILITY, FITNESS FOR A PARTICULAR PURPOSE AND NONINFRINGEMENT. IN NO EVENT SHALL THE AUTHORS OR COPYRIGHT HOLDERS BE LIABLE FOR ANY CLAIM, DAMAGES OR OTHER LIABILITY, WHETHER IN AN ACTION OF CONTRACT, TORT OR OTHERWISE, ARISING FROM, OUT OF OR IN CONNECTION WITH THE SOFTWARE OR THE USE OR OTHER DEALINGS IN THE SOFTWARE.

jQuery

Website:

<http://jquery.com/>

License:

Copyright (c) 2011 John Resig, <http://jquery.com/>

Permission is hereby granted, free of charge, to any person obtaining a copy of this software and associated documentation files (the "Software"), to deal in the Software without restriction, including without limitation the rights to use, copy, modify, merge, publish, distribute, sublicense, and/or sell copies of the Software, and to permit persons to whom the Software is furnished to do so, subject to the following conditions:

The above copyright notice and this permission notice shall be included in all copies or substantial portions of the Software.

THE SOFTWARE IS PROVIDED "AS IS", WITHOUT WARRANTY OF ANY KIND, EXPRESS OR IMPLIED, INCLUDING BUT NOT LIMITED TO THE WARRANTIES OF MERCHANTABILITY, FITNESS FOR A PARTICULAR PURPOSE AND NONINFRINGEMENT. IN NO EVENT SHALL THE AUTHORS OR COPYRIGHT HOLDERS BE LIABLE FOR ANY CLAIM, DAMAGES OR OTHER LIABILITY, WHETHER IN AN ACTION OF CONTRACT, TORT OR OTHERWISE, ARISING FROM, OUT OF OR IN CONNECTION WITH THE SOFTWARE OR THE USE OR OTHER DEALINGS IN THE SOFTWARE.

Three.js

The MIT License

Copyright (c) 2010-2013 three.js authors

Permission is hereby granted, free of charge, to any person obtaining a copy of this software and associated documentation files (the "Software"), to deal in the Software without restriction, including without limitation the rights to use, copy, modify, merge, publish, distribute, sublicense, and/or sell

copies of the Software, and to permit persons to whom the Software is furnished to do so, subject to the following conditions:

The above copyright notice and this permission notice shall be included in all copies or substantial portions of the Software.

THE SOFTWARE IS PROVIDED "AS IS", WITHOUT WARRANTY OF ANY KIND, EXPRESS OR IMPLIED, INCLUDING BUT NOT LIMITED TO THE WARRANTIES OF MERCHANTABILITY, FITNESS FOR A PARTICULAR PURPOSE AND NONINFRINGEMENT. IN NO EVENT SHALL THE AUTHORS OR COPYRIGHT HOLDERS BE LIABLE FOR ANY CLAIM, DAMAGES OR OTHER LIABILITY, WHETHER IN AN ACTION OF CONTRACT, TORT OR OTHERWISE, ARISING FROM, OUT OF OR IN CONNECTION WITH THE SOFTWARE OR THE USE OR OTHER DEALINGS IN THE SOFTWARE.

jQuery.CopyEvents

Website:

<http://brandonaron.net>

License:

Copyright (c) 2006 Brandon Aaron

Licensed under the MIT License (<http://www.opensource.org/licenses/mit-license.php>)

jQuery.history

License:

jQuery history plugin

Copyright (c) 2006 Taku Sano (Mikage Sawatari)

Licensed under the MIT License (<http://www.opensource.org/licenses/mit-license.php>)

Modified by Lincoln Cooper to add Safari support and only call the callback once during initialization for msie when no initial hash supplied. API rewrite by Lauris Bukis-Haberkorns

jQuery.mouseWheel

Website:

<http://brandonaron.net>

License:

Copyright (c) 2010 Brandon Aaron

Licensed under the MIT License (<http://www.opensource.org/licenses/mit-license.php>)

jQuery.scaling

Website:

<http://eric.garside.name>

License:

Scaling 1.0 - Scale any page element

Copyright (c) 2009 Eric Garside

Licensed under the MIT License (<http://www.opensource.org/licenses/mit-license.php>)

jQuery.scrollFollow

Website:

<http://kitchen.net-perspective.com/>

License:

Copyright (c) 2008 Net Perspective

Licensed under the MIT License (<http://www.opensource.org/licenses/mit-license.php>)

EtherNet/IP Communication Stack

Website:

sourceforge.net/projects/opener

License:

SOFTWARE DISTRIBUTION LICENSE FOR THE
ETHERNET/IP(TM) COMMUNICATION STACK (ADAPTED BSD STYLE LICENSE)

Copyright (c) 2009, Rockwell Automation, Inc. ALL RIGHTS RESERVED.

EtherNet/IP is a trademark of ODVA, Inc.

Support

For help with a component or product, please submit an online support ticket using LMI's [Help Desk](http://support.lmi3d.com/newticket.php) at <http://support.lmi3d.com/newticket.php>.

If you are unable to use the Help Desk or prefer to contact LMI by phone or email, use the contact information below.



Response times for phone or email support requests are longer than requests submitted through the Help Desk.

North America

Phone	+1 604 636 1011
Fax	+1 604 516 8368
Email	support@lmi3d.com

Europe

Phone	+31 45 850 7000
Fax	+31 45 574 2500
Email	support@lmi3d.com

For more information on safety and laser classifications, please contact:

*U.S. Food and Drug Administration
Center for Devices and Radiological Health
WO66-G609
10903 New Hampshire Avenue
Silver Spring MD 20993-0002
USA*

Contact

Americas	EMEAR	ASIA PACIFIC
LMI Technologies (Head Office) Burnaby, Canada +1 604 636 1011	LMI Technologies GmbH Berlin, Germany +49 (0)3328 9360 0	LMI (Shanghai) Trading Co., Ltd. Shanghai, China +86 21 5441 0711

LMI Technologies has sales offices and distributors worldwide. All contact information is listed at lmi3d.com/contact/locations.